

# FACULTY OF ENGINEERING AND TECHNOLOGY

LADOKE AKINTOLA UNIVERSITY OF TECHNOLOGY, OGBOMOSO

# 4<sup>th</sup>

INTERNATIONAL  
CONFERENCE ON  
ENGINEERING AND  
TECHNOLOGY  
RESEARCH

## CONFERENCE PROCEEDINGS

t h e m e :

## Technology and Entrepreneurship as tools for

# ECONOMIC Advancement

FEB.  
23-25  
2016

@

CHIEF TUNDE AFOLABI LECTURE THEATRE /FET CAD CENTER  
Ladoke Akintola University of Technology  
(LAUTECH), Ogbomoso.

**Proceedings of the Fourth International Conference on  
Engineering and Technology Research**

**held from 23rd to 25th February, 2016  
@ Ladoke Akintola University of Technology, Ogbomosho**

**Editor-in-Chief**  
Dr. Mrs A.A. Adigun

**Keynote Speakers**

Prof. Olumide Longe (Adeleke University, Nigeria)

Prof. Josiah Adeyemo (Durban University of Technology, RSA)

Prof. Adekunle Okunoye (William College Business, Xavier  
University, U.S.A.)

Dr. Bamidele Makanjuola (Chairman, Vitafoam Nig. Ltd)

**ISBN: 978-2902-58-6 (Volume 4)**



## A GSM-BASED REMOTE CONTROLLED POULTRY FEED DISPENSING SYSTEM USING DTMF

<sup>1</sup>Ahmed A., <sup>2</sup>Olaniyi O. M., <sup>3</sup>Dogo E.M., <sup>4</sup>James E.

<sup>1,2,3,4</sup>Department of Computer Engineering, Federal University of Technology Minna, Nigeria  
<sup>1</sup>[aliyu.ahmed@futminna.edu.ng](mailto:aliyu.ahmed@futminna.edu.ng), <sup>2</sup>[mikail.olaniyi@futminna.edu.ng](mailto:mikail.olaniyi@futminna.edu.ng), <sup>3</sup>[eustace.dogo@futminna.edu.ng](mailto:eustace.dogo@futminna.edu.ng), and  
<sup>4</sup>[james.emmanuel@st.futminna.edu.ng](mailto:james.emmanuel@st.futminna.edu.ng)

Corresponding author: [aliyu.ahmed@futminna.edu.ng](mailto:aliyu.ahmed@futminna.edu.ng)

### Abstract

Poultry rearing for small scale and commercial farmers has made large contribution in food production. With the recent decline in contribution of livestock subsectors to the national economy, there is a need to devise a means of making poultry farming convenient, attractive and maximize yield. Automated Feeding is considered very important in poultry production; however, many farmers in the tropical regions practice subsistence farming and mostly employ manual poultry feeding. This paper presents the development of a GSM-based remote control poultry feed dispensing system via Dual Tone Multi-frequency (DTMF) for intermittent control of poultry feed dispensing. Proper knowledge in this area by farmer will help in running effective production and increase yield in meat and egg to maximize profit. The system is multi state fully input dependent system whose change of state can be controlled by a remote control. The developed mechatronic system reduces manpower, saves time and operates efficiently with minimal human involvement in poultry feeding. The system demonstrated practical effort regarding the improvement in performance of existing solid feed dispensing for high yield with minimal human intervention.

**KEYWORDS:** Poultry, solid feed, GSM, DTMF, Mechatronics.

### 1. Introduction

Poultry rearing for small scale or commercial farmers has made large Contribution in food, energy and fertilizer industries. Poultry involves the rearing of collective group of birds such as turkey, fowl, ducks, geese and domestic chicken (Olaniyi *et al.*, 2013). Poultry rearing can be practiced in large or small scale method whose primary purpose is for meat and egg production, in addition, their feathers can be used for pillow production (Oluayemi & Robert, 2002).

Feeding is considered very important in poultry production (Arulogun *et al.*, 2010). Many of the farmers

in the tropics still use manual method of feeding because of lack of knowledge coupled with the fact that they practice subsistence level. “In Nigeria the major source of protein is the livestock industry, and contributions of livestock subsectors to Gross domestic product GDP have decreased from 5.61% in 1960 to about 2.64% in 2010” (Romolaran *et al.*, 2013). Acquisition of adequate knowledge in this area by the practicing farmers will help in running effective production system and increase yield in meat and egg that will maximize profit. More so, it is on record that feed is responsible for 75% of the cost of production (Olaniyi *et al.* 2013).

In the developing world, poultry makes a significant contribution to the upkeep of the household, for example, it provides high quality food and energy along with fertilizer. Unfortunately, too much individual involvement in small scale poultry farming system is really a challenge in poultry management. Manual method of feeding remains a major challenge in Nigeria among small scale farmers. It results in inefficient use of labour and fatigue of the personnel, thus making the cost of production in poultry farming unnecessarily high resulting in high capital layout and low profit yielding. Moreover, easy spread of diseases in subsistence poultry farming is also linked to manual system of feeding. The level of productivity often falls below the potential attainable level. Losses suffered due to wastages are often higher. These always discourage future poultry farmers from venturing in to the business.

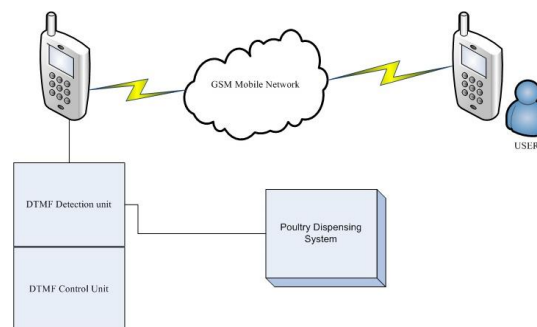

**Figure 1: Poultry feed dispensing system using GSM phone (DTMF) (Subramanian, 2013)**

### 1.1 Dual-Tone-Multi Frequency (DTMF)

Dual tone multi-frequency (DTMF) is a technology that can be used to send information through telephone lines. This information is in the form of acoustic sound having two frequency pair: high frequency group and low frequency group. The combination of these pair makes up eight frequency signals in pairs to represent sixteen number symbols and letters as shown in Figure 2

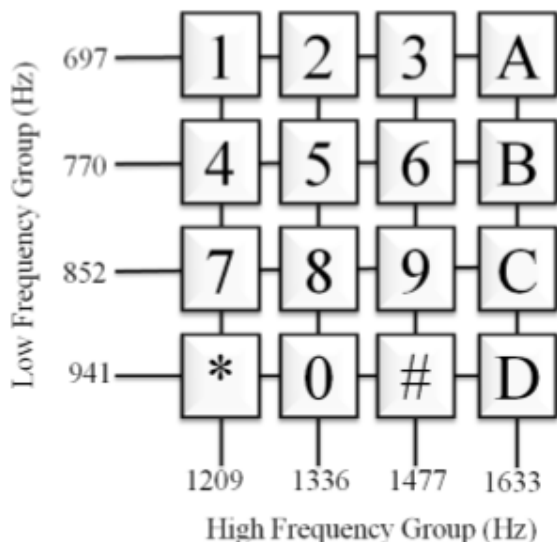

**Figure 2: DTMF Telephone tone keypad** (Subramanian, 2013)

Although the technology is not new, it is becoming popular in interactive control application. It is commonly used in Australia to decode calls typed numbers (Subramanian, 2013). DTMF is a generic name for pushbutton telephone signaling equivalent to the bell system touch tone (Beard *et al.*, 2012)

### 2. Literature Review

Several related literatures as regards the automated poultry feed dispensing system have been reviewed. According to (Adedinsewo, 2004), a computer program was the intelligence behind the system in which they designed and constructed a computer-controlled poultry feed dispenser and temperature regulator. The control part (computers) that contains the program was

separated from the mechanical system (dispenser) that acts on programs. These systems fully dependent on computer programs which are not real time operating systems and may lead to delay in system response. In their mode of operation, the system moves translationally in two positions (horizontal and vertical) which restricts it to its positioned.

Furthermore, an intelligent poultry feed dispensing system was proposed and developed by (Arulogun *et al.*, 2010). This was of great improvement that could

address the issues of real time processing. In it a microcontroller was introduced that effectively performs the task of personnel by computers in real time operation mode. A program was written in a chip known as microcontroller embedded in the systems. The systems catered for only solid feed, which therefore, could not make feedings of large number of birds uniformly achievable and it dispensed feeds on the floor. (Olaniyi *et al.*, 2013) introduced a new technique that caters for the liquid feeds by developing an intelligent poultry water dispensing system that made use of fuzzy logic control technique. Fuzzy logic is a control method that has the ability to imitate human intelligence based on predefined rules known as fuzzy rules. Input and output is carefully monitored in real life system that caters for liquid feeds.

Sam, *et al.*, (2001) proposed a design for uniformly delivering assigned feed ration to feed bunks associated with animal pen in a feedlot. The feeding operation is structured and tested among several individual operators. The performances of the individual operators were monitored and managed by a centralized operator using a satellite-based global positioning system. The design was not cost effective due to the use of advanced communication system. It was tedious to manage and therefore suitable only for large-scale production systems; in addition, it also requires high initial capital.

Patrick, *et al.*, (2008) also proposed design which consists of feed source, feed pan and a means of conveying feed from source pan. The system was not suitable for feeding poultry birds at the starting stage, which is considered to be a very critical time.

### 3. Materials and Method

#### 3.1 System Design

The System is made up of units and components as shown in Figure 3. The unit includes the power unit, display unit, microcontroller unit and mechanical dispenser system. These are built and cascaded together

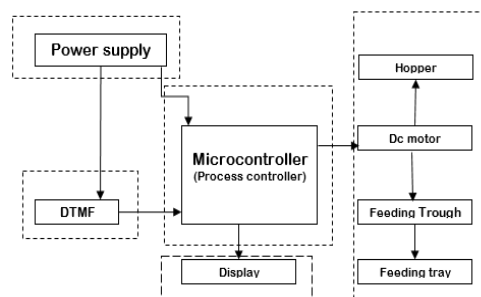

**Figure 3: Block diagram of the System**

- a) **Power supply:** Is the unit that supplies electrical or other forms of energy to the output or other group of Loads. The term is

mostly applied to electrical energy supply and less often to mechanical ones. In this context a 5v and 12v power supply were required for various modules in the project.

- b) DTMF Decoder Unit:** DTMF receiver is mostly used today in telephone receiver system. Receiver IC such as Motorola MT8870 is widely used in the electronic communication circuit. Beside its application in telephone, it has a wide range of application like home and industrial automation, remote control, radio communication etc. The 18 pin DTMF receiver must be designed to recognize a valid tone pair greater than 40ms in duration and to accept successive digit tone-pair that are greater than 40ms apart. However, for other application like remote control and radio communication the duration may differ due to noise considerations. This is achieved by adding an extra resistor and steering diode. Figure 4 shows the Implementation on proteus.

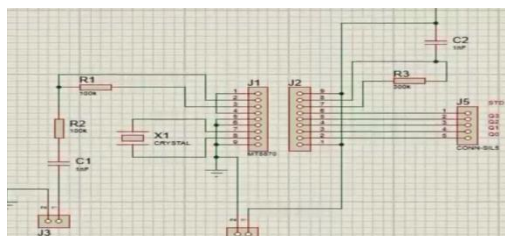

Figure 4: DTMF decoder circuit on proteus

- c) Display unit:** There is a standard which allows us to communicate with the vast majority of Liquid Crystal Displays (LCDs) regardless of their manufacturer. The standard is referred to as HD44780U, which refers to the controller chip which receives data from an external source (in this case, the PIC16F887) and communicates directly with the LCD. The 44780 standard requires 3 control lines as well as either 4 or 8 I/O lines for the data bus. The user may select whether the LCD is to operate with a 4-bit data bus or an 8-bit data bus. If a 4-bit data bus is used the LCD will require a total of 7 data lines (3 control lines plus the 4 lines for the data bus). If an 8-bit data bus is used the LCD will require a total of 11 data lines (3 control lines plus the 8 lines for the data bus) as shown in Figure 5.

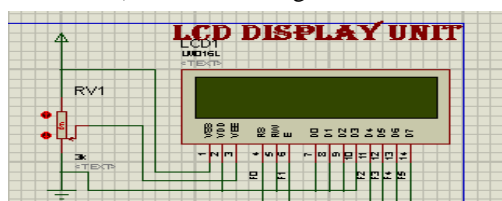

Figure 5: The LCD Display unit

- d) Microcontroller Unit:** The system inputs are connected through PORT RA0 – RA7 so that the required signal can be fed into the system from external source. In this case output from the DTMF decoder is fed in the input of the microcontroller. The output of the system is obtained from PORT B and D. The LCD and Light Emitting Diode (LED) depicts the level at which the system responds to the different input signals and also indicate the state of the system. The motor is connected to RB0-RB4 selected by the users. In the case of an 8-bit data bus, the lines are referred to as DB0-DB7. Figure 6 shows the image of PIC16f887 microcontroller captured in proteus Simulink.

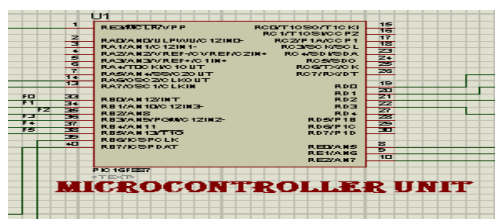

Figure 6: PIC16F887 in proteus

The model of the complete system setup on proteus is shown in Figure 7.

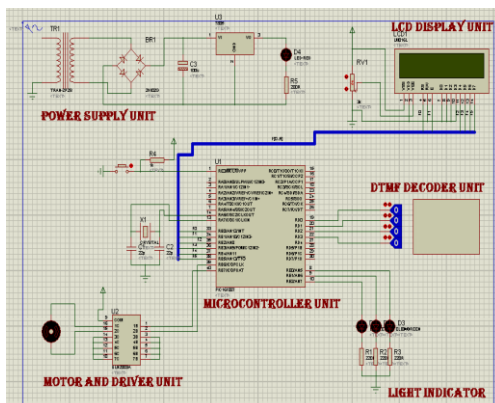

Figure 7: Complete system design on proteus

### 3.2 System Working Principle

Figure 9 shows a state diagram indicating the possible states that the system can have. A state machine is a machine that does not only depend on the input but also on the current state of the system. The circles indicate the state of the system while the arrows indicate the transition between states. Each state is divided into two halves; the upper half represents the state name while the lower half represents the state output. For every input to a state there are  $2^n$  output going out of the state. A state machine should be able to change state. From the diagram more than one transition line goes out of every state, meaning that it is possible for a state to go to any state regardless of the position. There are three transition line going into the system at initialization this implies that the system can begin at any state when powered on. In this paper 4-state is implemented, and

the 4-state is associated with DTMF key value on the phone keypad. One (1) represents state one, two (2) represents state 2, three (3) represents state3 and lastly, four (4) represents state four.

In order to successively change state or to achieve a proper transition between states, the user first of all goes to state four known as the reset state before going to any other state. However, if a transition is made without passing through state four, the system continues its current time. For example, if the timer is set to dispense every hour and the timer is at 22min, and the user decide to change to 30min dispense time, the system continues the time at 22min to dispense at 30min. note that a new state was set for 30min but it took 8min to dispense the first time thereafter it maintains it normal timing. The flow chart and the state diagram are shown in Figures 8 and 9 respectively.

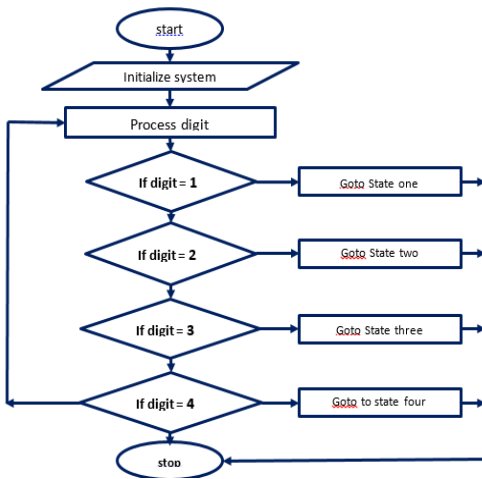

Figure 8: flowchart of the working principle

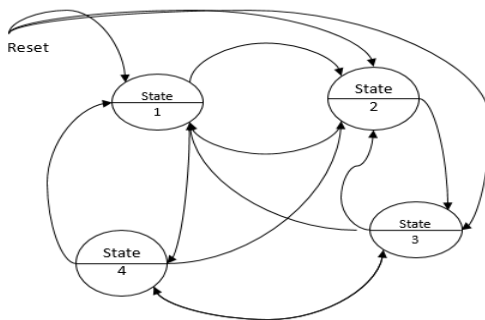

Figure 9: system state diagram

### 3.3 System Mathematical Model

In order to study the dynamic behavior of constructing system, the following mathematical equations are applied in determining the transfer function of the system from the conceptual model in Figure 10.

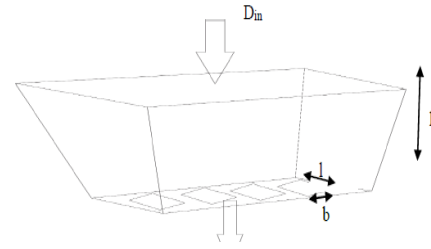

Figure 10: Conceptual model of the feeding trough

The flow rate of feed in and out of the hopper with consideration to area and length of the opening of the hopper

$$\frac{d(vol)}{dt} Din - Dout \tag{1}$$

$$vol = A * H \tag{2}$$

Where: A is the area (in squared metres) of the hopper dispensing hole, H is the height (in metres) of the dispensing hopper, and substituting equation 1 into equation 2 gives:

$$\frac{dAH}{dt} = Din - Dout \tag{3}$$

Dividing both side of equation 3 by H gives:

$$\frac{dA}{dt} = \frac{Din}{H} - \frac{Dout}{H} \tag{4}$$

$Din$  is the flow input to the system and it is expressed as a voltage to the DC motor. The voltage is proportional to the rotation speed  $Din = aV$ . Where,  $a$  is a constant equal to the ratio of rotation speed to voltage.

$Dout$  is the amount of feed that flows out of the hopper dispensing holes per unit time.

Thus,  $Dout = bA$ , where  $b$  is a constant equal the ratio of the amount of feed per total area of the opening.

$$SA = \left(\frac{aV}{H}\right) - \left(\frac{bA}{H}\right) \tag{5}$$

$$\frac{SA}{V} = \left(\frac{a}{H}\right) - \left(\frac{b}{H}\right) \frac{A}{V} \tag{6}$$

$$\frac{A}{V} \left(S + \frac{b}{H}\right) = \frac{a}{H} \tag{7}$$

Transfer function is the ratio of output area to the input voltage, thus, the Transfer function of the system is given as:

$$G(s) = \frac{a}{SH + b} \tag{8}$$

## 4. Results and Discussion

The system was tested for performance based on response to input by the controller. A series of eight trails were taken and their associated response time were recorded as shown in the Table 1.

**Table 1: Trials and Response reading**

trials	Response(seconds)
1	0.5
2	0.7
3	1
4	0.56
5	0.8
6	0.4
7	0.7
8	0.9

The graph of response time vs trials is plotted and shown in Figure 11.

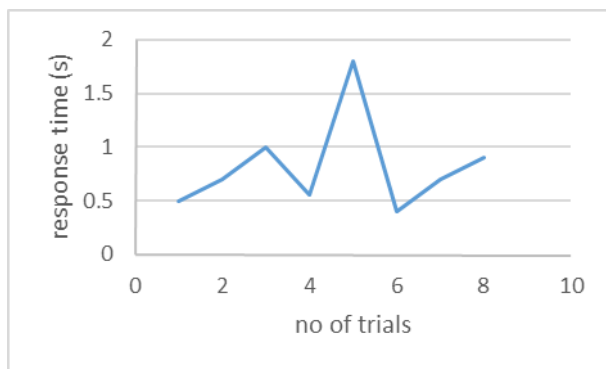

**Figure 11: plot of response time vs number of trials**

## 5. Conclusion and Future work

This project has demonstrated practical effort regarding the improvement in performance of existing solid feed dispensing system. A remote control method using DTMF was used to control the interval of dispensing of feed in the system. The significance of the remote control was to help the farmer determine a feeding plan of his/her birds. The use of DTMF has a wide range of coverage in term of control, whereby farmer can communicate with his/her system anywhere in the world with network coverage. This reduces intensive manual Labor of feeding birds at precise interval in a deep litter poultry farming system, and enables the farmer to determine feeding plans. The designed system has reduced stress, contributed to cost benefits, high profit, yield and making feeding to be hygienic on poultry farms.

The remote-controlled poultry feed dispensing system can be improved upon by introducing appropriate

sensor to monitor the feed level and control the rate of dispensing at night when birds feed less so as to improve cost benefits and reduce a minimal level of human intervention. The mechanical hardware can only feed 12 birds at a time. Therefore, the design can be worked upon to feed larger number of birds.

## REFERENCE

- Adedinsewo, O. (2004). *Design and construction of a computer controlled poultry feed dispenser and temperature regulator*. Ogbomosho: Ladok Akintola University of Technology.
- Arulogun, O. T., Olaniyi, O. M., Oke, O. A., & Fenwa. (2010). Development of mobile intelligent poultry feed dispensing system. *Journal of engineering and applied sciences*.
- Beard, J. H., Given, S. P., & young, B. J. (2012). *A discrete fourier transform based digital dtmf detection algorithm*. Mississippi state university.
- Olaniyi, O. M., Salami, A. F., & Adewunmi, O. O. (2013). Design of an intelligent poultry water dispensing system using fuzzy logic control technique. *In proceeding of international multidisciplinary conference on research, developments and practices in science*.
- Oluyemi, J., Robert, A. (2002). *Poultry production in warm wet climate*. MacMillan, Nigeria.
- Patrick, M. W. (2008). *Feeding System Employing an Adjustable Dispenser Outlet*. united state patent, 119/153.
- Romolaran, A. K., Ademiluyi, I. O., & Jenifar, H. O. (2013). Challenges of small poultry farm in ibadan oyo state nigeria. *Global journal of science frontier research agriculture and veterinary sciences*.
- Sam , J. T., James , C., Micheal , A., & Arlen, A. (2001). *Apparatus and method for uniformly delivering feed ration along feed bunk using global positioning*. united state patent 5.
- Subramanian, v. R. (2013). Application of dual tone multi frequency technology and sensing in autonomous robotic navigation. *International journal of research in engineering and technology eissn*, 02(09).

## Biography of Authors

**Aliyu Ahmed** had his B. Eng (Electrical and Electronic Engineering) from the Federal University of Technology Minna and his MSc in Computer Networking from the

University of Bedfordshire, UK. He now lectures at the Department of Computer Engineering, Federal University of Technology, Minna, Niger state, Nigeria.

**Olayemi Mikail Olaniyi** is a Senior Lecturer in the Department of Computer Engineering, Federal University of Technology, Minna, Niger State, Nigeria. He obtained his B. Tech in 2005 and M.Sc. in 2011 in Computer Engineering and Electronic and Computer Engineering respectively. He had his PhD in Computer Security from the Department of Computer Science and Engineering, Ladoke Akintola University of Technology, Ogbomosho, Oyo State, Nigeria in 2015. He has published in reputable journals and learned conferences. His areas of research includes: Computer Security, Intelligent Systems, Embedded Systems, Telemedicine and Precision Farming.

**Eustace M. Dogo** had his BSc and MEng in Electrical Engineering in 1996 and 1998 respectively from Saint Petersburg State Polytechnical University, Russia. He has working experience as an Information Technology expert in areas of Network Administration and Network Security Development & Deployment in Financial Institutions in Nigeria, as well as a Field Engineer with Schlumberger in Nigeria and Europe. He is now with the Department of Computer Engineering, Federal University of Technology, Minna, Niger state, Nigeria. His research interest includes Wireless Sensor Networks, Artificial Intelligence, Computing Network and Cloud Computing.

**James E.** is a graduate of the Department of Computer Engineering of the School of Engineering & Engineering Technology, Federal University of Technology Minna, Niger State, Nigeria. His area of interest is in Embedded system and Precision Agriculture.