



Design of a Mobile Poultry Liquid Feed Dispensing System Using PID Control Technique

Olaniyi, O. M., Folorunso, T.A, Akogbe A. M, Adejumo A.

Department of Computer Engineering

Federal University of Technology, Minna, Nigeria

Email:{mikail.olaniyi;funso.taliha;micheal.akogbe}@futminna.edu.ng;adejumoabidemi246@gmail.com

ABSTRACT

Poultry liquid feed poisoning, poor growth, death of poultry birds and low production yield has been a major problem faced by poultry farmers. Feeding poultry birds is an operation that must be done properly and carefully. The feeding operation is dependent on the poultry farming system practiced. The feeding mechanism could be done manually or with automated system. This paper presents the design of a mobile poultry liquid feed dispensing system using Proportional Integral Derivative (PID) control technique. The performance of the system was evaluated without and with the PID controller and the result shows an improved and better performance for the system with the PID controller. The developed system was able to move from the starting point to the destination while dispensing liquid feed to the poultry birds and once the feeding time is completed, the system returns to the starting point for refilling using Proportional Integral Derivative (PID) control technique for reduced labour and high profit yield in poultry feeding management

Key words: PID controller, System performance, MATLAB simulations, Proteus ISIS simulation, Liquid Dispensing, Poultry, Deep litter

1. BACKGROUND TO THE STUDY

A lot of small scale and subsistent poultry farmers in the rural areas has been frustrated running poultry farm because of the little or no profit from the poultry business. About 75% the cost of managing a poultry farm goes to the poultry feed (Odunsi, 2009). As the number of birds increases, the stress and challenges of attending to them increases. The identified challenges includes but not limited to the waste of time and energy on the human part, wastage of feeds, birds diseases and infections (Sainsbury, 2001).

In the past numerous systems have been developed to address these aforementioned challenges in the dispensary of Liquid and Solid feeds. However most of these systems are faced with the challenge of mobility and limitation on the type of feeds that can be dispensed. In this work, we present the design of mobile system that has the capability of dispensing both liquid and solid feeds in other to solve the problem posed by the existing systems. However the design presented herein focuses only on the liquid type of feed for the poultry farm.

The remaining part of the work is divided into 4 sections. Sections 2 focuses on the review of related past works, Section 3 discusses the system design. In section 4 the results are presented herein and the conclusion as well as the recommendations are presented in section 5.

2. REVIEW OF RELATED WORKS

The design of an automatic dry food feeder with the capability of dispensing only dry feed to birds in specific quantity and at stipulated time was proposed in Mezhinsky (1993). The designed system has a short coming of statically dispensing dry feed to poultry birds.

In Arulogun *et al.*, (2010), a mobile intelligent poultry feed dispensing system was designed and developed. The system dispenses solid feed to poultry birds in deep-litter poultry feeding system while sensing obstructions. The designed system could move from one point to another and it could avoid obstructions while in operation. The system could only dispense solid poultry feed, which cannot be eaten by chicks and the dispensation method of the feed was not hygienic. In Olaniyi *et al.*, (2014), an intelligent and statically dispensed poultry feed dispensing system using fuzzy logic control technique was proposed. The designed system improved on the limitation of Arulogun *et al.*, (2010) feeding system. However still have some limitations such as static mode of liquid feed and solid feed dispensation could lead to contamination of the liquid feed; the system could not feed large number of poultry birds and also requires high level of human involvement.

Similarly, an intelligent poultry liquid feed dispensing system using fuzzy logic control technique was developed by Adewumi (2014). The design is akin to that of Olaniyi *et al.*, (2014) in the use of fuzzy logic Control. However, the system was immobile in dispensing the liquid feed. In Omosebi (2006), a microcomputer controlled solid feed dispensing system was developed. The system could not sense obstruction while operating but could only move in horizontal and vertical direction axis. The high dependence on personal computer control system limits the use and operation of the proposed system. Thus, the limitations in aforementioned review indicated that there is a need for improvement on the existing works done so far due to some of the specific limitation of the systems such as: Inability to control their system (Victor, 1993); Unhygienic method of feed dispensing and wastage (Arulogun et al 2010); High cost of maintenance (Omosebi, 2009), feeding few birds (Adewumi, 2014), inability to move and feed large number of birds (Adewumi, 2014) and the long settling time and rise time in Olaniyi *et al.*, (2014). In lieu of the above limitations, this paper proposes the design of a mobile poultry liquid feed dispensing system using PID control technique in deep litter poultry system.

3. SYSTEM DESIGN

This section describes the methodology used in the design of the proposed mobile poultry liquid feed dispensing system

3.1 System Overview

The schematic diagram of mobile dispensing system is as shown in Figure 1, it consists of different parts, among these parts are: trough, wheels, drinkers, liquid feed pumps and liquid feed hose.

The operation of the proposed system is such that when the trough tank of the system is filled to the brim and a button is pressed the system move forward, the upper liquid feed pump dispense the liquid feed to the drinkers for the poultry birds and the lower liquid feed pump begins to dispense the liquid feed back to the trough. The dispensing is being controlled by the PID controller thereby reducing wastage of liquid feed and also preventing of liquid feed from contamination.

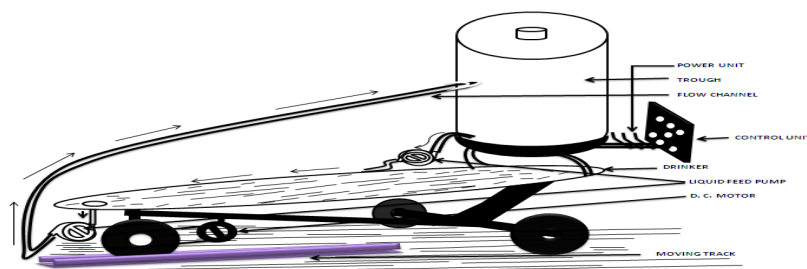

Figure 1: Schematic of the Mobile poultry liquid feed dispensing system.

The liquid feed dispensing system is divided into different units among which includes, power supply unit, mechanical unit and liquid dispensing unit as shown in Figure 2.

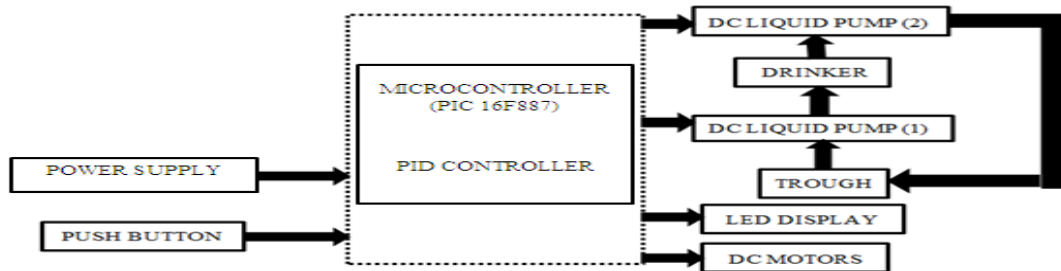

Figure 2: Block diagram of the Proposed Design

3.2 Hardware Design Consideration

The hardware section of the proposed system is segmented into subunits namely , the PID control unit, display unit, microcontroller unit, dispensing unit, mechanical unit, power unit and the reset unit as shown in Figure 3.

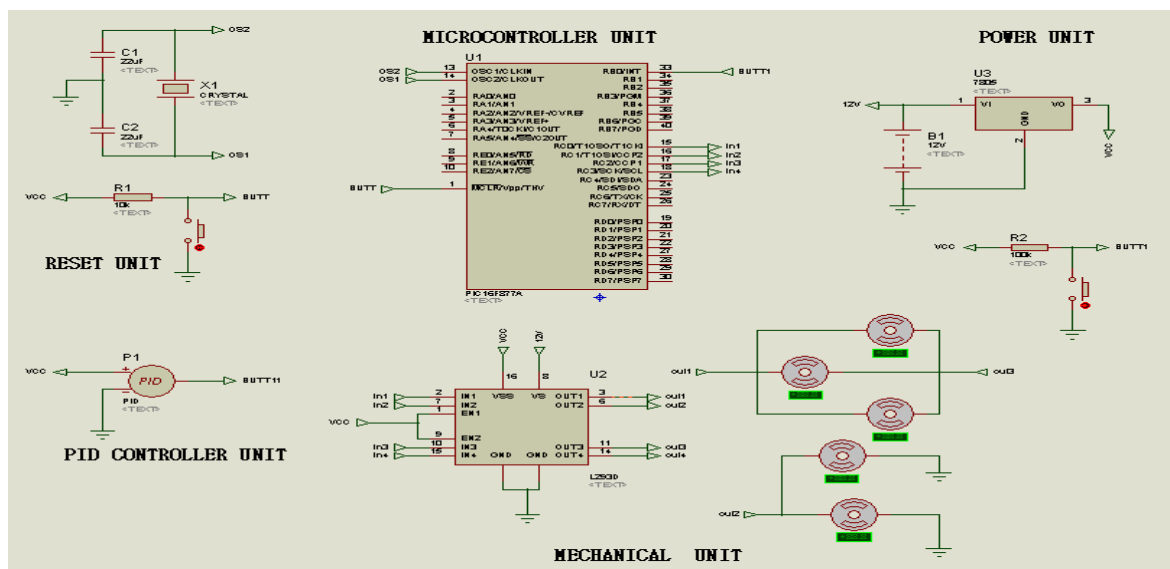

Figure 3: Electronic circuit diagram of Proposed System

3.3 Software Design Consideration

MATLAB 2009a and the Simulink were adopted to implement the PID Controller and also auto-tune the controller in order to aid the system to have a good response time, rise time, steady state and also reduced the damping nature of the system performance. The MicroC programming software was used for the programming of the PIC 16F887A microcontroller chip which aids the timing of the system movement and liquid dispensation. The combination of the software Design and the Hardware Design constitute the complete design of the proposed system. The operating principle of the system is as depicted in the flow diagram in Figure 4. Once the system is powered ON, the system moves forward



from the starting point, to the destination where the poultry birds are. Then the system begins the dispensing operation the liquid feed in a recycling manner to prevent contamination by small insects. When the feeding time which is equal to the dispensing time is completed, the system moves in a reverse direction to the starting point to refill drinker via the PID controller. Thereafter the system moves to another predefined direction. The overall completed design of the system is presented in Figure 5.

3.4 System Mathematical Model

The system was modeled based on the relationship of the input and output of the system. The mathematical model was obtained via the application of laws of conservation of mass, flow rate and the change in volume of the liquid feed in the trough and drinker. With appropriate insertion of the dimensions and variable into the modelling procedure the linearized system model Transfer function is as presented in equation 3.1.

$$G(s) = \frac{8.5}{s + 0.07142} \quad (3.1)$$

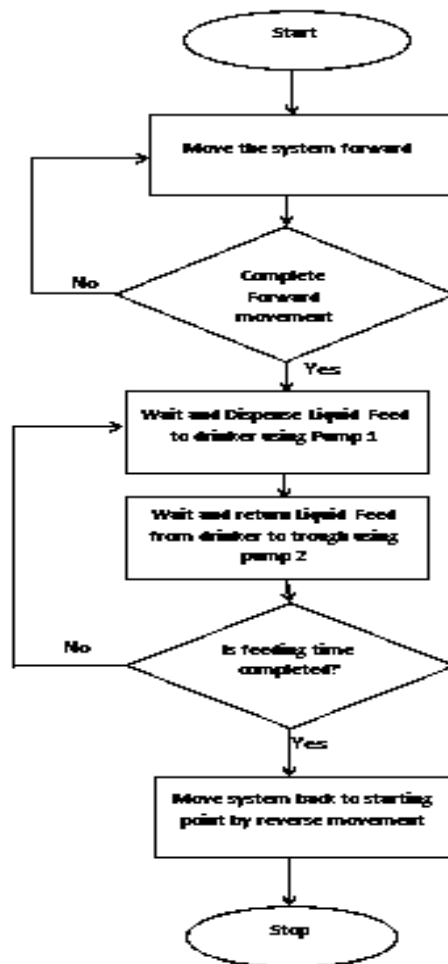

Figure 4: Flowchart diagram of mobile poultry liquid feed dispensing system



Figure 5: The final developed mobile intelligent liquid feed dispensing system

4. RESULTS AND DISCUSSIONS

The transfer function (in equation 3.1) was analyzed using the MATLAB simulation and the rise time and the settling time were obtained. MATLAB 2009a environment was used for the simulation of the system response and the performance of the system Controller. The Ziegler Nichols (Z-N) Tuning technique was adopted to tune the PID Controller in quest to obtain its parameters K_p , K_i and K_d corresponding to the proportional, integral and derivative gain. The values of the PID controller parameters (K_p , K_i and K_d) were obtained as follows after appropriate tuning using the Z-N technique, $K_p = 1200$, $K_i = 250$ and $K_d = 100$. The performance of the system with the Z-N Tuned controller and without the controller is as presented in Figure 6.

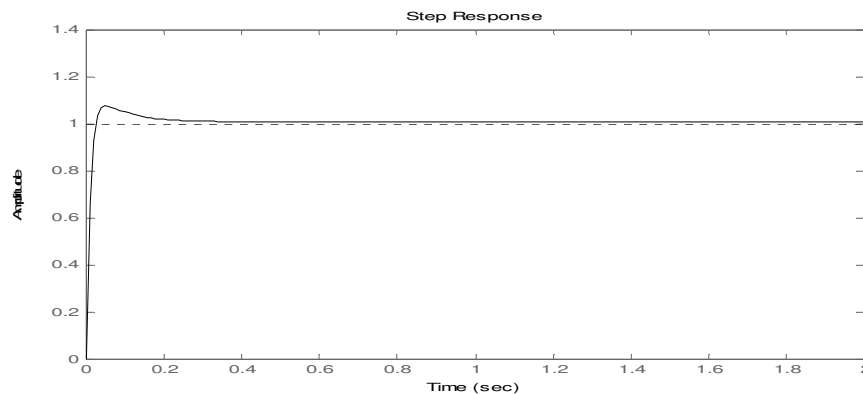

Figure 6: The System Response

The performance evaluation of the system was based on the Rise Time T_r , the settling Time T_s and overshoot as well as the steady state error. The parameters values are as presented in Table 4.1.

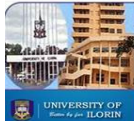

Table 4.1

	Without PID	Z-N Tuned PID
Rise Time(sec) Tr	>2	0.0174
Settling Time(sec) Ts	>2	0.188
Over Shoot (%)	>20	5
Steady Error ess	>3	0

5. CONCLUSION AND RECOMMENDATIONS

In this work, a detailed review into the challenge faced by poultry farmers with respect to feeding their birds has been carried out with a view of proposing an improved technique to solving these challenges. We have successfully presented the design and development of an improved mobile liquid feed dispensing system. The system has the mobility capability as well as the dispensing is been controlled via a Z-N Tuned PID controller. With developed prototype, farmers will be relieved of stress of human involvement in the administration of poultry liquid feed to birds for high return of investment in poultry production and also it would provide a reduce risk of food contamination. However, the following are open design issues for future researchers in this area of precision agriculture:

- a) The PID controller design can be further improved on by using intelligent techniques like genetic algorithm and particle swarm optimization, firely and combination of these techniques.
- b) Adding sensors like level sensors, pressure sensors, light sensors and light sensors can also be added to the design.
- c) Battery charger can also be inputted to the design to prevent power failure.
- d) Remote control and communication can be added to the dispensing system.

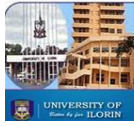

REFERENCES

1. Adewumi, O., O. (2014). Design and Development of an Intelligent Poultry Liquid Feed dispensing System, B.Eng Dissertation, *Federal University Of Technology Minna, Niger state*.
2. Adewuyi, A. P. (2013). DC Motor Speed Control: A case between PID Controller and Fuzzy Logic Controller. *International Journal of Multidisciplinary and Sciences and Engineering*, 4.
3. Arulogun, O. T., Olaniyi O.M., Oke, O.A., and Fenwa, D.O., (2010). Development of Mobile Intelligent Poultry Feed and Water Dispensing System. *Medwell journals of Engineering and Applied Science*, 5(3), 229 - 233.
4. Banhazi, T. M., Black, J. L. (2009). Precision livestock farming: A suit of electronic systems to ensure the application of best practice management on livestock farms. *Australian Journal of Multidisciplinary Engineering*, 7, 14.
5. Black, J., Cook, P., Marr, G., Skirrow, S., Hitchens, B., Frey, B. (2002). Improving herd reproductive performance through recording analysis and action. *australia Pork Limited , caberra, Australia*.
6. Farayola, C. O., Adedeji, I. A., Amao, S. A. (2013). Determinants of participation of small scale. *World journal of agricultural research*, 1(5), 96-100.
7. Frame, D., David. (2008). principles of feeding small flocks of chicken at home. *Extension and Agriculture, Utah state University, U.S.A*.
8. Gates, R. S., Banhazi, T. (2002). Applicable technologies for controlled environment systems (CES) in Livestock Production. 24, 4.
9. George, L. (2013). DC Motor Speed Control using PWM with PIC Microcontroller. *MicroC / Pic Microcontroller / tutorials*.
10. Labcenter, E. (1989-2009). Proteus and ISIS. <http://www.labcenter.co.uk>.
11. Mark, Z. (2011). Microcontroller. www.programmingTipsgp2d12.htm.
12. Odunsi, A. (2009). A practical approach to animal production and health. *oluseyi Press, Ibadan*.
13. Olaniyi, O. M., Salami A.F., Adewumi, O.O., Ajibola O.S. (2014). Design of an intelligent poultry feed and water dispensing system using fuzzy logic control Technique. ", *Journal Of Control Theory and Informatics (JCTIS)*, Vol.4, No.9 , pp. 61- 72.
14. Omoisebi, B. (2006). Development of a self-propelled poultry feed dispenser with Feed level detector. *B. Tech. Dissertation, Department of Computer Science and Engineering, Ladoke Akintola University of Technology, Ogbomoso, Nigeria*.
15. Peterson, M. (2008). Poultry Diseases. *Elsevier Health Sciences*, 550.
16. Roberts, F. A., Oluyemi, J.A. (2002). Poultry production in warm well climate.
17. Smith, B. (2002). Classical vs Intelligent Control. *Memorial University*.
18. Srinivas, P., Vijaya, Lakshmi, K ., Naveen, Kumar, V. (2013). Design of GA based PID Controller for three tank system with various Performance Indices. *International Journal of Soft Computing and Engineering (IJSCE)*, 3(5), 206 - 209.
19. Theraja, B. L., Theraja, A.K., Tarnekar, S.G. (2005). Electrical Technology. *published by S. Chand and Company Ltd. 7361, ram nagar new dehi -110 055 1*.
20. Victor, M. (1993). Automatic Dry Food Feeder For Animals. *united state of America patent*, 5, 300 -530.
21. Williams, C., Pratt. (1991). Computerized process and system for assigning and delivering feed to animals in a Feed lot *United state patent*, 5, 008 & 821.