

# RF energy harvesting system for charging mobile phones

Nuhu Bello Kontagora<sup>1</sup>, Idris Aji Dauda<sup>1</sup>, Yahaya Zurmi<sup>1</sup>, Nanre Banwat Sharon<sup>1</sup>, Sangwon Oh<sup>2</sup>, Ibrahim Aliyu<sup>2</sup>

<sup>1</sup> Department of Computer Engineering, Federal University of Technology, Minna, Nigeria

nuhubk@futminna.edu.ng, idris.dauda@futminna.edu.ng, yahayazurmi@gmail.com, nanrebanwat@gmail.com

<sup>2</sup> Department of ICT Convergence System Engineering, Chonnam National University, Gwangju, 61186, South Korea

osw0788@gmail.com, ibal2010@yahoo.com

**Abstract.** As mobile phone consumers demand mobility and convenience in charging/recharging the batteries, there is a need to consider new recharging methods from the conventional method. This paper examines the levels of energy that can be harnessed from the atmosphere and achieve power sufficient to charge a mobile phone. This is achieved by collecting the ambient frequency signals in the air using an antenna and sending the collected signal to a voltage multiplier circuit that converts it into a DC signal. The DC signal is then stored in a super-capacitor and used to charge a mobile phone. Unlike previous works, we proposed using a voltage doubler and battery storage for a steady system. The proposed system shows a significant efficiency in harness RF energy for mobile phone charging.

**Keywords:** RF energy harvesting system, DC signal, mobile phone charging

## 1 Introduction

Mobile phones have become an integrated part of our lives, with current users at about 7.26 billion, accounting for about 91.54% of the population [1]. However, the phone requires power energy recharging to perform its function. Existing techniques of charging power mobile phones include directly plunging the mobile to a power source, power banks, solar power phone charges or wireless power transfer. However, the charging and recharging of mobile phones have become a key challenge as the demand for mobility and convenience is ever-increasing. With wireless



This is an Open Access article distributed under the terms of the Creative Commons Attribution Non-Commercial License (<http://creativecommons.org/licenses/by-nc/3.0/>) which permits unrestricted non-commercial use, distribution, and reproduction in any medium, provided the original work is properly cited.

 **JCC** © Journal of Contents Computing

Vol. 4, No. 1, pp. 401-416, Jun. 2022

Received 01 April 2022

Revised 21 April 2022

Accepted 05 May 2022

\*Corresponding Author;

Nuhu Bello Kontagora

Tel: 

E-mail: [ibal2010@yahoo.com](mailto:ibal2010@yahoo.com)

power transfer, there is mobility and convenience to some extent, but the major limitation is power can only be transferred within a certain distance.

Energy harvesting is one of the best techniques for recharging mobile phones, which logically results in increased autonomy of the device and guarantees convenience. There are vast sources of energy that can be harnessed; examples are; human movements (kinetic energy harvesting), body temperature (Seebeck and Peltier effects) as well as ambient energy such as solar and Radio Frequency (RF) waves. In particular, RF is an electric energy that travels through the air by ionizing the medium on its paths. The RF energy can be easily found in the surroundings as it is used widely by many industries and devices like television broadcasting, telecommunication, microwave etc. It is always available, free and efficient.

The main purpose of this study is to examine the levels of energy that can be harnessed from the atmosphere and to achieve power that is sufficient enough to charge a mobile phone. This is achieved by collecting the ambient frequency signals in the air using an antenna and sending the collected signal to a voltage multiplier circuit that converts it into a DC signal. The DC signal is then stored in a supercapacitor and used to charge a mobile phone. We proposed using a voltage doubler and battery storage for a steady system. Thus, we set out to achieve the following key objectives:

1. Design a Radio Frequency harnessing system for charging the mobile phone
2. Simulate and implement the design in (1)
3. Evaluate and validate the implemented system's performance using percentage conversion and charging efficiency.

The rest of the paper is organized as follows: Section 2 presents related works, section 3 discusses the methodology and system implementation, section 4 presents the results, and section 5 concludes the paper

## 2 Related Works

RF energy harvesting circuit is principally based on the voltage multiplier circuit, which was invented by Heinrich Greinacher in 1919. There are two major arrangements of RF energy harvesting circuit, Villard voltage doubler, sometimes also called Cockcroft-Walton voltage multiplier and Dickson voltage multiplier. According to Yan, et al. [2], Both Villard and Dickson's topology reveals no significant difference in performance. However, Villard topology is adopted in this study because it employs a parallel configuration of capacitors in each stage, reducing the circuit impedance and simplifying the matching task. The review of related studies is provided as follows

Shinki, et al. [3], described the design of a high-efficiency radio frequency energy harvesting circuit system with an integrated microstrip antenna. The circuit comprises a series of resonance and boost rectifier circuits for rectifying radio frequency signals into enhanced direct current (DC) voltage. They obtained an output DC voltage of 5.67 V for an input of 100 mV at 900 MHz. The antenna input impedance matching was optimized for maximum power transfer. An efficiency of about 60% was measured for 4.85 dBm input power and a load resistance of 20 kW at 905 MHz using an antenna-integrated energy harvester. However, the radio frequency source for this work is dedicated, and the power with which the frequency is transmitted is predetermined. Adam, et al. [4], described the design and implementation of a 7-stage doubler for RF energy harvesting. A modified Dickson configuration was used for this work, which consists of two HSMS 2850 Schottky diodes and two capacitors for each stage. Their aim was to analyze the performance of a dickson configuration voltage doubler and matching network in RF energy harvesting. Simulation results show an advance for the doubler circuit with a matching network compared to the doubler alone. They achieved a Maximum of 60% improvement in rectified output at low input power. However, this design was only simulated and there was no implementation. Also, Krishnachaitanya and Pushpalatha [5] proposed using a quarter-wave whip antenna to target the 915Mhz frequency. The antenna is similar to that used on car radios-It was used because of its fairly large operating frequency range. This was helpful because an antenna's precise tuning is not required. A voltage multiplier was used to rectify the signal gotten from the antenna. For proper operation of a quarter-wave whip antenna, a relatively large ground plane is needed, affecting the system's compactness.

Furthermore, Schauwecker [6] introduced the incorporation of a band-pass filter and a matching network along with other RF energy harvesting circuitry. The antenna used to test the processing circuitry proposed in this study was fabricated to target two frequency bands: the 2.4GHz WiFi band, which involves frequencies in the range of 2.41GHz-2.46GHz, and the 5GHz WiFi band, which involves frequencies in the range of 5.18GHz-5.82GHz. The design was performed with an emphasis on channel 6 of the 2.4GHz WiFi band (2.426-2.448GHz), as this is the frequency band on a majority of WiFi routers. However, the involvement of a band-pass filter makes the design more complex and increases the overall cost of the system. Meanwhile, a rectifying antenna (rectenna) was also employed to harvest ambient RF energy from cell phone towers at 900 MHz GSM band [7]. The proposed circuit was a combination of rectifying circuits using Schottky diode and RMPA for microwave (RF) to DC conversion. The designed rectenna design has proved to be a low-cost device for wireless power transfer and RF energy harvesting. GSM900 band was used as it is the most commonly used band for mobile communications. This rectenna has a return loss of around 17 dB at a frequency of around 900 MHz. This design can be improved by adding a matching network for maximum power transfer. Narayana, et al. [8] proposed the use of a rectenna-based rectangular microstrip patch antenna and rectifier designed at 2.45GHz with a return loss of less than -20dB. A microstrip patch antenna was chosen for this work because of its

lightweight, planar structure, and low profile. The design of the Rectenna is achieved using AWR for energy harvesting. Finally, the performance of the fabricated system (Rectenna) was measured on the network analyzer which was closely matched with a loss of around -20dB and an impedance of about  $50\Omega$ . However, this system targets a single frequency band which is not always available in the ambient environment.

In addition, Uzun [9] considered all the available parameters and designed a new triple band RF energy harvester by using Advanced Design System (ADS) simulation software. The proposed design is more efficient with its current form and provides broadband working frequencies. The output power and efficiencies of each circuit have been obtained from the software by using different input RF power, load resistance and the number of stages in voltage doubler at WiFi 2.45 GHz, DTV 575 MHz and GSM 900 MHz frequencies. This makes up a triple band RF energy harvester. The system conversion efficiencies for various input power levels are about 30% at 2.45 GHz, 55% at 575 MHz and 45% at 900 MHz. The average conversion efficiency is obtained to be 43% for the three systems. This conversion efficiency can be increased by integrating a matching network between the antenna and the rectifying circuit for maximum power transfer. Sivaramkrishnan and Jegadishkumar [10] proposed the use of an ideal power source offering an impedance of  $50\Omega$  to deliver power ranging from -5dBm to 40dBm. This RF power range was considered because the RF signals transmitted from the network towers travel at a power ranging from -5dBm to 40dBm. A resonant circuit was also included, which resonates in the frequency range of 0.9GHz to 1.8GHz. This is the frequency range the mobile service providers are allowed to transmit, hence why they chose this frequency range. The resonant circuit was obtained by adding an inductor to the circuit. In order to cover a wide band, the inductor's quality factor is stepped down by adding resistance to the inductor. This helps in boosting the output power for a range of frequencies. The RF range can be modified by tuning the impedance matching circuit, which also acts as a resonant circuit. However, this work does not exploit the boosting ability of a voltage multiplier circuit. Also, Nintanavongsa [11] proposed a dual-stage RF energy harvesting system composed of a seven-stage and ten-stage design, the seven-stage being more receptive in the low input power regions. In contrast, the ten-stage is more appropriate for a higher power range. Each stage was made to be a modified voltage doubler. Secondly, the design was fabricated on a printed circuit board to establish how such a circuit can run a commercial Mica2 sensor mote. With a simple yet ideal dual-stage design, this experiment revealed approximately 100% enhancement over other existing RF energy harvesting systems in the power range of 20 to 7 dBm. However, this system can be improved by adding a suitable matching network.

### 3 Methodology

This section discusses the design and implementation of the RF energy harvesting system. As shown in the block diagram in Figure 1, the system has an antenna and three other functional blocks. The functional blocks include the matching network, RF-DC converter, and charging circuit. Further details of the system design and implementation are discussed in the next sections.

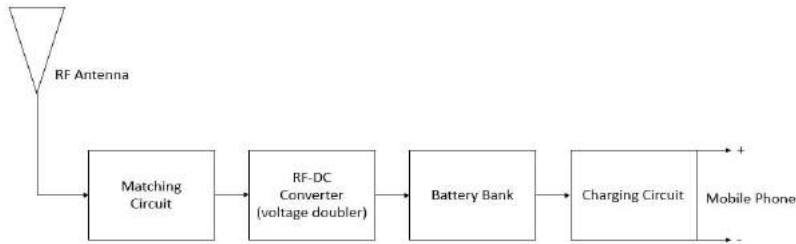

Fig. 1 System Block diagram

#### 3.1 System Design

The architecture of the developed system is presented in Figure 2. The incident RF power is converted into DC power by the voltage multiplier. The matching network, composed of inductive and capacitive elements, ensures the maximum power delivery from the antenna to the voltage multiplier. The energy storage ensures smooth power delivery to the regulating circuit, which regulates the output voltage. A power cable is attached to the output, which is used to charge the mobile phone.

The flow chart of the system is illustrated in Figure 3. The design considerations are informed by considerations such as; increasing the number of multiplier stages, giving higher voltage at the load and yet reducing the current through the final load branch. This may result in unacceptable charging delays for the energy storage capacitor. Conversely, fewer stages of the multiplier will ensure quick charging of the capacitor, but the voltage generated across it may be insufficient to charge a mobile phone. Along similar lines, a slight change in the matching circuit parameters significantly alters the frequency range in which the energy conversion efficiency is maximum, often by several megahertz. Hence, RF harvesting circuits involve a complex interplay of design choices, which must be considered together. We address this problem by considering a multistage design of the voltage multiplier.

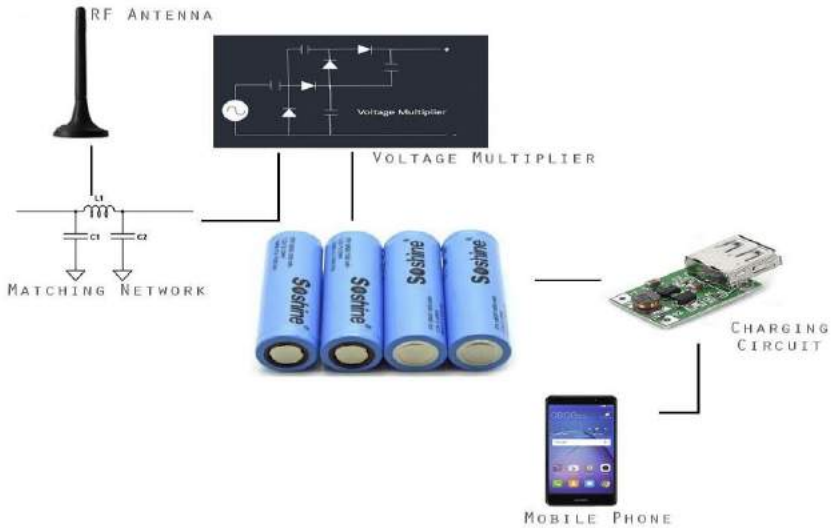

Fig. 2 Architecture of the system

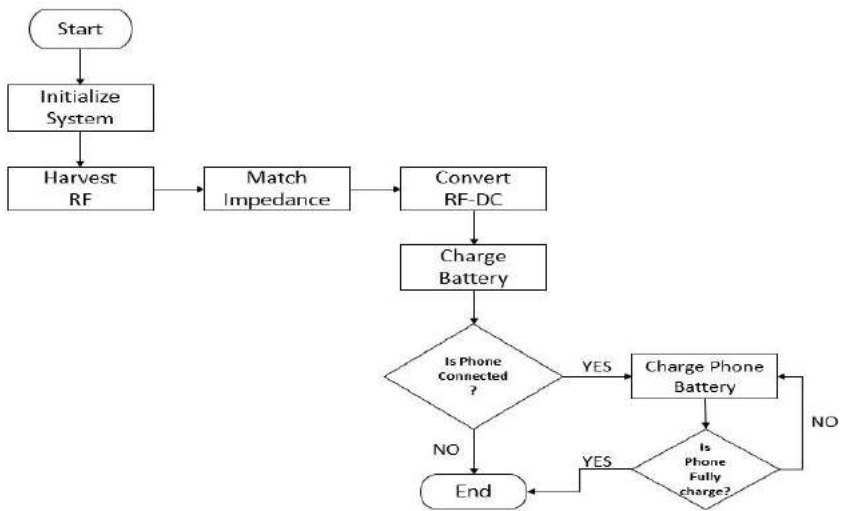

Fig. 3 System's flow chart

### 3.2 System Implementation

The first stage in an RF energy harvesting circuit is a receiving antenna with the ability to capture ambient RF signals. While this work does not involve the design of an antenna, the basic characteristics of antennas will be discussed, as the anten-

na's performance will impact the design and selection of components for the processing circuitry. In the most basic sense, a receiving antenna converts an electromagnetic wave propagating in free space into an RF signal propagating on a transmission line. Most antennas exhibit a property known as reciprocity, meaning the antenna will have the same radiation pattern for transmission and reception. The antenna used for this design is a 4G LTE antenna, which covers all mobile network bands.

Matching network has a very crucial task to reduce losses which are known as transmission losses resulting from signal loss between antenna and rectifier circuit. Impedance matching is an important term associated with it. The antenna is said to be perfectly matched or has impedance matching if the antenna's output impedance and the load's input impedance are conjugates. For this study, a simple Series lumped element inductor and quarter wavelength short circuit shunt stub is going to be used to achieve 50  $\Omega$  impedance (see Figure 4).

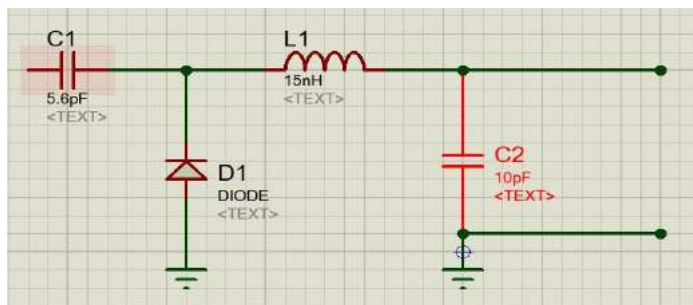
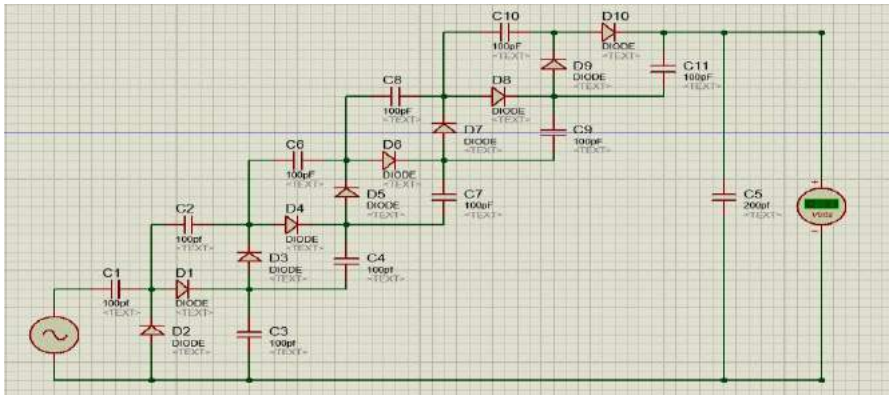

Fig. 4 Matching Network Simulation

A voltage doubler was simulated on the Proteus simulation tool. A Villard voltage doubler approach was adopted for this work, and it is designed in five stages, as shown in Figure 5. The number of stages in the system has the greatest effect on the output voltage. The capacitance, both in the stages and at the end of the circuit, affects the speed of the transient response and the stability of the output signal. The number of stages is directly proportional to the amount of voltage obtained at the system's output. Generally, the output voltage increases as the number of stages increases. For this study, a five-stage voltage doubler is adopted.

The voltage doubler was implemented on a dotted Vero-board. The components that constitute the circuit are diodes and capacitors. After some design calculations, it was ascertained that the capacitor values needed are 100 $\mu$ F and Schottky diodes were selected for their very low forward voltage. Figure 6 shows the voltage doubler implementation.



**Fig. 5 Voltage Doubler Simulation**

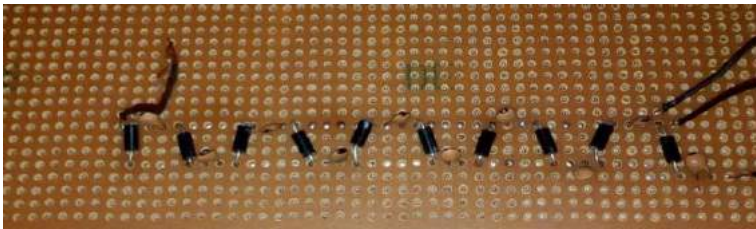

**Fig. 6 Front-View of the Voltage Doubler implementation**

As one can easily guess, the output DC voltage from the voltage multiplier is going to vary depending on the amount of ambient RF available in the surrounding. This varying voltage may sometimes be higher than the required voltage to charge the mobile phone. For this reason, a regulating circuit is essential to make sure the output to the load does not surpass the required voltage. Most phones require a voltage within a range of 4-5V, a 7805 voltage regulator was chosen for this study to stabilize the voltage at 5V. It is also important to control the amount of current that gets to the phone—a 3 $\Omega$  resistor is used for this purpose.

The battery bank to be charged is a collection of four lithium batteries, each with 3.7V connected in series. As one can easily guess, the output of this battery bank is above 4.5V ( $3.7V \times 4 = 14.8V$ , to be exact), which is the energy requirement of a mobile phone. A 7805 voltage regulator is used to step down the output of the battery bank to charge a mobile phone. For current control, a limiting resistor is also



used. The battery bank is connected to the RF energy harvester's output to charge it; when needed, these batteries can be used to charge mobile phones.

### 3.2.1 Stage Capacitance and Diode Selection

The stage capacitance is challenging to work with (see Figure 7) as the capacitance parameter is very sensitive, leading significant impact on the output voltage. The surface mount capacitors are used to make the board and overall system as small as possible. Each stage uses two capacitors, which are kept the same, but the change is made from one stage to the next. If the first stage uses 100pF capacitors, then the next stage would use 50pF. To halve the previous stage capacitor seemed reasonable mainly for ease of testing and the availability of parts. The charge in a capacitor can be express as:

$$Q = C * V(t) \tag{1}$$

In equation (1), the voltage in a capacitor is inversely proportional to the capacitance in relation to the charge.

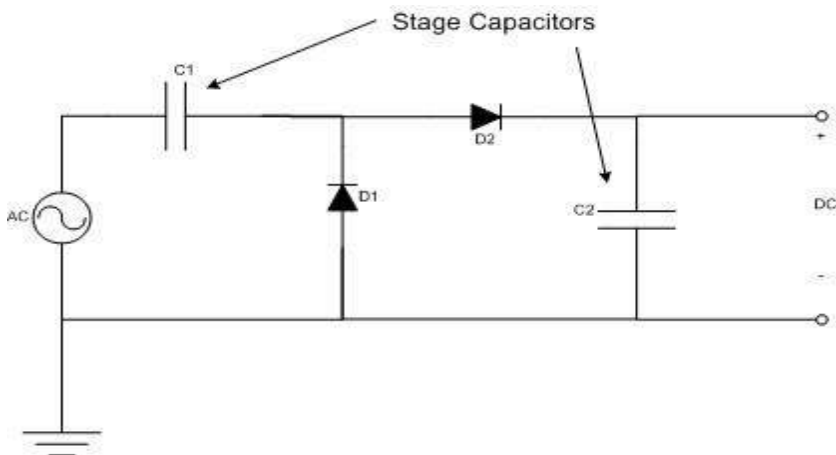
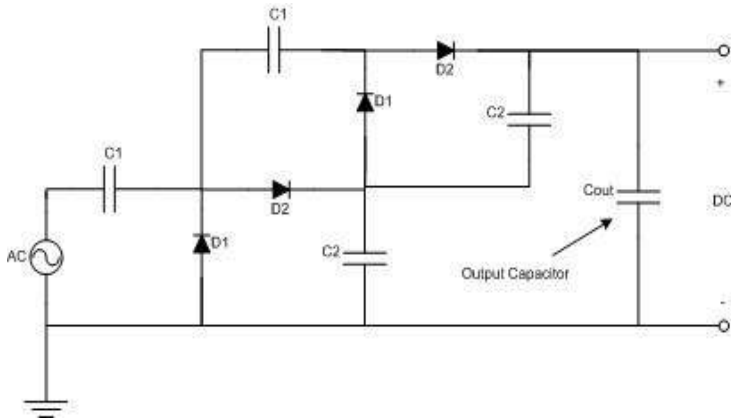

Fig. 7 Stage Capacitance

The variable that has the least effect on the overall system is the output capacitance, as shown in Figure 8. Generally, the value of this capacitor only affects the speed of the transient response. The bigger the value for the output capacitance, the slower the voltage rise time. This does not mean, however, that the smallest capacitor will work the best or that no capacitor should be used. Without a capacitor there, the output is not a good DC signal but more of an offset AC signal, meaning that it will be DC with ripple.



**Fig. 8 Output Capacitance**

One of the crucial requirements for the energy harvesting circuit is to operate with weak input RF power. For a typical  $50\text{-}\Omega$  antenna, the  $20\text{dBm}$  received RF signal power means an amplitude of  $32\text{mW}$ . As the peak voltage of the AC signal obtained at the antenna is generally much smaller than the diode threshold, diodes with the lowest possible turn-on voltage are preferable. Moreover, since the energy harvesting circuit operates at high frequencies, diodes with a very fast switching time need to be used. Schottky diodes use a metal-semiconductor junction instead of a semiconductor-semiconductor junction. This allows the junction to operate much faster, and gives a forward voltage drop of as low as  $0.15\text{ V}$ . For this study, the LN6810 Schottky diode was used, which has a forward voltage of around  $0.15\text{ V}$  at  $1\text{mA}$ .

## 4 Results and Discussion

Proteus simulation tool was used to simulate most parts of the system. The system's performance is also tested and evaluated, and the problems encountered during the system's development are presented. A digital multimeter was used to measure the components' individual performance and the system's overall output.

Given an input of  $0.9\text{V}$  at a frequency of  $900\text{MHz}$ , the doubler gave an output of  $3.5\text{V}$ . When the input was increased to  $1.2\text{V}$ , an output of  $7\text{-}8\text{V}$  was obtained. These simulation results are for an ideal situation, the drop-down voltage across the ten diodes used is not considered, and maximum power transfer is assumed between the antenna and the voltage doubler. The results obtained from the simulation with variation at the input is shown in Table 1. The variations in output with change at the input is shown in Figure 9.

**Table 1. Voltage Doubler Simulation Results**

S/N	Input Voltage (Vo)	Frequency (f)	Output Voltage(Vout)
1	0.9V	900MHz	3.5V
2	1.2V	900MHz	7.5V
3	1.5V	900MHz	9.5V
4	1.8V	900MHz	12.3V
5	2.1V	900MHz	15.1V

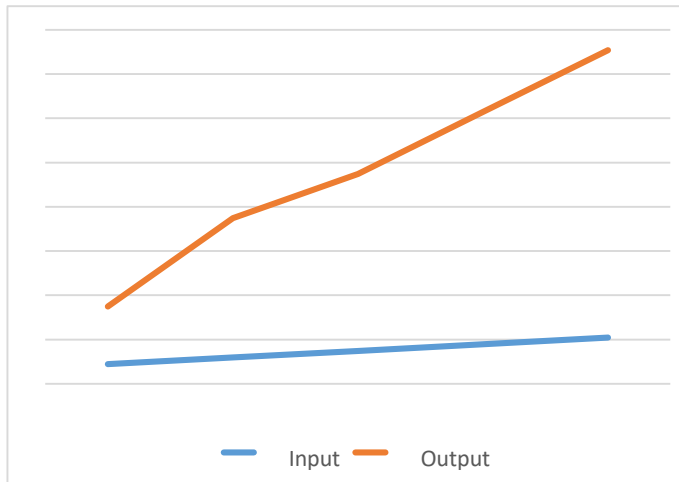

**Fig. 9 Graph Showing Variation in Output with Change at Doubler Input**

For the system's conversion efficiency, the increase obtained in the output (Pdc) given an input (Prf) is shown in Table 2.

**Table 2. Percentage Conversion Efficiency of the Developed System**

S/N	PRF (volts)	PDC (volts)	Efficiency (%)
1	0.57	0.91	59.65
2	0.46	0.78	69.56
3	0.52	0.87	67.31
4	0.54	0.89	64.81
5	0.47	0.77	63.83
6	0.51	0.79	54.90
7	0.49	0.79	61.22

Average conversion efficiency = 63.04%. This conversion efficiency is the increase obtained at the output, that is, each efficiency is an increase to 100% of the input. The variations in the harvested power and the DC output are as shown in

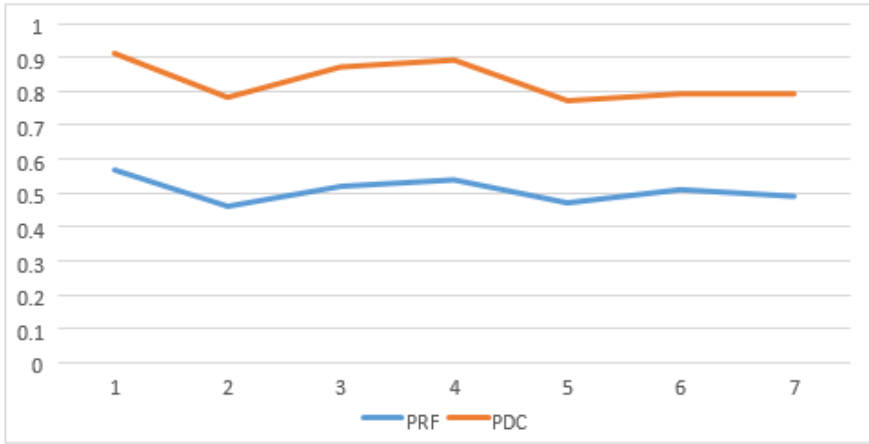

Fig. 10 Graph Showing Harvested Power and DC Power

For the charging efficiency of the system, the battery charging efficiency is described in Table 3.

Table 3. System's Charging Efficiency

S/N	Time (minutes)	Battery Capacity (volts)
1	0	2.17
2	30	2.85
3	60	3.51

Charging efficiency after 30mins of charging:

$$\frac{V_2 - V_1}{t_2 - t_1} = \frac{2.85 - 2.17}{30 - 0} = 0.0226V/min$$

Charging efficiency after another 30mins of charging:

$$\frac{V_2 - V_1}{t_2 - t_1} = \frac{3.51 - 2.85}{60 - 30} = 0.0220V/min$$

Average charging efficiency:

$$\frac{0.226 + 0.0220}{2} = 0.0223V/min$$

The charging efficiency of the system is as shown in Figure 11.

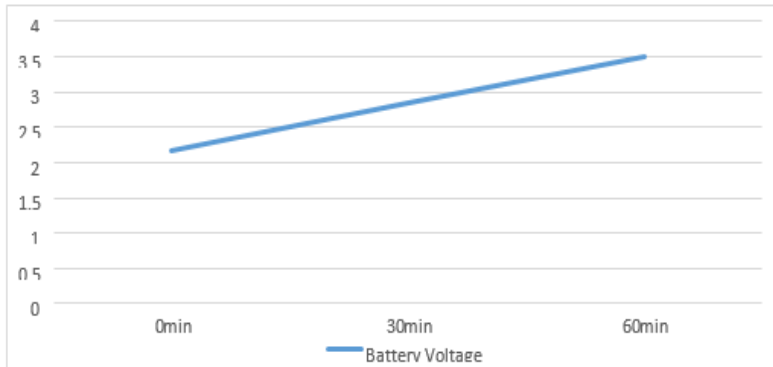

Fig. 11 Charging Efficiency of the System

The voltage doubler was tested after fabrication with a 4G LTE antenna with a power of 80dB. The doubler is a five-stage voltage doubler consisting of ten diodes and ten capacitors. An output voltage of around 700-900mV was realized at the output. The output voltage is relatively small because of the drop-down voltages incurred by the diodes. Each diode has a forward voltage of 0.15V; by multiplying this value by ten (number of diodes), it can be deduced that around 1.5V was lost within the circuitry. The diode series intended for this study was the HSMS 282x diodes, but because of their unavailability in the market, the LN6810 diode was used.

This research study is primarily empirical. There are many variables in the system that can change the voltage that is developed. The stage capacitors need to be optimized. The number of stages needs to be determined that, combined with the capacitor values for each stage, will result in a sufficiently high voltage level to turn on the phone and charge the phone's battery. Also, a capacitor can be used across the output as a filter to provide a flat DC signal and store charge. The value of that capacitance also needs to be determined. There are no fixed parameters for any of these values.

The major challenge encountered during this was the high efficiency of mobile phone antennas. The mobile network frequency is transmitted with a very low power compared to other frequency bands. This was a challenge because even though there is a mobile network signal, the power with which it is transmitted is low. Therefore, the energy that can be harnessed from it is relatively low.

## 5 Conclusion

A Radio Frequency Energy Harvesting (RFEH) system for charging mobile phones was successfully designed, developed, tested and evaluated. The presence of ambient radio frequency in the environment was explored, converting it into usable energy that can be used to charge our mobile phones. Although several works have been done on this subject, this work presented the use of a voltage doubler and battery storage for a more steady system. The energy stored in the batteries can later be used to charge a mobile phone. The system's conversion efficiency was evaluated to be 163.04%, and the charging efficiency was found to be 0.0223V/min. This work can be improved by the use of a more suitable diode and/or a dedicated RF source. A major challenge encountered is the mobile network's low power frequency transmission, resulting in a relatively low power harvest. For future works, a dedicated RF source can be developed to ensure the availability of sufficient RF at all times. Another issue to look at is the use of the HSMS 282x diode series, which has a very low voltage drop tending towards zero at 1mA.

## Acknowledgements

This work was supported by Institute of Information & communications Technology Planning & Evaluation (IITP) grant funded by the Korea government(MSIT) (2021-0-02068, Artificial Intelligence Innovation Hub).

## References

- [1] Bankmycell (2022) How many smartphone are in the world?. <https://www.bankmycell.com/blog/how-many-phones-are-in-the-world>. Accessed 27 March 2022
- [2] Yan H, Montero JM, Akhnoukh A, De Vreede LC, Burghartz J (2005) An integration scheme for RF power harvesting. In: Proceedings of STW annual work-shop on semiconductor advances for future electronics and sensors, Veldhoven, November 2005
- [3] Shinki Y, Shibata K, Mansour M, Kanaya H (2017) Impedance matching antenna-integrated high-efficiency energy harvesting circuit. *sensors* 17(8):1763
- [4] Adam I et al (2015) RF energy harvesting with efficient matching technique for low power level application. *ARNP Journal of Engineering and Applied Sciences* 10(18):8318-8321
- [5] Krishnachaitanya P, Pushpalatha A (2013) RF Energy Harvesting and Wireless Power Transfer. *International Journal of Electronics and Communication Engineering* 2(4):25-32

- [6] Schauwecker B (2016) Design of processing circuitry for an RF energy harvester. Dissertation, University of Arkansas
- [7] Hridayeta B, Singhal PJ (2015) RF Energy Harvesting from Cell Phone in GSM900 Band Int. Res. J. of Eng. Technol.(IRJET) 2:420-424
- [8] Narayana KL, Rajani P, Assistant S (2016) Design and simulation of rectenna for RF energy harvesting In: Proceedings of the national conference on computing, electrical, electronics and sustainable energy systems 2(1):21-26
- [9] Uzun Y (2015) Design of an efficient triple band RF energy harvester. The Applied Computational Electromagnetics Society Journal (ACES) 2015:1286-1293
- [10] Sivaramakrishnan A, Jegadishkumar KJ (2011) A highly efficient power management system for charging mobile phones using RF energy harvesting. International Journal of Information Technology Convergence and Services 1(5):21
- [11] Nintanavongsa P (2014) A survey on RF energy harvesting: circuits and protocols. Energy Procedia 56:414-422