



EFFECT OF CHEMICAL FERTILIZERS ON GROUNDWATER QUALITY IN AN UNCONFINED AQUIFER

A. R. Adesiji¹, O. D. Jimoh¹, P. A. Adeoye², A. J. Odofin³, O. E. Asogwa¹, J. A. Mangey⁴, and O. M. Odekunle⁵

¹Department of Civil Engineering, Federal University of Technology, Minna, Nigeria

²Department of Agriculture and Bioresources Engineering, Federal University of Technology, Minna, Nigeria

³Department of Soil Science and Land Management, Federal University of Technology, Minna, Nigeria

⁴Department of Water Resources and Environmental Engineering, Ahmadu Bello University, Zaria, Nigeria

⁵Department of Geography, Federal University of Technology, Minna, Nigeria

*Corresponding author's email address: ade.richard@futminna.edu.ng

ARTICLE INFORMATION

Submitted 29 Nov., 2022
Revised 14 January, 2023
Accepted 16 January, 2023

Keywords:

unconfined aquifer
Groundwater
Water Pollution
Nitrates
Fertilizers

ABSTRACT

The use of fertilizer on soil to improve agricultural yield has been practiced for years. While fertilizers and manures greatly improve crop yield, it is also important to consider their corresponding and devastating effects. In this study, the fertilizers application rate was varied and their effects on groundwater quality with soil depths of 30 cm and 60 cm were observed. Two fabricated lysimeters were used to collect soil samples undisturbed and taken to the laboratory for analyses. The samples in the lysimeters were made saturated and varying quantities of fertilizers from 87.37 g, 100 g. and 120 g were applied. The saturation of the samples was done through an improvised rainfall simulator which was set up in such a way that a constant discharge was adopted. Water samples were collected at 30 cm and 60 cm depths and analyzed for fertilizer residues and physico-chemical characteristics such as temperature, pH, total chloride, total dissolved solids, dissolved oxygen, conductivity, free ammonia, total phosphate, urea, zinc and iron were also analysed. The results showed that the more the quantities of fertilizers applied on the soil, the more it affects the physico-chemical properties of the water and renders it toxic and unsuitable for drinking purposes except treated. The results, however revealed that the concentrations of the fertilizers in the groundwater decreases with soil depths. It is therefore recommended that any groundwater being explored for domestic use close to soil surface in areas prone to fertilizer pollution should be well treated before consumption, most especially for people using shallow wells.

© 2023 Faculty of Engineering, University of Maiduguri, Nigeria. All rights reserved.

1.0 Introduction

Soil application of agro chemicals such as fertilizers plays a major role in enhancing the fertility of the soil for agricultural productivity in recent times. This, therefore, means the primary purpose of applying fertilizers to the soil is mainly to improve the crop yield in order to enhance profitability of the farming enterprise. But the adverse environmental effects of these chemicals on soil and groundwater body in the case of fertilizer overdose have been of serious concerns to the environmentalists. According to Kumar *et al.* (2019), changes from traditional agriculture practices to modern agriculture practices have led to the increase in the application of chemical fertilizers which, in turn, has resulted in higher groundwater contamination. Some fertilizers, such as nitrate, play a more important role in the contamination of water and soil due to their physical and chemical characteristics, especially in agricultural lands (Badrzadeh *et al.*, 2022). Therefore, what influences the mobility of these contaminants through soil to groundwater like soil, hydrogeological conditions, land use systems and climate differ from one location to another (Adeoye *et al.*, 2017). Collin and Melloul (2003)

also pointed out that this may be as a result of different soil and hydrogeological settings offering different vulnerability and different degrees of protection to the underlying aquifer. Rainfall influence on the contaminants transport cannot be overemphasized. According to Pérez *et al.* (2003), in regions with high rainfall, such with average precipitation of 700 mm/year, nitrogen-based fertilizer residues left unused by plants may be leached away thereby contaminating groundwater. The contamination may occur several days even months after the fertilizers have been spread. The rate at which the contamination occurs, according to Pérez *et al.* (2003), depends on the nitrogenous compound concentration in the unsaturated zone of the soil, on input from atmosphere and on the hydrology of the aquifer. The precipitation influence on the fertilizers leaching to the groundwater body has been corroborated by Gunatilake (2016). There has always been a link between fertilizers leaching (in areas with a dryer climate) and intensive irrigation as well (Djaman *et al.*, 2018).

The use of lysimeter to study migration of contaminants to groundwater has also been recognized for many years because it has been of major importance in the development of understanding of soil water and contaminants dynamics in the subsurface. Earliest lysimeter consisted of a container filled with soil repacked to a similar bulk density of that in the fields. Ehler and Goss (2003) and Goss *et al.* (2010) developed a non-weighing drainage lysimeters and tension lysimeter by placing a wick in contact with the soil body to carry water down into the collecting vessel. Goss and Ehlers (2009) developed a hybrid weighing lysimeter which allows the contaminant load entering unconfined shallow groundwater to be identified. Karthikeyan *et al.* (2008) studied the migration of faecal matter through soil with a drainage non-weighing lysimeters. The results from all these studies and more show fast movement of these bacteria as a result of very permeable nature of the vadose zone soil. The concentrations of these chemicals seem to be reducing as they move through the soil mass.

Several cases of water borne diseases have been documented in Minna over the years (Galadima *et al.*, 2011; Adeoye *et al.*, 2017; Ibrahim *et al.*, 2018; Yusuf 2021). Chukwu *et al.* (2004) reported nine years water borne diseases in Minna and also reported that major water borne diseases affecting Minna inhabitants are typhoid, diarrhea, cholera, amoebiasis and blue baby. It was concluded from his study that majority of people affected by these diseases are people living in the suburb and close to area where there are intensive farming activities like dairy, slaughters house and poultry activities. Some groundwater sampling campaign in North central Nigeria and Minna (Jimoh *et al.*, 2003; Salami *et al.*, 2008; Isikwue *et al.*, 2011) have reported presence of nitrates, phosphates and biological parameters especially inside the poultry farms as a result of indiscriminate dumping of poultry manure. However, a mechanism guiding the transport of the pollutants through the vadose zone into the groundwater has not been adequately studied. This work is therefore aimed at ascertaining the behaviour of chemical fertilizer contaminants through the soil profile to be able to predict and describe the danger posed to groundwater aquifers by continuous and excessive application of chemical fertilizer to agricultural lands. The main objective is to study the effects of groundwater pollution from fertilizer use with soil depth and to draw conclusions on how the quantities of fertilizer use affects groundwater bodies.

2. Methodology

2.1 Description of study area

The study area was an Inland Valley located between Latitude 9° 5000' and 9° 5625' N and Longitude 6° 373' and 6° 4375' E. The valley is located at the western end of Minna, a North-Western town in Niger State, Nigeria within the permanent site of Federal University of Technology, Minna. The catchment area of the basin is 30.79 km². The soil type on the study area was in a textural class of gravelly sand up to the depth of 80 - 90 cm. The area is characterized

with low and erratic rainfall of between 1000 to 1200 mm as total annual rainfall with peaks in July and August.

2.2 Experimental method and data collection

Two different agricultural zones within the study area were selected in this study. Lysimeters of 0.3m diameter and 1m length with openings for water collection at 30, 60 and 90 cm (Figure 1) were inserted into the soil at the locations in order to collect the soil samples undisturbed. The lysimeters were pushed into the soil profile with little disturbance to the soil mass. The lysimeters were extracted from the soil and transported to the laboratory for laboratory experimental set up. The hydraulic conductivity test was also carried out to study the permeability of the soil. This was done in the laboratory using falling head method. Soil samples for the permeability test were taken at the four different sampling points (Sites A, B, C, D) within the study area. At each of the sampling point, samples were taken at the different depths of 30 cm, 45 cm, 60 cm, 75 cm, 90 cm and 105 cm making the total of twenty-four (24) soil samples taken.

The two lysimeters were left for 2 weeks to allow for stabilization of soil mass inside the lysimeters before the experimental analysis (application of fertilizers). For the experimental analysis, the Nitrogen, Phosphorus and Potassium (NPK) fertilizer particles were applied at the rate of 5.74 kg/ha according to Matsumoto and Yamano (2011), prior to the application of water through the rainfall simulator. The rainfall intensity was simulated using an improvised rainfall simulator with constant discharge at the rate of 1 litre/m² = 1 mm of rainfall (FAO, 1986).

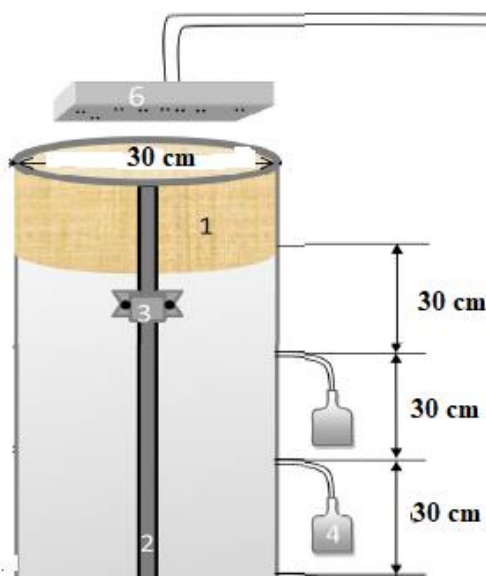

Figure 1: Lysimeter with the openings at different depths and rainfall simulator

The first experimental analysis (EXPERIMENT 1) started with the application of 87.37 g particles of NPK fertilizers (approximately at the rate of 5.74 kg/ha) on the lysimeters after which the water was then applied to them through rainfall simulator. At the end of rainfall simulation, water samples were collected using sterilized cans at the soil depths of 30 cm and 60 cm. The same procedures were repeated with the application of 100 g of NPK fertilizers on the soil columns in the lysimeters (EXPERIMENT 2). Water samples were also collected at the different depths of 30 cm and 60 cm. The collected samples were refrigerated and sent to the laboratory for further analysis. Analysis was carried out in the laboratory for the determination of the following parameters: pH, EC, TA, TH, CO₃²⁻, HCO₃⁻, Ca²⁺, Mg²⁺, Fe, Cl⁻, COD, NO₃⁻, PO₄³⁻.

3. Results and discussion

Table I shows the results of hydraulic conductivity from laboratory using Falling Head approach.

Table I: Hydraulic conductivity from Laboratory Method (Falling Head)

S/N	Sample ID	K (m/day)
1	A1 @ 30cm	3.51E-02
2	A1 @ 45cm	7.25E-02
3	A1 @ 60cm	3.27E-03
4	A1 @ 75cm	7.85E-04
5	A1 @ 90cm	7.56E-04
6	A1 @ 105cm	5.55E-04
7	B2 @ 30cm	1.31E-01
8	B2 @ 45cm	1.81E-01
9	B2 @ 60cm	2.25E-01
10	B2 @ 75cm	1.22E-01
11	B2 @ 90cm	2.05E-01
12	B2 @ 105cm	1.90E-01
13	C3 @ 30cm	4.66E-02
14	C3 @ 45cm	4.73E-02
15	C3 @ 60cm	8.99E-03
16	C3 @ 75cm	2.70E-01
17	C3 @ 90cm	1.17E-01
18	C3 @ 105cm	3.14E-02
19	D4 @ 30cm	1.72E-01
20	D4 @ 45cm	1.56E-01
21	D4 @ 60cm	5.60E-02
22	D4 @ 75cm	6.82E-02
23	D4 @ 90cm	1.74E-01
24	D4 @ 105cm	1.03E-01

The hydraulic conductivity from Table I ranged from 0.00054 – 0.265 m/day. The soil profile at the surface in all the sampled areas show low porosity with higher porosity observed at 90 to 105 cm, especially at Sites C and D.

The results of physico-chemical parameters of the water samples for EXPERIMENT 1 where 87.37 g of NPK fertilizers were applied on the first soil column is as presented in Table 2. Tables 2 and 3 show the results of water samples analysis collected at 30 cm and 60 cm soil depths. From the tables, it was observed that most of these parameters have their values reduced with depths. The same trend was observed in EXPERIMENT 2 (where 100 g of NPK fertilizers were applied on the second soil column). The results of the analysis for the EXPERIMENT 2 analysis were presented in Table 3.

Table 2: Results of Physico-chemical analysis of groundwater for EXPERIMENT 1

SAMPLE ID	pH	EC ($\mu\text{S/cm}$)	TA mg/l	TH mg/l	Ca mg/l	Mg mg/l	Cl mg/l	COD mg/l	HCO ₃ mg/l	CO ₃ mg/l	Fe mg/l	PO ₄ mg/l	NO ₃ mg/l
A1 30cm	7.6	1001	45	112	16.82	17.08	221	2460	20.61	19.38	7.5	6.78	5.22
A2 30cm	7.64	752	40	86	21.86	7.66	194	2384	18.04	16.95	6.38	6.87	4.85
A3 30cm	7.65	613	36	120	20.18	16.98	204	2077	15.97	15.02	6.75	7.03	5.5
A4 60cm	7.05	535	24	180	42.05	18.3	15.86	26.88	9.79	9.2	1.11	4.67	1.35
A5 60cm	7.08	472	24	176	31.95	23.47	13.55	29.25	9.79	9.2	1.38	2.31	1.51
A6 60cm	7.06	506	26	136	28.59	15.76	15.6	31.4	10.82	10.17	1.29	2.34	1.48

Table 2 shows that there is no significant variation in the pH values of the water samples collected at both depths. The pH values obtained at both depths range between 7.05 at 60 cm and 7.65 at 30 cm. However, the pH values at both depths were all within the permissible of 6 – 8 which is consistent with Jeyaruba and Thushyanthy (2009). The same trend was observed in EXPERIMENT 2 though with lower pH values which ranged from 6.66 at 60 cm depth to 6.87 at 30 cm depth. Interestingly, the highest nitrates and phosphates values were recorded at depths 30 cm compared to the values obtained at 60 cm. This could be attributed to the reduction in concentration of these particles as they migrate deeper into the soil mass. And it also means that fertilizer particles are being taken up in the soil mass as they move downward into the soil column. For nitrates, the values declined from 5.22 mg/L at 30 cm to 1.35 mg/L at 60 cm. The phosphate values recorded declined from 6.87 mg/L at 30 cm to 2.31 mg/L at 60 cm. The indication of this is that nitrates and phosphates contents of the applied NPK fertilizers could not leach up to a depth of 60 cm and beyond of the soil within the period of the study as they are being used up as they move downwards. The dynamics of nitrates and phosphates is consistent with findings of Holford and Doyle (1992) and Jung (2020). The same pattern was observed in EXPERIMENT 2 as phosphate and nitrate values declined from 30 cm depth to 60 cm depth. Nitrate values in EXPERIMENT 2 declined from 3.38 mg/L at 30 cm depth to 0.1 mg/L at 60 cm depth.

Table 3: Results of Physico-chemical analysis of groundwater for EXPERIMENT 2

SAMPLE ID	pH	EC ($\mu\text{S/cm}$)	TA mg/l	TH mg/l	Ca mg/l	Mg mg/l	Cl mg/l	COD mg/l	HCO ₃ mg/l	CO ₃ mg/l	Fe mg/l	PO ₄ mg/l	NO ₃ mg/l
B1 30cm	6.87	4100	50	132	28.59	16.83	185.22	3700	28.35	11.14	6.25	6.35	3.38
B2 30cm	6.77	3960	60	168	26.07	24.08	196	3600	20.1	12.11	6.3	6.6	3.5
B3 30cm	6.78	4360	65	164	40.37	29.76	162.68	3400	9.79	9.2	6.27	6.47	1.94
B4 60cm	6.83	549	45	100	25.23	6.97	196	1350	11.85	26.64	3.5	3.65	0.15
B5 60cm	6.78	706	44	94	27.75	7.05	140.14	1200	12.88	18.89	1.75	3.4	0.1
B6 60cm	6.66	459	30	98	16.82	7.01	123.48	1275	12.88	12.11	4	3.75	0.15

The electrical conductivity EC values followed a declining pattern as the fertilizer particles migrate down into the soil mass. From Table 2, the highest value recorded was 1001 $\mu\text{S/cm}$ at 30 cm soil depth compared to the lowest of 472 $\mu\text{S/cm}$ at 60 cm soil depth. The higher values of electrical conductivity observed at the surface (30 cm) as impacted by fertilizer addition might be due to the amount of dissolved salts in the fertilizer which decreased as it moved downwards (Ozlu and Kumar, 2018).

The same trend was observed in EXPERIMENT 2, though with higher values of EC, which could be as a result of higher quantity of NPK fertilizers applied. The value recorded was as high as

4100 $\mu\text{S}/\text{cm}$ at 30 cm depth compared to 459 $\mu\text{S}/\text{cm}$ obtained at 60 cm. Electrical conductivity has been explained (Mkandawire, 2008) as an indication of dissolved elements (metallic and non-metallic) in water and the increase in values may be attributed to the fact that infiltrating rain that was simulated on the soil core and applied poultry waste might have dissolved some organic and inorganic constituent of poultry waste which are capable of raising EC values of the water samples (Adeoye *et al.*, 2017). The total alkalinity obtained in the two experimental set up showed that the total alkalinity (TA) varied between 65 mg/L at 30 cm in EXPERIMENT 2 to 24 mg/L at 60 cm in EXPERIMENT 1. The values of TA fall within the allowable limit for TA in drinking water which is 20 – 200 mg/L.

4. Conclusion

The Effect of chemical fertilizers on groundwater quality in an unconfined aquifer has been studied. This study has shown that the soil on the experimental plots have ability to take in fertilizer particles as they migrate deep down into the soil mass. Nitrates and phosphates generally decline in concentrations as they move with soil depths. They were able to leach up to 60 cm of soil depth of the undisturbed soil columns. These observations were attributed to high porosity of the soil and high hydraulic conductivity which ranged from 0.00054 – 0.265 m/day according to hydraulic parameters analysis carried out on the soil of the area. The results obtained in this study can be used as baseline to know the precise application of fertilizers needed for optimum crop productivity with little negative effects on human consumption of groundwater bodies. The results of this study can also help in modelling the fertilizers particles movement in the soil columns. This information from this study can also be used as input parameters into modern software and models for predicting contaminant fate, transport and persistence in unconfined aquifer.

Acknowledgements

This study was funded by Tertiary Education Trust Fund (TETFund) through Institution Based Research (IBRI) Grant. The supports of laboratory staff of the departments of Civil Engineering and Water Resources Aquaculture and Fisheries Technology (WAFT), Federal University of Technology, Minna, Nigeria for the scientific and laboratory analyses are well acknowledged.

References

- Adeoye, PA., Man, HC., Soom, MA., Thamer, AM. and Oluwakunmi, AC. 2017. Contaminants leaching from fresh poultry waste: a lysimeter study on sandy soils under tropical conditions. *Environment and Pollution*, 6(1): 38-51.
- Badrzadeh, N., Samani, JMV., Mazaheri, M. and Kuriqi, A. 2022. Evaluation of management practices on agricultural nonpoint source pollution discharges into the rivers under climate change effects. *Science of The Total Environment*, 838: 156643.
- Chukwu, P., Ejeji, CY. and Alonge, FS. 2004. Appraisal of prevalence of water-borne and water-based diseases in selected cities of north central Nigeria. *Nigerian Journal of Technological Development*. 8(2): 209.
- Collin, ML. and Melloul, AJ. 2003. Assessing groundwater vulnerability to pollution to promote sustainable urban and rural development. *Journal of Cleaner Production*, 11(7): 727-736.
- Djaman, K., Mel, VC., Diop, L., Sow, A., El-Namaky, R., Manneh, B., Saito, K., Futakuchi, K. and Irmak, S. 2018. Effects of alternate wetting and drying irrigation regime and nitrogen fertilizer on yield and nitrogen use efficiency of irrigated rice in the Sahel. *Water*, 10(6): 711.

Ehlers, W. and Goss, M. 2003. The role of water in plant life. Water dynamics in plant production, Wallingford UK: CABI Publishing, 1-9.

FAO. 1986. Irrigation Water Management. Food and Agricultural Organization (FAO) Training Manual. FAO, Rome, 235.

Galadima, A., Garba, ZN., Leke, L., Almustapha, MN., and Adam, IK. 2011. Domestic water pollution among local communities in Nigeria-causes and consequences. European Journal of Scientific Research, 52(4): 592-603.

Goss, MJ. and Ehlers, W. 2009. The role of lysimeters in the development of our understanding of soil water and nutrient dynamics in ecosystems. Soil Use and Management, 25(3): 213-223.

Goss, MJ. Ehlers, W. and Unc, A. 2010. The role of lysimeters in the development of our understanding of processes in the vadose zone relevant to contamination of groundwater aquifers. Physics and Chemistry of the Earth, Parts A/B/C, 35(15-18): 913-926.

Gunatilake, SK. 2016. N and P variation in groundwater in wet zone and dry zone in Sri Lanka due to fertilization of paddy crop. International Journal of Scientific Research Publications, 6(9): 1-5.

Holford, ICR. and Doyle, AD. 1992. Yield responses and nitrogen fertilizer requirements of wheat in relation to soil nitrate levels at various depths. Soil Research, 30(5): 683-694.

Ibrahim, S., and Ahmad Sabri, AZS. 2018. Informative water supply challenges on the development of towns: a study of Minna town central Nigeria. Voice of Academia (VOA), 13(1): 1-8.

Isikwue, MO., Iorver, D. and Onoja, SB. 2011. Effect of depth on microbial pollution of shallow wells in MakurdiMetropoilis, Benue State, Nigeria. British Journal of Environment and Climate Change, 1(3): 66-73.

Jeyaruba, T. and Thushyanthy, M. 2009. The effect of agriculture on quality of groundwater: A case study. Middle-East Journal of Scientific Research, 4 (2): 110-114.

Jimoh, OD., Ayodeji, MA. and Mohammed, B. 2003. Effect of agro-chemicals on surface and ground waters in Tunga-Kawo (Nigeria) irrigation scheme. Hydrological Science Journal, 48(6): 1013-1023. <https://doi.org/10.1623/hysj.48.6.1013.51426>

Jung, HB. 2020. Geochemical and hydrological study of coastal groundwater discharging to an urban estuary in northern New Jersey. Environmental Earth Sciences, 79(6): 1-14.

Karthikeyan, OP., Murugesan, S., Joseph, K. and Nagendran, R. 2008. Leaching of inorganic pollutants from fresh and partially degraded Municipal Solid Waste: a lysimeter study under tropical conditions. International Journal of Environment and Waste Management, 2(1-2): 49-64.

Kumar, R., Kumar, R. and Prakash, O. 2019. Chapter-5 the Impact of Chemical Fertilizers on Our Environment and Ecosystem. Research Trends in Environmental Sciences, 35, 69-85.

Matsumoto, T. and Yamano, T. 2011. Optimal fertilizer use on maize production in East Africa. In Emerging Development of Agriculture in East Africa: Markets, soil, and innovations, Springer, Dordrecht, pp 117-132.

Mkandawire, T. 2008. Quality of groundwater from shallow wells of selected villages in Blantyre District, Malawi. Physics and Chemistry of the Earth, Parts A/B/C, 33(8-13): 807-811.

Ozlu, E. and Kumar, S. 2018. Response of soil organic carbon, pH, electrical conductivity, and water stable aggregates to long-term annual manure and inorganic fertilizer. *Soil Science Society of America Journal*, 82(5): 1243-1251.

Pérez, CA., Armesto, JJ., Torrealba, C. and Carmona, MR. 2003. Litterfall dynamics and nitrogen use efficiency in two evergreen temperate rainforests of southern Chile. *Austral Ecology*, 28(6): 591-600.

Salami, BF., Oladiran, FB. and Jayeola, SO. 2008. Assessment of shallow groundwater quality around Minna abattoir and central market. *African Journal of Environmental Science and Technology*, 11(6): 313-325

GALLEY PROOF