

**DESIGN AND CONSTRUCTION OF A  
1KVA (AVR) WITH DIGITAL DISPLAY AT  
THE OUTPUT.**

BY

**IKOGOR LIFFUSON JOSEPHS**

**2000/9847EE.**

DEPARTMENT OF

ELECTRICAL AND COMPUTER ENGINEERING, FEDERAL

UNIVERSITY OF TECHNOLOGY

MINNA

OCTOBER 2006.

DESIGN AND CONSTRUCTION OF A  
1KVA (AVR) WITH DIGITAL DISPLAY  
AT THE OUTPUT.

BY

IKOGOR LIFFUSON JOSEPHSS

2000/9847EE

A THESIS SUBMITTED TO THE DEPARTMENT OF ELECTRICAL AND  
COMPUTER ENGINEERING,  
SCHOOL OF ENGINEERING AND ENGINEERING TECHNOLOGY  
FEDERAL UNIVERSITY OF TECHNOLOGY, MINNA.

**OCTOBER 2006.**

## DEDICATIONS

This project is dedicated to the ALMIGHTY GOD; the Great I AM whose faithfulness and love endures forever. To the loving memory of my late father, Mr. Christopher Ikogor whose love and supports goes beyond description, I will always miss you. To my dearest mother Mrs. Lucy O. Ikogor for all her supports, encouragement and care. MAMA you are the greatest! You are highly appreciated and my siblings, you are all wonderful.

## DECLARATION

I, IKOGOR L. JOSEPHS declare that this work was done by me and has never been presented elsewhere for the award of a degree. I also hereby relinquish the copyright to the Federal University of Technology, Minna.

IKOGOR L. JOSEPHS.....

(Name of student)

 10/10/08

(Signature and Date)

...MRS .CALENOGHENA.....

(Name of Supervisor)

 11/10/08

(Signature and Date)

Engr. M.D. ABDULLAHI.....

(Name of H.O.D)

.....

(Signature and Date)

.....

(Name of External Examiner)

.....

(Signature and Date)

## ACKNOWLEDGEMENT

My unreserved acknowledgement and appreciations goes to my project supervisor, Mrs. Caroline Alenoghena for time despite her tight schedule, for her encouragement even while it proved difficult securing a project topic, for her moral supports whenever challenges arrives and more so for her kind words, your labor of love will never go unrewarded.

My profound appreciated and acknowledgement also goes to the entire members of staff, Department of Electrical and Computer Engineering, FUT MX; to the H.O.D. Engr. Musa Abdullahi, Engr. Dr. Y.A Adediran (Asso. Prof), Dr. Ms. E.N. Onwuka the project coordinator, Engr. M.S. Ahmed, Mr. J.G. Kolo, and Mr. S.N. Rumala and to staff whose names are not measured

My acknowledgement also goes to my parents Mr. and Mrs. Christopher Ikogor, I love you both and I say "thank you for everything". to my siblings; Emmanuel, Patience, Victoria, Eunice and Mercy. To my lovely twins' niece and nephew; Blaise and Agatha, you guys are the bomb, thanks for believing in me.

I will never forget to acknowledge Engr. Agocha Paul for all his effort towards making this project a reality and for all his supports "you are friend in deed", what will I have done without you?. To all my friends; Avong, Ogijo Samuel, Ogar Peter, Innocent Unaji, Ogar Emmanuel, Helen and all the inhabitants of Mount 'Olives (Blessed zone).

To my Grandma, Suleiman and to all those who have contributed to the success of this project.

## ABSTRACT

The design of an AUTOMATIC VOLTAGE REGULATOR WITH DIGITAL DISPLAY AT THE OUTPUT is simple and precise, serves as a means of safe-guarding electronic devices that are sensitive to voltage fluctuations and thus gives a constant output of 220v regardless of variation in input voltages. The desired constant output of 220v was accomplished through the use of Auto-transformer whose tapping provided the different voltage levels at the input and a 12v a.c which was rectified to 12v d.c to power the circuit. A quad-IC LM324 compares the variation at the input voltage supply. The output of the comparator controls the switching circuit; transistors and relays. The relay contacts opens and closes in relation to the sensed input and switches to the constant output of 220v.the digital display at the output was accomplished via the use of the delay IC 555 timer whose output triggers the logic IC whose output controls the display of the common anode configuration of the seven segment display of 220v output.

The circuit was designed and constructed, and upon testing at various input voltages a constant 220v was displayed.

## TABLE OF CONTENT

Title Page.....	
Dedication.....	i
Declaration.....	ii
Acknowledgement.....	iii
Abstract.....	iv
Chapter One.....	1
1.0 Introduction.....	1-3
1.1 Objective.....	3
1.2 Motivation.....	3
1.3 Methodology.....	4
1.4 Project Outline.....	4
<b>Chapter Two.....</b>	<b>5</b>
2.0 Literature Review.....	5-8
2.1 Principles of Operation.....	8
2.2 Theory of Operations.....	9-11
2.3 Block Diagram Of Project.....	11
Chapter Three: Design and Implementation.....	12
3.1 Power Supply Unit.....	12
3.2 Rectification and Filtering circuit.....	12
3.3 Smoothing Network.....	13-15

3.4 Regulation.....	15
3.5.0 Comparator circuit Design.....	15
3.5.1 Sensing circuit.....	15-18
3.6.0 Switching Circuit.....	19-20
3.7 Relay Circuit.....	21
3.8.0 Delay circuit Design.....	21-22
3.8.1 Monostable Operation.....	22
3.8.2 Power ON Reset or Trigger.....	22
3.8.3 Edge-Triggering g.....	22-23
3.9.0 Logic Circuit Design.....	23
3.9.1 The S-R Latch.....	23-24
3.10. Seven Segment Display Circuit.....	24-25
3.11 Design Of 1KVA Auto-Transformer.....	25-29
Chapter Four: Construction, Testing and Discussion of Results.....	30
4.0 Bill of Engineering Measurements and Evaluation.....	30
4.1 Construction;.....	31-33
4.2 Testing.....	33
4.3 Results.....	33
Chapter Five.....	34
5.1 Conclusion.....	34
5.2 Recommendation.....	34
References:.....	35



# CHAPTER ONE

## 1.0 INTRODUCTION

“Necessity is the mother of all inventions”. For most electrical devices to perform to its optimal capacity, the need for steady power supply cannot be over-emphasized. Power supply for electronic circuits is most conveniently obtained from commercial a.c lines by using rectifiers –filter system known as a d.c power supply.

The rectifier-filter combination constitutes an ordinary d.c power supply. The d.c voltage from an ordinary power supply remains constant so long as a.c mains voltage or load is unaltered .However, in many electronic applications, it is desired that d.c voltage should remain constant irrespective of changes in a.c mains or load. Under such situations, voltage regulating devices are used with ordinary power supply. This constitutes regulated d.c power supply and keeps the d.c voltage at fairly constant value.

The institution of Electrical Engineers IEE Regulations stipulates that for safe utilization of electrical energy, the fluctuations in nominal supply voltage at any time must not exceed  $\pm 6\%$ .The inconsistency in supply voltage falling below 190V or rising above 250V, representing a fluctuations of about 20% which is highly inimical to many voltage sensitive devices that tolerate a little degree of supply voltage fluctuation to function maximally. Under-voltage or over-voltage puts severe stress on electronic components. The effect accelerates the conditions under which a device gradually weakens, becomes marginal and finally wears out.

Untold damages results in all electronic and electrical appliances as well as devices such as computer systems, printers, scanners etc are mostly affected by over-voltage situation.

Similarly, motor driven equipment that required high current are hampered by under-voltage such loads includes air-conditioners factory driven plants, refrigerators etc.

In order to prevent the havoc occasioned by frequent fluctuations in our power supply, the need for automatic voltage regulator (AVR) is pertinent in order to sustain the durability and reliability of electrical and electronic devices to a predesigned specification i.e to maintain the output voltage steady at 220V.

The automatic voltage regulator is a short cut to stable power supply. The under-voltage and over-voltage protection are both achieved by suitably biased transistors as the case arises.

Rapid fluctuations seriously shorten the useful lifespan of all electrical and electronic equipment.

An automatic voltage regulator monitors the input voltage, then switches the output of the device to the transformer tap that gives a constant 220v output with no need for external agent. Thus, the undesired voltages as a result of over-voltage or under-voltage at the input of the regulator is controlled to a safe voltage level of 220v,

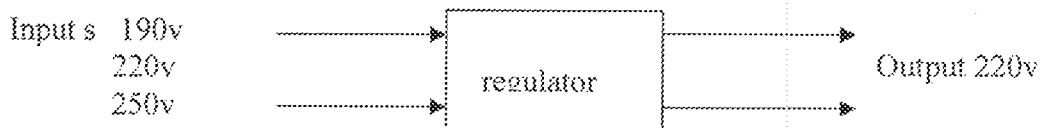

Fig 1. Block representation of an Automatic Voltage Regulation.

Automatic voltage regulator provides protection from under-voltage, surges, lightening and all forms of voltage fluctuations. Automatic voltage regulations are most useful in this part of the continent (Africa).

Automatic voltage regulator provides protection from under-voltage, surges, lightening and all forms of voltage fluctuations. Automatic voltage regulations are most useful in this part of the world.

AVR is used to regulate the input voltage of life-supporting machines, in homes and offices. The incorporation of the digital display at the output is to enhance precisions and accuracy at the output voltage of  $220\pm 5$  constantly.

## **1.1 OBJECTIVES**

The objectives of this project are to provide a regulated voltage supply to electronic devices and appliances at the required rate without fluctuations and a means to guide against surges.

The digital display at the output is to ensure accuracy and precision at the standard 220V a.c. that required for most appliances.

## **1.2 MOTIVATION**

In an ordinary power supply, the voltage regulation is poor. I.e., d.c output voltage change appreciably with load current. Moreover, output voltage also changes due to variations in the input a.c voltage. This is due to the following:

In practice, there are considerable variations in a.c line voltage caused by outside factors beyond our control; this changes the d.c output voltage of most electronic circuits. Electronic circuits will refuse to work satisfactorily on such output voltage fluctuation; this necessitates the use of regulated power supplies. [1]

This project is born-out of the need for steady power supply to electronic and electrical devices and to equally serve as a guide against damages to electronic circuitry due to incessant power fluctuations as well as outages which are not healthy to computers, hospital equipment that requires steady supply.

### **1.3 METHODOLOGY**

The construction of AVR with digital display at the output terminal requires an auto-transformer which provides the unregulated voltage supply and under the switching of relays (3) in conjunction with (2) transistors to give the regulated standard 220V at the output. The digital display was achieved via the use of delay (timer) and the logic IC which serves as a quad-latch.

### **1.4 PROJECT OUTLINE**

The project is made up of five chapters, of which chapter one is the introduction, chapter two comprises the literature review as well as the historical background, the block diagram and theory of operation of the circuit. Chapter three is the design procedures and analysis of the project. While chapter four contains the construction, testing and discussion of the results. Chapter five includes; the conclusion, the recommendation and the references.

## CHAPTER TWO

### 2.0 LITERATURE REVIEW:

The location of electric power generating station in distant areas from the consumers made the problem of voltage regulation more common. Thus, years of study and researching by great minds has revolutionized the development of transformer. Some years back George Westing House introduced the A.c transformer to help tackle the problem of power outages, voltage drops and electrical storms, surges etc.

Through A.c transmission and distribution, alternating voltage can be increased or decreased depending on the mode of operations. In Nigeria for instance, about 11KV is generated from the hydro-station which is then step-up to higher voltages of 132KV by transformer and later step-down to the required machines and all sorts of appliances.

The first attempt to obtain a good automatic voltage regulator employed a motorized system controlled by a control circuit to change the taps on the secondary of an auto-transformer in order to step-up when the input is low or step-down when the voltage input is high.

The motorized technique encountered some shortcomings and upheaval which includes it ease to weaken and wear-off due to the tap changing mechanism that is purely mechanical in operation, it was not cost-effective and above all it was bulky, (improper contacts between changer and taps).

Another notable approach that was introduced was the resonant-circuit voltage regulator which involved a few components such as inductance of a transformer, coupled with a parallel inductance and capacitive resonant when the line voltage is below the

rated value, less current is drawn by the inductance and the parallel circuit becomes capacitive.

The capacitive current drawn through the transformer raises the output voltage if the line voltage rises above the rated value, the parallel circuit combination becomes less capacitive and the output falls below the line voltage.

Its demerits were; its performance is frequency dependent; it was bulky and was later replaced by the regulated d.c inversion automatic voltage regulator.

Further research led to the regulated d.c output from the power supply is inverted using push-pull inversion. The principle of switch-mode power supplies is applied. It is then stepped-up to the required constant a.c output voltage using a transformer. The output of the system is a square wave a.c voltage which is filtered to obtain a pure sinusoid. This method resulted in very good regulation. The system is not heavy but very expensive and its complexity surpasses the rest approaches towards attaining automatic voltage regulator.

The phase controlled automatic voltage regulator replaced the regulated d.c inversion automatic voltage regulator. In this system, the load is connected in series with the voltage controlling device which is usually silicon control rectifier (SCR). Voltage control is achieved by triggering the silicon control rectifier at a phase angle as determined by the control circuit in such a way that the voltage across the load connected to the output terminals is regulated to the desired value.

This approach responds fast to voltage fluctuations at the output. This approach is not expensive and not heavy but the output voltage waveform is usually distorted.

The advancement in technology has led to the introduction of the transistorized automatic voltage regulator. It resulted from the reviewing of the motorized AVR. The target was to reduce the bulkiness and improve the response time of the regulator. The pure mechanical tap changer in the motorized AVR was replaced by a miniature electromechanical relays as the tap changer and the transistorized control circuit help to achieve the target. The system use high voltage relay to switch between the taps on the high voltage side of the secondary of the transformer, and the low-voltage relay to switch between the taps on the low supply voltage of the transformer. There is a control circuit which determines whether the low supply voltage is to be stepped-up to the rated value or the high supply voltage stepped-down to the rated value of the output. The current drawn is detected by the load and the position of the relay contacts on the tap of the transformer is detected by the control circuit. It has a reduced size and lighter but it short-comings includes a fairly good percentage regulation,

#### **IC APPROACH:**

In the early 1960s a new field of micro-electronics was born primarily to meet the requirements of the military which wanted smaller sizes of their electronic equipment to one-tenth. The led to the development of micro-electronic circuits known as integrated circuits (IC) which are pretty small in sizes.

J.S Kilby was the first to develop and IC in 1958, a single monolithic silicon chip in which active and passive elements were fabricated by successive diffusions and depositions. He was followed by Robert Noyce who successively fabricated a complete IC including the interconnections in a single silicon chip.

The merit of the IC approach includes;

- better response time, extreme reliability, low power consumption i.e low voltage and current consumption, sensitivity to voltage fluctuations, reduced size, light weight, cost effective and spare-parts availability etc.

for this design IC used includes; LM324, NE555 Timer, Logic IC 742LS79.

## **2.1 PRINCIPLES OF OPERATION (AVR).**

An AVR consists of two units: monitoring unit and the regulating unit.

The monitoring unit performs the following functions;

1. it detects and measures the change in the input voltage of the regulator.
2. It produces a signal to operate the switching unit.

the switching unit receives signal from the measuring unit and acts to correct the output voltage of the regulator to a constant predetermined value with least possible variation.

Sometimes, a third unit called anti-hunting unit is also used to provide smooth regulation without hunting or continual fluctuations.

In a true AVR, the two basic units namely the monitoring unit and the switching units can be separately identified. In many circuits however, the two units cannot be distinguished. These simpler units are usually called voltage stabilizers. This constitutes another significant difference between automatic voltage stabilizers. These voltage stabilizers find intensive use in electronic devices in spite of the fact that the accuracy of stabilization obtained is usually poor. [4]



## 2.2 THEORY OF OPERATIONS

When the circuit is connected to the mains supplying about 240V, the voltage is reduced or step-down by the auto-transformer rated at 12V (rms), this voltage from the auto-transformer is rectified by the full-bridge rectifier. The rectified output voltage is filtered by a capacitor C1 to remove ripples from it and it is passed through the regulating circuit consisting of a zener diode which set the reference voltage at 6.2v d.c another capacitor C2 is connected across the zener diode to further remove the existing ripples that have escaped from the filtering section of the circuit.

The comparator section is made up of a quad IC LM324 functioning as comparators one for sensing high voltage and the other for sensing low voltages. A step- down unregulated d.c voltage is applied to the non-inverting positive (+ve) input of the comparator1 for sensing high level above 220V and a reference voltage corresponding to the normal voltage is fed into the inverting (-ve ) input of the op-amp. The unregulated power supply is fed into non-inverting input of the comparator 2 while the reference voltage is applied to its inverting input for sensing voltage level below 220V. The switching circuit is the main control unit for the device while the voltage levels serve as the control signal for triggering as well as controlling the transistor switching and, relays which in turn is connected to the delay circuit as well as the logic circuit to the display circuit.

There are three main conditions for the operations of the switching circuit.They are:

1. When the supply voltage rises above 220V
2. When the supply voltage is normal at 220V

There are three main conditions for the operations of the switching circuit. They are;

1. When the supply voltage rises above 220V
2. When the supply voltage is normal at 220V
3. When the supply voltage is below 220V

When the mains supply voltage rises above 220V, the change in the voltage is reflected by the variable resistor  $V_{R1}$  ( $V_{in1}$ ). The comparator 1 compares the voltages at the inputs,  $V_{R1}$  and the fixed reference voltage  $V_{ref}$  at the cathode of zener diode.

Since the reference voltage is highly potential that is positive (+ve) with respect to the reflected voltage sensed by  $V_{R1}$ , the output of comparator 1 logically swings the output to the negative rail of the comparator. Comparator 1 is configured in inverting mode this make the output inverted to the positive rail and the base of transistor  $T_{R1}$  will be at higher potential causing the emitter-base region to be forward biased, the collector current flows to activate relay  $RL1$  and the normally open contact of the relay closes to the voltage level approximately 220V, under the same condition the output of comparator<sub>2</sub> falls low since its inverting input  $V_{ref}$  is greater than  $V_{in2}$ . However, there is a limited current to turn  $T_{R2}$  into operation hence relay coil  $RL_2$  remains in its de-energized condition until when another condition emerges.

When there is a supply voltage of 220V, there will be no current flowing to the base of the transistors  $T_{R1}$  and  $T_{R2}$  which implies that both transistors will remain in their cut-off states and the relays are not energized.

### 2.3 BLOCK DIAGRAM OF THE CIRCUIT

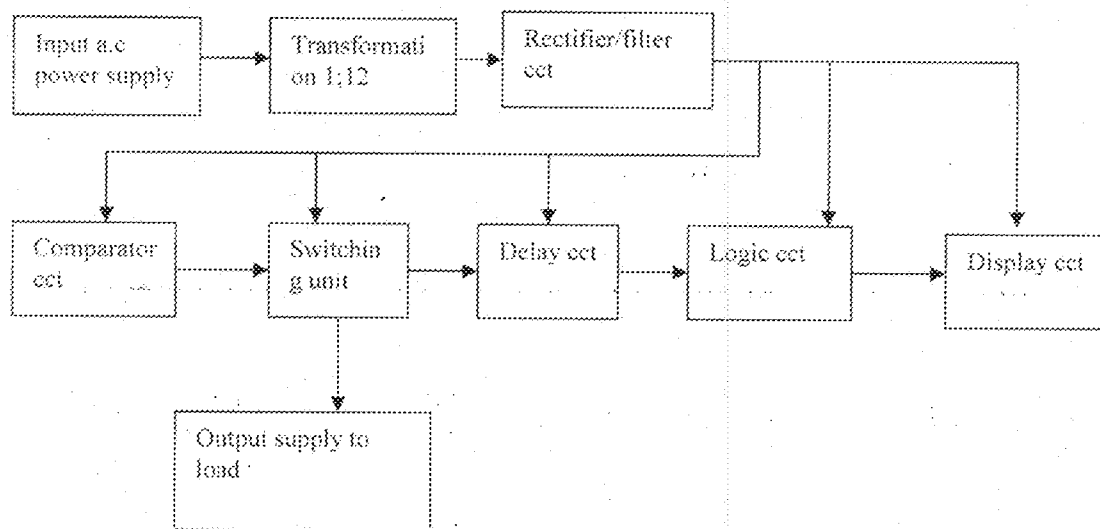

FIG.2 Block Diagram

## CHAPTER THREE

### 3.0 DESIGN AND IMPLEMENTATION

#### 3.1 THE SUPPLY UNITS DESIGN.

Electronics circuit needs power to work. In most case the energy is provided by a circuit called the power supply. A power supply failure will affect all of the other circuits. The supply is the key part of any electronics system. Power supply use rectifier diodes to convert alternating current to direct current (d.c).

In this design bridge rectifier was used. This circuit achieves full wave rectification without the use of center-taped transformer. It employ the use of four diodes (4) connected in an arrangement that looks similar to a Wheatstone bridge circuit. The cathode lead is from  $D_1$  and  $D_3$  are connected to form the positive output terminal of the circuit while the anode lead of  $D_2$  and  $D_4$  are connected together to form negative output of the circuit.[1]

#### 3.2 RECTIFICATION AND SMOOTHING CIRCUIT.

The unregulated d.c power supply contains a rectifier and a filter circuit. A rectifier must be able to pass current with ease into the forward direction and block its flow in the reverse direction. The variable a.c voltage is rectified through a rectifier circuit using a full wave bridge rectifier as shown below.

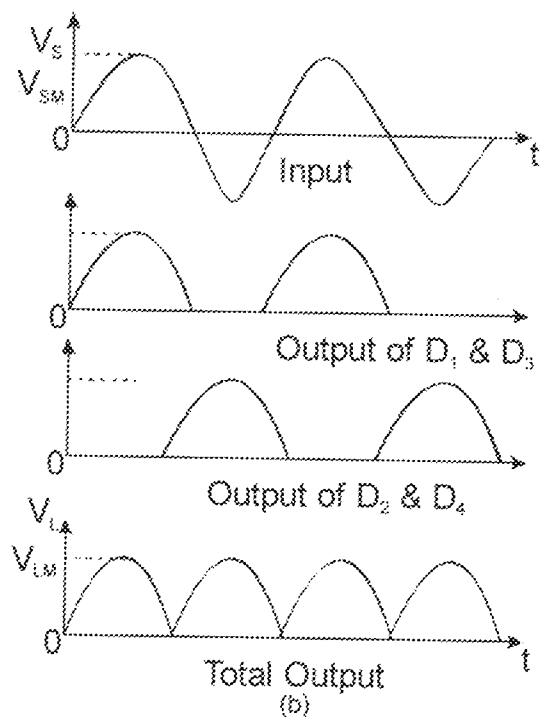

FIG.2 FULL WAVE BRIDGE RECTIFIER

#### DESIGN SPECIFICATION.

composition	Type	Part number	Usage	Max. Operation current. And reverse voltage.
Diode	Silicon	IN4001	Rectification	1A, 50V

### 3.3 SMOOTHING OR FILTER NETWORK

The output of the full-wave bridge rectifier is a pulsating voltage. In order to reduce the pulsations, a filter network is used. This is made up of a single electrolytic capacitor (1000 $\mu$ f) connected across the load terminals. This capacitor is chosen large enough to provide acceptable low ripple voltage, with voltage rating sufficient to handle the worst case combination of no load and high line voltage.

enough to provide acceptable low ripple voltage, with voltage rating sufficient to handle the worst case combination of no load and high line voltage.

Pulsating d.c is not pure because it contains an a.c component. The a.c component in a d.c power supply is called "RIPPLE".

Filter is used to remove ripple thus producing a smooth waveform that will approach that produced by a battery, by connecting capacitor across the output.

Capacitors are energy storage devices; they can take a charge and then later deliver that charge to a load. [2]

The capacitor operates in a simple fashion during the input cycle, the capacitor charges to the peak applied voltage when the voltage drops; the capacitor is discharged through the load. Since electrolytic capacitor is used, it will charge quickly when the diodes are forward biased, and discharge through the load slowly, the voltage is nearly a steady voltage but with variation called "RIPPLE".

The effectiveness of a capacitor filter is determined by;

1. The size of the capacitor
2. The value of the load
3. The time between pulsations [1]

### Calculations

Since the rectifier is a full-wave bridge rectifier, the frequency is 60Hz

A capacitor value of about 1000 $\mu$ F is used in order to give the required smoothening.

The reactance required is calculated;

$$X_c = 1/(2\pi fc)$$

$$X_c = 1/(2\pi * 1000 * 10^{-6} * 60)$$

$$= 2.653\Omega$$

$$\approx 2.7\Omega$$

Hence a close value of  $2.7\Omega$  was chosen as the limiting resistor.

Current through the capacitor  $= 2\pi fc$

$$= 2\pi * 50 * 1000 * 10^{-6} * 12$$

$$= 3.77A$$

### **3.4 REGULATION**

The d.c output voltage can change for several reasons, the a.c voltage might increase or decrease if this happens the output d.c voltage increases or decreases proportionately to the input change.

### **3.5.0 SWITCHING /COMPARATOR CIRCUIT DESIGN**

LM324 IC is a quad IC which consists of two independent voltage comparators which operates from a single power supply over a wide range of voltages .The comparator circuit is designed to compare voltages from sensing circuit which is fed to the non-inverting input against a reference voltage, which is fed to the inverting input of comparator through a voltage divider network.

### **3.5.1 SENSING CIRCUIT**

The sensing circuit in an AVR measures the changes in the main supply and the output is compared against a reference by the comparator circuits. For this design, two (2) variable resistors measure the variations in the main d.c supply in the form of potential difference.

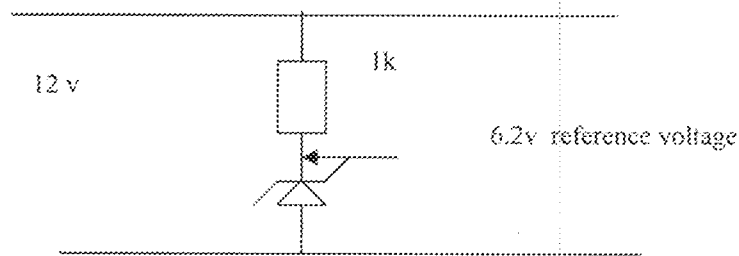

Fig. 3.2 zener diode reference

Zener diode reference voltage,  $V_{ref} = 6.2V$

Power rating = 500 mW

$$I_z = P/V$$

$$= 500/6.2 \text{ mA}$$

$$= 80.6 \text{ mA}$$

Current through  $R_z$  i.e.  $1k\Omega$  resistor is

$$R_z = (V_{dc} - V_{ref})/R_2$$

$$= (12 - 6.2) / 1k\Omega$$

$$= 5.8 \text{ mA}$$

The gain of the comparator

$$A_1 = -R_f/R_{in} = 229k/1k$$

$$= 229$$

Reference voltage,  $V_{ref} = 6.2V$

Adjusting the variable resistor  $V_{R1}$  from  $(0 - 10k\Omega)$ ,

At the maximum value of  $V_{R1}$  of  $10k\Omega$

Voltage through the non-inverting input of comparator  $V_{cp1}$ ,



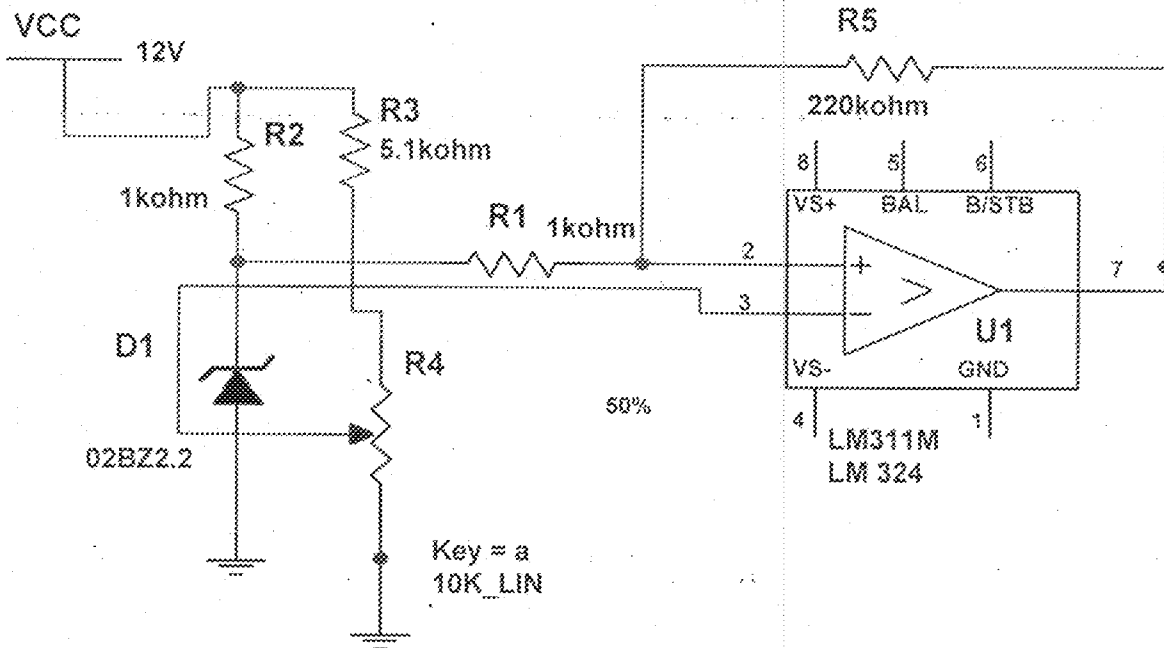

Voltage through the non-inverting input of comparator 1

FIG. 3.2 COMPARATOR 1

FIG. 3.3 COMPARATOR 2

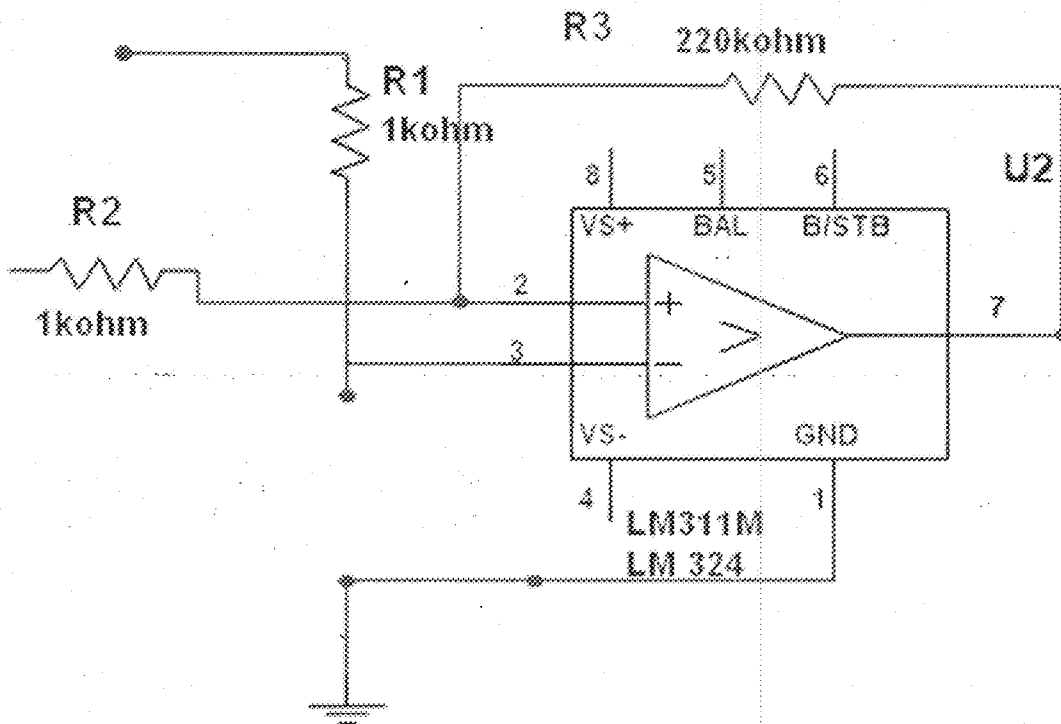

$$\begin{aligned}
 V_{cp1} &= V_{dc} * R_{vr1} / (R + R_{vr1}) \\
 &= 12V * 5k / (10k + 5k) \\
 &= 12 * 5 / 15 \\
 &= 4V
 \end{aligned}$$

Therefore, the voltage swings between (4V - 12V) when  $V_{r1} = 0$ .

$$\begin{aligned}
 \text{at minimum value } V_{cp2} &= V_{dc} * R_{vr2} / R_{vr2} \\
 &= 12V * 5k / 5k \\
 &= 12V
 \end{aligned}$$

$$\begin{aligned}
 \text{The gain of comparator 2, } A_2 &= 220 \\
 &= -R_f / R_5 \\
 &= 220
 \end{aligned}$$

The resistance varies between (5k -----15k)

If the pointer is at the lowest resistance value for variable resistor  $V_{R2}$ ,

$$\begin{aligned}
 \text{The input voltage } V_{in} &= V_{dc} * V_{R2} / (V_2 + R_2) \\
 &= 10k * 12V / (10k + 5k) \\
 &= 12V * 10k / 15k \\
 &= 8V
 \end{aligned}$$

This is the maximum input voltage at the inverting input terminal.

Varying the variable resistor  $V_{R2}$ , the minimum resistance to set the input voltage is zero,

therefore, the input to the inverting terminal ranges from (0 - 8V).

To turn off the comparator 2, the input voltage must be  $\leq 6.2V$  which is the reference voltage.

To turn – off comparator 1, the voltage to the non-inverting input must be between (4V-6.2V).

### 3.6.0 SWITCHING CIRCUIT

The output of the comparator is used to control the switching circuit which comprises both the transistors and the relays depending on the changes in the input supply .The switch actually makes or breaks the electrical circuit depending on the output of the comparators or which comparator is operating at a given time depending on the sensed voltage. [9 ]

#### 3.6.1 SWITCHING ACTION OF A TRANSISTOR

The switching action of a transistor is shown in the figure\_ below indicating the output characteristics of a typical transistor for a common emitter configuration. The load-line is drawn for load  $R_c$  and the collector supply  $V_{cc}$ . The characteristics are arranged in three regions: OFF, ON or saturation and active region

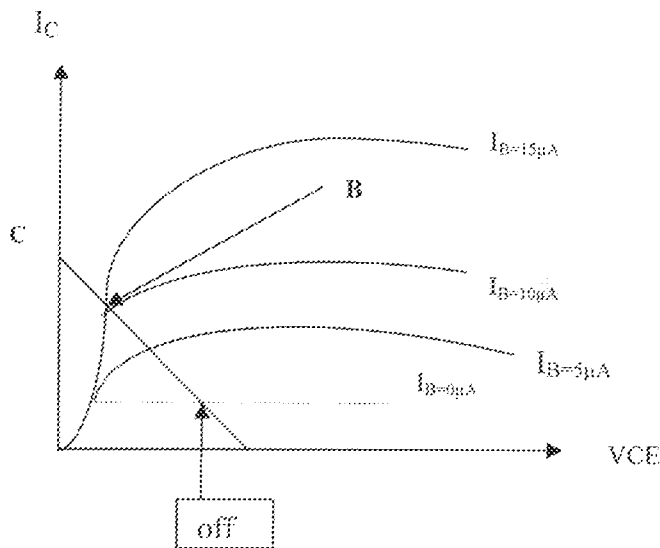

fig. 3.4 characteristics of transistor

1. OFF (cut-off) region, when the input base voltage is zero or negative, the transistor is said to be in OFF condition. In this condition  $I_b = 0$  and the collector current is equal to the collector leakage  $V_{cc}$ , the value of  $I_{cco}$  can be obtained from the characteristic, if  $V_{cc}$  is known.

Power loss = output voltage \* output current

$$\text{Power loss} = V_{cc} * I_{cco}$$

Since  $I_{cco}$  is very small as compared to full-load current that flows in the ON condition, power loss is small in the OFF condition. It means that the transistor has a high efficiency as a switch in the OFF condition.

2. ON or saturation region; when the input voltage is made so much positive that collector saturation collector current flows, the transistor is said to be in the ON condition. In this condition, the saturation collector current is given by

$$I_c(\text{sat}) = (V_{cc} - V_{rms}) / R_c$$

Power loss = output voltage \* output current

The output voltage in the ON state is equal to  $V_{knee}$  and output current is  $I_c(\text{sat})$ ,

$$\text{Power loss} = V_{knee} * I_c(\text{sat}).$$

Again the efficiency of transistor as a switch in the ON state is high. It is because the power loss in this condition is quite low due to the small value of  $V_{knee}$ .

3. Active region; The OFF and ON regions are the stable regions of operation, the active region is the unstable or (transient) region through which the operation of transistor passes while changing from OFF state to ON state. In figure – above line AB is the active region. The collector current increases from  $I_{cco}$  to  $I_c(\text{sat})$  along the path AB as the transistor is switched ON and vice versa when the transistor is switched OFF [9]

### 3.7 RELAY

A relay is an electromagnetic or solid state device operated by varying the input, which in turn is used to control other devices connected to its output. Relays form the simplest form of automatic switching in electric circuit. It is made up of two parts:

1. The coil
2. Magnetic switch.

When electric current is passed through its coil, a magnetic field is formed around it which is proportional to the amount of current flowing through the coil. This cause an armature to be attached and opening or closing contact attached to some point. This system losses it magnetism as current ceases flowing through the coil.

Relays normally having a time integrating blocks, which in most cases are springs which determines the speed of operation. They are available for d.c or a.c excitation and coil voltages ranges from 5V -230V. For this design three (3) relays 12V<sub>d.c</sub> are used.

The primary use of relay is in remote switching, because it is important to keep the electronic circuit electrically isolated from the a.c power-line

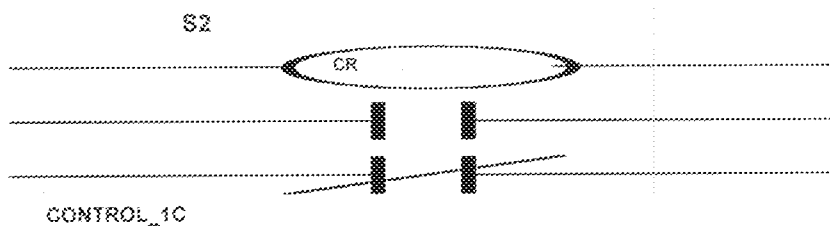

FIGS 3.5 RELAY CIRCUIT

It enables small currents in one circuit to control a much larger current in another circuit or the simultaneous switching of more than one circuit.

### **3.8.0 DELAY CIRCUIT DESIGN**

For the purpose and objectives of this project, the monostable mode of the NE555 timer which has a single output state when triggered is employed.

#### **3.8.1 MONOSTABLE OPERATION**

The timing period is triggered (started when the trigger input (555 pin2) is less than  $1/3V_s$  this makes the output high ( $+V_s$ ) and the capacitor  $C_1$  starts to charge through resistor  $R_1$ . Once the time period has started further triggers are ignored. The threshold input (555 pin 6) monitors the voltage across  $C_1$  and when this reaches  $2/3V_s$  the time period is over and the output becomes low. At the same time discharge (555 pin7) is connected to 0V, discharging the capacitor ready for the next trigger. [13]

The reset input (555 pin4) overrides all other inputs and the timing may be cancelled at any time by connecting reset to 0V, this instantly makes the output low and discharges the capacitor. If the reset function is not required the reset pin should be connected to  $+V_s$ .

#### **3.8.2 POWER-ON RESET OR TRIGGER**

It may be useful to ensure that a monostable circuit is reset or triggered automatically when the power supply is connected or switched ON. This is achieved by using a capacitor instead of (or in addition to) a push switch as shown in the diagram below.

The capacitor takes a short time to charge briefly holding the input close to 0V when the circuit is switched ON. A switch may be connected in parallel with the capacitor if manual operation is also required.

### 3.8.3 EDGE – TRIGGERING

If the trigger input is still less than  $1/3V_s$  at the end of the time period the output will remain high until the trigger is greater than  $1/3V_s$  .this situation can occur if the input signal is from ON \_OFF switch or sensor .

The monostable can be edge trigger , responding only to changes of an input signal by connecting the trigger signal through a capacitor to the trigger input .The capacitor passes sudden charges (a.c) but blocks a constant (d.c) signal .The circuit is negative edge triggered because it responds to a sudden fall in the input signal .

The resistor between the trigger (555 pin2) and  $+V_s$  ensures that the trigger is normally high ( $+V_s$ ). [7, 5]

### 3.9.0 LOGIC CIRCUIT DESIGN

The latch is a type of bistable storage device that is normally placed in a category separate from that of flip-flops because they are bistable devices that can reside in either of two stage by virtue of a feedback arrangement in which the outputs are connected back to the opposite inputs .The main difference between latches and flip- flops is in the method used for changing their state.

#### 3.9.1 THE S- R LATCH

A latch is a type of bistable multivibrator .An active HIGH input S-R (Reset – Set) latch is formed cross-coupled NOR gates; an active – low input S – R latch is formed with two cross-coupled NAND gates and is connected to an input of the opposite gate .

Fig.3.6 S-R Latch

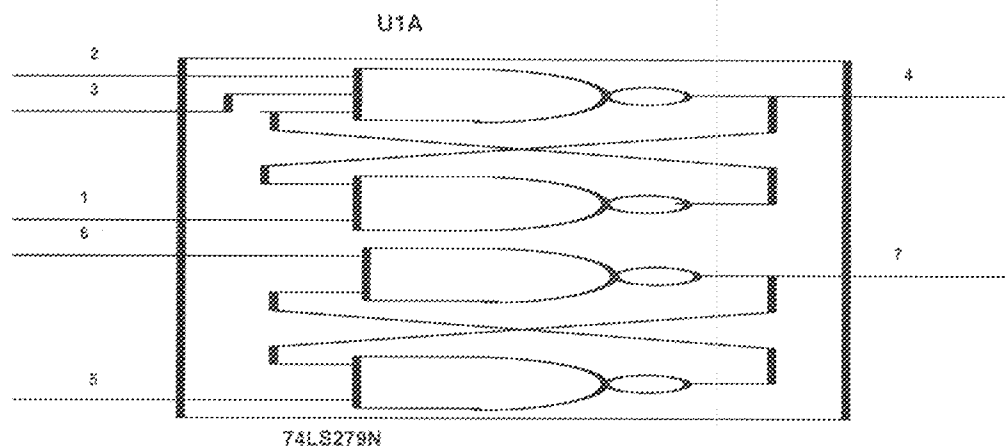

When the Q output is HIGH, the latch is in the SET state. It will remain in this state indefinitely until a LOW is temporarily applied to the R- input with a low on the R- input and a HIGH on S- , the output of gate  $G_2$  is forced HIGH. This high on the Q- output is coupled back to an input of  $G_1$  , and since the S- is HIGH ,the output of  $G_1$  goes low. This low on the Q output is then coupled back to an input of  $G_2$  ensuring that the Q- output remains HIGH even when the low on the R- input is removed. When Q output is LOW the latch is in the RESET state. Now the latch remains indefinitely in the RESET state until a LOW is applied to the S- input

The outputs of a latch are always complements of each other; when Q is LOW Q-is HIGH. An invalid condition in the operation of an active -low input S- R- latch occurs when lows are applied to both S- R-at the same time. As long as the low levels are simultaneously held on the inputs, both the Q and Q- inputs are forced HIGH, thus violating the basic complementary operation of the outputs. Also if the lows are released simultaneously ,both outputs will attempt to go LOW. Since there is always some small difference in the



propagation delay time of the gates. One of the gates will dominate in its transition to the LOW output state. This in turn forces the output of the slower gate to remain HIGH. [8]

### 3.10 SEVEN SEGMENT DISPLAY CIRCUIT

Each segment (a through to g) contains an LED as shown by the seven symbols. The display shown has all the anodes tied together and coming out of the right side as a single connection (common anode). The inputs on the left go to the various segments of the display.

To understand how segments on the display are activated and lit as shown in figure 7(c), if switch b is closed, current flows from GND through the limiting resistor b, segment LED and out the common anode connection to the power supply. Only segment b will light.

Suppose you wanted decimal 2 to light on the display in fig.7c. Switches a, b, d, e, and g would be closed, lighting the LED segments a, b, d, e, and g. The decimal 2 would light on the display. Likewise, if decimal 0 were to be lit, switches a, b, c, d, e and f would be closed. These five switches would ground the correct segments, and a decimal 0 would be appear on the display. Note that it takes a GND voltage (LOW logic level) to activate the LED segment on this display. [3,14]

on the display .Note that it takes a GND voltage (LOW logic level) to activate the LED segment on this display . [3]

SEVEN\_SEG\_DISPLAY

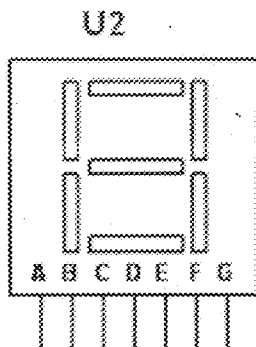

SEVEN\_SEG\_DISPLAY

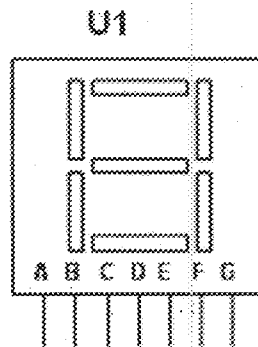

SEVEN\_SEG\_DISPLAY

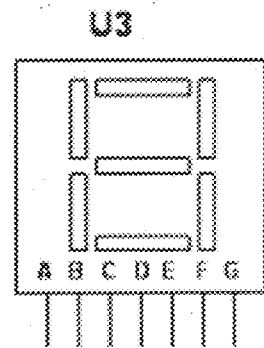

fig 3.7

### 3.11 DESIGN OF 1KVA AUTO – TRANSFORMER

Auto-transformer is a transformer with one winding only, part of this being common to both primary and secondary. The primary and the secondary are not electrically isolated from each other unlike 2-winding transformer and its transformation ratio differs from unity.

The following assumptions were made to achieve the desired objectives:

Volt/turn  $= 0.15$ .

Standard frequency  $f = 50\text{Hz}$

Maximum flux density,  $B_m = 0.4\text{T}$

Current density  $J = 1\text{A/mm}^2$

Iron space factor,  $K_o = 0.64$

Stacking factor,  $K_s = 0.99$

Volts/turn/(KVA/phase) <sup>1/2</sup> = 4.44FB <sub>m</sub> Ac.....	1
Transformation Ratio, K = E <sub>s</sub> /E <sub>p</sub> = N <sub>s</sub> / N <sub>p</sub> .....	2
1KVA= 2.22 FB <sub>m</sub> AcKwJAw.....	3
The square of length of stacking is directly proportional to the Area of Core; Ac	
Also, Ac = KoK <sub>s</sub> WDo / 4.....	4
Do = Core circle diameter	
Window width is given as,	
W = X /2.....	5
Ac = X <sub>L</sub> (where X is the core width).....	6
Number of laminations, NL = L/ l.....	7

From equation 1

$$\begin{aligned}
 Ac &= (\text{volt/turn})/(\text{1KVA/phase})^{1/2}/4.44\text{FB}_m \\
 &= 0.15 / (1*4.44*0.4* 50 ) \\
 &= 16.89 \text{ cm}^2
 \end{aligned}$$

For this design the power rating is 1KVA

Recall;

V<sub>p</sub> = primary voltage

V<sub>s</sub> = secondary voltage

N<sub>p</sub> = number of turns in primary

N<sub>s</sub> = number of turns in secondary

Transformation Ratio, K is

$$(\text{Volts /turn}) /(\text{KVA/phase})^{1/2} = 4.44\text{FB}_m\text{Ac}$$

## MATHEMATICAL RELATIONS /CALCULATIONS

$$K = V_s / V_p = I_p / I_s = E_s / E_p = N_s / N_p \dots \dots \dots 8$$

Power = voltage (v) \* Current (i)

$$KVA = V * I$$

Where V is the rms voltage

I is the rated current in Amperes

Therefore,

$$\begin{aligned} \text{Maximum current } I_{\text{max}} &= KVA / V_{\text{rms}} \\ &= 1000 / 220 \text{ A} \\ &= 4.55 \text{ A} \end{aligned}$$

The total number turns in the winding NT = 71+54+113+85+355+41 = 759 turns

The auto – transformer is designed in such a way to give three different tapping voltage with respect to the output.

Let the secondary turns be labeled as N<sub>s0</sub>, N<sub>s1</sub>, N<sub>s2</sub>. For normal input voltage of 220V, the output will be maintained at 220V.

$$\begin{aligned} N_{s0} &= V_p N_p / V_s \\ &= 220 * 759 / 220 \text{ turns} \\ &= 759 \text{ Turns.} \end{aligned}$$

This means that at normal operations the number of turns in primary winding is equal to that in the secondary winding when the input voltage increases to about 250V.

$$\begin{aligned} N_{s1} &= 220 * 759 / 250 \text{ turns} \\ &= 668 \text{ turns} \end{aligned}$$

Where there is a further increase in from normal 220V to say 280V

$$N_{s_2} = 220 * 759 / 280 \text{ turns}$$

$$= 596 \text{ turns.}$$

When there is a further decrease in input voltage say from 220V to 190V

$$N_{s_3} = 220 * 759 / 190 \text{ turns}$$

$$= 878 \text{ turns.}$$

This implies that the number of turns increases with a decrease in voltage.

### Current in the windings

$$I_p = KVA / 0.9 V_p$$

$$= 1000 / (0.9 * 220)$$

$$= 5.05 \text{ A}$$

$$I_{s_0} = KVA / V_{s_0}$$

$$= 1000 / 220 \text{ A}$$

$$= 4.55 \text{ A}$$

$$I_{s_1} = KVA / V_{s_1}$$

$$= 1000 / 250 \text{ A}$$

$$= 4.00 \text{ A}$$

$$I_{s_2} = KVA / V_{s_2}$$

$$= 1000 / 280 \text{ A}$$

$$= 3.57 \text{ A}$$

$$I_{s_3} = KVA / V_{s_3}$$

$$= 1000 / 190 \text{ A}$$

$$= 5.26 \text{ A}$$

## Area of the winding conductors

Where  $I$  = current (A)

$$A = \text{area (mm}^2\text{)}$$

$$J = 257 * 10^4$$

$$\text{Area} = I / J$$

$$A_p = 5.05 / (257 * 10^4) = 1.95 \text{mm}^2$$

$$A_{s0} = 4.5 / (257 * 10^4) = 1.77 \text{mm}^2$$

$$A_{s1} = 4.00 / (257 * 10^4)$$

$$= 1.57 \text{mm}^2$$

$$A_{s2} = 3.57 / (257 * 10^4)$$

$$= 1.39 \text{mm}^2$$

$$A_{s3} = 5.26 / (257 * 10^4)$$

$$= 2.05 \text{mm}^2$$

## CHAPTER FOUR

### 4.0 BILL OF ENGINEERING MATERIALS AND EVALUATION

S/N	DESCRIPTION	QUANTITY	RATE ₦	AMOUNT ₦
1	RESISTORS	19	10	190
2	CAPACITOR	3	20	60
3	LM324 IC	1	200	200
4	555 TIMER	1	70	70
5	74LS279 IC	1	200	200
6	DIODES	12	10	120
7	BRIDGE RECTIFIER	1	80	80
8	AUTO-TRANSFORMER	1	1000	1000
9	S.S.D	3	250	750
10	TRANSISTORS	2	40	80
11	RELAYS	4	80	320
12	LED INDICATORS	4	10	40
13	IC SOCKET	3	50	150

Table 4.0

## CONSTRUCTION, TESTING AND DISCUSSION OF RESULTS

### 4.1 CONSTRUCTION;

At this point, the various components were soldered on a Vero board. The soldering was done at intervals; the circuit was tested to check if it gave the desired output. The step down transformer was first mounted on the board and connected to the mains supply and its voltage measured with a multimeter. The output was observed to be 12V a.c form. This a.c output voltage was fed into a four diodes network arrangement to convert a.c to d.c. The d.c voltage so obtained was fed through a filter circuit to remove the remaining ripples in the system. The 1000 $\mu$ F capacitor was soldered on the board to filter the output of the rectifier. The output of the filter was measured and found to be 12V d.c. A 6.2 V zener diode was soldered at the output of the filter to regulate the 12V d.c filtered to about 6.2 V, but when it was measured using a multimeter, it read 6V at the output of the regulator. A 2.2 $\mu$ F capacitor was soldered across the zener diode to further remove existing ripples present in the current; also soldered across the output of the zener diode is a 1K $\Omega$  resistor.

The base of the I.C LM324 was soldered on the board and the IC was mounted on the socket. Pin 3 of the comparator 1 was connected to the non-inverting input, through a 1K $\Omega$  resistor to variable resistor  $V_{R1}$ , and the inverting input at pin 2 was connected to the output of the zener diode to represent a reference voltage of the IC serving as comparator 1. 220K $\Omega$  resistor was connected between pin 3 and pin 1, while pin 4 was connected to +V<sub>cc</sub>, pin 1 was connected to BC 109 transistor (NPN) through a 1K $\Omega$  resistor.

Comparator 2 had its pin 5 connected to the output of the zener diode through a 1K $\Omega$  to tap the reference voltage for the second comparator. Pin 6 was connected to the variable



resistor  $V_{R2}$  through a  $1K\Omega$ . A  $220K\Omega$  resistor was connected between pin 5 and pin 7. Pin 8 was connected to  $+V_{cc}$  and pin 11 to ground. Pin 7 was connected to the second (NPN) BC109 transistor also through a  $1K\Omega$  resistor.

The collectors of both transistor were connected to the relays in series and IN4001 diodes were connected across each relay, across pin 4 and pin 1. The emitters of both transistors were connected to ground while the relays were connected to  $+V_{cc}$ . The contacts of the relays normally opens and normally closes while coil pin 1 and 4 were energized, normally open contacts closed. This performed the switch over i.e. either to high voltage 250V or low voltage of 190V.

Terminal 2 of the first relay was connected to 250V terminal of the auto-transformer, also terminal 3 of the second relay was connected to 190V terminal of the auto-transformer while live wire was connected to the terminal 2 of the relay to serve as one of the output line. Relay RL2 operated and change to terminal 2 when the voltage was normal at 220V i.e none of the relays "operates" and switch over to the supply line voltage and at the same time perform the necessary switching operation required for the alternation of the auto-transformer output terminals

Similarly, for the operation of the digital display to be actualized, two relays were soldered to the Vero board and the terminals were connected to the inputs of the 555 timer which is the delay circuit. 9V d.c was supplied through pin 8 to energized the delay circuit which undelays and SET the output pin 3 to a HIGH which is connected to the input of the logic circuit which is a quad – latch. Pin 2 of the logic IC was connected to a high while pin 3 was grounded, through NAND gates operating as flip-flops and the output gave a HIGH, which was connected to the display circuit in common anode configuration to display 220V at the output.

was grounded, through NAND gates operating as flip-flops and the output gave a HIGH, which was connected to the display circuit in common anode configuration to display 220V at the output.

Whenever the supply falls below 220V, resulting in the Vcc to the timer IC falling below 9V, and a LOW output from the timer is connected to the input of logic circuit resulting in outputs pin 4 to be LOW and pin7 to a HIGH, this result is connected to terminals; b and c of the display circuit via relay terminals for an output of 220V to be displayed.

## **4.2 TESTING**

Every constructed stage starting from the rectifier circuit, switching circuit, the auto-transformer output, the voltage level indicators were tested at various times of the day with different voltage sensitive electronic devices such as: computer, radio, printer etc to verify the design specifications.

## **4.3 RESULTS**

The supply from the mains was measured with multimeter at various input voltage levels: 250v, 240v, 190v etc, and in all case, the regulator read 220v constantly. The institute of Electrical engineering regulation stipulates that for safe utilization of electrical energy, the fluctuations from normal supply at any given time must not exceed + or - 6%.

## CHAPTER FIVE

### 5.0 CONCLUSIONS AND RECOMMENDATION

#### 5.1 CONCLUSIONS

From the results obtained from the testing of the (AVR), reveals beyond any reasonable doubts that (AVR) can provide the necessary protection against fluctuations, surges etc when used under the predesigned specifications and environment. It regulates the supply voltage to a more comfortable voltage required by electronic devices at the instant of noticing abnormal voltage behaviors.

#### 5.2 RECOMMENDATIONS

For this design to perform much better, the followings are my recommendations;

1. Increasing the number taps of the auto-transformer would enhance the sensitivity of the (AVR) and also increasing the numbers of relays to increase the switching speed of the AVR.
2. The digital display should be design for the input as well through the use of decoders and drivers which are more sensitive to voltage changes.
3. Though, the desired objectives of having digital display at the output was attained through the use of logic IC and relays, its sensitivity to variations in input supplies is quite slow but can be enhanced through the use of decoders and counters.

## REFERENCES

- [1] Charles A. Schuler, Electronics Principles and applications, McGraw-Hill, London- UK,1993, pp.55-78
- [2] Dugger Patrick and Sues Ziegler, Basic Electronics systems technology, pp.131-138
- [3] Tokheim, Digital Electronics Principles and application, Sixth Edition, pp.185-186.
- [4] G.K. Mithal and Maneesha Gupta, Industrial and Power Electronics, Nineteenth Ed. Pp.80-83.
- [5] George B. Clayton, Linear Integrated circuit applications, The Macmillan Press Ltd, London, pp-91-97.
- [6] B. L. Theraja and A. K. Theraja, A Text Book of Electrical Technology, Revised Ed. S- Chand and Company, Ram Nagar, New Delhi, 2002, pp-972-976.
- [7] <http://www.kpsec.freeuk.com/555timer.htm>, 555 and 556 Timer Circuits, page 6 of 9-pg 8 of 9.
- [8] Thomas L.FLloyd, Digital Fundamentals,6<sup>th</sup> Ed,Prentice-HallInternational, Inc,New Jersey-07458,1997.
- [9] V.K.Mehta,Shalu Mehta, Principles of Electronics, S.Chand and company LTD,Ram Nargar,New Delhi-110055,2004.
- [10] Paul H. Winfield H.,The Art of Electronics, Cambridge Low priced Edition,pp311-315, 1997.

APPENDIX A

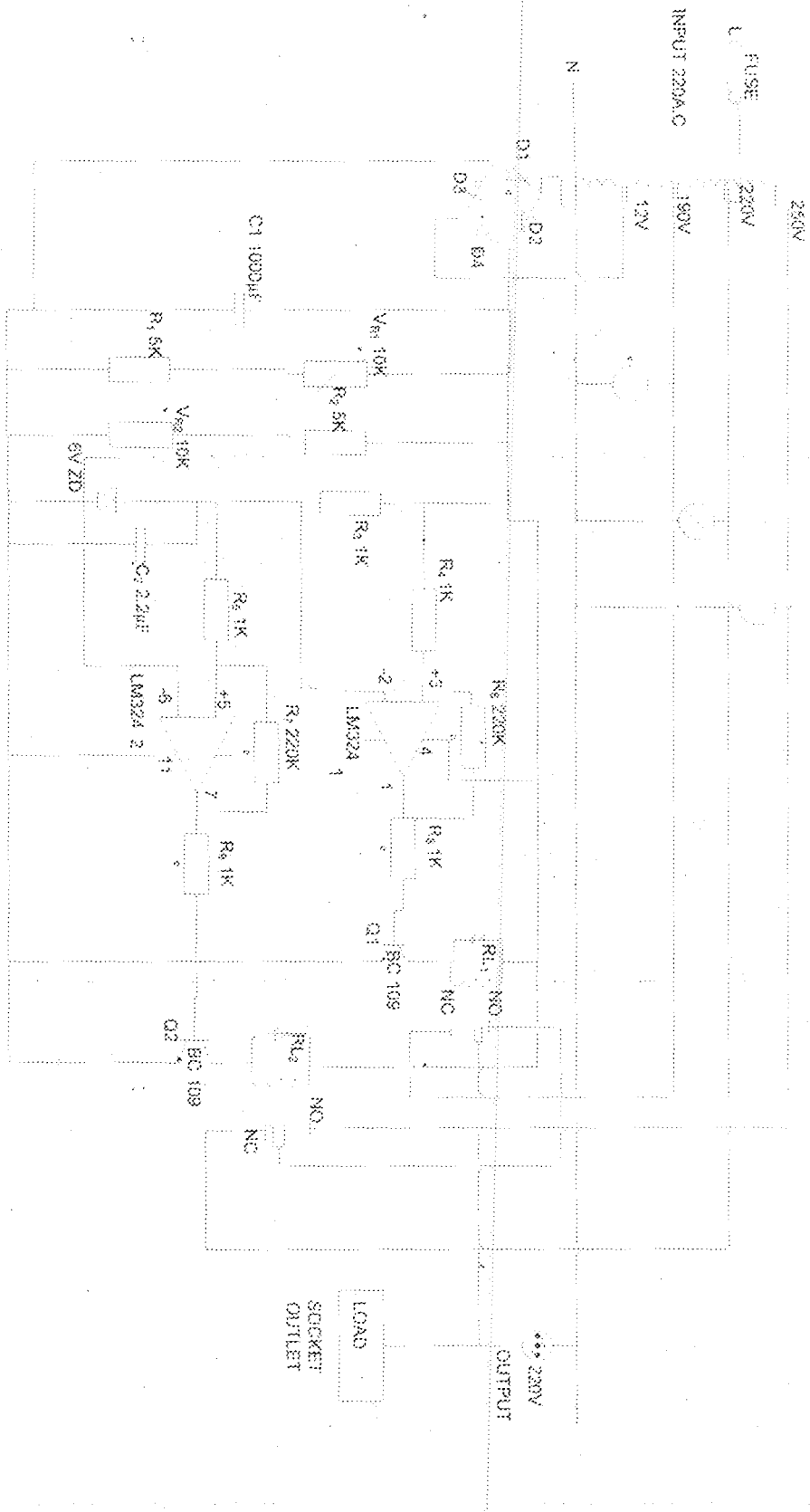

FIG. 4 AUTOMATIC VOLTAGE REGULATOR CIRCUIT DIAGRAM

