

**DESIGN AND CONSTRUCTION OF AN ELECTRICAL
WORKBENCH DEVICE INCORPORATED WITH A DUAL
POLARITY POWER SUPPLY, FUNCTION GENERATOR AND A
FREQUENCY METER.**

BY

AIYEDUN NUKUDEEN. A

(93/ 3508)

**A PROJECT REPORT SUBMITTED IN PARTIAL FULFILMENT OF THE
REQUIREMENT FOR THE AWARD OF A BACHELOR OF
ENGINEERING (B.Eng.)
DEGREE IN THE**

**DEPARTMENT OF ELECTRICAL AND COMPUTER
ENGINEERING, SCHOOL OF ENGINEERING AND
ENGINEERING TECHNOLOGY, FEDERAL UNIVERSITY OF
TECHNOLOGY, MINNA, NIGERIA.**

MARCH, 2000.

DEDICATION

This project is dedicated to ALHAJI R.A AIYEDUN and HAJIA B.O AIYEDUN.

DECLARATION

I hereby declare that this project work was wholly conducted by me under the able supervision of Dr. Y.A Adediran, Head of Department of Electrical and Computer Engineering, Federal University of Technology, Minna.



Signature

24-03-2000

Date.

CERTIFICATION

This is to certify that this project titled "DESIGN AND CONSTRUCTION OF AN ELECTRICAL WORKBENCH DEVICE INCORPORATED WITH A DUAL POLARITY POWER SUPPLY, FUNCTION GENERATOR AND A FREQUENCY METER" was carried out by AIYEDUN NURUDEEN.A under the supervision of Dr. Y. A ADEDIRAN and submitted to Electrical and Computer Engineering Department, Federal University of Technology, Minna in partial fulfillment of the requirements for the award of Bachelor of Engineering (B.ENG) degree in Electrical and Computer Engineering.

Dr. Y A. ADEDIRAN

Project supervisor

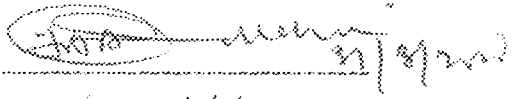
sign and date

Dr. Y. A. ADEDIRAN

Head of department

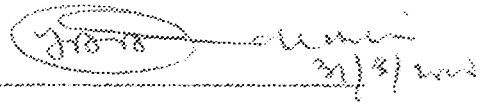
sign and date

Dr. J. O. ONI

External examiner

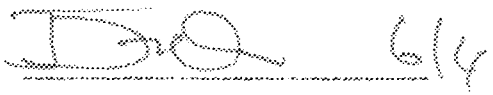
sign and date

ACKNOWLEDGMENT

All praise be to Allah, the most gracious and the most merciful, who has seen me through the successful completion of this project. My profound gratitude goes to my parents ALHAJI and HAJIA R.A AIYEDUN who also made this project a reality for their moral and financial support and to my brothers and sisters for their concern and encouragement.

A special thanks goes to my supervisor, Dr Y.A.ADEDIRAN who gave me the opportunity to work under him. To my colleagues, OMOTAYO A.O and ADESIYAN A.A together with whom this project was carried out.

Finally, I must thank all my classmates and friends like: Sadiq Ahmed, Olaleye, Jinadu, Seun, Olatunji, Sholanke, Adeniji, Omitayo, Olayinka, Shade, Kibiya, Sulaiman, Jalla, Manzo, Abdullahi, Habeeb, Gobir, Alabi and others for the concern they showed, and their contributions to this project.

TABLE OF CONTENTS

TITLE	PAGE
TITLE PAGE	I
DEDICATION	II
DECLARATION	III
CERTIFICATION	IV
AKNOWLEDGEMENT	V
TABLE OF CONTENTS	VI
ABSTRACT	VII
CHAPTER ONE	
1.1 INTRODUCTION	1
1.2 PROJECT OBJECTIVES AND MOTIVATION	2
1.3 METHODOLOGY	2
1.4 LITERATURE REVIEW	6
1.5 PROJECT OUTLINE	7
CHAPTER TWO	
2.0 SYSTEM DESIGN	8
2.1 VARIABLE POWER SUPPLY	8
2.2 FUNCTION GENERATOR	16
2.3 FREQUENCY METER	24
CHAPTER THREE	
3.0 CONSTRUCTION, TESTING AND RESULT	29
3.1 CONSTRUCTION TECHNIQUES	29
3.2 TESTING	30
CHAPTER FOUR	
4.0 RECOMMENDATION AND CONCLUSION	31
REFERENCES	32

ABSTRACT

This project work is an electrical workbench device incorporated with three functional units. The units are, a dual polarity power supply, a square, triangular and sine wave function generator and a frequency meter.

The device has the capability to display its output in digital form.

CHAPTER ONE

GENERAL INTRODUCTION

1.1 INTRODUCTION

An electrical workbench device is any piece of electrical device that can be used for practical work in an electrical laboratory or workshop. Workbench devices are generally handy and small thereby making it easy to carry around and work with. This project work is a workbench device that is incorporated with a dual polarity power supply, a function generator and a frequency meter. The peculiar feature of this device is its digital display unit. There are numerous sources of direct current for electronic equipment. Batteries are the commonest of these sources. Batteries are used for practical work in laboratories but its limited life span makes it uneconomical. A more acceptable alternative and a less costly one is possibly to rectify a.c mains.

A power supply can simply be defined as an electronic circuit designed to provide various a.c and d.c voltages at low levels for equipment operation. The power supply in this workbench device is designed to have a variable output from $\pm 1V$ to $\pm 15V$

A complete power supply circuit has the following functions as shown in figure 1.1

1. Step up or step down by transformer action of a.c line voltage to required voltage.
2. Change a.c voltage to a pulsating d.c voltage by either halfwave or fullwave rectification.
3. Filter pulsating d.c voltage to a pure d.c voltage for equipment use.
4. Regulate power supply output in proportion to the applied load

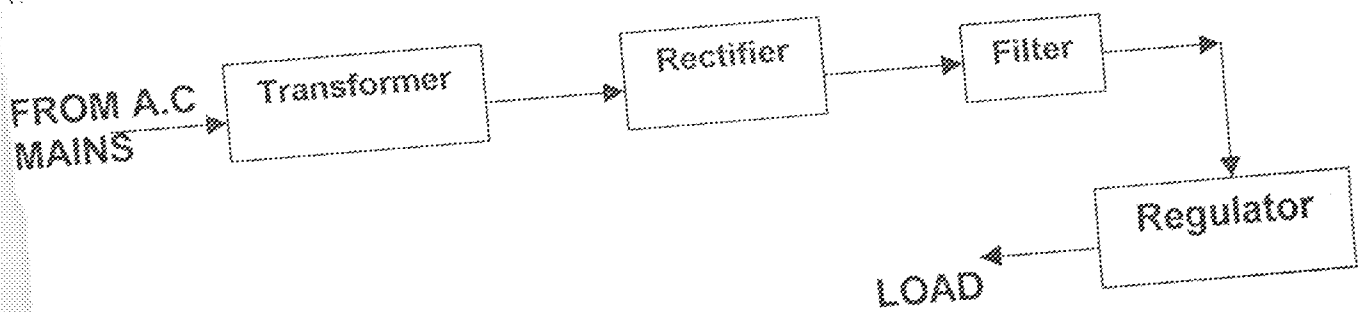

FIG 1.1 BLOCK DIAGRAM OF A POWER SUPPLY UNIT.

Another functional unit in the workbench device is the function generator. The term signal generator is often applied to an oscillator which has the capability of being modulated, while a function generator has a variety of output waveshapes whose frequency are adjustable over a wide range. These waveshapes could be sinusoidal, square, triangular, sawtooth e.t.c. The generation of signals is an important facet of electronic troubleshooting and development. A signal source is used to provide known test conditions for performance evaluation of various electronic systems, replacing missing signals, timing and control and for modulation functions. The characteristics of output signals from signal sources are widely varied because they are dictated by the need of the equipment they are designed to serve, thus bringing about function generator of various types involving various kinds of waveforms over a wide portion of the frequency spectrum and capable of various power levels, usually small.

The final unit of the device is the frequency meter. A frequency meter measures the number of cycles in an unknown signal during an accurately known interval of time.

1.2 PROJECT OBJECTIVES AND MOTIVATION

The objectives of this project work are to design and construct an electrical workbench device that is handy, easy to work with, versatile and highly reliable. The motive is to have a project work that will help put to application knowledge acquired in the classroom in a way to cover virtually all fields taught. The project motivation can also be linked to the desire to have a project work that will be highly beneficial to our junior colleagues in carrying out practical works in the laboratory

1.3 METHODOLOGY

The project work is sectioned into three functional units and these are variable power supply unit, function generator unit and the frequency meter unit. A multiple output transformer rated 3000mA, 20V, 25V-0-25V and 5V is used for the system construction. A bridge rectifier is used for rectification so as to conserve space on the veroboard while the center-

tap output of transformer provides the dual polarity output. The filter output serves as input to variable regulators as well as analog to digital converter regulator.

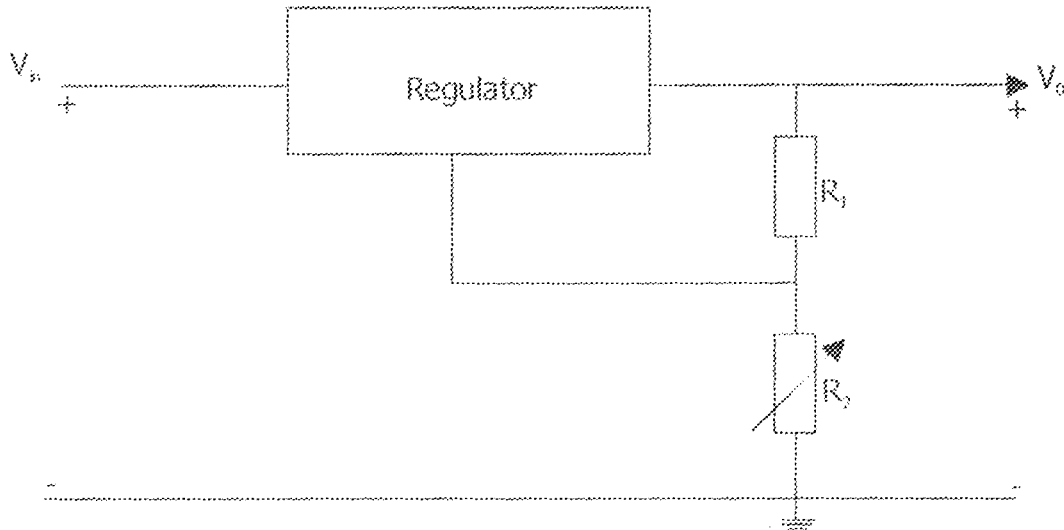

FIG 1.2 REGULATOR CIRCUIT

The variable regulator is connected as shown in figure 1.2. The variable resistors in figure 1.2 are used to determine the regulated output voltage. Regulator output as scaled via a divider network before being fed into the analog to digital converter so as to meet the specified input to the A/D converter. The A/D converter drives four 7-segment displays directly to produce a digital equivalent of the variable output voltage

The function generator is a combination of passive and active component. The square and triangular waves were obtained by connecting a comparator and an integrator as in figure 1.3.

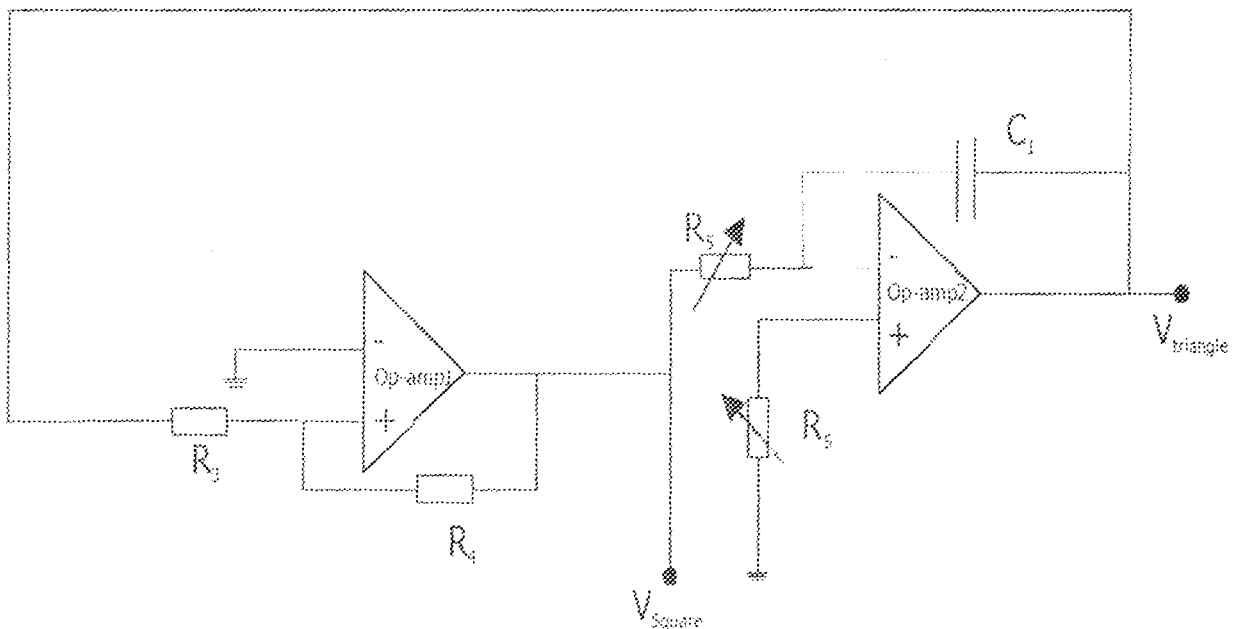

FIG 1.3 SQUARE/ TRIANGULAR WAVE GENERATOR CIRCUIT

The comparator in figure 1.3 has a positive feedback, while the output serves as input to the integrator, but the integrator output is feedback to the non-inverting input of the comparator thereby forming a closed loop. Hence, once the operational amplifiers are properly biased, oscillation is guaranteed. Gang tuning the integrator resistors R_5 makes the output frequency variable. The Wein-bridge circuit in figure 1.4 is used to generate the sign wave.

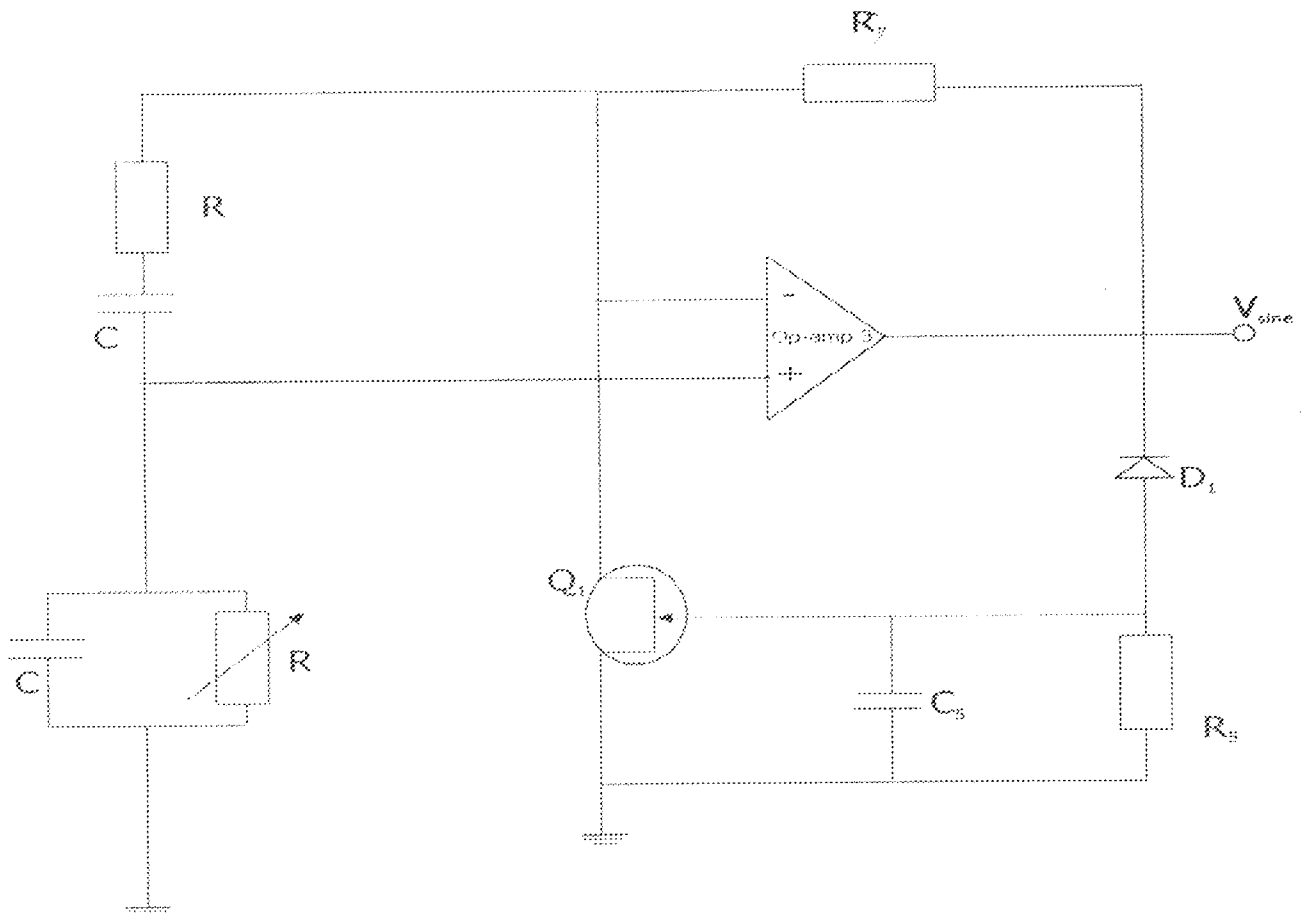

FIG. 1.4 SINE WAVE OSCILLATOR CIRCUIT

The input to op-amp in figure 1.2 is at the non-inverting terminal and it has a positive feedback. For proper functioning of this circuit the Barkhausen criteria must be met. The criteria states that:

1. The magnitude of the loop gain should be unity.
2. The phase shift of the loop gain should be 0° or a multiple of 360° at the frequency of interest.

These criteria were met in the system design. The JFET in the circuit of figure 1.4 serves as an input resistance to the inverting terminal of the op-amp and this is for amplitude stabilization independent of any change in supply voltage. The output of the op-amp is feedback to the gate of the JFET after rectification and smoothing. The dynamic resistance

of the JFET varies linearly with its gate to source voltage V_{GS} for small values of drain to source voltage V_{DS} , therefore any variation in the supply voltage which apparently changes the output voltage will change the dynamic resistance of the JFET thus, keeping the output constant. The output frequency is made variable by gang-tuning resistors R_B . The frequency of the signals are readable on a seven – segment display unit and this was achieved by switching in either the square wave output or the pulse equivalent of the sine wave produced by a Schmitt trigger circuit into an AND gate whose other inputs are a sample pulse and a JK flip-flop output. The sample pulses determine how long the counters will count and a 555 timer at a frequency of 100 kHz generates it. This frequency is further divided to get smaller clock times.

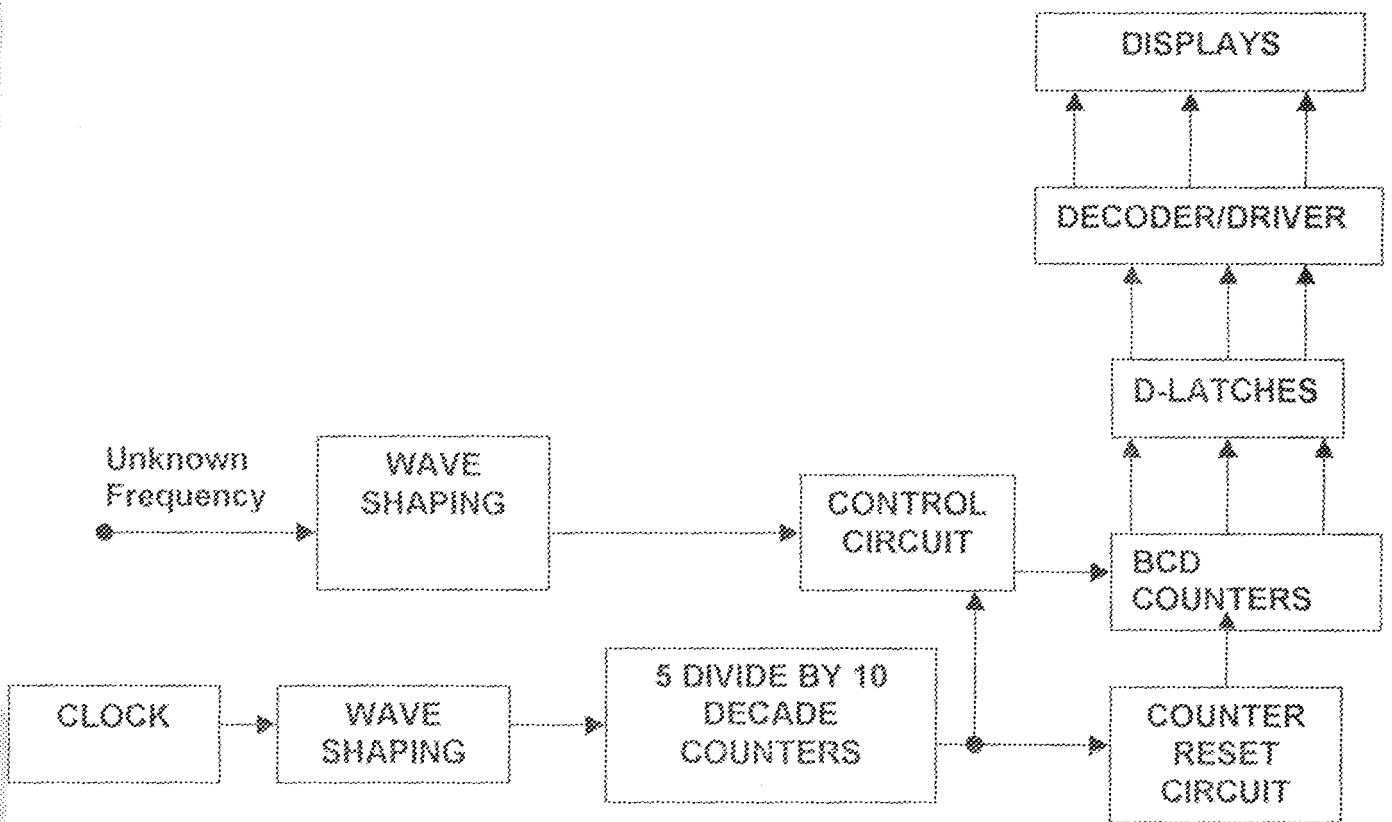

FIG. 1.5 BLOCK DIAGRAM OF FREQUENCY COUNTER

Figure 1.5 shows the block diagram of the frequency meter unit. Their output of the AND gate in figure 1.5 goes into a series of five cascaded decade counters. A monostable multivibrator of two seconds timing provides clear signals to the counters, therefore latches were used to store the counter output at any instance. The output from the latches drives a series of cascaded five binary to decimal decoder drivers which, in turn, drive the seven segment display unit. An external switch serves as an arbiter between the function generator frequency to be displayed and an external frequency to be measured.

4 LITERATURE REVIEW.

There are various kind of electrical workbench devices, which are incorporated with one or more functional units such as power supplies digital voltmeters and so on. There was much activity in seeking knowledge about the nature of electricity in the 18th century, but significant progress came only after the invention of the primary cell by Volta in 1800. Prior to that time experimenters had only high voltage sources possessing very high output impedance, but in the 1800, the electric primary cell became generally available. Its low output impedance, reasonable long duration of operation, low voltage and ease of manufacture was admirably suited to the need of the gentleman scientist of those times. Progress was steadily made in gaining understanding of the fundamental nature of practically useful electrical circuits and devices and in their everyday use.

A chance encounter occurred in the latter part of 19th century, this being discovery of the Edison effect. It was proved, experimentally, that a thermionic device could rectify alternating current. By 1900, designers of telegraph, telephone, and radio communications needed three important improvements in technological capability. Telecommunication needs provided strong commercial reasons to seek them. These needs were: how to amplify a weak electrical signal, how to rectify radio frequency and alternating current, and how to generate radio frequency current. The first decade of the 20th century saw these three basic needs being met by the invention of one basic device, the thermionic valve. It first emerged as the purposefully built diode in which the Edison effect was utilized. The diode was capable of rectification and signal generation. Soon, after, the triode valve was devised; it could perform all forms of amplification, rectification and generation. By the 20s, the thermionic device had evolved into many forms satisfying many needs. Tuned circuits and special purpose devices built with valves as their basis developed: the bistable flip-flop and d.c amplifier being examples that initially fulfilled some special needs.

Basically, valve-based electronic circuitry was then too expensive, too unreliable and too sophisticated for the times to find the wide spread use that we have come to accept for it today. Valves used too much power, they ran at too high a temperature, they were too

large, they cost too much, and they were not reliable to be used in huge numbers. In the 1940 decade, the transistor was devised at the Bell laboratories. It did not emerge quite as suddenly as it might seem but came about from gradual evolution of earlier work on solid-state diode of the 1900 era and after. Valves, in fact being able to satisfy many of the designer's early needs, tended to slow down development of solid-state devices. From the invention of the practical transistor onward, there has been a great increase in the pace of electronic development. Integration made devices smaller, cheaper and far less power consuming. This has enabled the basic level of systems to be gradually, at a very quickening pace, extended in sophistication. Frequency counters would normally have been assembled from discrete components using individually picked transistors; but today, the whole multi-decade counter, with its display, would normally be purchased as a single basic commercial unit that is vastly smaller, far more reliable, and much less costly.

1.5 PROJECT OUTLINE

The project is organized in four chapters. Chapter one gives the general introduction of the whole work, the literature review and the project methodology. Chapter two shows in detail, calculations of how some component values were arrived at and important specifications from manufacturers of certain integrated circuit chips.

Chapter three provides an insight into the construction techniques and testing of the device.

Chapter four contains the conclusion, recommendation and references.

CHAPTER TWO

SYSTEM DESIGN

This chapter shows in detail design procedures and calculation for each functional unit of the whole device. The system functional unit are highlighted below

- 1 Variable power supply.
- 2 Function generator.
- 3 Frequency meter.

2.1 VARIABLE POWER SUPPLY

The specifications for this unit are:

- i. Variable outputs of 0V to $\pm 15V$ and 0mA to 1500mA.*
- ii. Digital readout.*

Output voltage and regulator.

To select a step down transformer for a.c mains, the transformer turns ratio is got from the average d.c output of any full wave rectifier.

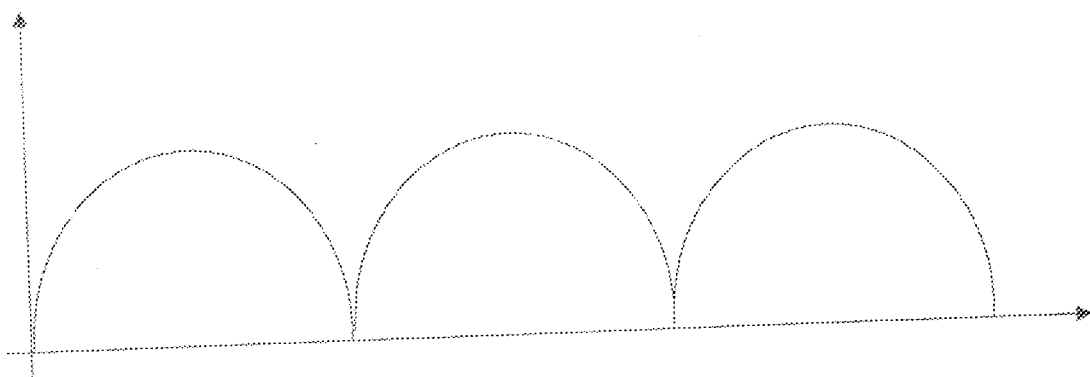

FIG 2.1 OUTPUT WAVE FORM OF A FULL WAVE RECTIFIER.

$$v(t) = V_s \sin \omega t$$

V_s — Rms value of transformer secondary voltage

V_p — Peak value of transformer secondary voltage

V_{dc} — Average dc value of rectified output voltage

$$V_p = \sqrt{2}V_s$$

$$V_{dc} = \frac{1}{\pi} \int_0^{\pi} V_s \sin \omega t dt = \frac{1}{\pi} [-V_s \cos \omega t]_0^{\pi}$$

$$= -\frac{1}{\pi} [\sqrt{2}V_s \cos \pi - \sqrt{2}V_s \cos 0]$$

$$V_{dc} = \frac{2\sqrt{2}V_s}{\pi}$$

since required maximum $V_{dc} = 15V$

$$V_s = \frac{V_{dc} \times \pi}{2\sqrt{2}} = \frac{15 \times 3.142}{2\sqrt{2}}$$

$$V_s \cong 17V, \quad V_p = \sqrt{2}V_s$$

$$V_p \cong 24V$$

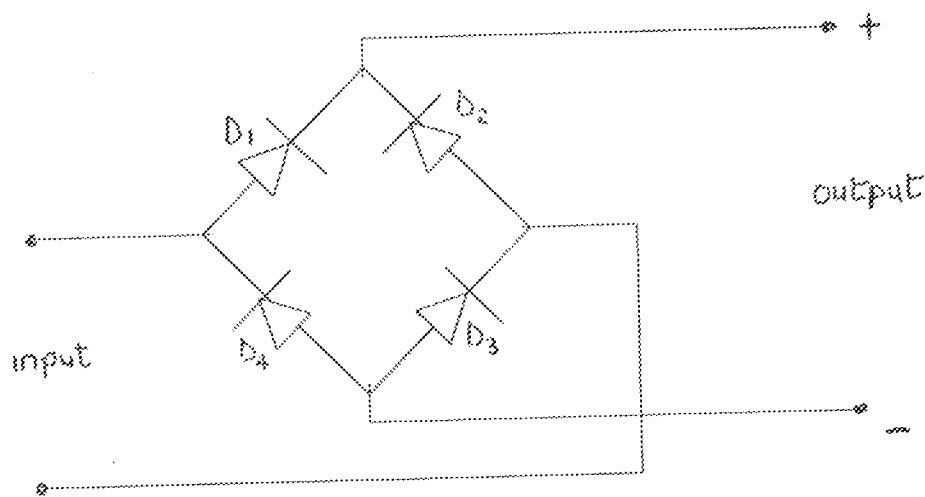

FIG 2.2 BRIDGE RECTIFIER CIRCUIT

The bridge rectifier as shown in fig 2.2 has a forward voltage drop of 0.7V per diode.

Therefore, for every half cycle of the input voltage there will be a drop of 1.4V across the bridge rectifier. This is put into consideration in determining the transformer secondary voltage. A single package bridge rectifier is selected over single diode connection so as to conserve space on the vero board during construction.

$$V_{dc} = \frac{2(V_p - V_d)}{\pi}$$

where V_d is diode forward drop

$$V_p = \frac{(15 \times 3.142) + 2 \times 0.7}{2}$$

$$V_p = 24.25V \text{ and } V_s = 17.15V$$

The secondary voltage of the transformer must be greater than 17.15V so as to get a maximum output d.c voltage of 15V. for transformer input at 240Vac, turns ratio will be

$$n = \frac{V_{primary}}{V_{secondary}} \quad n = \frac{240}{17.15} = 13.99$$

$$\approx 14$$

A transformer rated 240V to 15V is ideal but a major design problem is the a.c mains variation usually encountered on Nigeria. A.c mains supplies is sometimes as slow as 180V, and, with this kind of voltage at the input of transformer rated at 240V to 15V, the required transformation for minimum Vs will not be achieved.

A worst case designed is given below.

$$\text{If input to transformer} = 180V$$

$$n = \frac{180}{17.75} = 10.49$$

$$\text{For 240V input, } V_s = \frac{240}{10.49} \cong 23V$$

For a turns ratio of 10.49 at the standard a.c input of 240V, a transformer of 23V rating at the secondary is suitable, but a center taped transformer rated at 240/25V was chosen so as to achieve a dual polarity output.

Diode selection.

The diode peak inverse voltage (PIV) for a bridge rectifier is equal to its peak voltage- V_p . But since a center tap transformer was chosen, the bridge PIV should be greater than or equal to $2V_p$

$$PIV \geq 2V_p$$

$$\text{If } V_p = \sqrt{2} \times 25 = 35.35V$$

$$PIV \geq 35.35 \times 2$$

$$PIV \geq 70.7V$$

A bridge rectifier rated at 100V, 4A was chosen.

Filter capacitor

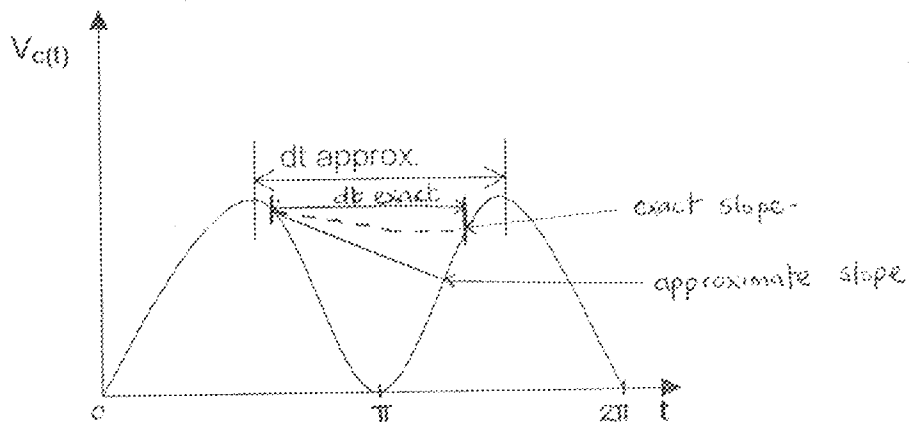

Figure 2.3 OUTPUT WAVEFORM OF FILTER CAPACITOR

For a capacitor,

$$I = C \frac{dv}{dt}$$

dv - ripple voltage

dt - time during which the capacitor discharges

I - current taken out of the supply

Assumptions

- i. I_{out} is constant at its maximum value
- ii. Capacitor is discharged for the full time between peak

$$\text{If } I_{out} = 1.5A$$

dt is half the period of the 50Hz input waveform

$$dt = \frac{1}{2f} = \frac{1}{2 \times 50}$$

$$dt = 10ms$$

For a specified ripple of not more than 2V

$$C = \frac{1.5 \times 10 \times 10^{-3}}{2}$$

$$C = 7500\mu F$$

A smaller value of capacitor was chosen 2,500 microFared capacitor rated at 35V is suitable and this is because I.C regulator has some filtering effect To achieve an output

near a perfect d.c, a 10microFarad capacitor rated at 16V was selected for the regulator output filter.

Regulators

IC regulators were selected based on their functions. Because of the required variable output of the power supply, variable three terminal regulator were selected considering the voltage and current capabilities, the regulator selected has the following specifications and rating.

- i. 1.2V minimum input voltage and 37V maximum input voltage.
- ii. 1.5A maximum output current.

Figure 2.4 shows the basic circuit connection of the regulator.

V reference for regulator is given by $V_{ref} = 1.25V$
while adjust current is given as $I_{adj} = 100\mu A$

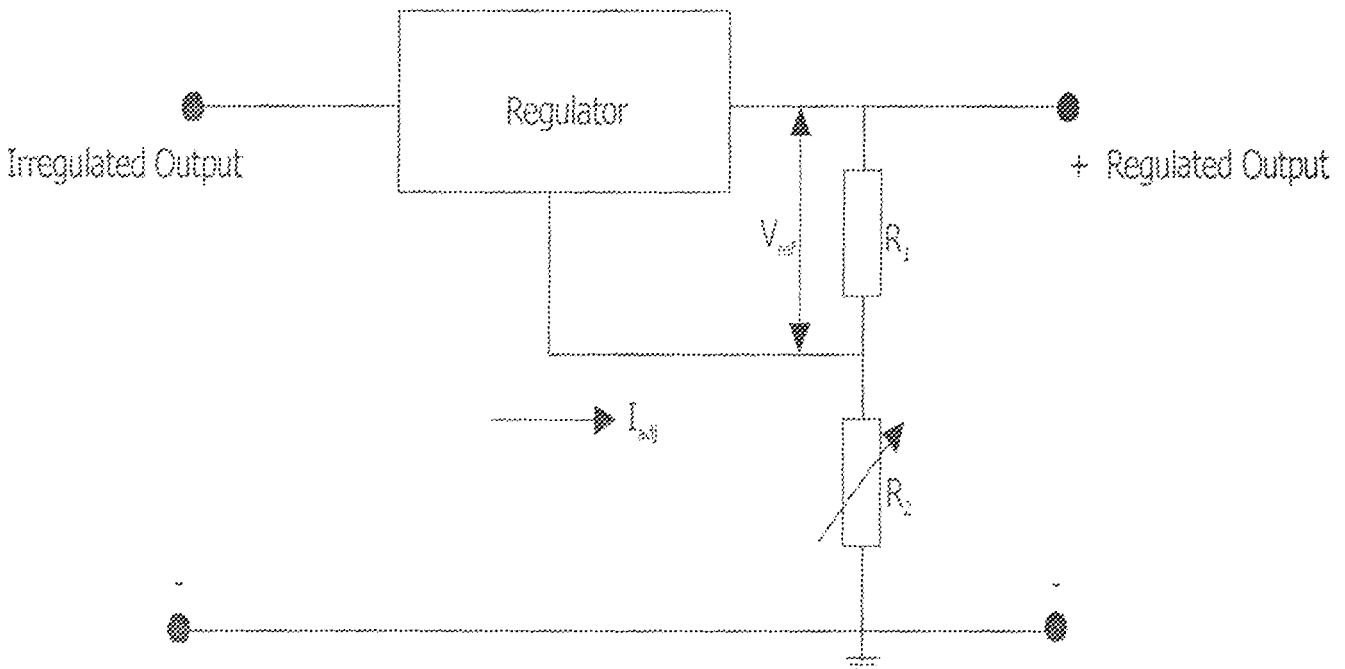

FIG 2.4 REGULATOR CIRCUIT CONNECTION

Output voltage from regulator is given by

$$\text{Output voltage } V_o = V_{ref} \left(1 + \frac{R_2}{R_1} \right) + I_{adj} R_2$$

Resistor R_2 is a potentiometer, therefore a value can be fixed for it.

$$\text{Let } R_2 = 5k\Omega$$

For a maximum V_o of 15V

$$15 = 1.25 \left(1 + \frac{5k}{R_1} \right) + 100 \times 10^{-6} \times 5k$$

$$15 = 1.25 + \frac{6250}{R_1} + 0.5$$

$$R_1 = \frac{6250}{13.25} \cong 471.69\Omega$$

Δ 500 Ω , $\frac{1}{4}$ W resistor was selected.

Fuse rating.

The transformer steps down voltage from 240V to 25V. Therefore current steps up proportionately.

$$\frac{V_1}{V_2} = \frac{I_2}{I_1}$$

$$\frac{240}{25} = \frac{I_2}{I_1}$$

$$9.6I_1 = 3000mA$$

$$I_1 = 313mA.$$

V_1 – Input voltage to transformer

V_2 – Output voltage from transformer

I_1 – Input current to transformer

I_2 – Output current from transformer

There is heating effect in the transformer, which is caused by recharging of filter capacitor during only a part of the full cycle. The fuse rating is selected putting in mind two important factors.

- Current surges
- No blow under normal full load.

$$\begin{aligned} \text{Fusing rating (current)} &\approx 313\text{mA} \times 4 (\text{for current surges}) \times 2 (\text{not to blow under fullload}) \\ &\approx 2.5\text{A} \end{aligned}$$

A 2.5A slow blow fuse is selected to protect the transformer input.

ANALOG TO DIGITAL CONVERTER

The A/D converter is a display type, and it is known as a digital voltmeter. The method of conversion employed in this converter is the dual slow integration.

The major deciding factor for the selection of this IC converter is the limited external circuitry. It needs only ten external passive component plus four single seven segment displays to make an accurate 3 1/2—digit panel meter. The input voltage range to this A/D converter is limited to 0 to 0.2V; therefore, a voltage divider is used to extend the range to about 20V.

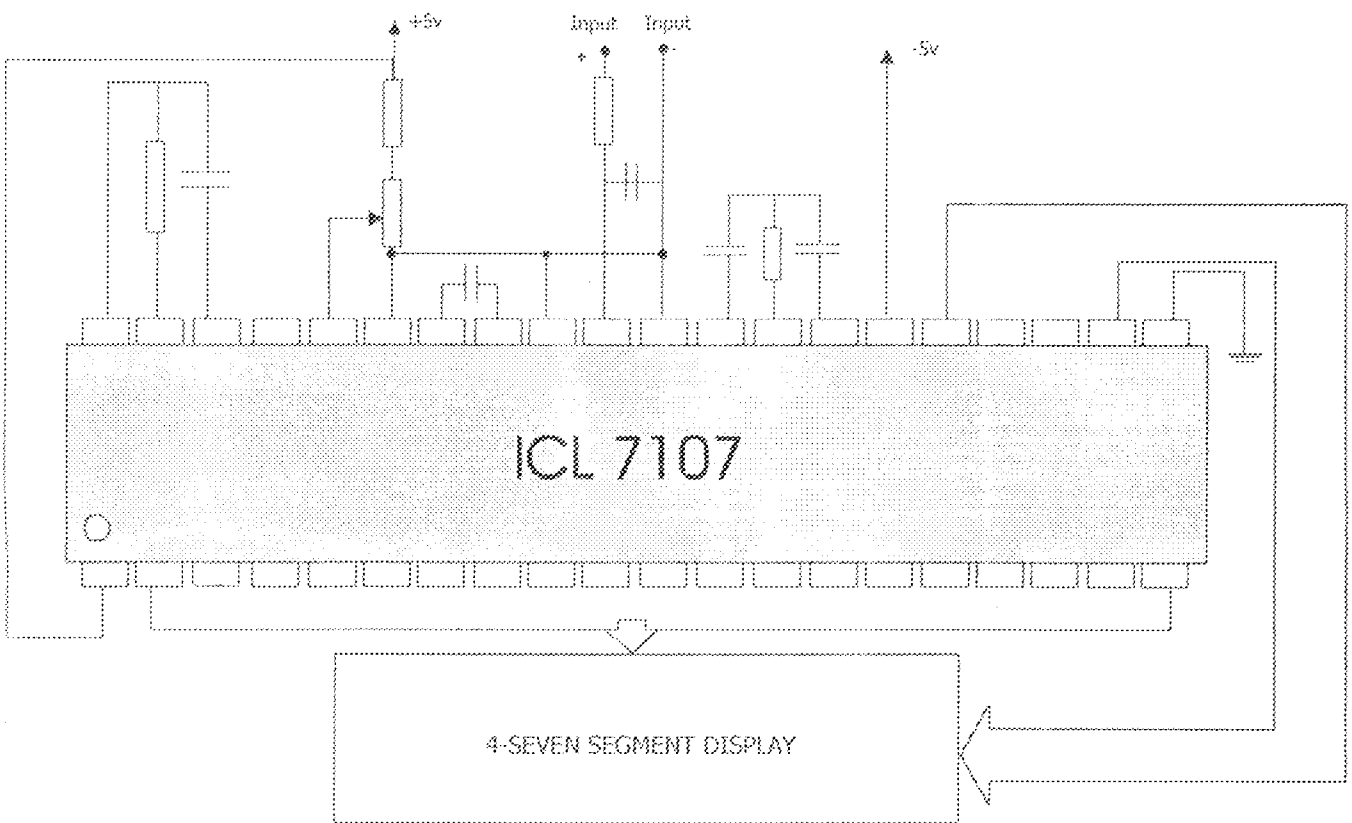

FIG. 2.5 ANALOG TO DIGITAL CONVERTER

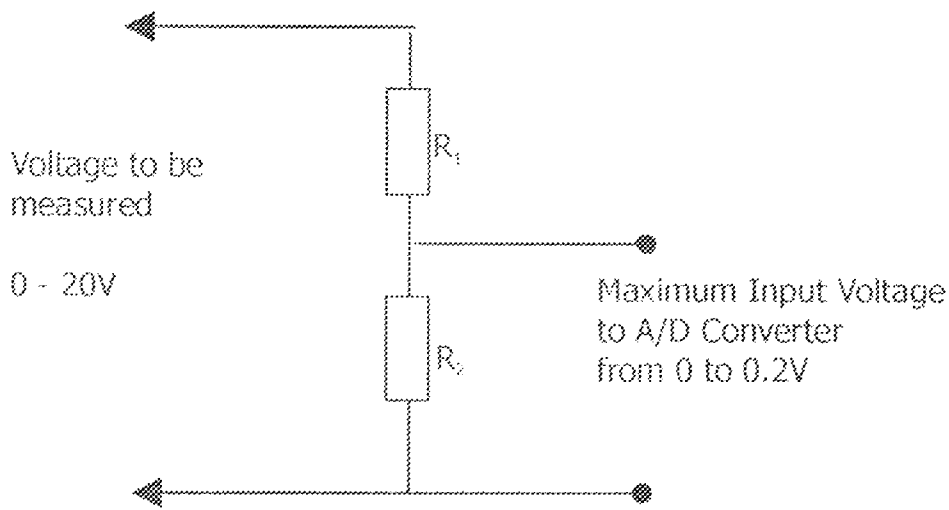

FIG. 2.6 VOLTAGE DIVIDER CIRCUIT

The resistors could be scaled by 100. Let $R_1 = 100k\Omega$

$$0.2 = \frac{R_2}{R_1 + R_2} \times 20V$$

$$0.2 = \frac{20R_2}{100k + R_2}$$

$$R_2 = 1k\Omega$$

$$R_2 = 1k\Omega$$

$$R_1 = 100k\Omega$$

SEVEN SEGMENT DISPLAYS

All the seven segment displays used in the system design and construction are 14 pin DIP IC and are connected in the common anode mode.

The displays are powered from a +5V supply. Typical LEDES can accept only about 1.7 to 2.1V across their terminals when lit, so, limiting resistors are connected in series to the segments terminals with the exemption of the A/D converter displays. Maximum specified current for the displays determines value of limiting resistor.

$$I_{max} = 25mA$$

$$R_{limiting} = \frac{5V}{25mA}$$

$$R_{limiting} = 200\Omega$$

150 Ω resistors were selected.

2.2 FUNCTION GENERATOR

WEIN BRIDGE OSCILLATOR

The frequency of oscillation of the circuit in figure 2.7 is determined by finding the feedback fraction

$$\beta = \frac{Z_A}{Z_A + Z_B}$$

$$\text{where } Z_A = \frac{R_A \times \frac{1}{j\omega C_A}}{R_A + \frac{1}{j\omega C_A}}$$

$$Z_B = R_B + \frac{1}{j\omega C_B}$$

$$\beta = \frac{\omega R_A C_B}{\omega R_A C_B + \omega R_B C_B + \omega R_A C_B + j(\omega^2 R_A R_B C_A C_B)}$$

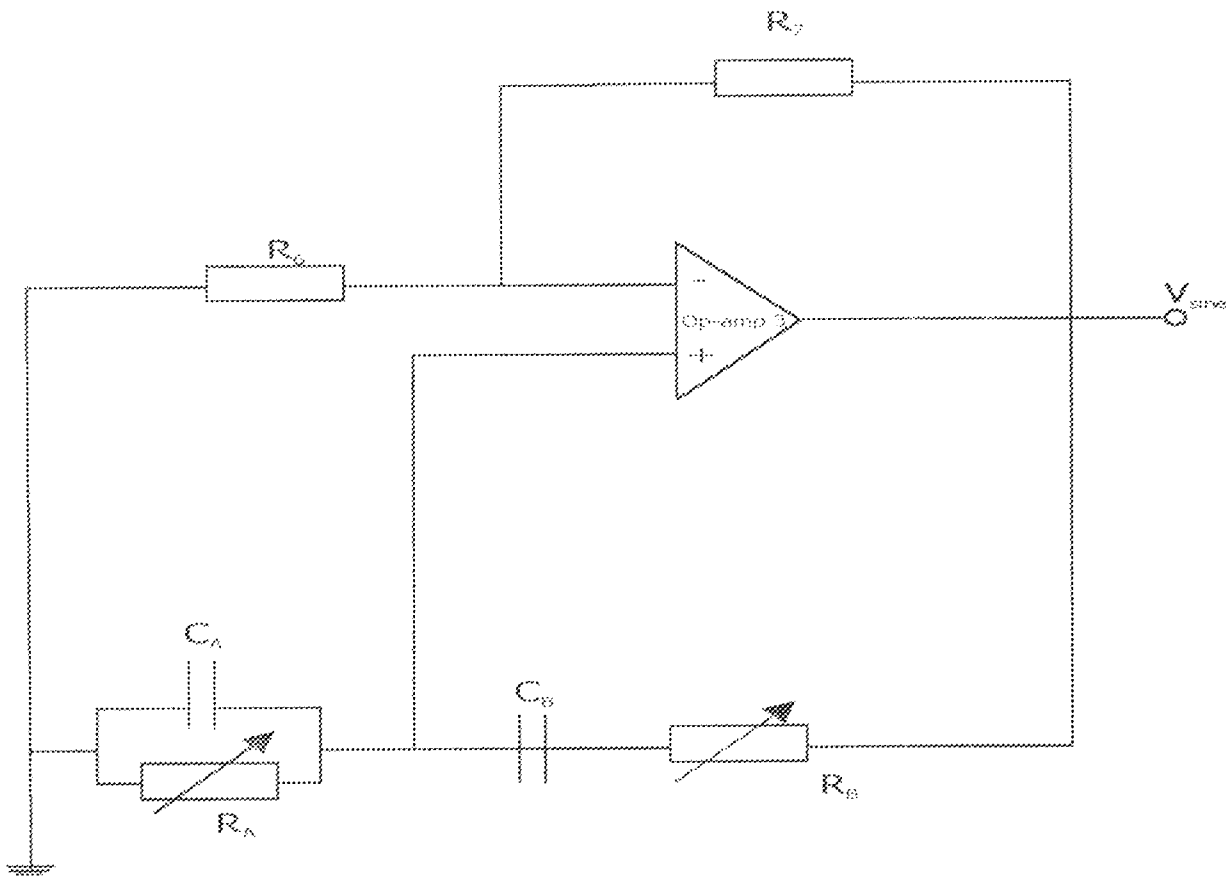

FIG. 2.7 WEIN BRIDGE OSCILLATOR CIRCUIT

In order to meet the phase shift condition for oscillation β must be a real quantity. Therefore, imaginary part of the denominator must be zero.

$$\omega^2 R_A C_A R_B C_B - 1 = 0$$

$$\omega^2 = \frac{1}{R_A C_A R_B C_B}$$

where $\omega = 2\pi f$

let $C_A = C_B = C$ and $R_A = R_B = R$

$$\text{then } 2\pi f = \frac{1}{RC}$$

if f_0 is the frequency of oscillation

$$f_0 = \frac{1}{2\pi RC}$$

The value of f in equation (2) is substituted into equation 1 to determine the value of

$$\beta = \frac{2\pi f RC}{3(2\pi f RC) + j(4\pi^2 f^2 R^2 C^2 - 1)}$$

$$\beta = \frac{1}{3 + j(1 - 1)} = \frac{1}{3}$$

For oscillation to occur, the magnitude of the loop gain must be equal to unity, that is

$$|A\beta| = 1$$

If amplifier gain for non-inverting connection is given as

$$A = 1 + \frac{R_7}{R_6}$$

and $|A\beta| = 1$, then A must be equal to 3.

$$3 = 1 + \frac{R_7}{R_6}$$

$$2R_6 = R_7$$

R_{\max} which is the maximum value of gang resistor will be achieved at the minimum output frequency.

$$R_{\max} = \frac{1}{2\pi f_{\min} C}$$

$$R_{\max} = \frac{1}{2 \times 3.142 \times 1 \times 10000 \times 10^{-12}}$$

$$R_{\max} = 15.9 \text{M}\Omega$$

R_s and C_s in figure 2.8 form the filter circuit of the amplitude stabilizer. The product of R_s and C_s should be sufficiently large in order to hold the peak with negligible charge for a very long interval compared with a period at lowest oscillation period. The lowest oscillation period occurs at

$$T_{\text{lowest}} = \frac{1}{f_{\max}}$$

$$T_{\text{lowest}} = \frac{1}{100 \times 10^3}$$

If $R_s C_s$ must be sufficiently larger than T_{lowest} , for a capacitor value of $0.01 \mu\text{F}$ electrolytic and a resistor value of $100 \text{k}\Omega$

$$R_s C_s = 100 \times 10^3 \times 0.01 \times 10^{-6}$$

$$R_s C_s = 1 \text{ms}$$

therefore $R_s C_s \gg T_{\text{lowest}}$.

Q is a general purpose N-type JFET (2N5457).

2.3 SQUARE AND TRIANGULAR WAVE GENERATOR

From circuit diagram of figure 2.9 a threshold voltage $-V_T$ to $+V_T$ is set up at the non-inverting input of the op-amp and the saturation voltages of the op-amps are

$$\text{Therefore } V_T = \frac{R_3}{R_4} V_{SAT}$$

$$\text{If } R_4 = KR_3$$

$$V_T = \frac{R_3}{KR_3} V_{SAT}$$

$$V_T = \frac{V_{SAT}}{K}$$

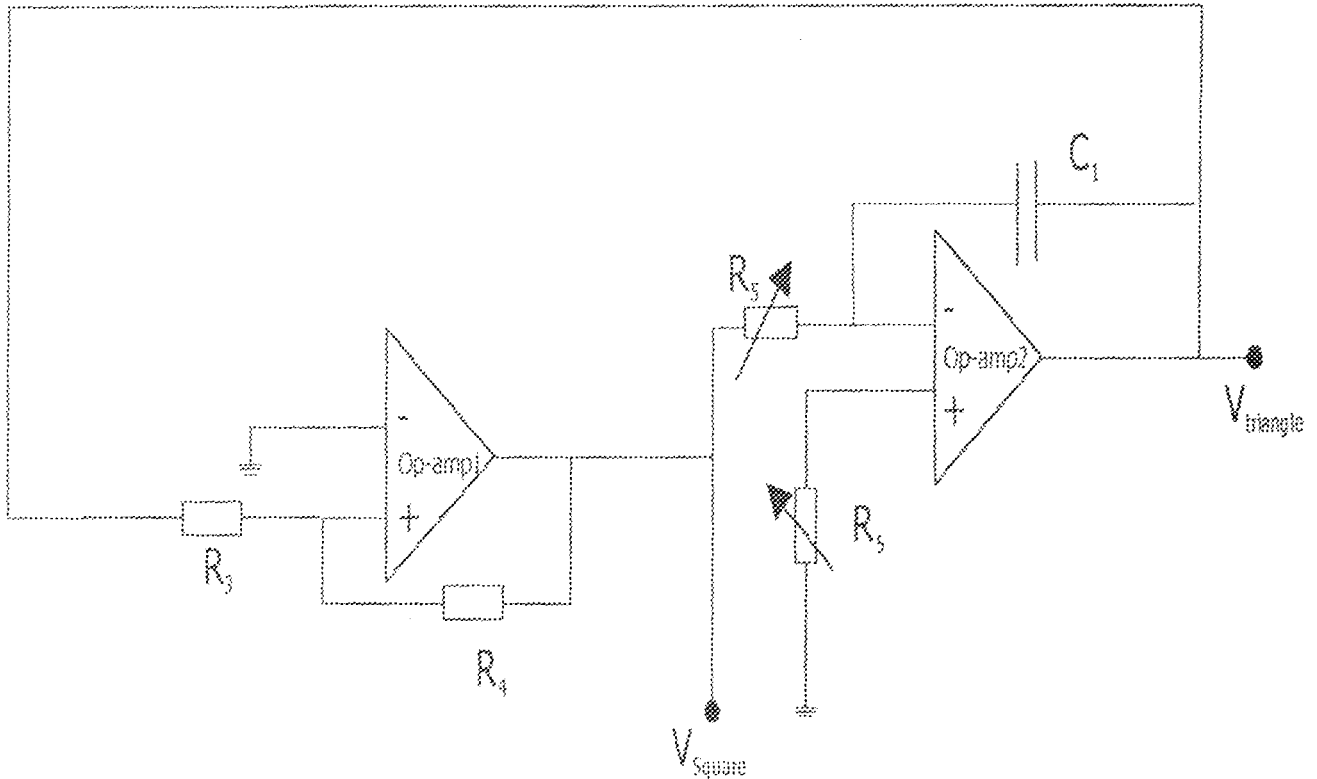

FIG. 2.9 SQUARE/ TRIANGULAR WAVEFORM GENERATOR CIRCUIT

From the output waveforms of figure 2.10, assume at time $t=0$, op-amp/ output is V , and undergoes a negative transition to a level $-V_{SAT}$ as shown in figure 2.10, this means that the output of op-amp2 which is also the input to op-amp1 had just reached a level $-V_T$ as shown in figure 2.10. V_2 would have actually been slightly more negative than $-V_T$ to cause the transition. It is thus reasonable to assume that $V_2(0^+) = -V_{SAT}$, where $V_2(0^+)$ is the initial value of output at time $t = 0$. Thus output $V_2(t)$ of op-amp2 following the transition can be expressed as

$$V_2(t) = -\frac{1}{R_5 C_1} \int_0^t V_1(t) dt + V_2(0^+) \quad \text{equation 2}$$

substituting $V_1(t) = -V_{sat}$ and $V_2(0^+) = -V_T$ into equation 2

$$V_2(t) = \frac{V_{sat}}{R_5 C_1} t - V_T \quad \text{equation 3}$$

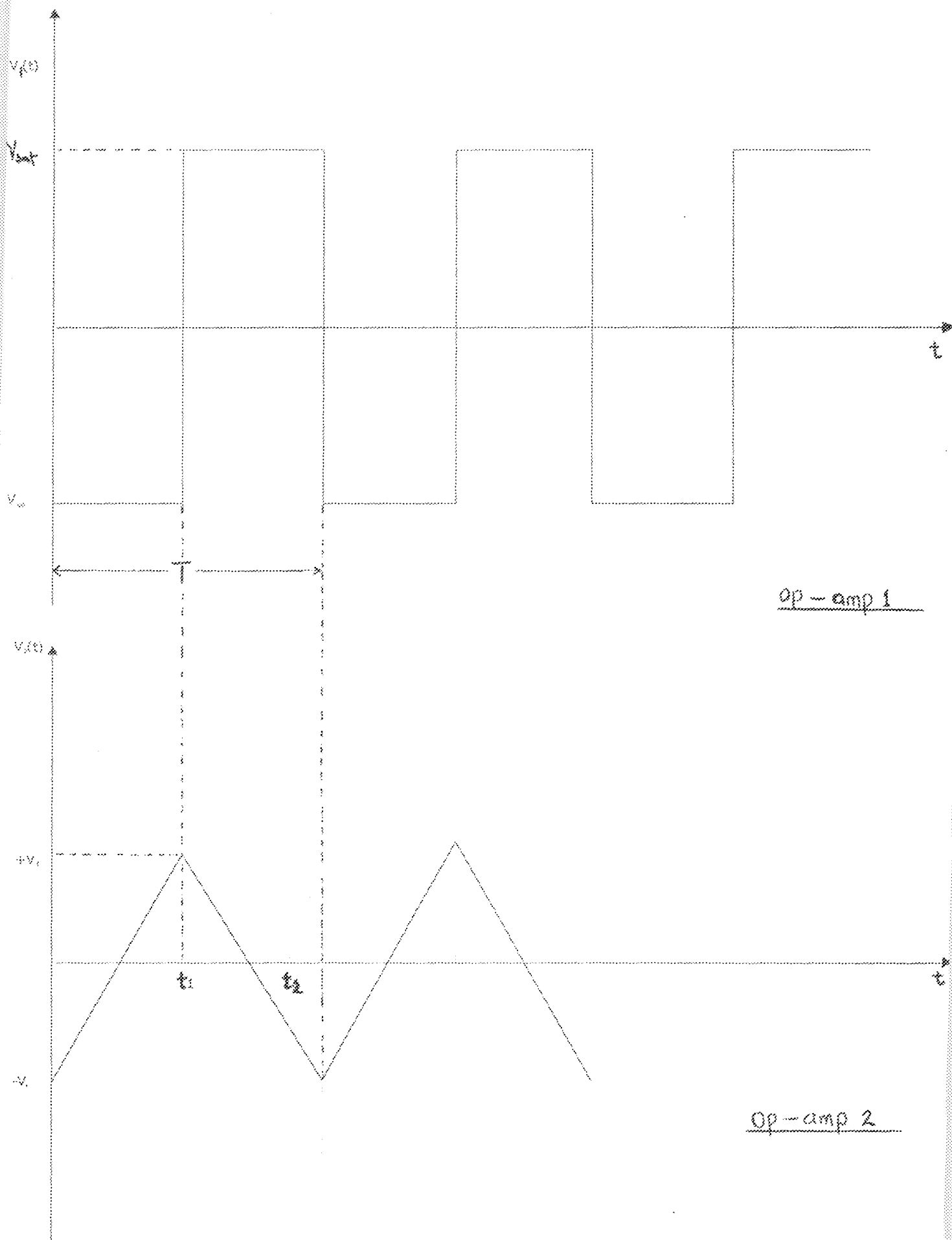

FIG. 2.10 OUT WAVEFORMS OF OP - AMPS 1 AND 2

From equation (3), it is seen that $V_2(t)$ increases linearly from a level of $-V_T$, op-amp1 remains in the low state until V_2 reaches the level $+V_T$. Therefore, let t_1 represent the time at which this is reached

substitute $V_2(t) = V_T$ and $t = t_1$ into equation (3)

$$2V_T = \frac{V_{sat}}{R_5 C_1} t_1$$

$$t_1 = \frac{2V_T R_5 C_1}{V_{sat}}$$

$$\frac{V_T}{V_{sat}} = K \quad \text{from equation (1)}$$

$$\text{therefore } t_1 = \frac{2R_5 C_1}{K}$$

After the transition occurs, the input voltage to op-amp2 now causes the output to decrease linearly as shown in figure 2.10. When $V_2(t)$ reaches the level V_T , op-amp1 output drops to $-V_{SAT}$ and a full cycle is completed. Assuming symmetrical values for saturation voltages, period T can be expressed as

$$T = 2t_1 \\ = \frac{4R_5 C_1}{K}$$

Therefore frequency of operation of the circuit can be obtained.

$$f = \frac{K}{4R_5 C_1}$$

The output frequency is made variable by varying resistors R_5 .

Since the maximum required frequency from this circuit is 100KHZ

Peak output voltage for square wave = $\pm 13V$

Peak output voltage for triangular wave = $\pm 10V$

To determine K

$$K = \frac{V_{sat}}{V_T}$$

where $V_{sat} = 13V$ and $V_T = 10V$

$$K = \frac{13}{10} = 1.3$$

the values of R_3 and R_4 are given by

$$R_4 = KR_3$$

let $R_3 = 10K\Omega$, then $R_4 = K \times R_3 = 13K\Omega$

For a fixed value of $0.1\mu\text{F}$ for op-amp 2 capacitor

$R_{5\text{max}}$ which occurs at f_{min} will be

$$\begin{aligned} R_{5\text{max}} &= \frac{K}{4f_{\text{min}}C_1} \\ &= \frac{1.3}{4 \times 1 \times 0.1 \times 10^{-6}} \\ &= 3.25\text{M}\Omega \end{aligned}$$

$R_{5\text{min}}$ will occur at f_{max}

$$\begin{aligned} R_{5\text{min}} &= \frac{1.3}{4 \times 100 \times 10^3 \times 0.1 \times 10^{-6}} \\ R_{5\text{min}} &= 32.5\text{M}\Omega \end{aligned}$$

2.3 FREQUENCY METER

The frequency meter is designed by using digital circuits. Digital counters formed the major component of the frequency meter. Digital circuit was used because they require little or no external circuitry. Decade counters were chosen so as to have counts from 0 to 9 and the next count resets the counter. All other components were selected based on their availability and circuit connections.

Five decade counters were cascaded so as to have a count of 99,999 which is close to the maximum output frequency required. The clock source is the 555 timer of figure 2.11 and the frequency of operation is determined from

$$f = \frac{1}{0.7(R_A + 2R_B)C}$$

and duty ratio $D = \frac{R_B}{R_A + R_B}$

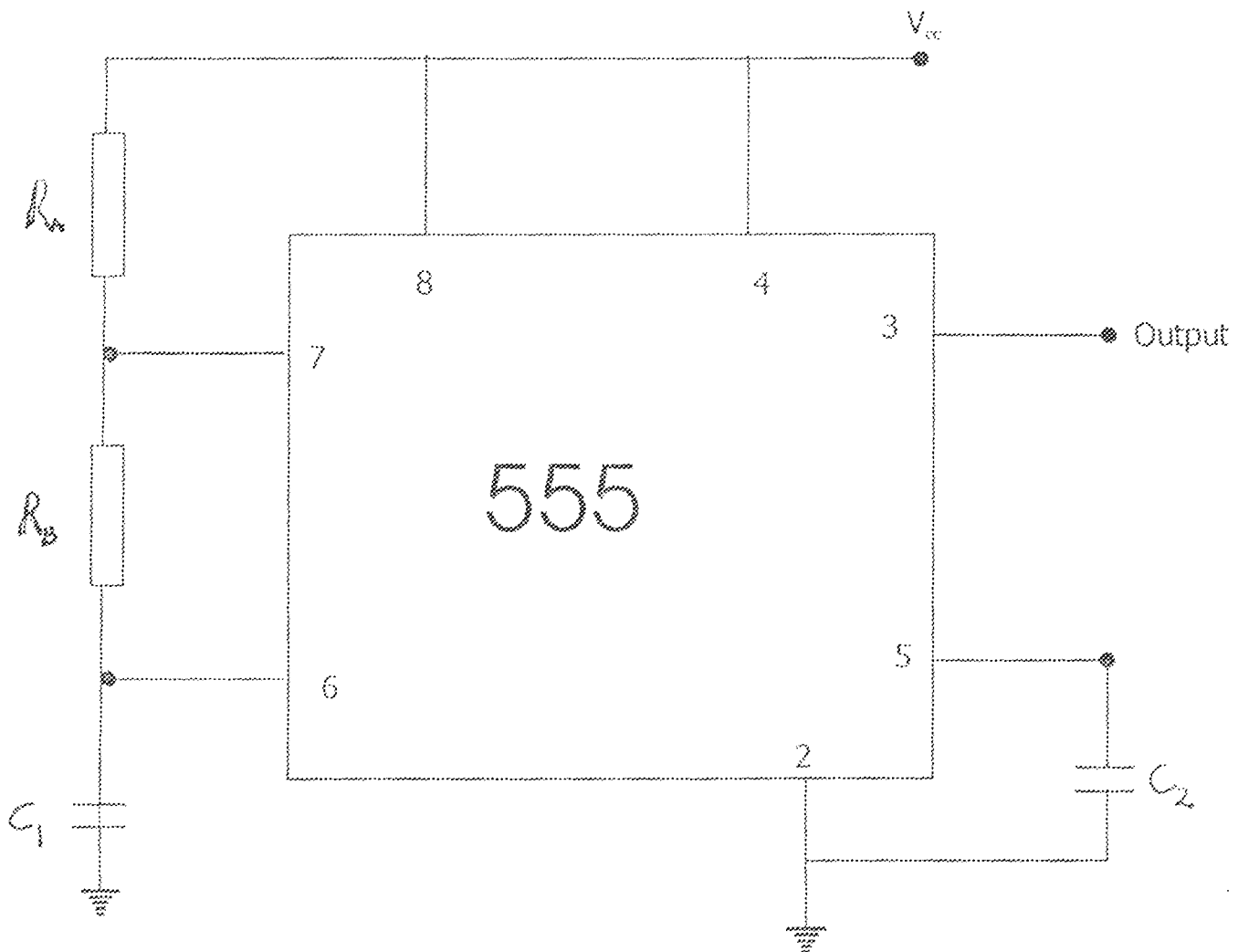

FIG 2.11 555 TIMER

For a clock frequency of 100kHz, $t_{eff} = 1000\mu s$

if D should be 50%, $R_A = R_B$

$$100 \times 10^3 = \frac{i}{0.7(R_A + 2R_B) \times 1000 \times 10^{-12}}$$

$$(R_A + 2R_B) = 14286\Omega$$

This is a good choice as it keeps R_A and R_B in the $k\Omega$ range. There are many ways to select R_A and R_B . One choice, which makes them approximately equal is to set

$$R_A = 5k\Omega \text{ and } R_B = 4.7k\Omega$$

BCD- TO- SEVEN –SEGMENT DECODER/DRIVER

The output of the decade counters are binary coded, therefore, in order to display a decimal equivalent, a counter in the form of BCD to seven segment decoder driver was selected. This converter also has the ability to drive seven segment displays.

TABLE 2.1 TRUTH TABLE OF A BCD TO SEVEN-SEGMENT DECODER

DECIMAL	INPUTS				OUTPUT						
	D	C	B	A	a	b	c	d	e	F	g
0	L	L	L	L	ON	ON	ON	ON	ON	ON	OFF
1	L	L	L	H	OFF	ON	ON	OFF	OFF	OFF	OFF
2	L	L	H	L	ON	ON	OFF	ON	ON	OFF	ON
3	L	L	H	H	ON	ON	ON	ON	OFF	OFF	ON
4	L	H	L	L	OFF	ON	ON	OFF	OFF	ON	ON
5	L	H	L	H	ON	OFF	ON	ON	OFF	ON	ON
6	L	H	H	L	OFF	OFF	ON	ON	ON	ON	ON
7	L	H	H	H	ON	ON	ON	OFF	OFF	OFF	OFF
8	H	L	L	L	ON	ON	ON	ON	ON	ON	ON
9	H	L	L	H	ON	ON	ON	OFF	OFF	ON	ON

L – low input

H – high input

The outputs, corresponds to segments of a seven segment display unit.

LATCHES

Four-bit latches served as temporary buffer memory to the output of the decoder/driver.

This was necessary because counts are cleared by the clear signal after every count, thus making it difficult to ascertain the frequency of a signal being measured.

J.K FLIP- FLOP

The J-K flip-flop is used as a control circuit. It was selected because of its toggling capability. The J and K inputs are connected to the 5V supply. Therefore, any clock input causes the flip-flop to act like toggle switch

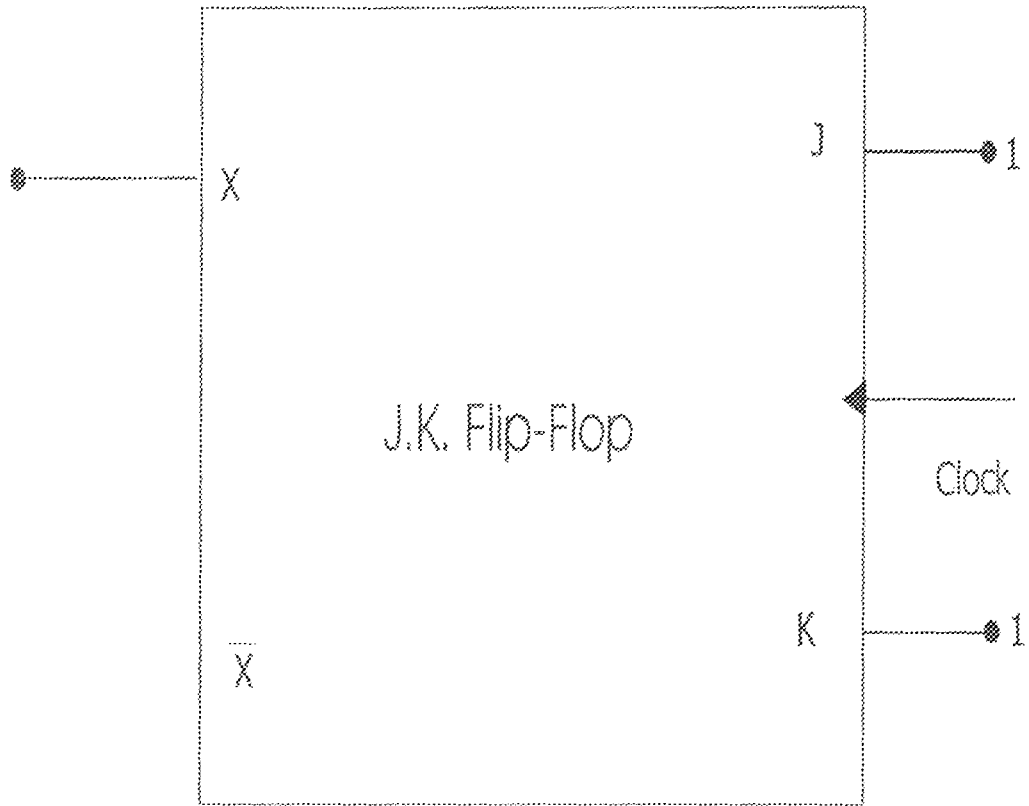

FIG. 2.13 J K FLIP – FLOP CIRCUIT

ONE SHOT

The output of the counter needs to be cleared after every count. Therefore a clear signal that enables the output to be stored in latches on time is required. The one-shot produces an output with a time delay whenever it is clocked. The time delay depends on the RC time constant. The timing of the one-shot, or duration of its output pulse, is determined by the timing resistor and capacitor connected to it. The duration of the output pulse is giving by

$$t_w = 0.7C_1R_1$$

where C_t and R_t are the values of timing capacitor and resistor, respectively. The maximum allowable value for an external capacitor is $1000\mu F$ from manufacturer's specifications.

To determine the value of timing resistor, a value is fixed for capacitor and a desired time is set

$$\text{Let } C = 1000\mu F \text{ and } t_w = 2.5s$$

$$2.5 = 0.7 \times 1000 \times 10^{-6} \times R$$

$$R \approx 3.5k\Omega$$

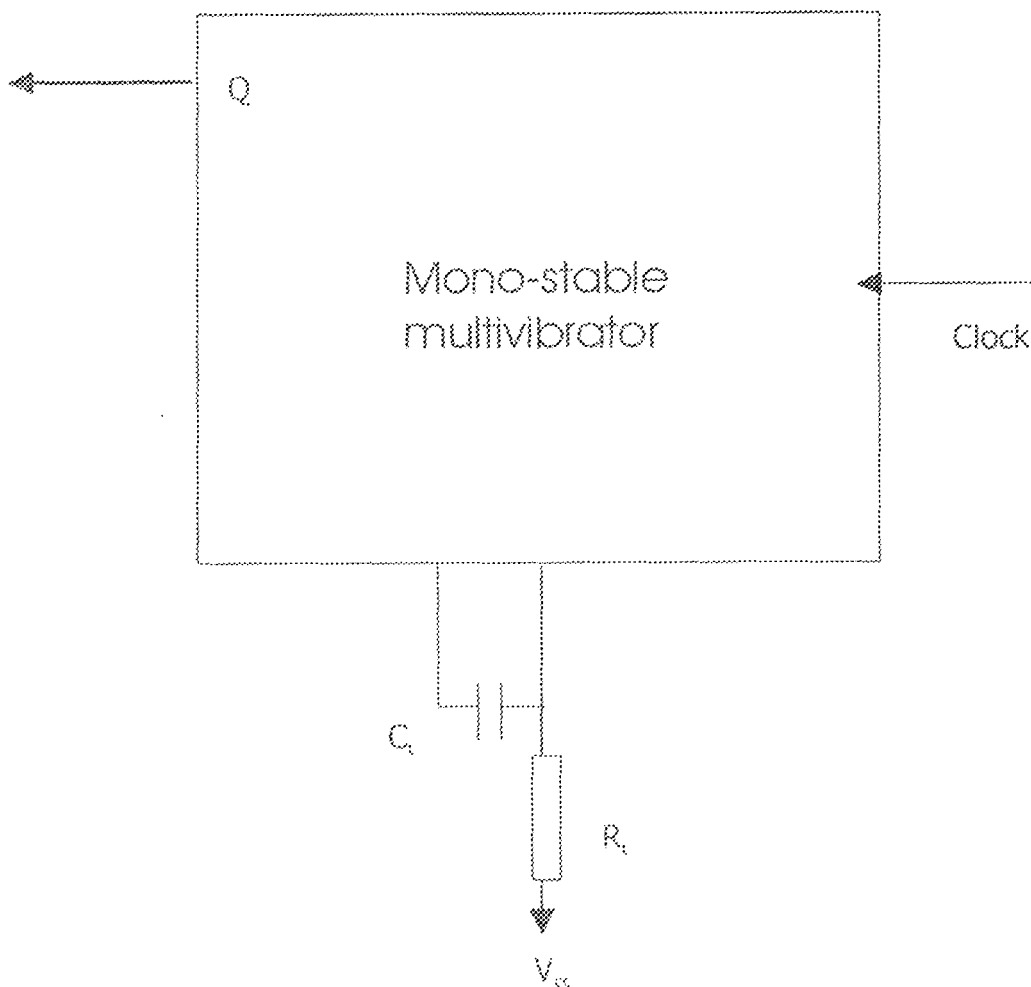

FIG 2.14 MONOSTABLE MULTIVIBRATOR CIRCUIT

SCHMITT TRIGGER

The counter can only count pulses, therefore, it was necessary to use a waveshaping circuit to get pulse equivalent of the sinusoidal waveform. The Schmitt trigger inverter is used to square up the sinusoidal waveform.

3.2 TESTING.

The whole circuit was tested after veroboard soldering. Firstly, all soldered joints were checked to ensure there was no dry joint as well as bridged joints. The circuit was connected to a.c mains and its outputs monitored.

The power supply voltages were measured from the terminals and the desired dual polarity d.c voltages were achieved but these voltages could only vary from 2V to 14.5V. The digital display provided an accurate reading corresponding to the output terminal voltages.

Afterwards, the positive d.c voltage output was used to power a 6V transistor radio for three hours and a satisfactory performance of the power supply unit was recorded.

The function generator produced the desired output waveforms as monitored on an oscilloscope but the maximum output frequency achieved was 60KHz and afterwards distorted signals were produced. The frequency counter output was not very accurate and the counter response was slow, thereby taking a long interval to achieve a steady count.

CHAPTER FOUR

RECOMMENDATION AND CONCLUSION

The project aim is to design and construct an electrical workbench device incorporated with a dual polarity power supply with a digital display unit for output voltage, three output function generator (sine, triangular, and square waveforms.). Lastly a frequency counter with a digital display unit for frequency output. The aim was achieved, but not without limitations and difficulties.

The major limitations are the inability to obtain the maximum desired output frequency, and a slow response to input by the frequency counter. The difficulties encountered were due to improper oscillation of the clock circuit, but this was overcome by the use of a Schmitt trigger. The clock output could also not generate the maximum clock time. The project construction was greatly delayed by failure of major components, which were unavailable in Minna. This added greatly to the total cost of construction of the whole device.

I hereby recommend that the department should propose projects that will be useful in the laboratory as well as in the university community so as to encourage and build confidence in upcoming students. Students should also be made to use projects constructed by fellow students for practical works instead of dumping such project works in the department; this will not make the designer's efforts worthless. The project can be improved on by using a crystal oscillator as the clock generator, and the frequency counter can be made to display fractions. These modifications should be a topic for future project proposals.

REFERENCES

1. ELECTRONIC DEVICES AND CIRCUIT THEORY
BY: ROBERT BOYLESTAD AND LOUIS NASHIELSKY
SIXTH EDITION
PUBLISHED BY: PRENTICE HALL INTERNATIONAL EDITIONS (1996)
2. ELECTRONIC INSTRUMENTS AND MEASUREMENT TECHNIQUES
BY: F.F MAZDA
PUBLISHED BY: PRESS SYNDICATE OF THE UNIVERSITY OF CAMBRIDGE
(1987).
3. ELECTRONIC DEVICES AND CIRCUITS
BY: JACOB MILLMAN AND CHRITOS C. HALKIAS
PUBLISHED BY: MCGRAW-HILL INTERNATIONAL EDITIONS
(1997).
4. OPERATIONAL AMPLIFIERS WITH LINEAR INTEGRATED CIRCUITS
BY: WILLIAM D. STANLEY
SIXTH EDITION, PUBLISHED BY: MERRILL PUBLISHING COMPANY.
5. HANDBOOK OF MEASUREMENT SCIENCE (VOLUME 2)
EDITED BY: P.H SYDENHAM
PUBLISHED BY: JOHN WILEY AND SONS LIMITED (1983).