

**DESIGN AND CONSTRUCTION OF AN
AUTOMATIC PHOTO-SENSITIVE
EMERGENCY LAMP WITH SECURITY
ALERT SYSTEM**

BY

TITILOYE TAYO DORCAS

99/8388EE

**DEPARTMENT OF ELECTRICAL AND COMPUTER ENGINEERING
SCHOOL OF ENGINEERING AND ENGINEERING TECHNOLOGY
FEDERAL UNIVERSITY OF TECHNOLOGY MINNA**

NOVEMBER, 2005

DECLARATION

I here by declare that this thesis, presented in partial fulfillment of the requirement for the award of Bachelor degree in Electrical and Computer Engineering (B.Eng) is a complete handiwork of Titiloye Tayo Dorcas.

Information obtained from both published and unpublished works of others have been acknowledged accordingly.

CERTIFICATION

This is to certify that the project work titled "Design and construction of an automatic photo-sensitive emergency lamp with security alert system" was carried out by Titiloye Tayo Dorcas, under the supervision of Mrs Alenoghena C.O and submitted to the Electrical and Computer Engineering Department of the Federal University of Technology, Minna in partial fulfillment of the requirement for the award of Bachelor of Engineering (B.Eng) Degree in Electrical and Computer Engineering

Mrs Alenoghena C.O

Project Supervisor

.....

Head of Department

.....

External Examiner

Alenoghena 5/12/05

Signature and Date

[Signature]
5/12/05

Signature and Date

.....

Signature and Date

ACKNOWLEDGEMENT

I am most grateful to first of all, God the giver of life and sustenance of destiny for keeping me through this work and my stay in school.

I am also unreservedly thankful for the guidance of my supervisor, Mrs Alenoghena C.O and her uncompromising stand for Hardwork and excellence. Her accessibility, simplicity and approach to work is a model worthy of emulation.

Special thanks go to my parents Dr. and Mrs. E.O Tiiloye for their financial and moral support throughout the duration of my course. To my siblings: Tope, Yinka, Tolu, Tola , you have added spice to my life.

I am also grateful to Prof. and Mrs F.O Akinbode for their love and support.

I cannot forget to mention my wonderful friends: Tomi, Alex, Hangem, Joe, Kemi, Dipo, Samuel, Busayo, Seye, Toyin, Folorunsho, and Stephen thanks for being there for me. You have made life a lot easier. To Wale Kehinde, thanks for your great input into this work, you have made my last stay in this school beautiful. God will reward you richly. Lastly, to Adeleke Adetunji for your love and support. You make life beautiful for me.

Once again all honour, and adoration be to the Great and mighty God who makes all things possible.

DEDICATION

This project is dedicated to the Lord God Almighty, the only wise God for His abundant grace and faithfulness throughout my stay in school.

I also dedicate this to my wonderful parents Dr. and Mrs. E .O Titiloye for their love and total support.

ABSTRACT

The aim of this project is to design, construct and test an emergency lighting system with security alert that serves as an alternative source of light and also as a security measure in residential buildings.

It has a wide range of uses which includes places like corridors, stairwells, escalator, aisles and exit passage ways. It provides safe exits from suddenly darkened building areas. It illuminates exits and directional signs, plays an exceptional role in risk redirection. It also serves as an intrusion alarm needed in homes.

The system was designed using a rechargeable battery, which receives sufficient charge from the AC source of power to maintain them in a fully charged state. The circuit uses a light sensor (photo diode) which senses darkness. Its resistance can be as low as 80 ohms in bright light and in darkness, the resistance increases to 1M ohm.

It was designed constructed and tested to work perfectly well and at an affordable price.

LIST OF TABLES

| Table | Description | Page |
|-------|-----------------------|------|
| 3.1 | Flip-Flop Truth Table | 24 |
| 3.2 | AND gate Truth Table | 26 |
| 3.3 | OR gate Truth Table | 26 |
| 4.1 | Bill of Quantities | 34 |

TABLE OF CONTENTS

| | |
|--|------|
| Title Page | i |
| Declaration | ii |
| Certification | iii |
| Acknowledgement | iv |
| Dedication | v |
| Abstract | vi |
| List of tables | vii |
| Table of contents | viii |
| | |
| CHAPTER ONE | |
| 1.0 Introduction | 1 |
| 1.1 Lighting | 2 |
| 1.2 Project Objective | 3 |
| 1.3 Methodology | 3 |
| | |
| CHAPTER TWO | |
| 2.1 Early Artificial Illumination | 5 |
| 2.2 Electrical Lighting | 7 |
| 2.3 Present Day Lightin Devices | 8 |
| 2.4 Types of Emergency lighting system | 9 |
| 2.5 Block Diagram and Principle of Operation | 10 |

CHAPTER THREE

| | | |
|-----|---------------------------------|----|
| 3.0 | Theory and Design Analysis | 15 |
| 3.1 | Design of the Power Supply Unit | 15 |
| 3.2 | Design of the Comparator | 20 |
| 3.3 | Design of the Oscillator | 21 |
| 3.4 | Design of the Flip-Flop | 24 |
| 3.5 | Design of the Light Sensor | 24 |
| 3.6 | Design of the Control Unit | 25 |
| 3.7 | Design of the Audio Alarm | 26 |
| 3.8 | Design of the Inverter | 27 |

CHAPTER FOUR

| | | |
|-----|----------------------------------|----|
| 4.0 | Construction, Testing and Result | 30 |
| 4.1 | Testing and Result | 32 |
| 4.2 | Problems Encountered | 33 |

CHAPTER FIVE

| | | |
|-----|-------------------------------|----|
| 5.0 | Conclusion and Recommendation | 36 |
| | Reference | 37 |

CHAPTER ONE

1.0 INTRODUCTION

With the advent of the industrial revolution, automatically controlled devices replace many jobs that were once done manually. The need for automated systems has long been a civilized idea. This requires minimal efforts to accomplish a Herculean task. As a part of automation, control circuits have to be designed to replace manual devices.

The design and construction of an automatic photo-sensitive emergency lamp with security alert system was considered and required based on the numerous benefit it will provide for its' prospective users, especially in a society like ours where the abnormalities in power supply and insecurity of lives and properties are paramount, and of great concern.

The emergency lamp provides an alternative light when there is power failure. The security alert system serves as a security measure in residential buildings. It also notifies when there is power outage. The battery (rechargeable) in the lamp converts energy to be used in the event of power failure.

It has a wide range of uses which includes places like corridors, stairwells, escalators, aisles, and exit passageways. It provides safe exit from suddenly darkened areas. It illuminates exit and directional signs, plays an essential role in risk redirection. The circuit serves as an intrusion alarm which is needed in homes, commercial centers and other places.

Mostly, in this part of the world, or other third world countries where constant supply of power cannot be generally ensured, the need by ordinance for such places and locations mentioned above to have emergency lighting system is not supposed to be taken at a low ebb, because of the number of lives usually involved in accidents due to power

failures. Thus the emergency lighting is supposed to be planned, installed and maintained to the highest standard of reliability.

1.1 LIGHTING

Quality light is a critical and often unrecognized tool in community development. There are an estimated two billion people in the world who rely on inferior lighting systems (i.e. kerosene wick lamps) and pay far more per unit of light than those in the developed world.

High quality lighting technologies are available at affordable prices for all types of lighting systems. One of which is rechargeable power supply. It is a cost effective power source for many lighting energy requirements.

There are several general categories of lighting. Each requires different types of light and often, different types of lamps (also called luminaries)

Lighting can be divided into three general categories, broadly described by the amount of light provided.

Ambient lighting — provides a minimum amount of illumination for people to see each other and to move about.

General lighting- provides enough illumination for reading or viewing objects

Task lighting- provides bright light enough for close work and viewing details.

The project uses the photodiode as a light sensor. In bright light, the resistance of the photodiode can be as low as 80Ω and in darkness the resistance of the photodiode increases to about one mega ohm (1 M Ω). The 4060B IC is a square wave generator. The output waveform is initially low and goes high at 50% of the time at the output pin needed. The pulse generated supplies the control unit which in turn gives low voltage or

c) Design and construction of an automatic night activated light (98/7167EE) by Olatunji Shehu-Lukman Olalekan of the department of electrical /computer engineering, FUT Minna.

CHAPTER TWO

LITERATURE REVIEW

One major priority of human consciousness is visibility. Once men struggled to break the blanket of night with a flickering torch or the small fluttering flame of an oil lamp. Even so, it was not always easy to have light. Lighting or artificial illumination as opposed to the natural illumination of the sun or moon, was probably first furnished by campfires and by torches made of wood. Crude stone lamps in which light came from a flaming work lying in a pool of oil or melting grease were used by prehistoric people.

Candles and oil burning lamps remained the chief source of artificial illumination until the middle of the 19th century, when kerosene lamps with flat woven wick and glass chimney came into common use [1]. A few of these first artificial source of light are discussed below.

2.1 EARLY ARTIFICIAL ILLUMINATION

2.1.1 THE TORCH

The earliest lighting came from wood fire. Men learnt that torches dipped into animal fats lasted longer and gave a stronger light. Torches were for many years. About the year A.D 450, tarred torches were used to light the streets of Antioch [1]. Torches like these were still used in the middle ages.

2.1.2 OIL LAMPS

The first oil used in these early lamps came from animals. The first oil lamp was open stone dishes with wick reeds or plant fibre. These gave light used by the cavemen when they painted pictures deep in caves. Lamps have been used from as long as 3000B.C [1]. Some of these early were from shells or from the skull of small animals. They have a perfect shape for holding a good amount of oil and for supporting a wick

2.1.3 CANDLES

The first candle was stalk filled with beeswax from beehives. The ancient Egyptian had wickless candles made of lumps of tallow wrapped with rags to keep them from melting apart when they burned. The Romans used candle made with wicks. Candles are made in decorative styles and colours. Some in glass containers are used for religious purposes. These are three or four inches in diameter and burns for hours [2]. Some candles are as tall as ten feet and last for years.

2.1.4 LANTERNS

In the 5th century B.C., protective cases for light lanterns were commonly used. Lanterns were designed in many different shapes. Cylindrical lanterns and square types with conical tops were popular. They were made of many materials such as: metal, wood e.t.c

2.1.5 KEROSENE LAMPS

Before 1859, the best lamp oil that money could buy was whale oil. Unrefined petroleum had been used in lamps for many years, but a feeble and dirty flame [2]. In that same year, a great quantity of petroleum oil was discovered in Pennsylvania.

At first, kerosene burned in open lamps. The open flame flickered and was dangerous to use. Then, glass chimney was made for the lamps. The flame became steady and gave more light. With the glass to protect it from the wind and a little roof to protect it from the rain. Kerosene lamps could be used outdoors for street light [1].

Kerosene gave a better light than had ever been known before. Kerosene lamps have flat wicks. By the turn of a small knob, the wick could be raised and lowered and the light could be adjusted. This has a great advantage over other lighting.

2.2 ELECTRIC LIGHTING

In the emergence from the Stone Age, electric lighting has been developed in so many ways that it plays a part in nearly every activity of man. The study and practice of electric lighting has become a profession in itself. The first electric lights are discussed below.

2.2.1 INCANDESCENT BULB

During the 1840s, many experiments aimed at the development of a workable electric incandescent lamp were conducted. In 1879, Thomas Alva Edison, developed a carbon filament incandescent lamp [2]. Edison passed an electric current through thin filament of carbonized thread that were tightly sealed inside a glass bulb from which all air had been removed by a vacuum pump. Edison's invention marked the birth of electric lighting and the electric age.

2.2.2 ELECTRIC ARC LAMPS

Electric arc lamps consist of electrons drawn between two carbons electrodes were one of the earliest lighting devices to make use of electrical energy invented around 1801[3].

2.2.3 DISCHARGE TUBES

Fluorescent light belong to the group of lighting devices known collectively as discharge tubes: glass tubes filled with metal vapour, with electrodes at both ends. Electric current that is passed between the electrodes eventually ionizes the vapour which begins to glow, producing light. Some discharge tubes emit flashes of high intensity light and are used in lighthouses and for directional beacon of various kinds [3].

2.3 PRESENT DAY LIGHTING DEVICES

Thomas Edison perfected the electric bulb in 1897 and his technical genius created the central power station concept in 1880 [4]. Also frank J. Sprague worked with Edison and produced efficient electric generators as a means of supplying his lamps with electric current. George Westinghouse and William Stanley believed in the alternating current concept and developed the commercial practical transformer between 1885 and 1886[4].

For over a century, mankind had depended on electric lighting which is driven by current from electric power generation, to the extent that we can now hardly withstand life or survive life without it. More so, electric lighting is been used everywhere. It is estimated that half of the people of the world suffer the inconsistency of these electric generators due to their failures. As a result of this, an alternative method for generating electric current for lighting system was developed. Thus, a storage facility (battery) was used to provide electricity for use at night.

These batteries are able to store large amount of electrical energy when ~~charged and~~ discharge when put to work. This enhancement has led to the designing of buildings so that people working in them have abundant light without glare. Also due to an alternative power supply when there is no main supply, all sorts of tasks can be done at anytime such as;

- a) a surgeon can operate, if necessary in the middle of the night as easily as he will do in the daytime.
- b) It can ease reading at night.
- c) People can walk safely on stairwells without bumping into things at night when there is a sudden cut off of power supply.
- d) People can sleep with their mind at rest when an alarm is incorporated.

With all the above instances sited, emergency tasks can be done at night when light is available.

2.4 TYPES OF EMERGENCY LIGHTING SYSTEM

There are different types of emergency lighting system of which are:

2.4.1 STANDBY POWER SOURCE

It consist of a battery charger used to keep the battery on full charge, a battery connected to the inverter (dc to ac), an inverter circuit whose aim is to provide ac power for the sensitive load through a switch.

2.4.2 SOLID STATE SYSTEM

This emergency lighting system has a general configuration like that of the standby power source. The exception is that the sensitive load operates continually from the output of the static inverter. A commercial power line, known as bypass is provided around the power source through a switch. This scheme is known as an online emergency lighting system.

2.4.3 ROTARY POWER SOURCE

This consists of a battery driven dc motor that is mechanically connected to an ac generator. The battery is kept in a charged mode by a battery charger, like the standby mode.

This project is based on the standby power source. This is the most convenient and has economical source of power. It has more advantages and uses a simplified circuit.

The fluorescent lamp was chosen because:

- it provides adequate illumination.
- it avoids glare and hard shadows.

-it provides sufficient uniformly distributed light over the working plane.

2.5 PRINCIPLE OF OPERATION

The automatic photo-sensitive emergency lamp with security alert system was designed following the block diagram of 2.1. a brief description of the block, that make up the design will be given thus;

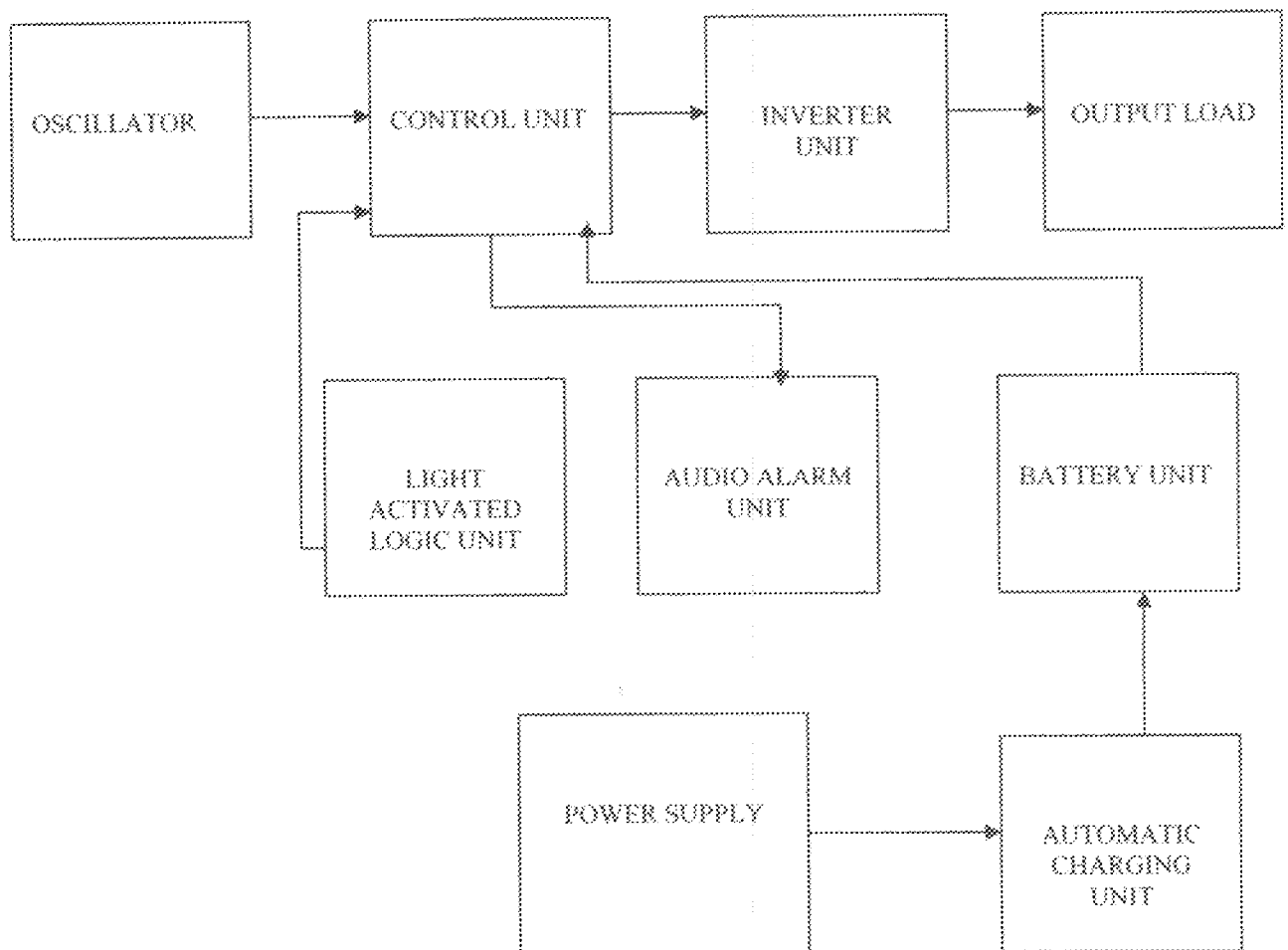

FIG 2.1 BLOCK DIADGRAM OF THE AUTOMATIC PHOTO-SENSITIVE EMERGENCY LAMP WITH SECURITY ALERT SYSTEM

2.5.1 POWER SUPPLY UNIT

The power supply unit is the supply from the mains. The voltage that comes from main source is a single phase 220/240 volts, with a frequency of 50Hertz (Hz), which needs to be stepped down before further usage. The main supply unit also consists of a 220/240v step-down transformer which serves two purposes: it isolates the circuit's d.c power lines from the main supply, and also changes the level of a.c main voltage (220/240v) to the lower voltage required (9v d.c).

2.5.2 AUTOMATIC CHARGING UNIT

Four IN4001 (diodes) are connected in a bridge to each other on the positive and negative terminals of the step down transformer and are used as a full wave rectifier to rectify the oncoming current into a unidirectional current. A capacitor is connected to the output of the rectifier to remove ripples from the power supply. The comparator helps in gauging the voltage level of the 6v lead acid battery. When the battery is fully charged, the charging is switched off through a PNP transistor (2SA400) which is supplying the charging current. A blocking diode is used to allow current flowing from the charger into the battery and not from the battery into the charger.

2.5.3 BATTERY UNIT

The battery unit in the design is a lead acid cell, a secondary cell which possesses the characteristic of irreversibility and storage of electrical energy. The voltage and current ratings of the battery are not constant, due to the effect of charging and discharging processes that occur in the battery. At maximum, the charging current is rated at 1.30A, while the voltage regulation consists of two stages namely: cycle voltage (7.35v-

7.50v) and standby voltage (6.75v-6.85v). It also has two terminals. (Positive and Negative)

2.5.4 LIGHT ACTIVATED LOGIC UNIT

The sensing device used is the light activated device called photodiode (TIL100). The light sensor is amplified using a NPN transistor (2SC945) which provides low voltage to SET terminal of the SR flip flop when the light sensor is exposed to light and a relatively high voltage to the SET terminal of the SR flip flop when the light senses darkness.

The photodiode consist of a normal P-N junction with a transparent window through which light can enter. A photodiode is usually operated in reverse bias and leakage current increases in proportion to the amount of light falling on the junction. This effect is due to the semiconductor that produces holes and electrons. The photodiode was used as the light sensor due to it's' ability to resist daylight interference better than the other light activated devices. In darkness the photodiode has a high resistance hence a low forward current.

2.5.5 AUDIO ALARM UNIT

The circuit is designed to trigger on an audio alarm whenever light is sensed by the light sensor. The audio alarm unit is connected to the SR flip flop (4013B) through the input of an AND gate the other input of the AND gate is connected to the oscillator (4060B). The oscillator provides frequency to the point. Whenever light is sensed and the switch is on, the output of the SR flip flop is HIGH and the AND gate is enabled. Moreover, the audio frequency from the oscillator is allowed to flow to an NPN transistor (2SD400). The transistor amplifies the audio signal to the 1watt 8ohm speaker. The audio alarm is heard at the speaker whenever the switch is on.

2.5.6 CONTROL UNIT

The inverter needs a good control. The control unit is designed to allow the blockage of the necessary pulse to the gates of the MOSFETS (IRF 244) to cause the alternation of the voltage at the primary end of the transformer. The AND-or gate circuit allow 2-1 control of the pulse.

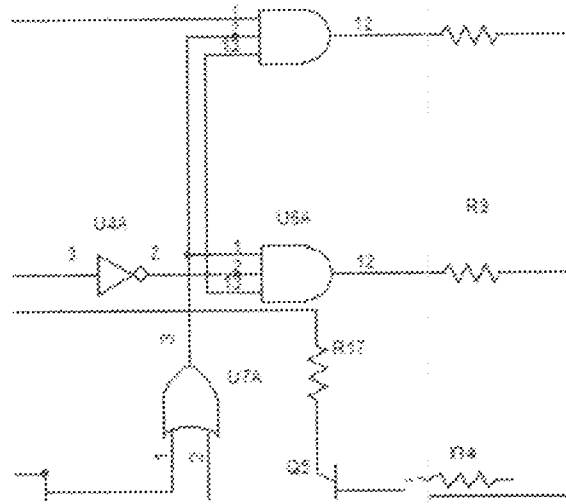

FIGURE 2.2 THE CONTROL UNIT

One AND gate is enabled whenever one of its input is HIGH. The pulse from the oscillator is simply passed out to the output (2-input AND gate). For the OR gate whenever one of the input is HIGH, the output is also HIGH. When the inputs of the OR gate are LOW, the output is also LOW. This makes one of the inputs of both AND gate to be LOW. This results in disabling of the two AND gate. Also no change of flux at the transformer will occur, and there will be no output voltage to power the fluorescent.

2.5.7. THE INVERTER UNIT

In the event of an outage, the battery supply sufficient power to the inverter to maintain its output for a specified time. The inverter converts direct current to alternating

current. The N-channel MOSFETS (IRF 244) in the unit helps in generating a better substantial amount of electric current through alternating conduction and a step up transformer. When a low pulse is applied to the gate, the drain and source are disconnected, making the drain to be cut off.

When a high pulse is applied to the gate of the MOSFET, current flows from the positive terminal of the transformer to the drain because the drain is at low voltage. Current flows from the positive terminal of the transformer to the drain because the drain is at low voltage. Current flows in the primary of the transformer alternating, because of the application of a NOT gate to the gate of one the MOSFETS. When one is switched on the other is off and this alternating process changes the d.c to a.c in the primary of the transformer.

2.5.8 THE LIGHTING UNIT

This is the output of the design. The fluorescent used is the 5W energy saver tube. The output of the step up transformer gives the voltage needed to light up the fluorescent, instantaneously when the circuit switch is closed.

CHAPTER THREE

This chapter reveals the detailed explanation of the general principle, theory and design of the automatic photo-sensitive emergency lamp with security alert system. The design is divided into different units: power supply unit, automatic charging unit, battery unit, light activated logic unit, audio alarm unit, oscillator, control unit, inverter unit, lighting unit.

3.1 POWER SUPPLY UNIT

The power supply unit can be divided into four stages, namely: transformation stage, rectification stage, filtering stage and regulation stage. The block diagram of a typical power supply unit using bridge rectifier is shown below.

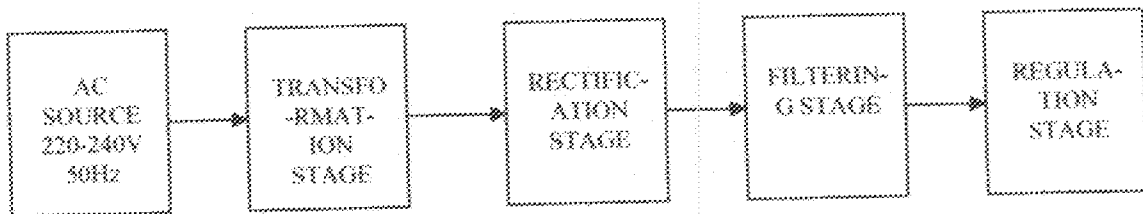

Fig 3.0 Diagram of a power supply using bridge rectifier

3.1.1 TRANSFORMATION STAGE

An Ideal transformer is a loss less device with an input winding and an output winding. The relationships between the input voltage and the output voltage and between the input current and the output current are given by two simple equations. Fig 3.1 shows an ideal transformer which has N_p turns of wire on its primary side and N_s turns on its secondary side.

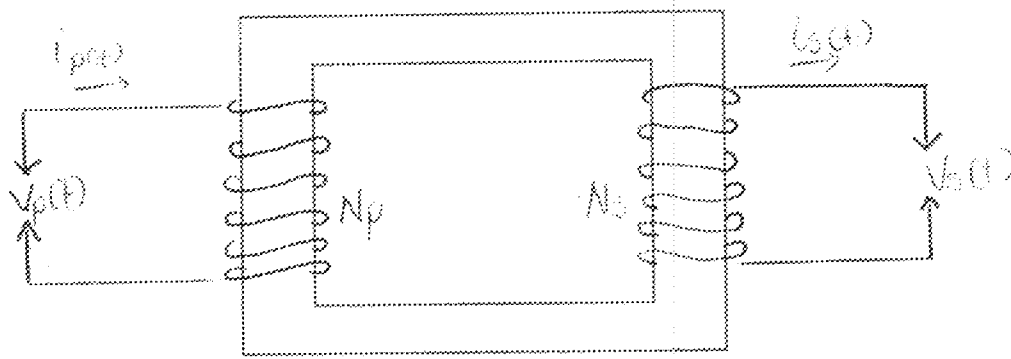

Fig. 3.1 An Ideal Transformer

$$V_p(t) / V_s(t) = N_p / N_s = a \quad \text{-----} \quad 3.1$$

Where a is defined to be turns of the transformer:

$$a = N_p / N_s \quad \text{-----} \quad 3.2$$

$$N_s(t) / N_p(t) = i_p(t) / i_s(t) \quad \text{-----} \quad 3.3$$

Therefore

$$i_p(t) / i_s(t) = N_s(t) / N_p(t) = 1/a \quad \text{-----} \quad 3.3(a)$$

In terms of the phase quantities, these equations are

$$V_p / V_s = a \quad \text{-----} \quad 3.4$$

Also

$$i_s / i_p = a$$

Therefore

$$\begin{aligned} V_p / V_s &= i_s / i_p \\ V_p i_p &= V_s i_s \quad \text{-----} \quad 3.5 \end{aligned}$$

Where

$V_p i_p$ is the input power (P_{in}) of the transformer and

$V_s i_s$ is the output power (P_{out})

Since the voltage is stepped down to 9V (+9V and -9V)

$$V_p = 240\text{Volts}$$

$$V_s = 9\text{Volts}$$

$$i_s = 500\text{mA}$$

The turn ratio of the transformer is

$$V_p / V_s = a$$

$$a = 240 / 18 = 13.33$$

Also

$$i_s / i_p = a$$

$$i_p = i_s / a = 500\text{mA} / 13.3$$

$$i_p = 37.5\text{mA}$$

Input power is thus found to be

$$P_m = V_p i_p = 240\text{V} * 37.5\text{mA}$$

$$P_m = 9\text{Watts}$$

The output power is

$$P_{out} = V_s i_s = 18\text{V} * 500\text{mA} = 9\text{Watts}$$

Also

$$V_s = N_s = i_p$$

$$V_p = N_p = i_s$$

$$9/240 = N_s / N_p = 1/27$$

Hence the ratio of the secondary voltage to the primary voltage is 1:27

The ratio of the primary current to the secondary current is 1:27

1. the size of the capacitor
2. the value of the load
3. the time between the pulsations

These three factors are related by the formula

$$T = R * C$$

To get a good filtering, large capacitor is used because it will take longer time for the capacitor to discharge. The capacitor used here is 2200 μ /25Volts. When the diode or rectifier is conducting, the capacitor charges rapidly, storing electrons at peak voltage. Similarly, it discharges the stored electrons to the charging unit when the rectifier is not conducting. Also the charging and discharging effect of the electrolytic capacitor (2200 μ F), helps to smoothen out the pulses from the rectifier's output.

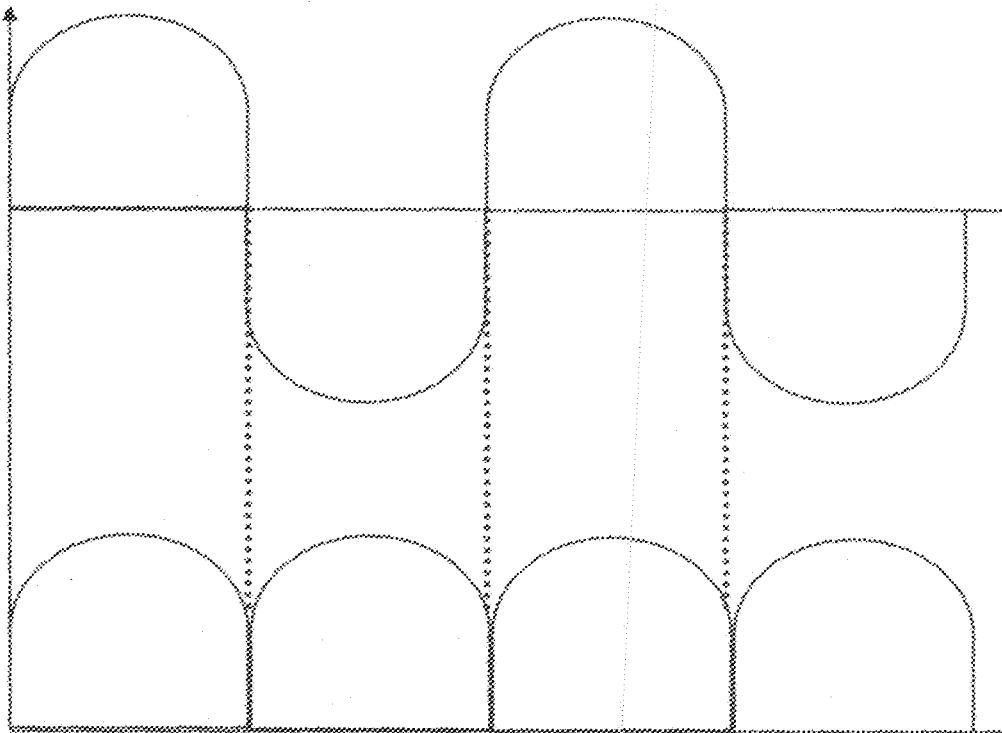

Fig. 3.3 The full wave rectifier out waveform

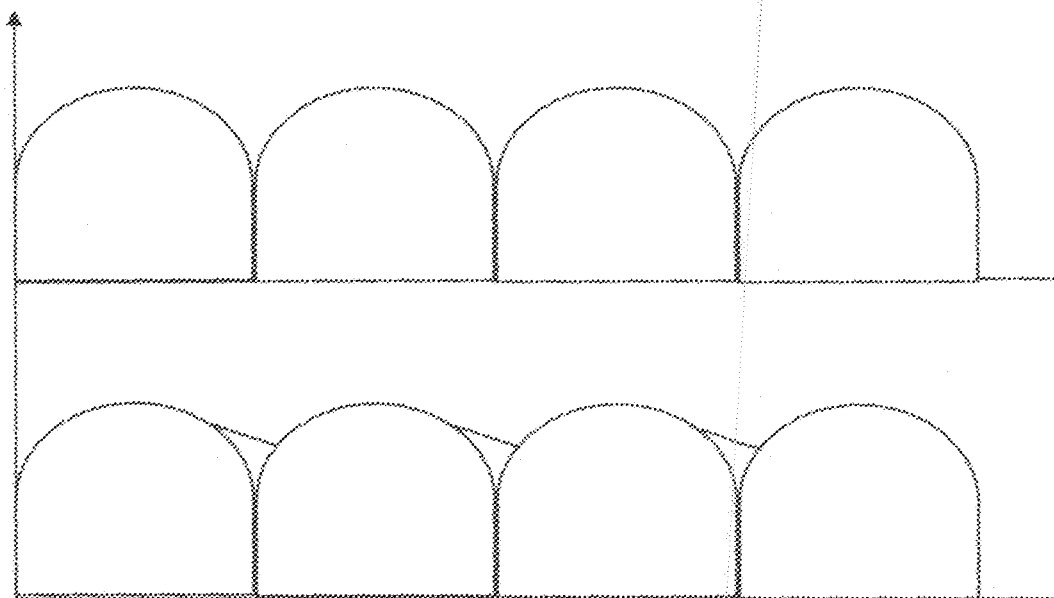

Fig 3.3a The filtering action of the capacitor

Regulation Stage

The regulation of a power supply is its ability to hold the output steady under conditions of changing load. Typical applications are DC parameters. Load regulation; Ripple rejection fixed output regulation, constant current regulator and a lot more. The voltage regulator used is the 7805 which regulates the voltage to 5V, needed by components in the circuit.

3.2 THE COMPARATOR

A comparator is a circuit which compares two signal or voltage levels. The comparator (LM 399) inverting input (-) is made the reference by connecting to a 220 Ω resistor a zener diode (0.7V). The non-inverting input (+) is connected to a 2.2k Ω potential divider circuit. The potential divider is directly connected to the positive terminal of the 6V battery. So that the variation in voltage supply of the battery can be

monitored by the comparator. The $2.2k\Omega$ potential divider is used to adjust a voltage slightly below $0.7V$ to the corresponding non inverting input (+). So that a relatively zero voltage is supplied to the base of the PNP transistor (2SA400) through the base – bias $10k\Omega$ resistor. The low level at the base switches on the transistor. This cause the current that is needed to charge the battery to flow from the collector to the positive terminal of the battery. When the battery is fully charged, the non inverting input of the comparator becomes relatively higher than the reference voltage ($0.7V$) at the inverting input. This results in the output changing from LOW to HIGH. The PNP transistor is cut – off and the charging stops.

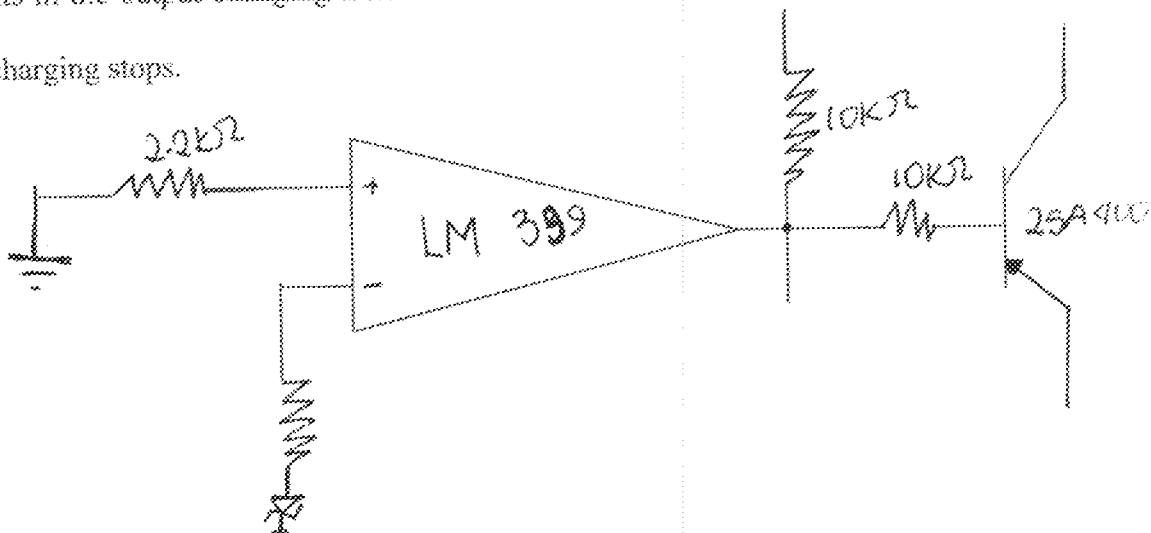

Fig. 3.4 The Comparator and Surrounding Components

3.3 THE OSCILLATOR

The 4060B is a 14 stage binary ripple counter with an on – chip oscillator configuration allows design of either RC or crystal oscillator circuit. Also included on the chip is a reset function which places all outputs into the zero state and disables the oscillator. A negative transition on clock will advance the counter to the next state. Schmitt trigger action on the input line permits very slow input rise and fall times. Applications include time delay circuits, counter controls and frequency dividing circuits.

- Fully static operation

- Diode protection on all inputs
- Supply voltage range = 3.0V to 18V
- Capable of driving two low power TTL loads or one low power schottky TTL load over the rated temperature range
- Buffered outputs available from stage 4 through 10 and 12 through 14
- Common reset time
- Pin – for Pin replacement for CD4060B

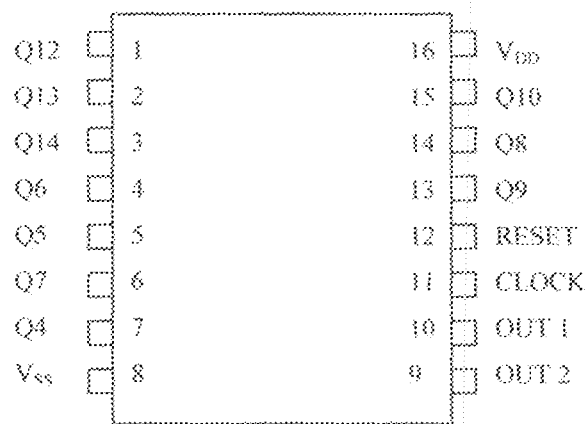

Fig. 3.5 Pin assignment of 4060

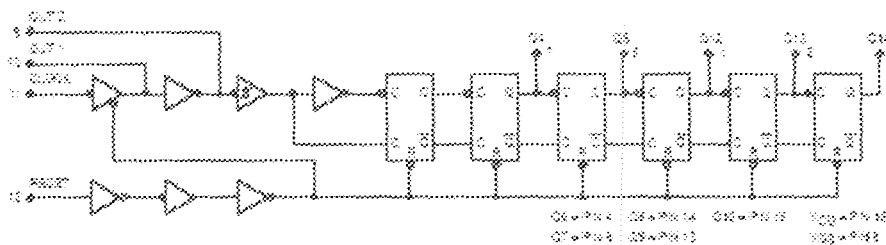

Fig. 3.6 The logic diagram

The IC features both RC and crystal configuration. The RC oscillation configuration is used for the project. They are connected at pins 9,10 and 11 as shown below.

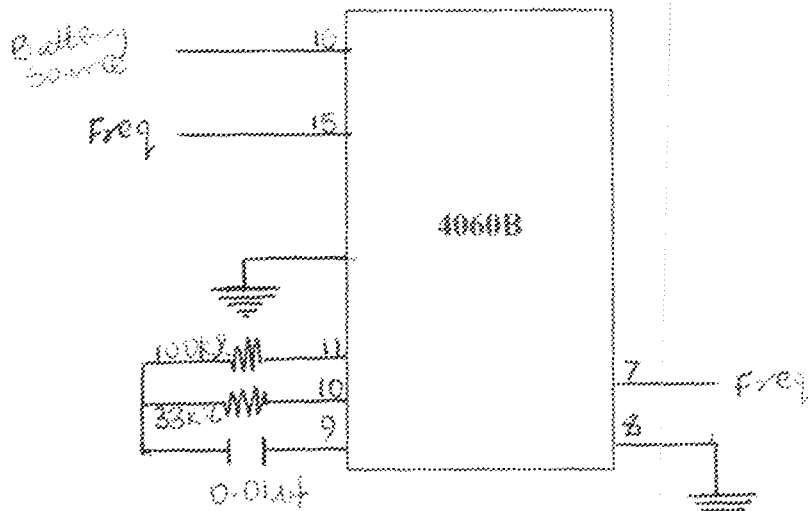

Fig. 3.7 Diagram showing the connecting of pins

The frequency of the oscillator is given by

$$f = \frac{1}{2.3R_x C_x} \dots \dots \dots 3.7$$

as per manufacturing design. Other design considerations are

1. $R1 = 2R_x$ to $10R_x$
2. RC oscillator application not recommended at supply voltages below 7.0V
for $R_x < 50k\Omega$

$$f = \frac{1}{2.3 \times 33 \text{ k}\Omega \times 0.01 \mu\text{F}}$$

$$f = 1.3 \text{ kHz}$$

the frequency at pin 15 will be

$$f_{15} = \frac{f}{2^{10}}$$

$$f_{15} = \frac{1.3 \text{ kHz}}{2^{10}} = 1.27 \text{ Hz}$$

The frequency at pin 7 will be

$$f_{67} = \frac{1.3 \text{ kHz}}{2^3} = 81.25 \text{ Hz}$$

3.4 THE FLIP - FLOP

The 4013B consist of two identical, independent data type flip – flops. Each flip-flop has independent data, set, reset and clock inputs and Q and \bar{Q} outputs. These devices can be used for shift register application and by connecting Q output to the data input, for counter and toggle applications. The logic level present at the D input is transferred to the Q output during the positive – going transition of the clock pulse. Setting or resetting is independent of the clock and is accomplished by a high level on the set or reset line respectively. Applications are for control circuits, registers and counters. The truth table of the SR flip flop is given below.

TABLE 3.1 FLIP FLOP TRUTH TABLE

| S | R | Q | \bar{Q} |
|---|---|---|-----------|
| 0 | 0 | 0 | 1 |
| 0 | 1 | 0 | 1 |
| 1 | 0 | 1 | 0 |
| 1 | 1 | 1 | 1 |

3.5 THE LIGHT SENSOR

A photodiode is a semiconductor diode which depends for its operation on the minor photoelectric effect. The incident light flux controls the reverse current of a photodiode. When there is no light flux incident on the device, the usual reverse leakage current, called the dark current, is flowing through the device.

The light sensor amplifier, using a single NPN transistor (2SC945) is designed to provide a low voltage to the SET terminal of the flip – flop when the light sensor is exposed to light and a high voltage to the SET terminal of the SR flip – flop when the light sensor is in darkness.

A high voltage at the SET input of the SR flip – flop will turn Q HIGH. This will make one of the inputs of the OR gate HIGH and then allow the passage of the necessary pulse.

The reset of the flip – flop makes Q LOW

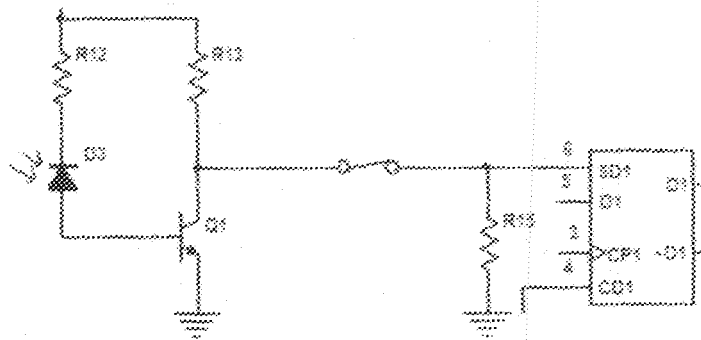

Figure 3.8 The photodiode

3.6 THE CONTROL UNIT

The AND – OR gate circuit allows a 2 – 1 control of the pulse.

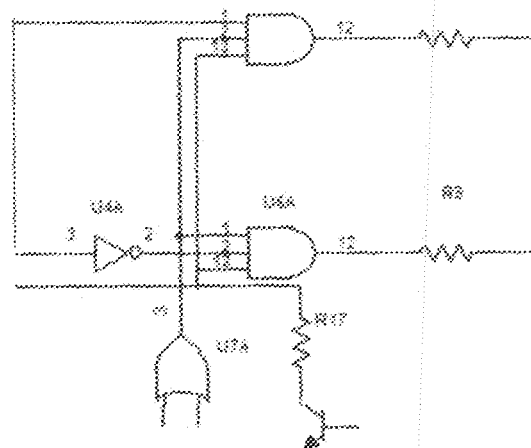

Fig. 3.9 The control unit

When the base of the NPN transistor is low, the collector will be high thereby making one of each inputs of the AND gate high. Also when Q is high, the OR gate will also be high. The pulse from the oscillator makes one AND gate high and the other low (because of the NOT gate at its input). This will cause the output of the AND gates to alternate (i.e. one will be high and the other low).

TABLE 3.1 TRUTH TABLE OF THE AND GATE

| A | B | Y |
|---|---|---|
| 0 | 0 | 0 |
| 0 | 1 | 0 |
| 1 | 0 | 0 |
| 1 | 1 | 1 |

TABLE 3.2 TRUTH OF THE OR GATE

| A | B | Y |
|---|---|---|
| 0 | 0 | 0 |
| 0 | 1 | 1 |
| 1 | 0 | 1 |
| 1 | 1 | 1 |

3.7 THE AUDIO ALARM

The circuit is designed to trigger on an audio alarm whenever light is sensed by the light sensor at the amplifier stage.

The audio alarm is connected to the SR flip flop through an AND gate the other input is connected to pin 7 of the oscillator. Whenever light is sensed and the switch is on, the Q

output of the flip – flop goes HIGH. The AND gate is enabled and the frequency from the oscillator is allowed to flow to the NPN transistor. The transistor amplifies the audio signal to the 1 watt 8Ω speaker and the alarm is heard.

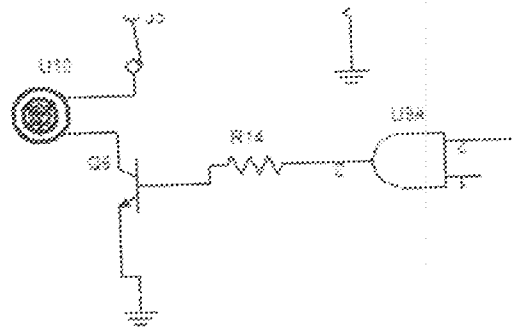

Figure 3.10 The audio alarm

3.9 THE INVERTER

In the event of an outage, the battery supply sufficient power to the inverter to maintain its output for a specified time, usually from minutes to hours depending on the duration taken by the battery to discharge to a predetermined minimum voltage before it turns off. The inverter in this design is meant to carry out the purpose of conversion of direct current to alternating current. This is achieved by the switching ON and OFF of two MOSFET one after the other from the pulses coming from the control unit.

The N channel MOSFETs (IRF 244) has its source connected to ground. When a low voltage is applied to the gate terminal, the MOSFET will not conduct. When a high voltage is applied to the gate terminal, current will flow from the drain to the source. The drain is more positive than the source. From the diagram below, a high voltage applied to the gate of one of the MOSFET will cause current to flow from the positive terminal of the transformer to the drain because the drain is negative. Current flows in the primary of the transformer alternately because of the application of a NOT gate applied to one of the gate of the MOSFET. When one is turned ON the other if turned OFF and the alternating

process changes the D.C. to A.C in the primary of the transformer. The secondary steps up the primary voltage as a result of change in flux linkage and the number of turns ratio. The corresponding A.C. voltage at the secondary powers the 5W energy saver tube.

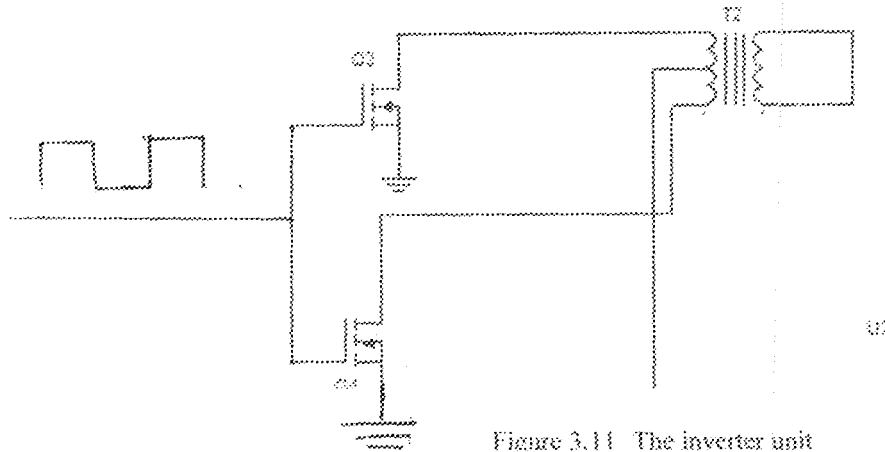

Figure 3.11 The inverter unit

Now

$$P_s = P_p$$

$$I_s V_s = I_p V_p$$

$$V_p / V_s = I_s / I_p = N_p / N_s$$

$$V_p = 6 \text{Volts from battery}$$

$$V_s = 240 \text{V}$$

$$6 / 240 = 1 / 40$$

The ratio of voltage in primary to the secondary is 1:40. Also the ratio of the current in the secondary to the primary is 1:40. Therefore, the voltage in the secondary is stepped up and the current is reduced. The complete circuit diagram of the automatic photo-sensitive emergency lamp with security alert system is as shown in figure 3.12.

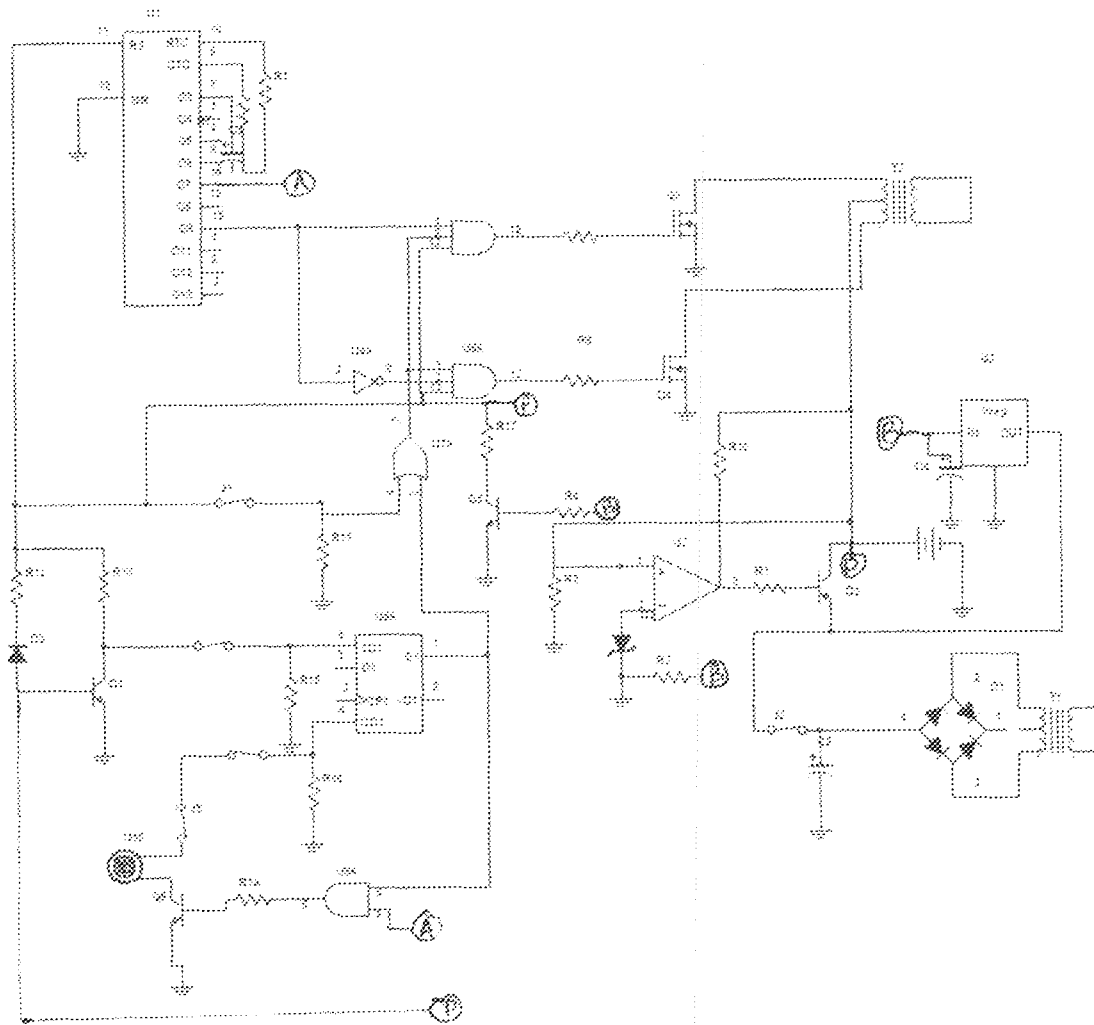

Figure 3.12 The circuit diagram

CHAPTER FOUR

4.0 CONSTRUCTION TESTING AND RESULT

In line with the objectives of this project work, after an in depth analysis of how the circuit is supposed to function, the next step is the physical construction of the circuit on a prototype electronic board and powering the prototype to see if it will operate as expected.

Before construction, several things were taken into consideration of which are the theory and design of each stage.

The construction tools and equipment are listed below:

1. Bread board
2. soldering iron
3. Soldering Lead
4. IC Socket
5. Vero board
6. Snipper
7. Meter

BREAD BOARD

This is a perforated board on which electronic components may be mounted and quickly wired for the preliminary test of a circuit. It is so called because the first such foundation units of this sort actually were wooden bread boards

SOLDERING IRON -

An electric tool having a heated tip for melting soldering lead.

- SOLDERING LEAD -** Lead is a metallic element with atomic number and atomic weight 207-21. It is a conductor that is used for making connections on circuit boards and for holding components in place.
- IC SOCKET -** A fixture into a plug transistor, IC or other components are inserted for easy installation on or removal from a circuit.
- VERO BOARD -** This is a perforated board on which electronic components may be permanently mounted and soldered as prototype.
- SNIPPER -** This is like a pair of scissors that is used for removing excess solder after soldering.

Before the prototype construction, there was the need to set up the circuit on a breadboard for preliminary testing and to make sure that the circuit is functioning properly. If the prototype was built without this preliminary stage there is the probability that the circuit may not work properly after connection on the Vero board, since this is a permanent stage, there might be problems involved in removing the soldered components which cause damage to the terminals and components.

A bread board is a rectangular board with dimension 17.2 X 6.5cm which has a base laid with strips of conductors and perforated holes leading to the external world through which contacts can be made with the conductors. The inlaid conductors are continuous vertically for the inner perforations and horizontally for the outer perforations.

Connections were made on the bread board with care not to short circuit any component. These connections were made by plugging component terminals into the perforated holes and using connection wires. A 6V adapter was used to power the circuit and it was tested at night. When the light was switched off, the lighting load came on and

the alarm signal started ringing. The circuit was left on in darkness, and about the estimated time the lighting load went off.

The next thing that was considered was the size of the Vero board to be used. The number of components to be used and the amount of space they would occupy. Finally each component was cross - checked and examined to make sure they functioned properly. The terminal of the transistors, capacitors and diodes were identified so as to make sure they are connected properly. Secondly, the positions to be occupied by each component were carefully marked out with a pencil. The positive and negative rails to be used as supply on the Vero board were also marked out.

Components were inserted on the Vero board and connections were made using soldering lead and connecting wires. The IC's were mounted on IC sockets in case the need arises to change the IC due to damage.

During soldering the components were properly placed so that no bridging was created by the deposited solder.

Care was taken not to allow heat to destroy some of the circuit components (by heat from the hot soldering iron). The Vero board was properly cleaned before and after the soldering process. After soldering, the deposited lead was trimmed with a snipper for a neat job. The prototype was tested and it worked properly.

4.1 TESTING AND RESULT

The rating of the battery was made on cycle voltage 7.20 - 7.50V and standby voltage 6.75 - 6.90V and its maximum charging current was 1.35A. Also the fluorescent lamp on the other hand had a voltage of 220V and a current range of 0.01 - 0.1m/A at its output.

The result obtained after the test operation was that, the battery could charge up to maximum for about 12 – 14hours on an approximate value of voltage 6.85V – 7.21V, and a current of 875mA. Hence the luminous intensity of the fluorescent lamp explains the charging and discharging the battery to its maximum voltage, it begins to discharge immediately when there is failure from the main power supply and the brightness of the fluorescent lamp shows that the battery is fully charged. Undermining the charging period, a state would reach when the luminous intensity of the lighting source reduces (i.e the light dims) this implies that the battery has discharged to its minimum voltage.

4.2 PROBLEMS ENCOUNTERED

1. The fluorescent tube did not come on when the circuit was powered. It was discovered later that the tube was dead and was changed.
2. The problem of getting a suitable step-up transformer for the project.
3. The problem of tuning the audio alarm.
4. Short-circuit during the course of soldering of components
5. The problem of adjusting the sensitivity of the light sensor.

A wooden case was constructed on which the circuit was mounted. Figure 4.1 shows the sketch of the constructed photo-sensitive lamp with security alert system.

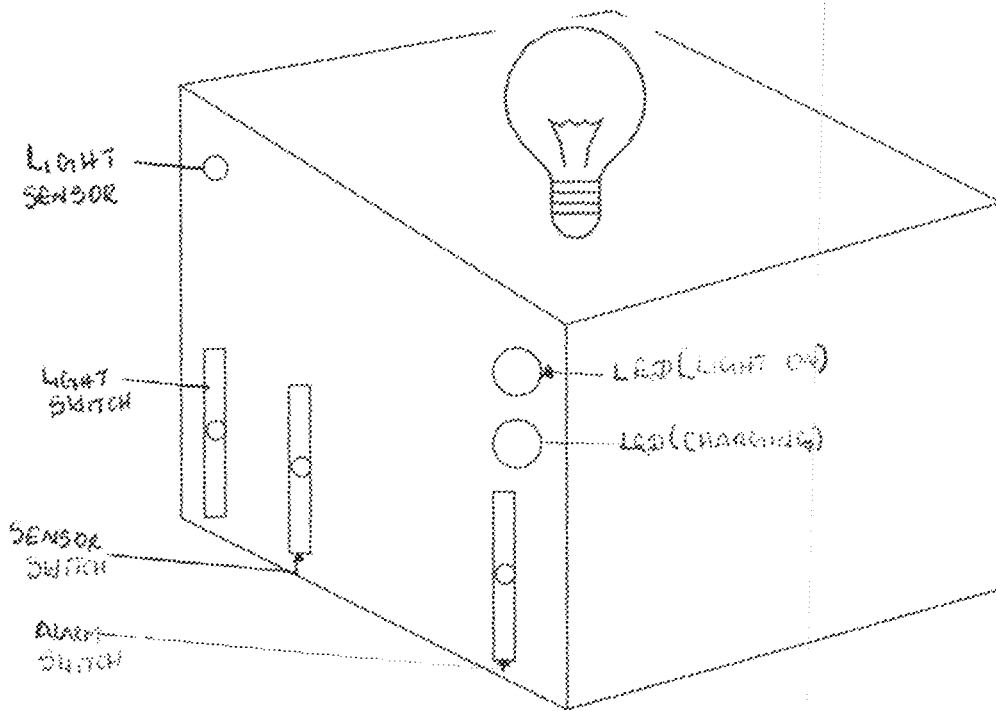

FIG 4.1 HOUSING UNIT

TABLE 4.1 BILL OF QUANTITIES

| S/N | COMPONENTS | QTY | UNIT(N) | AMT(N) |
|-----|--------------------------|-----|---------|--------|
| 1 | IC 4060B(OSCILLATOR) | 1 | 120 | 120 |
| 2 | IC 4013B(FLIP FLOP) | 1 | 120 | 120 |
| 3 | IC 4081B | 1 | 120 | 120 |
| 4 | IRF244(MOSFETS) | 2 | 150 | 300 |
| 5 | IC Lm339 | 1 | 60 | 60 |
| 6 | Watt 8Ω speaker | 1 | 80 | 80 |
| 7 | 6V battery(rechargeable) | 1 | 600 | 600 |

| | | | | |
|-------|---------------------------------|---|-----|------|
| 8 | 6V-0-6V transformer | 1 | 150 | 150 |
| 9 | 9V TRANSFORMER | 1 | 150 | 150 |
| 10 | 1N 4001 | 4 | 5 | 20 |
| 11 | 1000 μ f 2.5V capacitor | 1 | 50 | 50 |
| 12 | 2SC945 transistor | 3 | 10 | 30 |
| 13 | 100k Ω variable resistor | 2 | 2 | 4 |
| 14 | 2SA733 PNP Transistor | 1 | 50 | 50 |
| 15 | Vero board | 1 | 120 | 120 |
| 16 | Toggle Switch | 3 | 50 | 150 |
| 17 | Soft touch button | 1 | 20 | 20 |
| 18 | LED | 2 | 5 | 10 |
| 19 | 5W 220V LAMP | 1 | 100 | 100 |
| 20 | Lamp holder | 1 | 50 | 50 |
| TOTAL | | | | 2304 |

CHAPTER FIVE

CONCLUSION AND RECOMMENDATION

5.1 CONCLUSION

At the end of the projects, the practical work was tested to find out if the goals/objective of the project were met. It was found out that the constructed project work functioned properly.

Also, in the course of this design, it was understood that power supply can be stored for a certain amount of time and later distributed by storage device to its load through means of supply. It was shown too, that electronic components are not meant to be connected directly to any supply unit, due to the fact they operate with a small amount of current. The lighting system can be on for about an hour when the battery is in good condition.

5.2 RECOMMENDATION

The project work forms a vital part of the university education and is of many benefits to the students for it is more effective and has more impact. I recommend that:

1. Components should be provided to students to enable they embark on the construction of many projects thereby strengthening their hands.
2. The switch in the circuit can be made digital by the use of a soft-touch switch and corresponding integrated circuit.
3. A timer can be incorporated into the circuit. And it can work with the audio alarm.
4. A battery level indicator can be incorporated into the circuit to show the power level of the battery.

REFERENCE

1. Internet: <http://www.light.com>.
2. Internet: <http://www.krisbur.com>.
3. Grober Family, Encyclopedia, 1987, Danbury, volume 11.
4. Uwaifo. s.o, Electric power distribution, planning and development, Malthouse, lagos. 1994.
5. Internet: <http://www.fairchildsemi.com>, revised January 1999, fairchild semiconductor TM DS00S90 prf.
6. Internet: <http://www.design-NET.com>
7. Internet: <http://www.discovercircuits.com>
8. B.L. Theraja and A.k Theraja, a textbook of Electrical Technology, s. Chand and company ltd (2002) ISBN 81-219-1473-6, pages 1676 and 1677.
9. Paul Horowitz and Winfield Hill, The art of electronics, 2nd edition. Cambridge university press. Pages 61-65, 484, 507-514.
10. Texas instrument data sheet from Harris semi conductor, SCH 8072 pages 3-255-3-259.
11. Albert. P.M, Electronic principle, 3rd edition MC Graw-hill, Newyork, 1983.
12. Lionel H, Electronics and Electrical Engineering, 2nd edition, Maximillian press 1998, London.
13. Fredrick j. Hill and Gerald r. Peterson, introduction to switching theory and logical design, 3rd edition, Pages 64 and 65.
14. Elin Idekpe Daniel , Design, construction and testing of an emergency lighting system. Department of electrical/computer engineering, FUT Minna.(93/3573EE).