

DESIGN AND CONSTRUCTION OF
TELEPHONE-OPERATED NIGHT LIGHT

BY

OKOLI NNAMDI

98/7150EE

DEPARTMENT OF ELECTRICAL AND COMPUTER ENGINEERING
SCHOOL OF ENGINEERING AND ENGINEERING TECHNOLOGY
FEDERAL UNIVERSITY OF TECHNOLOGY, MINNA.

NOVEMBER, 2004.

DESIGN AND CONSTRUCTION OF
TELEPHONE-OPERATED NIGHT LIGHT

BY

OKOLI NNAMDI

98/7150EE

A PROJECT REPORT SUBMITTED IN PARTIAL FULFILLMENT OF THE AWARD
OF BACHELOR OF ENGINEERING (B.ENG) DEGREE IN THE
DEPARTMENT OF ELECTRICAL AND COMPUTER ENGINEERING,
FEDERAL UNIVERSITY OF TECHNOLOGY, MINNA.

NOVEMBER, 2004.

CERTIFICATION

This is to certify that this project titled "Design and Construction of Telephone-Operated Night Light" was carried out by Okoli Nnamdi under the supervision of Engr. P.O. Attah and submitted to the Electrical and Computer Engineering Department, Federal University of Technology, Minna, in partial fulfillment of the requirement of the award of Bachelor of Engineering (B.Eng) degree in Electrical and Computer Engineering.



Engr. P.O. Attah
(Project Supervisor)



Date

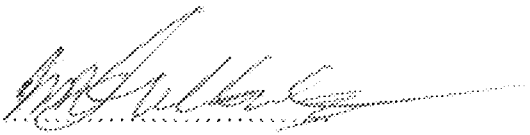

Engr. M.D. Abdullahi
(Head of Department)

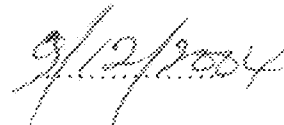

Date

.....

External Examiner

.....

Date

DECLARATION

I, OKOLI NNAMDI, with matriculation number 98/7150EE. Hereby declare that this project is my original work and it has never to my best of knowledge being presented in any form elsewhere for award of any degree.

DEDICATION

This project work is dedicated to my late sister Patience Ndihamaka Okoli - May your gentle soul rest in peace.

ACKNOWLEDGEMENT

All thanks to God Almighty, the Author and finisher of my faith for His goodness and mercy on first my family and me. May His name be praised forever-Amen.

My special thanks go to my ever caring and loving parents Mr. and Mrs. Reuben Okoli and the entire family of Okolis for their love, care and support rendered for my success in life.

Staying focused and on track is a great work and needs great attention and skill to keep up and so my profound gratitude goes my able diligent and kind hearted supervisor Engr. P.O. Attah for his tireless and unrelenting monitoring of this project work, always keeping me focused and on track in terms of knowledge and advice especially through the course of this work. You put me through this and I deeply appreciate.

My special gratitude goes to my Head of Department Engr. M.D. Abdullahi, for your fatherly advice, Mr. and Mrs. Godwin Ebisi, Mr. Mike Ononenyi, Mr. and Mrs.

Humphrey Okoli for the role they played.

Finally, I would end by saying thanks to my folks who kept me company and also to all who know they deserve this thanks. You guys made all the hustling and busting round school worth the while.

ABSTRACT

For the fact that a direct voltage of 48-60v exists at terminals a and b in most telephone network, when a call signal comes in at frequency of 25-27Hz, a 50-60v alternating current is superimposed on the direct voltage.

The present circuit starts a timer when it detects the call signal. Relay Re_1 is energized by the timer and this switches ON lamp La_1 . After the last ring, the timer remains ON for a short time and returns to its quiescent state, whereupon the lamp goes out. When the receiver is taken from the hook, however, the timer is triggered permanent so that the lamp remains ON during the telephone conversation and for sometime afterwards it goes out.

The lamp can also be controlled by pressing switch S_1 ON and OFF manually.

TABLE OF CONTENT

ITEM	PAGE
TITLE PAGE	ii
CERTIFICATION	iii
DECLARATION	iv
DEDICATION	v
ACKNOWLEDGEMENT	vi
ABSTRACT	vii
CONTENT	viii
CHAPTER ONE	
1.0 GENERAL INTRODUCTION	1
1.1 INTRODUCTION	1
1.2 LITERATURE REVIEW	2
1.3 PROJECTION OBJECTIVES AND JUSTIFICATION	5
CHAPTER TWO	
2.0 THEORY OF OPERATION	7
2.1 OPTOISOLATOR	7
2.2 THE DETECTOR CIRCUIT	8
2.3 THE PROCESSOR CIRCUIT	10
2.4 THE AUTO SWITCH CIRCUIT	12

2.5 THE POWER UNIT	13
2.6 PRINCIPLE OF OPERATION	14
2.7 CONSTRUCTION	18
2.8 CALCULATIONS	18
CHAPTER THREE	
3.0 CONSTRUCTION AND TESTING OF THE PROJECT	20
3.1 POWER UNIT	20
3.2 CONSTRUCTION OF OTHER MAIN UNITS	22
3.3 TESTING	23
3.4 TESTING FOR WORKABILITY	23
3.5 CASING	24
CHAPTER FOUR	
4.0 CONCLUSION AND RECOMMENDATIONS	26
4.1 CONCLUSION	26
4.2 RECOMMENDATIONS	26
REFERENCES	27
APPENDIX	29

CHAPTER ONE

1.0 GENERAL INTRODUCTION

1.1 INTRODUCTION

Communication is the sending, processing and receiving of information, ideas, and messages. The information to be sent takes the form of written message, voice message or an electrical signal etc

A communication system can be defined as a system of sending, processing, and receiving of signals. The means of communication can be of a radio link, optical fibre, satellite and telephone network. Telecommunication is therefore the transfer of information from one point to a distant point.

It is the key part of today's civilization. The prefix 'Tele' is from the Greek word meaning 'Far'. One can now imagine a world without ready access to reliable, economical and efficient means of communication. Therefore, in a world of constant competition, communication is very important to the biological survival of all living creatures. Even animals do communicate by body movement or by making sound to indicate danger.

It is now taken for granted that by pressing a few buttons, people could link to families, friends or business associates across the world. Communication via telephone could be in the daytime or at night. Usually calls in the dead of the night have significant measure of seriousness attached to it. For example, a doctor could be sleeping in his room at night and his attention will be needed urgently in the hospital owing to emergency case.

Most people sleep with light turned off, therefore, this project which is on the design and construction of telephone-operated night light enables the switching of light on detecting a call signal, this light illuminates the room allowing one to see in the room whenever one has a call and remains ON while the conversation lasts i.e. when the receiver is taking from the hook, and for sometime afterwards it goes OFF. Whereupon one could not wake up to answer the call, after the last ring and for sometime afterwards, the light goes OFF.

Some other people sleep with light dimmed, in such a case, the telephone-operated light is illuminated well enough than the dimmed light to make one see in the room.

Furthermore, the lamp may be switched ON and OFF manually by the switch being depressed.

1.2 LITERATURE REVIEW

It has always been the desire of man to communicate from afar. So, it would be appropriate to say that telephone history began at the start of human history. In time past, people use different method to get message from a point to another. People had use such method as smoke, signal mirrors, jungle drums, carrier pigeons and semaphores to get a message.

The telephone, which is defined as an apparatus for reproducing sound, especially that of voice at a great distant, by means of electricity consisting of transmitting and receiving instruments connected by a line, or wire which conveys the electric current, was something new. Francis Bacon predicted the telephone in 1627, however, only a long speaking tube was described in his book titled the New Utopia. A real telephone could

not be invented until the electrical age began. The electrical principles needed to build a telephone were known in 1831 but it was not until 1854 that Boursell suggested transmitting speech electrically.

Not until 1876 did Alexander Graham Bell, a man who taught deaf people how to talk receive a patent for an electric phone. From many experiments, he learned that only a steady electric current could transmit the human voice. The next year, he made the first phone that could transmit the human voice accurately. His phone consisted of a transmitter, a receiver, and a single connecting wire. He demonstrated it at the one-hundredth anniversary of the United States in Philadelphia.

The telephone was an immediate hit over the next fifty years; nearly every household in the industrialized world had the new invention installed. The telephone then by Graham Bell was a crude thing made of a wooden stand, a funnel, a cup of acid and some copper wire. Thomas Watson fashioned this simple device, and was the forerunner of what the telephone and its function (s) have become today. The telephone invention witnessed progress as a result of the coming together of Bell and Watson. This merger brought progress on improving the telephone range and achieved the longest call of a distance of 2 miles (3.22km) on October 9, 1876.

Improved transmitter that relied on the diaphragm modifying an existing electrical current and outside power source was later incorporated by bell into the telephone. This was after the invention of Thomas Edison's carbon black transmitter in late 1870s. This made telephone very practicable. The human voice was used by Bell's first telephone transmitter to generate a weak electromagnetic field, which then went to a distant receiver. Bell later installed larger and better magnets into this telephone.

On July 19, 1881 Bell was granted a patent for the metallic circuit, the concept of two wires connecting each telephone. Until that time a single wire connected subscribers just like a telegraph. Then, conversation was over one wire since grounding each end provided a complete path for an electrical circuit. But homes, factories and the telegraph system were all grounding their electrical circuits using the same earth the telephone company employed. Consequently, a huge amount of static and noise were introduced by using a grounded circuit. A metallic circuit, on the other hand, used two wires to complete the electrical circuit avoiding the ground altogether. This provided a better sounding call.

First automatic dial system began operating in La Porte, Indiana in 1892 and the first automatic commercial exchange began operation also in 1892. The central office switch worked in concert with a similar switch at the subscriber's home, operated by push buttons patented in 1891 by Alma B. Strowger. This step-by-step system replaced the switchboard operator for placing local calls. Strowger's switch required different kinds of telephones and eventually models with dials. The rotating finger wheel needed for a dial was later invented by A.E. Keith (internal link), J. Erickson and C.J. Erickson (internal link). The first dial telephone began operation in 1896. The automatic dial system changed telephony forever. There were four great overlapping eras in telephone development: Invention, Crank, Dial, and Handset. They went from 1876 to 1893, 1877 to 1943, 1919 to 1978 and 1924 to the present respectively.

The vacuum tube ushered in the electronics age for telephony. In 1900, loading coil came into use patented by Professor Michael I. Pipin, loading coils helped improve long distance transmission. In 1906, Lee De Forest invented the three-element electron tube,

which had very good amplifying properties. It led the way to national phone services. The Bell telephone laboratory later made the triode, an amplifying electron tube work for telephony. The triode in particular and vacuum tube in general later made possible radio-telephony, microwave transmission, radar, television and hundreds of other technologies. A triode is sometime called a thermionic valve. Thermions are electrons derived from a heated source. A valve describes the tube properties and current flows in one direction only. Just like a faucet, a type of control valve, letting water go in only one direction. This controlled flow of electrons, not just electricity itself marks the end of the electrical age and the beginning of the electronic age. As evidence of triode success in telephony, on January 25, 1915 the first transcontinental telephone line opened between New York City and San Francisco.

It would be seen that since Alexander Graham Bell invention of the telephone in 1876, so many other inventions and innovations have greatly improved the telephone and made it what its is today. Telephone-Operated Night Light is one of such inventions.

1.3 PROJECT OBJECTIVES AND JUSTIFICATION

The objective of this project is to reveal the possibility of extending the functionality of the telephone (in this case telephone-operated night light), from just the tradition use of the telephone as a means of conversing between two individuals separated by distance to the control of the lighting system at the receiver's end.

The project reveals that the telephone is not just a device for talking for someone far from us but can also serve as a control switch, for turning a lamp ON and OFF when connected to the telephone-operated night light circuit at the receiver's end.

We all know that is one thing that is associated with waking up with heavy eyes. In such state one is bound to hit or bump into something in the room as a result of looking for switch to turn the light ON.

This project is justified in that it takes care of the accident, which might occur in the room as a result of waking up with the eyes heavy to answer a phone call by illuminating the room. For such reason, one does not need to look for switch because the telephone-operated light circuit will turn the light ON.

CHAPTER TWO

2.0 DESIGN ANALYSIS

2.1 OPTOISOLATOR

An opisolator, also known as an optical coupler or optocoupler, is a semiconductor device that allows signal to be transferred between circuits or system, while keeping those circuits or system electrically isolated from each other. Opisolators are used in a wide variety of communications, control, and monitoring systems.

Optoisolators, or opto-couplers, are made up of a light-emitting device, and a light sensitive device, all wrapped up in one package, but with no electrical connection between the two, just a beam of light. The light emitter is nearly always an LED. The light sensitive device may be a photodiode, phototransistor or more esoteric devices such as thyristors, triac etc.

The cheapest kinds have phototransistors. Below is a basic circuit diagram using one of these types used in the design of telephone-operated night light.

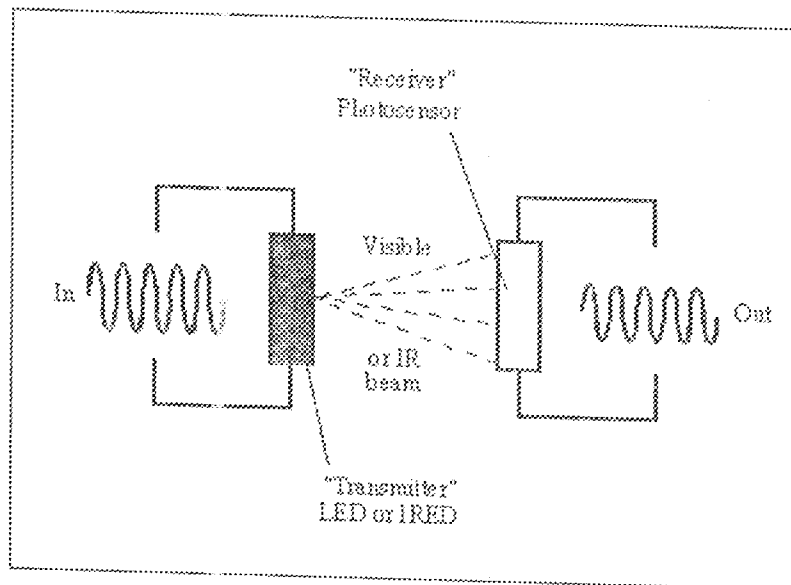

FIG 2.0 OPTOISOLATOR

2.2 THE DETECTOR CIRCUIT

In telephone-operated night-light, the ringing tone from telephone is needed. The ring circuit must pass the signal information to night-light and still provide electrical isolation between telephone line and night-light. This ring detection is usually done using one optoisolator circuit, which replaces the traditional ring circuit. The optoisolator output can be easily connected digital electronics components, but the optoisolator input side needs more electronics component: one capacitor for not letting DC to pass through optoisolator LED and one reverse connected diode in parallel with optoisolator LED to prevent negative voltages from damaging the LED. This is the basic ring detection circuit.

Usually there are also two zener diodes to make sure that the ring detection circuit does not detect too small AC signals in the line as ring signal. In the picture below you see a

typical ring detector circuit for night-light. The circuit just gives the idea how night-nights rings detector circuit work. The actual component value selection must be so that the circuit meets the national telephone regulation (this can be usually easily done by using suitable zener diodes and maybe changing the resistor value a little.)

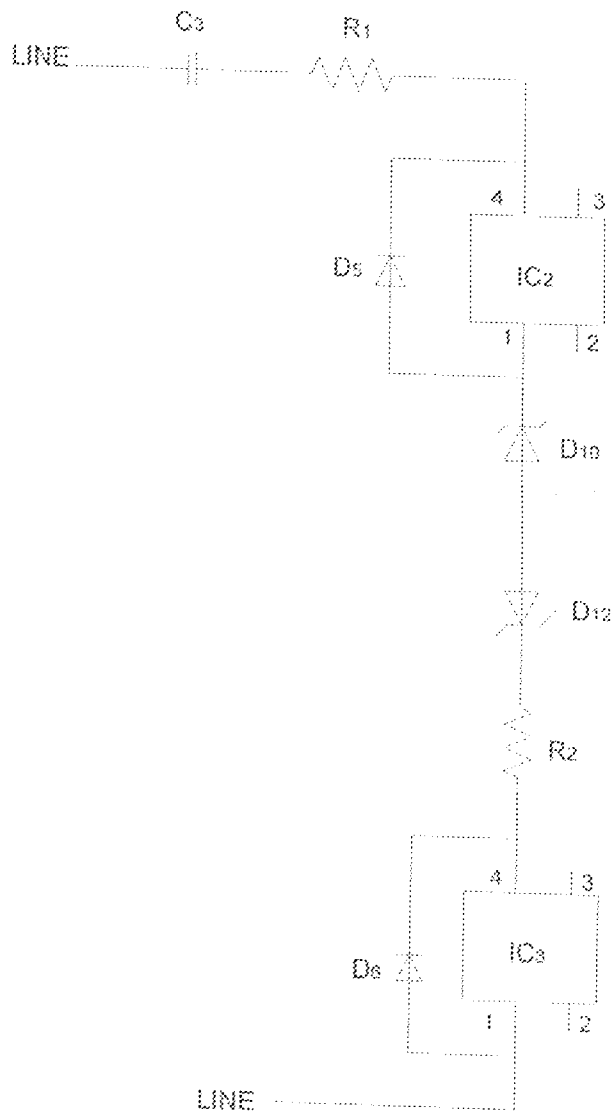

FIG 2.1 THE DETECTOR CIRCUIT

2.3 THE PROCESSOR CIRCUIT

This circuit consists of a dual timer NE556 IC_{4a}, a transistor, 1M variable resistor, 15K, 22K and 100K resistors all connected to the first timer in the NE556 and also connected to NE556 is 10uf capacitor. This first timer processes the signal coming into it in that sufficient base voltage from the phototransistor of the optoisolator triggers the transistor ON. The timer is triggered as a result of the capacitor discharging and the potential at pins 2 and 6 dropping to earth. The output of the timer Changes State (goes high) which then switches ON the transistor at the auto switch circuit. The auto processor circuit is shown below.

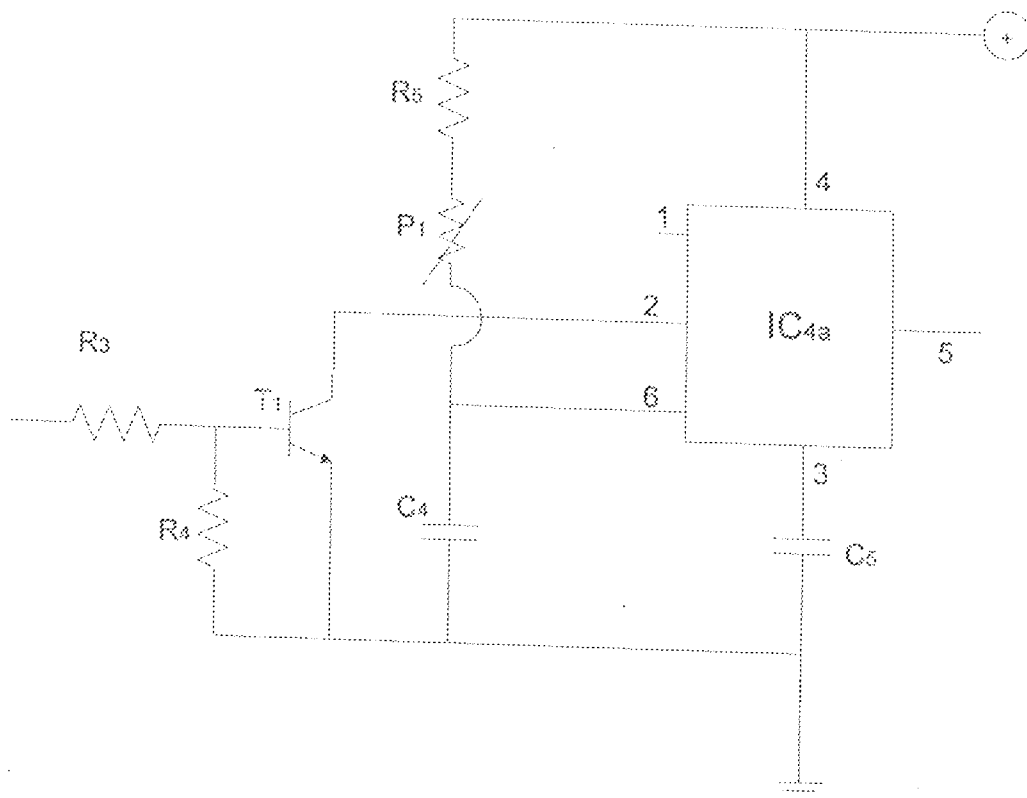

FIG 2 2 AUTO PROCESSOR CIRCUIT

For the manual processor circuit, the second timer in the NE556, IC_{4b} is used for manual operation of the lamp. Before it is triggered half the supply voltage exists at pins 8 and 12. The output (pin 9) is low so that C₇ cannot be charged. When S₁ is pressed, the trigger voltage briefly drops below the threshold, whereupon the output goes high. Since, owing to the constant R₉C₇, the potential across C₇ rises only gradually the level at the trigger input (pin 8) remains below the upper threshold. When the switch is operated again, the full level at the trigger input exceeds the upper threshold. The timer output then goes low again and the lamp goes out. The circuit is as shown below.

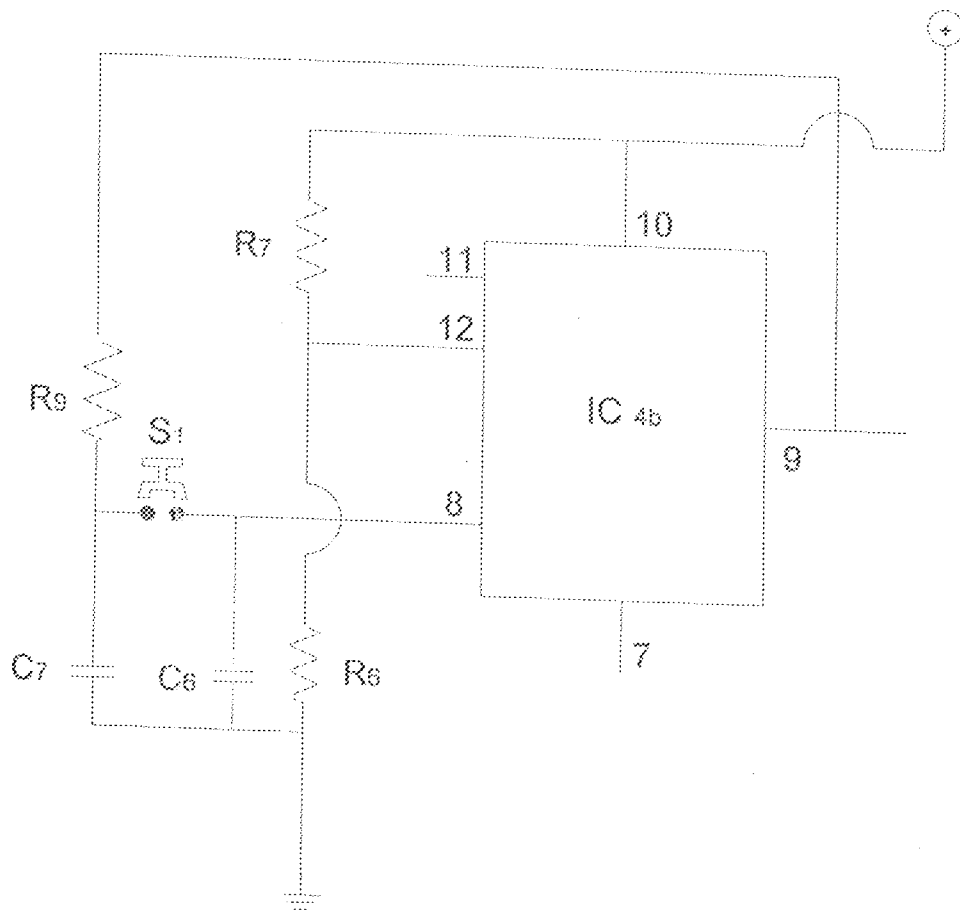

Fig. 2.3 MANUAL PROCESSOR CIRCUIT

2.4 THE AUTO SWITCH CIRCUIT

The auto switch comprises of BC547 transistor, diode, relay 10K and 15K resistors.

The transistor, which is switched ON as a result of the timer being triggered, energizes the relay, which acts as a magnet and then pulls the switch i.e. closes the switch to light up the lamp. Below is the diagram.

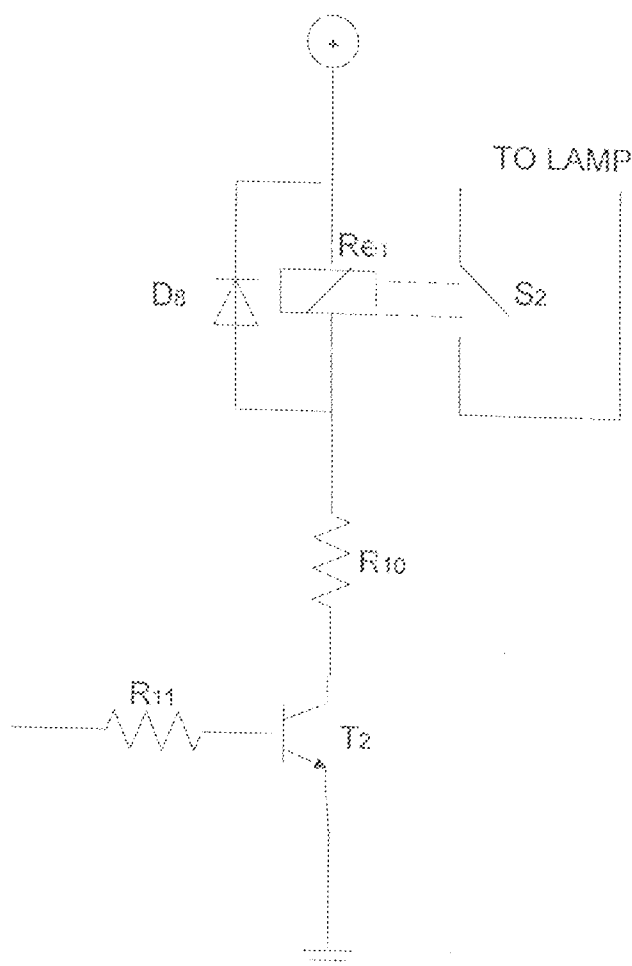

FIG. 2.4 THE AUTO SWITCH CIRCUIT

2.5 THE POWER UNIT

The designed of power unit supply consist of 12 volts transformer, relay, regulation and rectifier unit.

The power unit is designed with 12 volts transformer so as to produce both positive and negative voltage required for the input of the operation of the auto tamp.

Since full wave rectifier is needed, bridge rectifiers are connected to the secondary terminal of the transformer and smoothing capacitors of values 470uf, 25v and 470uf, 16v are connected across positive terminal of the bridge rectifier. The IC 7806 connected after the smoothing capacitor is to regulate the output voltage at 8v and the relay helps in the change over of power supply.

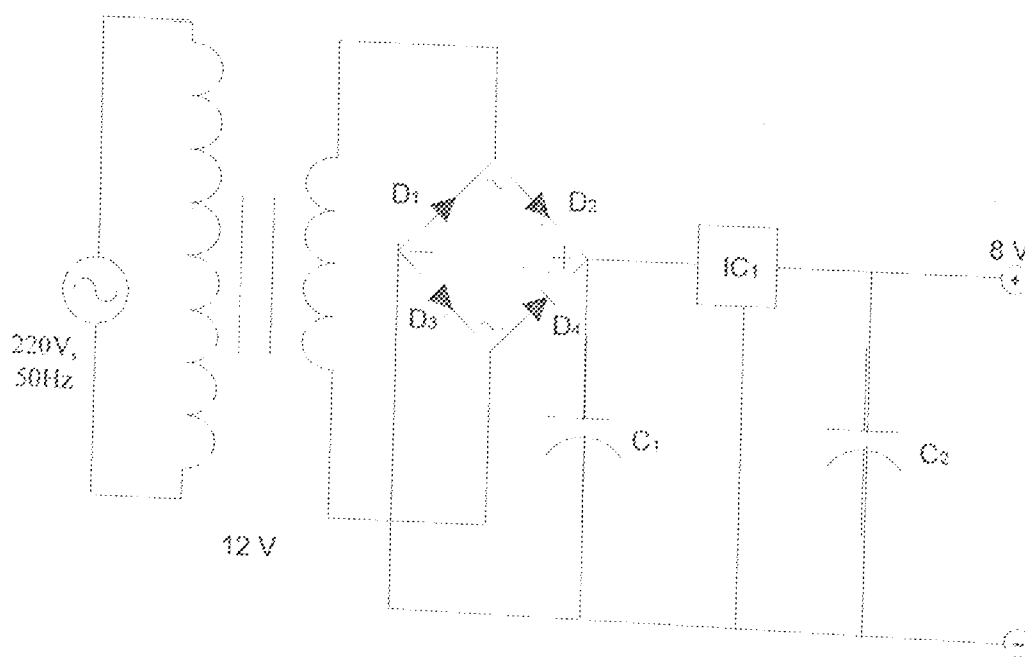

FIG 2.5 THE POWER UNIT

2.6 PRINCIPLE OF OPERATION

In most telephone networks, a direct voltage of 48-60v exists at terminal a and b. When the call signal comes in, a 50-60v alternating current at a frequency of 25-27 Hz is superimposed on the direct voltage. This open-circuit voltage is more than halved when the receiver is taken from the hook (which closes the currents loop). The current in the loop is 20-100ma. The present circuit starts a timer when it detects the call signal. The timer energizes relay Re_1 and this switches on lamp La_1 . After the last ring, the timer remains on for a short time, but then returns to its quiescent state, whereupon the lamp goes out. When, however, the receiver is taken from the hook, the timer is triggered permanently, so that the lamp remains on during the telephone conversation and for some time afterwards. Furthermore, the lamp may be switched on and off manually by S_1 being pressed.

One part of the circuit is connected in parallel, and the other in series, with telephone terminals a and b. The parallel connected part, which detects the call signal is isolated from the direct voltage by C_3 . Because of this, no current flows through the LED of optoisolator, IC_2 . So that the phototransistor is OFF. The second optoisolator, which is in series with a and b lines, also carries no current since the circuit is broken by the cradle switch.

The call signal, however, is applied to IC_2 via C_3 . Consequently, a current flow through the LED and the transistor is ON. The current is limited by R_1 , while diodes D_2 and D_3 chop the peaks off both the half waves to prevent any damage to the optoisolator.

The phototransistor provides sufficient base voltage to T_1 to switch ON this transistor. Capacitor C_4 discharges, whereupon the potential at pins 2 and 6 of timer IC_{4a} drops to

earth, which triggers the timer. Its output changes state (goes high). Whereupon T_2 is switched on so that the relay is energized. The relay contact connects one of the mains lines to lamp L_1 . The time constant of the timer has been arranged so that even the longest intervals in the call signal can be bridged. If the receiver is not lifted, and the last call signal has passed, the lamp remains on for the duration of the time constant and then the circuit returns to the quiescent state.

When the receiver is lifted off the hook, a circuit flows through the LED in IC_3 , whereupon the phototransistor in the optoisolator and consequently T_1 is switched ON. The timer is triggered as long as the telephone conversation lasts. When the receiver is replaced into the cradle, the lamp stays on for a short while determined by the setting of P_1 .

The circuit diagram and its block diagram are as shown below.

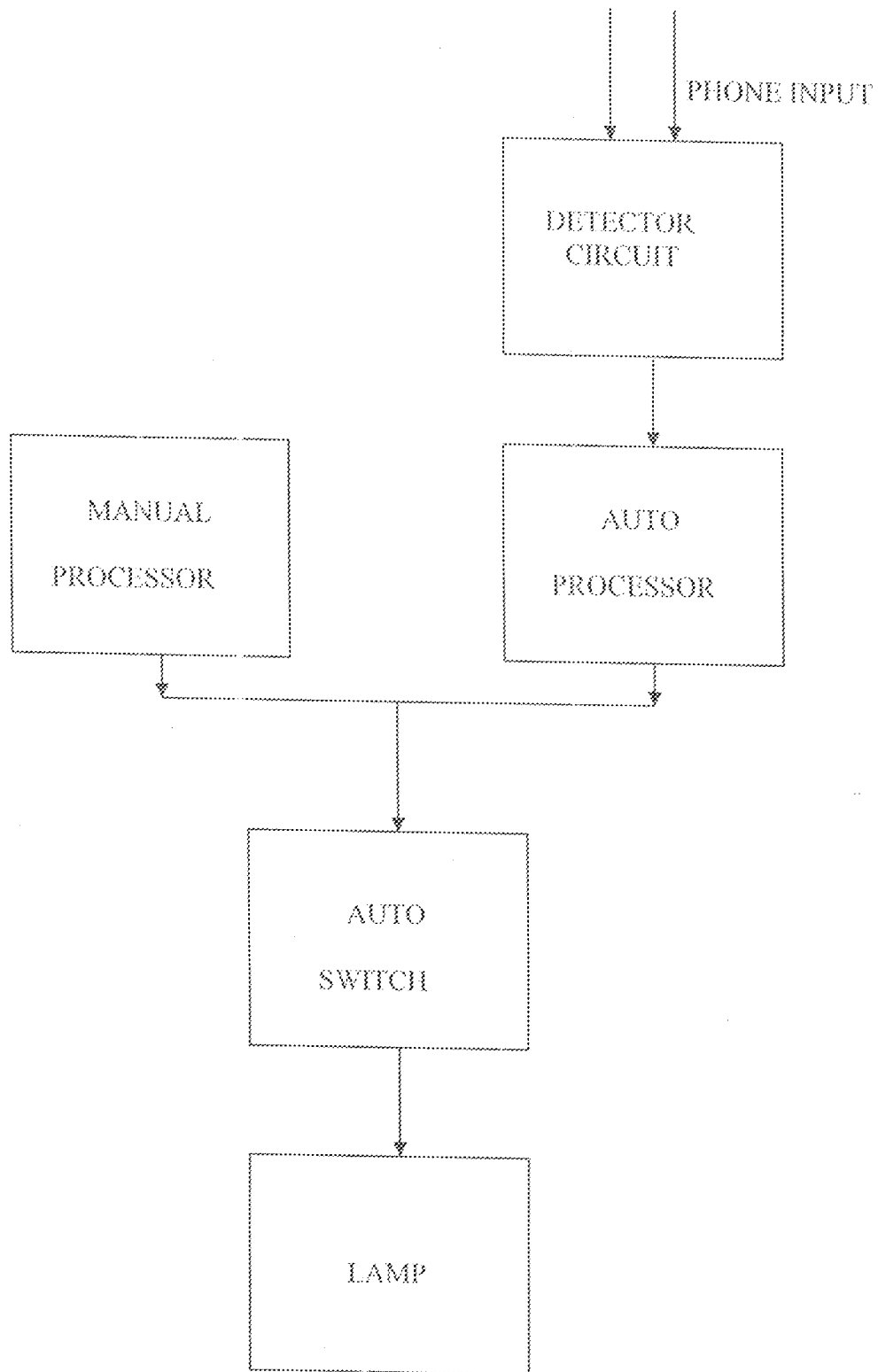

FIG.2.1 BLOCK DIAGRAM OF TELEPHONE-OPERATED NIGHT LIGHT

2.7 CONSTRUCTION

The construction was carried out in stages from one unit to the other using a breadboard or testing board where each section of the design was built and tested to give the required signal output. The power unit provides a 12v D.C. volt as the power supply.

The power unit was the first to be tested on the breadboard followed by the detector circuit and then the processor circuit. The auto switch, which has relay, was the last to be built and the testing of the whole circuit was completed. The lamp came ON as it was tested and the whole circuit was transferred from the breadboard to the Vero board using lead and soldering iron.

2.8 CALCULATIONS

From the frequency of oscillation, it is given that

$$F = \frac{1.44}{(R_1 + 2R_2)C_1} \dots\dots\dots (1)$$

Where

F = frequency of oscillation of timer

R₁ = Fixed resistor

R₂ = Variable resistor

C₁ = Coupling capacitor

From the circuit diagram of Fig. 2.0

$$R_1 = R_3 = 100 \text{ K}$$

$$R_2 = R_4 = 1 \text{ M}$$

$$C_1 = C_2 = 10 \mu\text{F}$$

Therefore,

$$F = \frac{1.44}{(R_s + 2P_1)C_d} \dots\dots\dots (2)$$

Since

$$F = \frac{1}{T}$$

Where T = Period and from equation (2)

$$F = \frac{1}{T} = \frac{1.44}{(R_s + 2P_1)C_d}$$

$$T = \frac{(R_s + 2P_1)C_d}{1.44} \dots\dots\dots (3)$$

And substituting the values into equation (3)

$$T = \frac{[(100 \times 10^3) + 2(1 \times 10^6)] (10 \times 10^{-6})}{1.44}$$

$$T = 14.58 \approx 15 \text{ Sec}$$

$$T = 15 \text{ Sec}$$

CHAPTER THREE

3.0 CONSTRUCTION AND TESTING OF THE PROJECT

The practical aspect of this project work involved the fixing of these components as shown on the circuit diagrams on the breadboard these were carefully pinned down and connected using flexible cables to link terminals and ends of components.

The essence of this breadboard circuit is to know the workability of the project and make one or two connections made as appropriate. Power supply to the system was initially supplied through an adapter at 12 volts and then a telephone line linked in to see how the system responds to incoming call signals. These preliminary testing will ensure a hitch free construction on the Vero boards, which will be done in replica with the breadboard arrangement.

3.1 POWER UNIT

The power unit is made up of two sources of power supply i.e. AC and DC.

The Ac comes through a 1.6m long flexible power cord. The power cord terminates into a center tap 12 volts transformer where two terminals were fed into a bridge rectified circuit comprising 4n diodes.

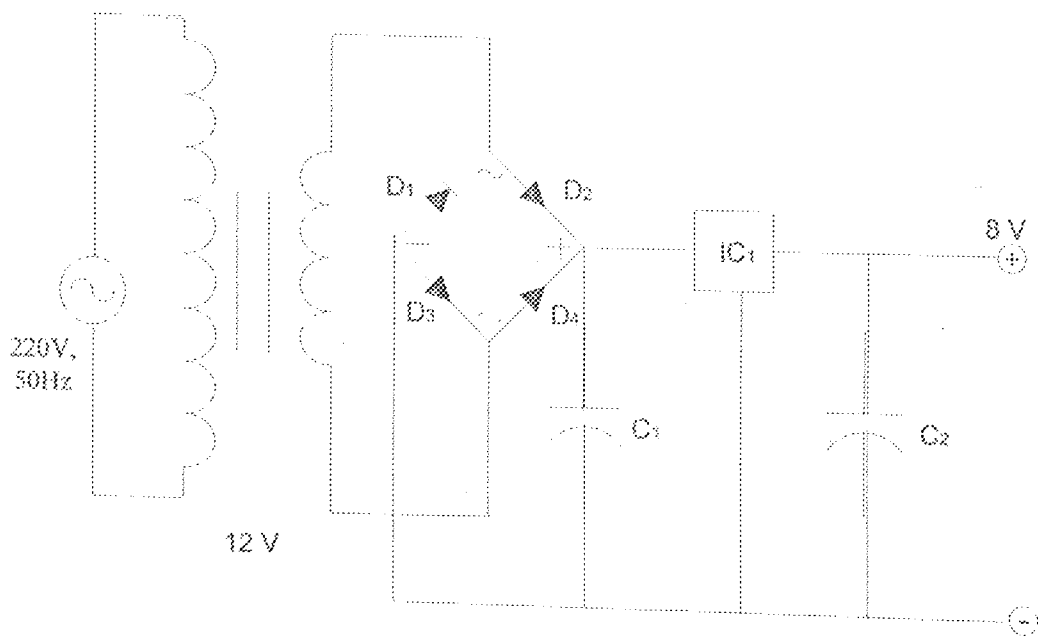

FIG. 3.0 POWER UNIT

As illustrated above fig 1 is used to power the whole circuit carrying out the function of the project for the purpose of automatic working of the project, a 6 volts relay change over switch has been employed to change the power unit from Ac to Dc automatically when there is power failure from main supply. The circuit is designed in such a way that the input fed into a relay is continually switched on to Ac power unit, but when there is power failure from mains, the relay contact from the Ac unit looses and thus rest back on the Dc power unit, until when the mains supply is restored, the transformer powers the relay again to loose contact with the Dc and reestablish Ac power supply to the circuit. In this circuit, a power supply to the system is always established.

3.2 CONSTRUCTION OF OTHER MAIN UNITS.

The construction of the main operation units started by fixing the whole components on the Vero board starting with all the ICs used. They were well spaced on the Vero board so as to ensure easy dissipation of heat and to allow fixture of other ancillary components. The components were fixed bearing in mind the continuity of the lines linking them beneath. Components adjoining each other were so arranged as to reduce the possible number of "jumpers" bridge cables, but these were however used where necessary.

When components like ICs are soldered, their bases beneath must be properly checked and conductor links adjoining opposite pins must be cut off using a modeling knife or a sharp cutting tool like razor blade.

The construction of this project was done and the following precautions were born in mind.

- i. All cables linking to mains supplies were insulated i.e. all exposed terminals properly insulated.
- ii. Hand gloves were worn when soldering to prevent accidental contact of the hot soldering iron with the body
- iii. The soldering iron was always switched off when not in use to prevent its damage and of course to conserve energy.
- iv. There was adequate care taken in soldering of all semi-conductors to avoid damage due to overheating. The class of components includes diodes, IC and transistors.
- v. Also the polarities of capacitors, diodes were well observed and soldered.

- vi. Also the pins of all ICs were read correctly starting from the right hands side of the marked face pointing the observer

3.3 TESTING

After all the components were put in the circuit board and soldered, current was not just supplied for testing, but rather a meter was used to read the resistance of the whole project. This was in order to verify whether the circuit resistance as tested was in harmony from that established from design calculations. This procedure was also useful as it aided in determining the amount of current to supply to the unit to drive its working efficiently.

3.4 TESTING FOR WORKABILITY

The whole circuit was linked to mains telephone line and a mobile handset was used to dial the concerned line. This test and observations are as recorded below.

TABLE 3.0 DESIGNING AND TESTING OF PROJECT

TEST	OBSERVATION	INFERENCE
Digital metal set at ohms and connected to project terminals.	Resistance read was 152Ω.	The value of resistance shows the result of the construction is accurate because calculations give value of the resistance of 148Ω.
Project linked to telephone mains and call to line done with mobile phone.	The lamp glowed and brightens up as call got through, after which the bell in the phone rang.	This shows that project is adequately built and all components responded as required.

3.5 CASING

The shape of this projected adapted is a recessed rectangular box, which shall be made up of lightweight encasing material like plywood or strawboard. The use of wood glue is highly recommended in joining parts of the case, as this will reduce number of nailed

exposed joints. When strawboard is used however, the surface should be well finished with embossed paper to give it a better face lift.

Lamp (1st built)

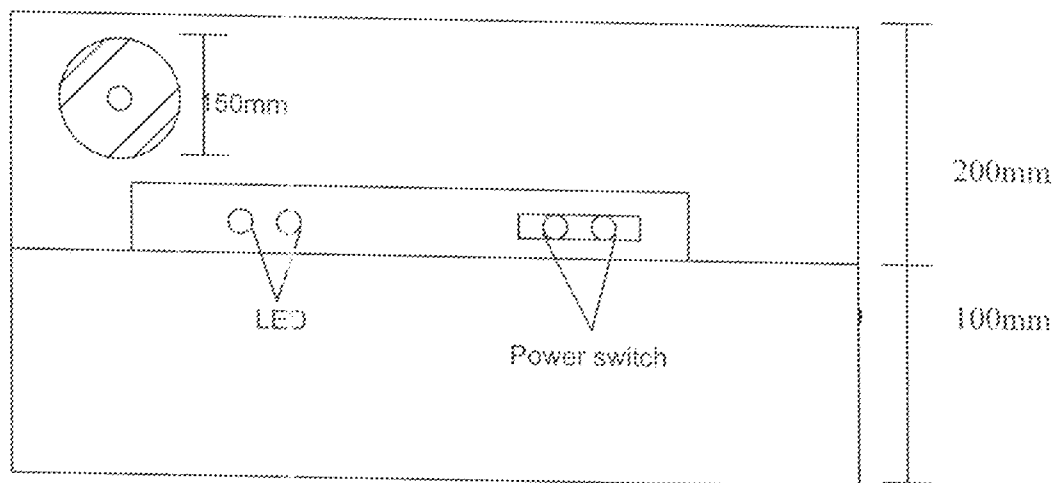

Front Elevation

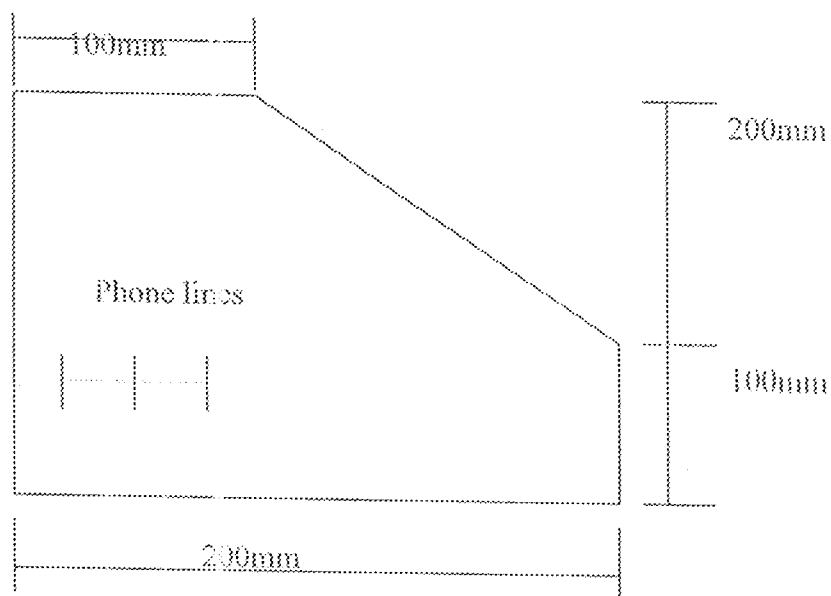

Fig 3.1 CASING OF THE PROJECT

CHAPTER FOUR

4.0 CONCLUSION AND RECOMMENDATIONS

4.1 CONCLUSION

This project work was a complete success which showed that the telephone can also be used to turn ON light i.e. a control switch for a lamp. However, This project is simply a model.

4.2 RECOMMENDATIONS

Having taken you throughout the introduction to the design and construction of this project, I want to draw the following recommendations.

- These units can be manufactured on a larger scale and sold to the populace owing to its economic and social importance in a home
- I also recommend that further research work should be carried out to make only one lamp to be used in this system.

REFERENCE

1) Electronic products (design and make it)

By:

-Dave Bell

-Philip Poole

-Tristram Shepard

ISBN 0 7487 2473 7 (1996)

2) Telecommunications Principles and Systems

By:

-Y.A. Adediran (1997)

ISBN

3) Engineer Mini-Notebook 555 Circuits

By:

-Forest M. Mim (1984)

ISBN

APPENDIX

ITEM NUMBER	DESCRIPTION	TYPES
D ₁ -D ₄	IN4001	RECTIFIER DIODE
D ₅ -D ₆	IN4148	DIODE
D ₁₀		PHOTODIODE
D ₁₁ AND D ₁₂	3V	ZENER DIODE
C ₁	470 μ f	FIXED CAPACITOR
C ₂	10 μ f	"
C ₃	470 μ f	"
C ₄	10 μ f	"
C ₅	10nf	"
C ₆	1 μ f	"
C ₇	10 μ f	"
R ₁	15K	FIXED RESISTOR
R ₂	350 Ω	"
R ₃	15K	"
R ₄	22K	"
R ₅	100K	"
R ₆	620K	"
R ₇	620K	"
R ₈	360K	"

R_9	47K	"
R_{10}	50 Ω	"
R_{11}	10K	"
T_1 AND T_2	BC 547	TRANSISTOR
Re_1	RELAY	
P_1	1M	POTENTIOMETER
S_1	PUSH BUTTON SWITCH	
S_2	MAKE CONTACT SWITCH	
a AND b	PHONE LINES	
La_1	LAMP	
IC_1	7806	
IC_2 AND IC_3	CNY 65	
IC_{4a} AND IC_{4b}	NE 556 (DUAL TIMER)	
K_1	PHONE LINE PORT	
K_2	LAMP HOLDER	
M	TELEPHONE SET	