

DESIGN AND CONSTRUCTION OF AN AUTOMATIC CHANGE OVER SWITCH

UGOCHUKWU IZUELUMBA

2004/18891EE

**A Thesis Submitted To The Department Of Electrical And
Computer Engineering, Federal University Of Technology**

Minna.

DECEMBER 2009

DEDICATION

The project is dedicated to the Almighty God who saw me through my course of study, especially at this final stage.

Also to my parents, I love you all.

DECLARATION

This is to certify that this project (automatic change over switch) was carried out by UGOCHUKWU IZUELUMBA under the supervision of Engr. BALA and submitted to the department of Electrical and Computer Engineering of Federal University of Technology Minna, for the award of Bachelor of Engineering (B. ENG) degree in electrical and computer Engineering.

UGOCHUKWU IZUELUMBA

.....

Student

 08/02/10

Signature and Date

ENGR. BALA. A. SALIHU

.....

Supervisor

08/02/10 

Signature and Date

 ENGR. DR. Y. A. ADEDIRAN

.....

(H.O.D)

May 6, 2010

Signature and Date

.....

External Examiner

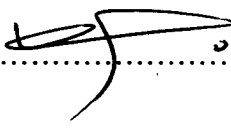
 09/03/10

Signature and Date

ACKNOWLEDGEMENT

Thanks to Almighty God who made it possible for me to carry out this project work successfully.

My profound gratitude goes to my parent Sir and Lady James okafor for their dedicated effort to see me through my academic pursuit, may God in his infinite mercy bless them abundantly (amen).

My special appreciation goes to my supervisor Engr Bala for his assistance, recommendation, suggestion etc during my project work. I also say thanks to the department and the entire lecturers in the department, for the knowledge they impacted in me.

My final gratitude goes to my beloved friend Dera Daniels who supported and me in so many ways, may God bless you all.

ABSTRACT

Power failure or outage in general does not promote development to public and private sector. The investors do not feel secure to come into a country with constant or frequent power failure. These limit the development of industries. In addition there are processes that cannot be interrupted because of their importance, for instance surgery operation in hospitals, transfer of money between banks and lots more. This paper presents the design and construction of an automatic power changeover switch that switches power supply from public supply to generator once there is public power supply outage and it does this automatically. This is achieved by the use of integrated circuits that have timing abilities and relays to effect switching.

TABLE OF CONTENT

CONTENT	PAGE
Title page	i
Dedication	ii
Declaration	iii
Acknowledgement	iv
Abstract	v
Table of contents	vi
List of figures	ix
Chapter one: Introduction	
1.1 General Introduction	1
1.2 scope and limitation	2
1.3 Aims and Objectives	2
1.4 Methodology	3
Chapter Two; literature review	
2.1 Introduction	4

2.2	Historical Background	5
2.3	Theoretical Background of the project	7
2.4	Target Area	10
Chapter three: Design and Implementation.		
3.1	Circuit Design Analysis	11
3.2	Power Supply Unit	12
3.2.1	Transformer	13
3.2.2	The Rectifier	14
3.2.3	The Filtering Capacitor	14
3.4	The Control Unit	17
3.4.1	The 4060B Timer	18
3.4.2	The 4013B Latches	21
3.5	The Indicator	24
3.6	The Switching Unit	25
3.6.1	The Relay	26
3.6.2	The transistor unit	27
3.7	Motor Terminal	29

3.8 Battery Connection 29

3.9 Output Load 30

Chapter four: Test and Discussion of Result

4.1 Test 31

4.2 Result 32

4.3 Discussion of Result 32

4.4 Trouble Shooting 33

Chapter five: Conclusion and Recommendation

5.1 Conclusion 34

5.2 Recommendation 34

References 35

LIST OF FIGURES

Fig 2.1: Diagram of Regulated power supply.....	7
Fig 2.2: Electromagnetic Relay.....	8
Fig 3.1: Block diagram of the system.....	12
Fig 3.2: Circuit of power supply unit.....	13
Fig 3.3 Transformer.....	13
Fig 3.4: Filtering capacitor.....	14
Fig 3.5: Power circuit.....	17
Fig 3.6: Pin Assignment of 4060B.....	19
Fig 3.7: RC mode of the 4060B.....	20
Fig 3.8: D-Type latch at SR mode.....	22
Fig 3.9: Indicator Circuit.....	24
Fig 3.10: A Relay.....	26
Fig 3.11: Transistor circuit.....	27
Fig 3.12: Two 6 volts Batteries connected in series.....	29
Fig 3.13: System circuit diagram.....	30

CHAPTER ONE

INTRODUCTION

1.1 GENERAL INTRODUCTION

Power instability, interruption, failure or outage is common in developing countries like Nigeria, Togo, Ethiopia etc, and it does not promote development to the private and public sections.

Majority of the commercial and industrial process including some domestic processes, depend on uninterrupted power supply. In an event of power interruption or instability, the change-over from power supplied by public utility (PHCN) to a generator is usually performed manually, which often result in time wasted; moreover machine damage can sometimes occur due to human error. These and many more can cause significant financial losses. Therefore it is important that the electrical power produced at the source and delivered to the load be adequate and uninterrupted. [1]

The project is designed for power supply application. It involves automatic change-over between the main power supply (PHCN) and an auxiliary power supply such as generator. The project implements an automatic switching or starting of a generator wherever the main power supply fails or the voltage is too high or too low.

The basic operation is to switch on an auxiliary power supply (generator) it connects the power supply from the generator to the load after a predetermined time so as to normalize the current from the generator. The starting of the generator is done by a relay which swishes the battery voltage to the ignition coil of the generator, while the main power relay swishes the load to either public supply (PHCN) or generator.

This project has been designed to automatically interchange power supply the moment the A.C main (PHCN) is restored and switch off the generator. At this point the device removes the streets of switching on and off the generator manually when the A.C main fails or is restored. The design of this project take into consideration, practice or real life situation.

1.2 SCOPE AND LIMITATION

The project focus on the construction of a device that automatically switches to an auxiliary power supply immediately the supply from PHCN is not available. The load remains connected to the auxiliary supply as long as the auxiliary supply (generator) is in good condition and it switches back once the AC main is restored. It is designed for domestic, industrial and commercial use.

1.3 AIMS AND OBJECTIVES

The projects Improves the availability and the efficiency of electric energy consumption in such a way that the design devices a normal output voltage continuously.

The project is aimed at designing and construction of an automatic change-over switch. The device functions by changing over or switching power between the A.C mains and the auxiliary power supplies.

The project is also maimed to enable user to minimize change over time and also prevent danger associated with manual change over switches.

1.4 METHODOLOGY

The method employed in this project is to carry out the design of individual modules which are then coupled into a single whole circuit in order to satisfy the overall objective of the project

The Sub-Circuit Are

1. The power supply unit
2. The indicator unit
3. The logic control unit
4. Change over switch unit

The design methodology follows the steps above. The design considered the availability of suitable component at reasonable cost.

CHAPTER TWO

LITERATURE REVIEW

2.1 INTRODUCTION

Developed nations have uninterrupted power supply, but in developing countries there is power failure or outage. A country like Nigeria is accustomed to unstable power supply. It is only wise to provide a building with an auxiliary power supply as an alternative to the main power supply because the main power supply could fail. Most buildings have power standby such as gasoline or diesel generator and power inverter to that effect.

In most developed countries there are huge facilities that provide electricity. These generate substantial amount of electricity for consumer and industries through gas. Nuclear, solar technologies etc. On the contrary, Nigeria's power generation is based mainly on the hydroelectric dams which have proven not to be substantial for the consumers. As a result the overall load is greater than the available power. This leads to constant or frequent power outage or load shedding.

Electricity is very essential in our daily activities thereby people turn to auxiliary generator due to unstable power in the country. The availability is a problem on its own because at times it is either too low or too high and either of these can damage appliances (especially when it is too high), much less its stability. Consumers still connect their appliances to the A.C mains because it is expensive to maintain generator. The importance of an automatic change over unit is the interchanging from one source to the other not depending

on the user's manual. The procedure is automated and manual enhancements are incorporated to the device in the case of emergency.

2.2 HISTORICAL BACKGROUND

Power change-over are sometimes inclusive in the buildings electrical wiring. One of the known contributors to electricity was Benjamin Franklin who proved lightning is electricity and invented the lightning rod in 1752 [2]. Another was George Ohm who postulated the Ohm's law ($V=IR$). Yet another was the development of a bulb in 1879 by Thomas Edison [2]. He also established the first power plant in 1881 [2].

The first standard of commercial electricity supply was made in 1897 known as the electric code [3]. The first successful hydropower project was in the Niagara Falls in the USA [2]. In the beginning of the twentieth century, different companies in the USA started manufacturing and development of electric building wiring devices, such as the cutter manufacturing company located in Philadelphia and the National Electric Company (NEC), they produced electric element such as circuit breakers, fuse boxes, power dangers and lots more [3]. Their technologies were based on modern electronic controls.

Kon Doh and Tovoshi from Japan in 1975 patented a unique change-over type loading assembly which was designed for non utility power generators. They were installed in high rise buildings or other facilities in order to deal with situations such as power failures [3]. This invention was concerned with a loading device assembly for dry type testing equipment in which series of resistors made of metal member used for testing purpose without regards for water resistance. The invention was quite significant. But it does not employ advantages of modern electronics.

a manual change over switch consists of manual change over switch box, switch gear box and the connector fuse or cut out fuse. this change over switch box separate the source between the generator and P.H.C.N. and when there is power supply outages, from P.H.C.N. somebody has to go and change the line from P.H.C.N. source to generator thus when P.H.C.N. power supply is restored somebody has to go and put off the generator and then change the source line from generator to P.H.C.N.

The switch is used to protect the equipment of the generator as well as that of the building. This shows that if there is high voltage from P.H.C.N. when supply, the fuse inside the switchgear will cut off, this separates the supply from the load. This also does the same when there is high voltage from the generator. The cut - out fuse is an additional protector of any high voltage between P.H.C.N. a source and switchgear.

In view of the above manual change over switch that involves manpower by using one's energy in starting the generator and switching over from over P.H.C.N. to generator and vice - versa when the P.H.C.N. supply is being restored; the urgency attached to cases of operation in hospital in order to save life from danger by getting the supply from generator as fast as possible, gave the zeal to design and construct an automatic change over switch which would solve the problem of manpower and the danger likely to be encountered during operations in hospitals

2.3 THEORETICAL BACKGROUND OF THE PROJECT

the theoretical background of this project is based on the principles of a regulated power supply, a relay operating principle.

As shown in the figure below, a regulated power supply make use of a step down Transformer, rectifying circuit, and a filtering capacitor.

The transformer steps down the ac supply voltage to suit the requirement of the electronic devices and circuits fed by the dc power supply. it also provides isolation from the supply line an important safety consideration. The rectifying circuit (bridge type) employees the use of a chip to convert ac voltage into pulsating (called ripples) present in the output voltage supplied by the rectifier o course, a filtering capacitor is used to remove the ripples.

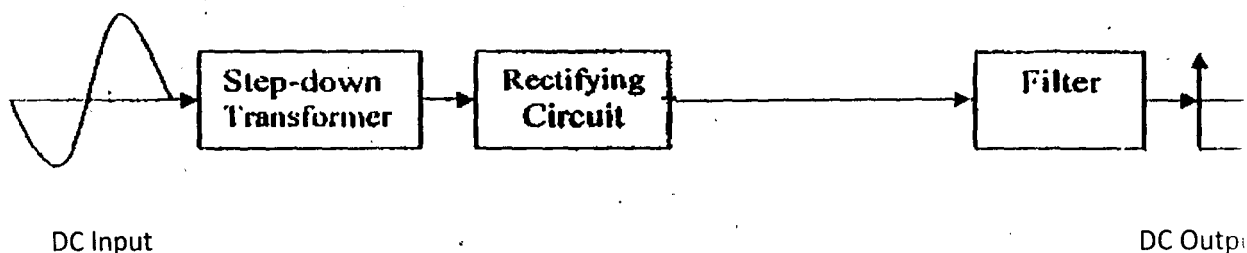

fig.2.1 lock Diagram of the Regulated Power Supply.

The relay operating of the project section operates based on the principle of electromagnetic induction. However, a general purpose relay (used) is basically a mechanical switch operate by a magnetic coil similar to that of the figure below, the general purpose relay employed her a DC type. These relays are available with coils that can operate or close the contacts from m volts to the hundred volt range. Relays with a 6, 12, 24, 18, 115, and 230volts design are the

most common. Today designs offer a number of general purpose relays that require as little as 4milliamp at 12v DC making them IC compatible to TTL and CMOS logic design (gates). These relays are available in a volt range of switching configuration [2, 3, 4, 5, 6, and 7).

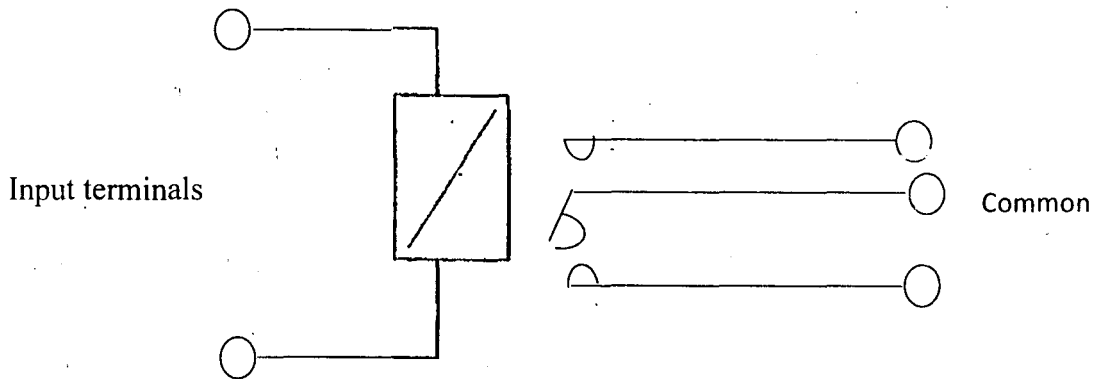

Fig 2.2 Electromechanical Relay

The current needed to separate a relay is called the pull - in current and drop - out current is the current the coil when the relay just stops working. If the coil resistance is R and its operating voltage is V , the pull-in current.

The primary purpose of the DC voltage source is to supply power for lighting the LED and ignition of the generator. The LED converts electrical energy into light energy (as a transducer). It is used as an indicator. The resistor in series with the LED limits the current through the LED by directing and controlling current, making changing currents produce changing voltage and obtaining variable voltages from fixed ones. The value of the external resistor in series with the LED is calculated as follows:

Where: R is the use of the resistor

V_s is the supply voltage

V_f is the forward voltage of the diode

If is the forward current of the diode

The arrangement of the capacitor and the relays is used to ensure the ignition time of the generator using the voltage supply from the secondary. This ignition time is the transient time or time constant of a capacitor as it charges or discharges through a resistor (i.e. the resistance of the relay). This can be calculated or determined using this relationship that follows:

$$T = CR,$$

Where: T is the time constant of the capacity

C is the capacitance of the capacitor

R is the resistance of the relay

2K

Note: V_s - — after time $T/3$

V_c is the capacitor voltage

V is the supply voltage of the secondary.

2.4 TARGET AREA

(1). Power supply is essential in our day to day activities. There are a lot of operations that should not be interrupted, operations like: surgery, incubators for babies e.t.c

(ii). Use in Banks.

(iii) Network server rooms

(iv) GSM Operators

CHAPTER THREE

DESIGN AND IMPLEMENTATION

3.1 CIRCUIT DESIGN ANALYSIS

The total circuit of the project is divided into the following units

1. Power supply
2. Generator supply unit
3. Control unit
4. Switching unit.
5. Output.

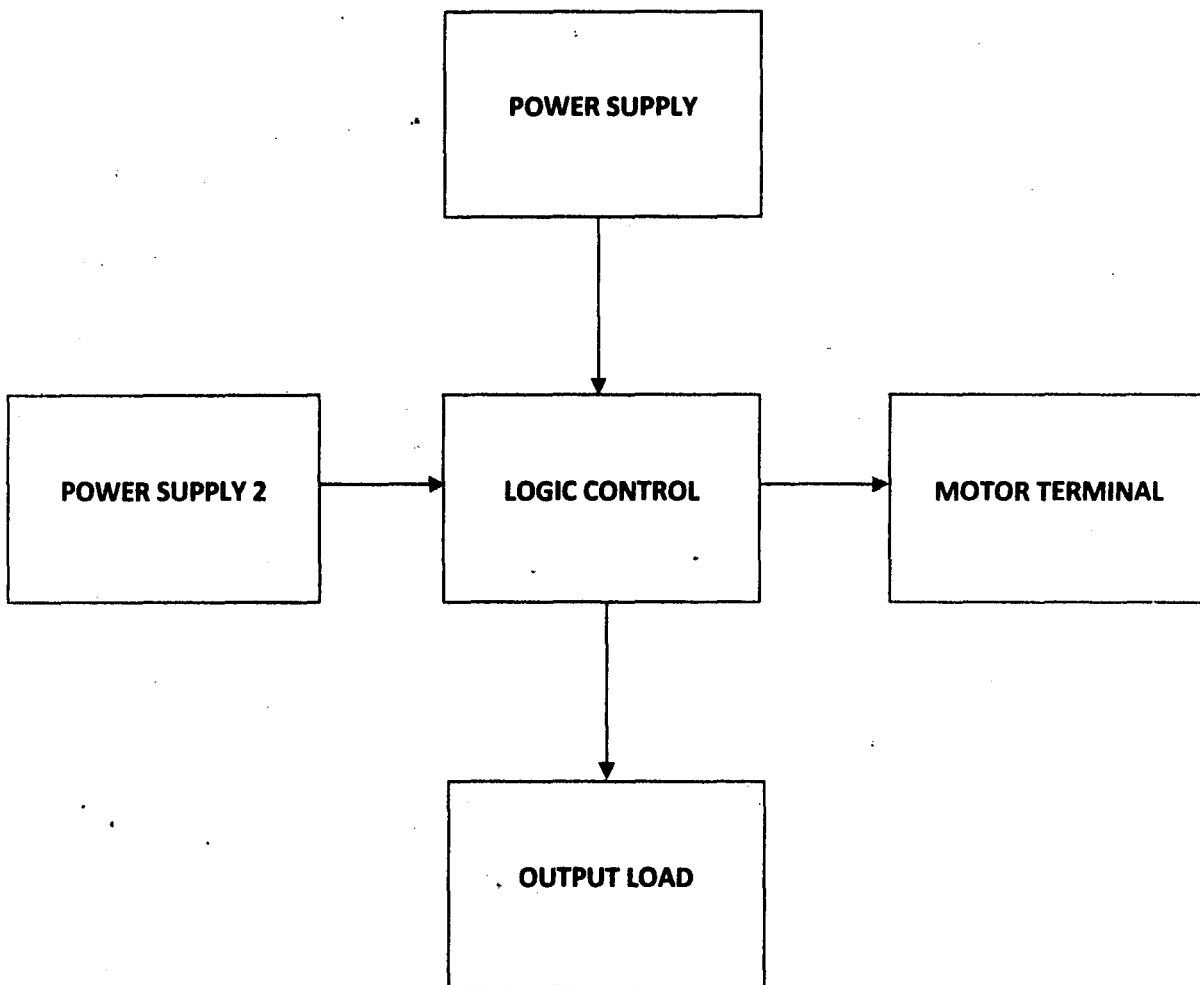

Fig 3.1 The block diagram of the system

3.2 POWER SUPPLY UNIT

This consist of three sub-units namely, 12V step-down transformer, a rectifier (bridge) and a filtering capacitor. The transformer steps-down voltage from 220V to 12V (AC), this is then wired to a bridge rectifier which converts the AC signal to DC signal. The DC that was obtained has some ripples which were filtered out via a filtering capacitor. The filtering capacitor is usually an electrolytic capacitor. The circuit describing this unit is shown below

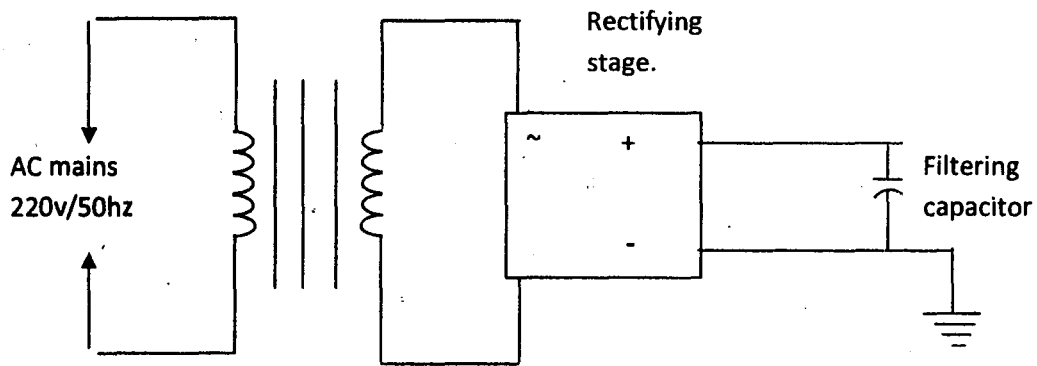

Fig 3.2. Circuit of Power Supply Unit.

3.2.1 THE 12V TRANSFORMER

The 12V transformer, rated 500mA, is incorporated into the circuit to drop the voltage from 220V to 12V. The 12V specification is needed to allow reliability of the circuit at low input power supply. AC output of the transformer is fed to a rectifying/filtering circuit for conversion to DC.

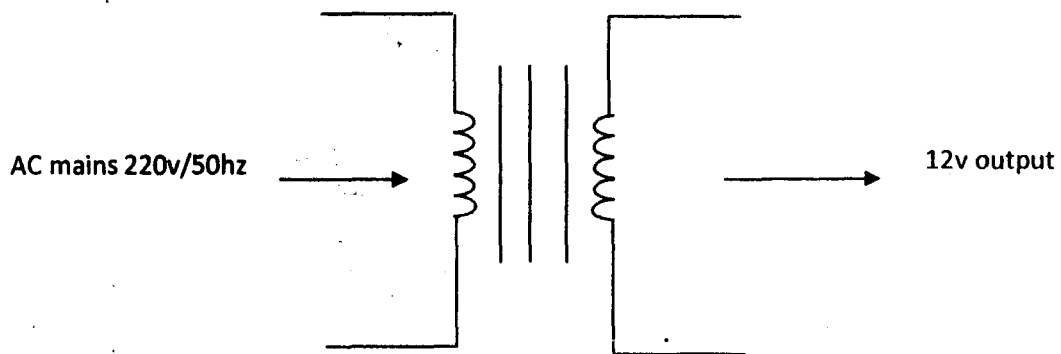

Fig 3.3 Transformer

3.2.2 THE RECTIFIER

The commonly used four (4) diodes were not used in this case. A single chip label KBJ6688 64G was used in place of the diodes. It also does the work of the four diodes (i.e. the rectification or conversion of the AC to DC).

3.2.3 THE FILTERING CAPACITOR

The output from the rectifier is expected to be fully DC, but this is not always true [9]. The voltage after rectification still contains some ripple, (a signal of small component of the AC input). The way of removing the unwanted feature is the use of a polarized or electrolytic capacitor. A 1000 μ f type is the choice for the project because any relatively higher value than this will cause delay in switching of connected relays due to longer discharge resulting into slower power changing over.

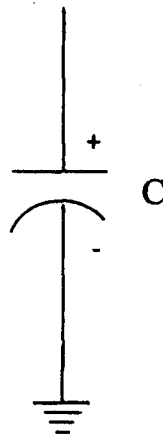

Fig 3.4 Filtering Capacitor

Mathematical analysis of choosing C1

$$Q = It = cdv$$

$$It = cdv$$

$$C = It / dv$$

But $dv = \text{peak voltage} - V_{\text{minimum}}$

$$\text{Peak voltage} = \sqrt{2} \times V_{\text{rms}}$$

$$V_{\text{rms}} = 12\text{V}$$

$$\text{Peak voltage} = \sqrt{2} \times 12$$

$$= 16.97\text{V}$$

A silicon material was used; therefore $0.7 \times 2 = 1.40$ is subtracted from the peak voltage.

$$\text{Total peak voltage} = 16.9 - 1.4$$

$$= 15.5\text{V}$$

Since 12V relay used can work with minimum of 10V, then $V_{\text{minimum}} = 10\text{V}$,

$$\text{Therefore } dv = 15.5 - 10 = 5.5\text{V}$$

$$I = \text{Current of the Transformer} = 0.5 \text{ Amps}$$

$$t = \frac{I}{F}$$

$$\text{There } T = 2t = 1/4$$

$$= \frac{1}{100} = 0.01$$

$$100$$

$$C = I \times F = \frac{0.01 \times 0.5}{dv}$$

$$5.5$$

$$C = 909 \times 10^{-6}$$

$$C = 1000 \mu\text{F}$$

3.3 GENERATOR SUPPLY UNIT

This unit is merely all about the alternative power supply which can come from an electric generator. Its power output is connected to the charge over switch.

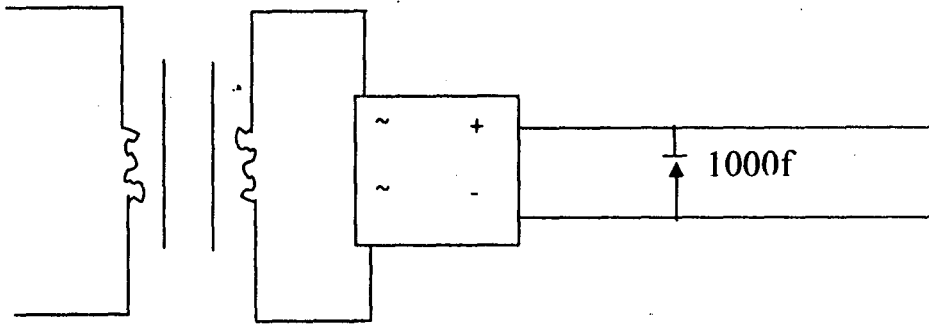

Fig 3.6 power circuit

3.4 THE CONTROL UNIT

The control unit is the heart of the whole circuit; its operation is based on sequential timing. The main component of the unit is a control oscillator (4060B). This device initiates the required switching in the circuit. Although, the device has ten control terminals, only two are used in the circuit for controlling the latches. It is designed to execute the following tasks after a relay connects to power from a 12V battery.

1. To disconnect the load from the normal AC mains through a relay immediately the power fails.
2. It triggers on the starter motor for about three seconds.
3. Switches on a relay that connects the power from the generator to the load.

3.4.1 THE 4060B TIMER

The 4060B in fig 3.4.1 is a 16-pin CMOS (complimentary metallic oxide silicon) RC/crystals oscillators/divider integrated circuit. It is designed to generate ten different frequencies from a particular one, and is usually configured in the RC mode [5].

Its pin 12 is required logic zero or ground for normal operation. Pin 9, 10 and 11 are output 1, output 2, and clock terminal, respectively [7]. They are needed for the RC oscillator mode. The device works with 3-18volts power supply.

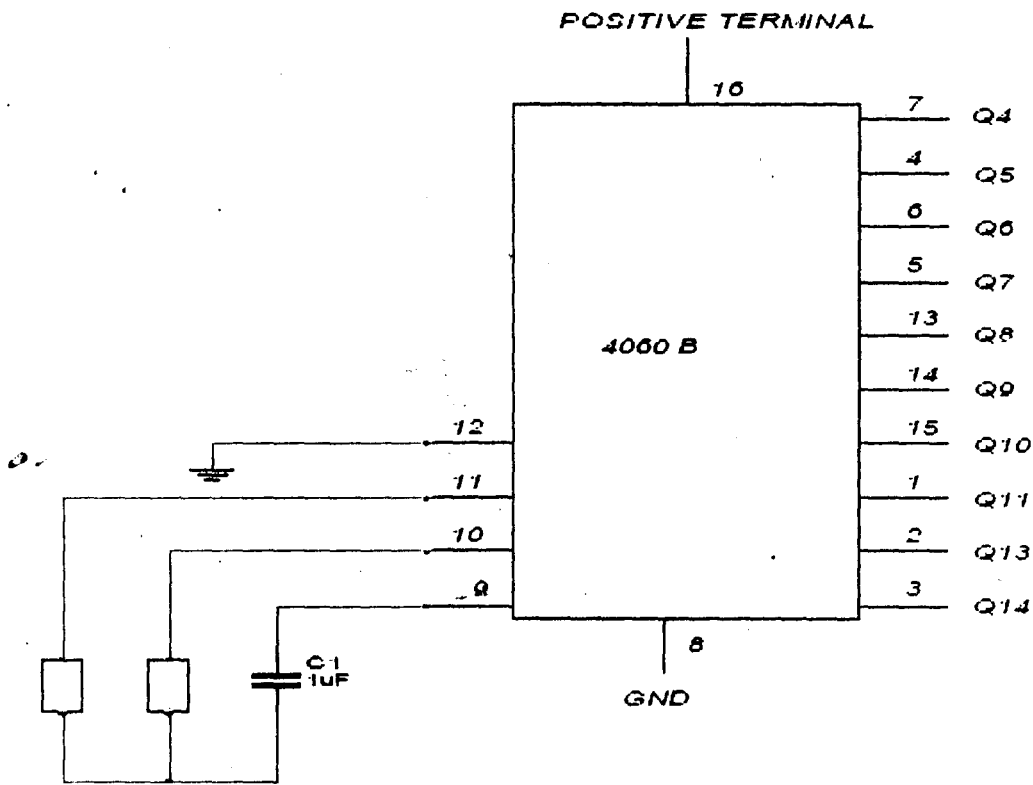

Fig 3.6 The Pin Assignment of 4060B

The values on that are preceded by Q are the Q values talked about earlier in this chapter.

It is used to calculate the value of the frequency of each pin.

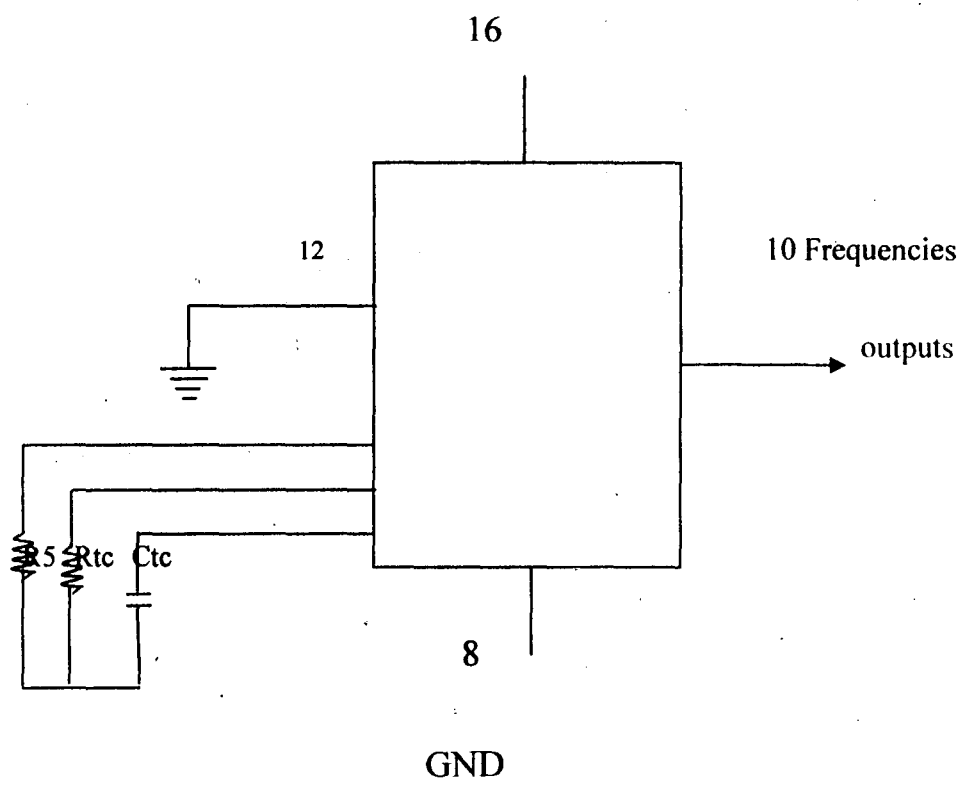

Fig 3.7 the RC mode of the 4060B

The 10 output signals are derived from a main frequency. The main frequency of oscillation is given by [7].

$$f_m = \frac{1}{2.3R_{tc}C_{tc}}$$

Where $10R_{tc} \geq R_5 \geq 2R_{tc}$

The typical values of R_s , R_{tc} and C_{tc} are $100K\Omega$, $33K\Omega$ and $0.001\mu F$.

There $f_m = 1/2.3 \times 33 \times 10^3 \times 0.001 \times 10^{-6}$

$$f_m = 13.2KHz$$

These signals are used for switching or controlling the latches which deal with motor and change over control.

3.4.2 THE 4013B LATCHES

The 4013B integrated circuit contains two independent latches. They work with active high signals. Although the 4013B is really designed for D type application, the latches in the circuit are configured in the SR mode by grounding the corresponding clock and D inputs as shown in the fig below. The circuit requires two of this latches one of the latches controls relay two (2) that switches ON and OFF the motor/starter. The other latch handles the change over operation between the public power supply and the auxiliary power to a particular load.

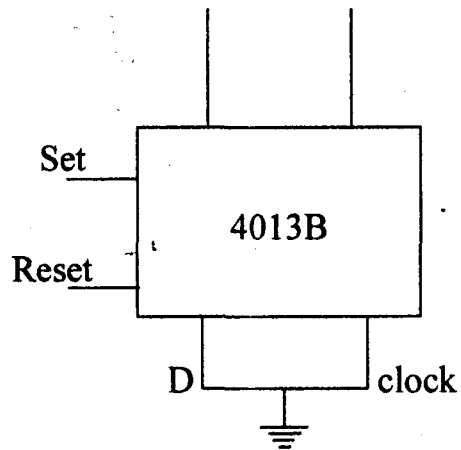

Fig 3.8 A D-Type Latch at SR Mode

The output frequencies are based on the following formula

$$F_{qx} = F_m / 2^x$$

Where: - X is the Q value of a corresponding pin (4)

Frequency output from pin 2 is given by

$$F_{q^{13}} = \frac{F_m}{2^{13}}$$

Where 13 is the corresponding Q value of pin 2

$$\frac{13.2 \times 10^3}{2^{13}}$$

$$F_{q^{13}} = 1.61 \text{ Hz}$$

$$Tq^{13} = 1$$

$$\frac{1}{Fq^{13}}$$

$$Tq^{13} = 1$$

$$\frac{1}{1.61}$$

$$= 0.62\text{sec}$$

$$= 1\text{sec}$$

Frequency output from pin three (3) is given by

$$Tq^{14} = Fm$$

$$\frac{1}{2^{14}}$$

Where 14 is the corresponding Q value of pin three (3)

$$Tq^{14} = \frac{13.2 \times 10^3}{2^{14}}$$

$$2^{14}$$

$$= 0.81\text{Hz}$$

$$Tq^{14} = 1$$

$$\frac{1}{Fq^{14}}$$

$$= \frac{1}{0.81}$$

$$0.81$$

$$= 1.23\text{sec}$$

$$= 2 \text{ seconds}$$

3.5 INDICATOR

This circuit comprises of a red light emitting diode (led) and a current limiting resistor which is connected in series with the led. The resistor allows voltage drop of about 1.70 across the device. It is incorporated into the design to indicate whenever then the circuit is active. The resistor allows a voltage drop of around 1.7V across the light indicator. The circuit of the system is shown below.

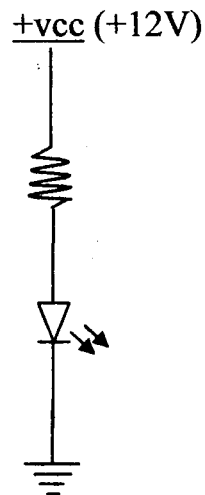

Fig 3.9 indicator circuit

$$V_{LED} = 1.7V$$

$$I_{LEDMAX} = 20mA$$

$$\text{Let } I_{LED} = 10mA$$

$$R = \frac{V_{CC} - V_{LED}}{I_{LED}}$$

$$= \frac{12 - 1.7}{10\text{mA}}$$

$$= 1030$$

$$= 1\text{k}\Omega$$

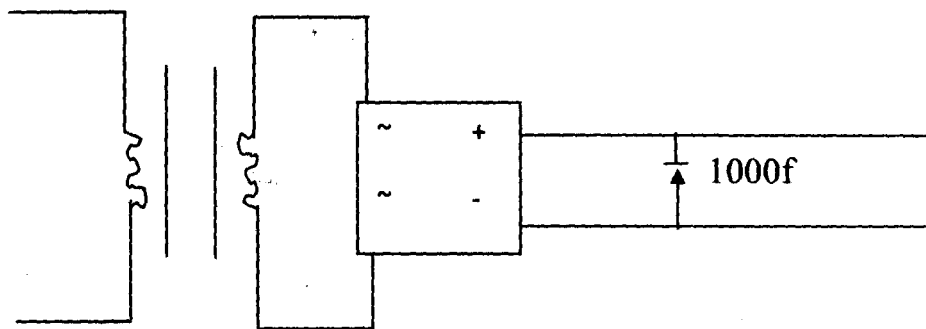

Fig 3.6 power circuit

3.6 THE SWITCHING UNIT

This unit consist of the component that aid in the switching process. They include; the relay and the transistors

3.6.1 THE RELAY

This is an electromagnetic device, it consist of a coil which current passes through. In the process an electromagnet is formed, this then helps to move the common from its position to another position. It is used by varying the input in order to get a desired output. Relays are of two types, the normally closed and normally open. [11]. The type used in this project is the normally open relay.

A relay switch is also used for switching heavy load in AC, the load rating depends on the current specification of the device. The type in this circuit is rated 12V and 10A. Therefore, if the voltage involved in switching is 220V AC, the maximum power loading is around 2Kw. A normal relay has 5 terminals [9], three of them serve the switching connection, the other two are used for inductive switching of the relay

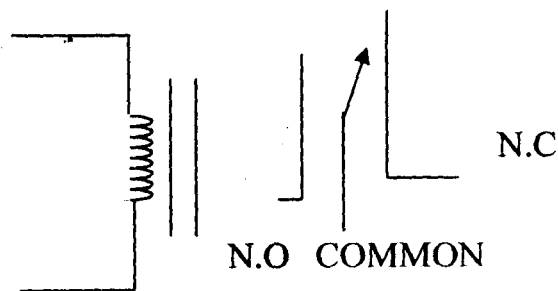

fig 3.10 A relay

Two relays are used for change-over operation and one more for switching a battery to the control circuit.

3.6.2 THE TRANSISTOR UNIT

It is a good and common practice to switch relay with a transistor. The transistor is set in the common emitter configuration. (Operating at saturation and cut-off region).

The switching transistor used is 25c 945 it is an NPN device with maximum current and voltage ratings at 100milliamperes and 50volts. It possesses a typical current gain of 100. The resultant load or resistance of the relay in the transistor collector is 400Ω [4]. Therefore for full saturation of the transistor, the bases of the switching transistor are connected to the latch through a $2.2k\Omega$ resistor. The mathematical analysis of that value is shown below.

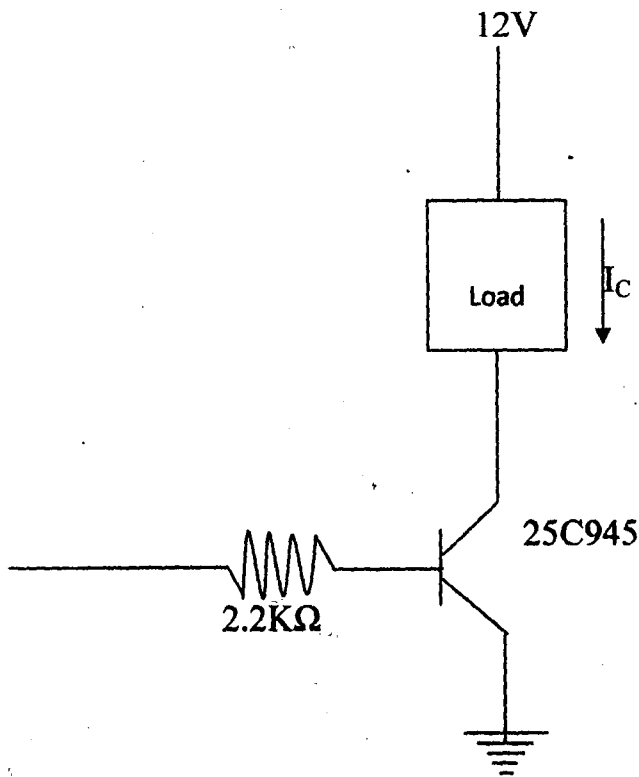

Fig 3.11 transistor circuit

From data sheet $I_C = 100mA$

$$h_{fe} = 100$$

$$V_{CC} = I_C R_C + V_{CE}$$

But at saturation $V_{CE} = 0$

$$V_{CC} = I_C R_C$$

But $R_C = \text{Relay Resistance} = 400\Omega$

$$V_{CC} = 12V$$

$$12V = I_C \times 400$$

$$I_C = \frac{12}{400}$$

$$= 0.03A$$

$$= 30mA$$

$$h_{fe} = 10$$

$$h_{fe} = \frac{I_C}{I_B}$$

$$I_B = \frac{I_C}{h_{fe}} = \frac{30mA}{10} = 3mA$$

$$V_B = I_B \times R_B$$

$V_B = \text{output voltage Fwin } I_C$

$$= \frac{2}{3} \times V_{CC}$$

$$= 8V$$

Therefore $8 = 3mA \times R_B$

$$R_B = \frac{8}{0.003} = 2.7K\Omega$$

= 2.2K Ω

3.7 MOTOR TERMINAL

The motor is intended for an electric motor which starts an internal combustion engine that powers an alternator, since the project is prototype this terminal is connected to a 12V battery (two 6V batteries connected in series). When electricity is supplied to the terminal of the motor, it works within a short time then after a particular time which is controlled by the oscillator the engine (generator) switches ON.

3.8 BATTERY CONNECTION

The battery is what powers the motor of the generator or the whole change-over circuit once there is power failure. Both batteries are rated 4A

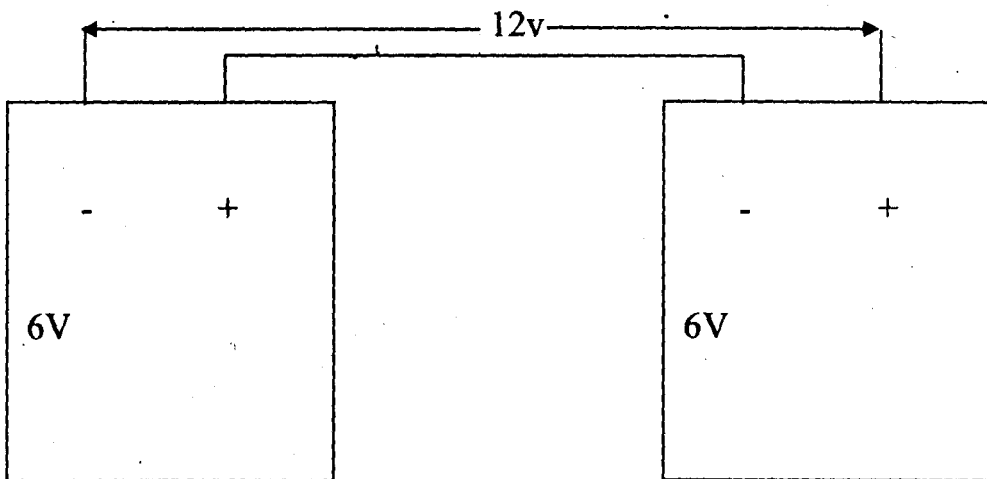

Fig 3.12 Two 6 Volts Batteries Connected in Series

3.9 OUTPUT LOAD

The load is just about the altogether electric connection to the power. A 60 watts bulb is used as the load. It indicates the presence of electricity at the output.

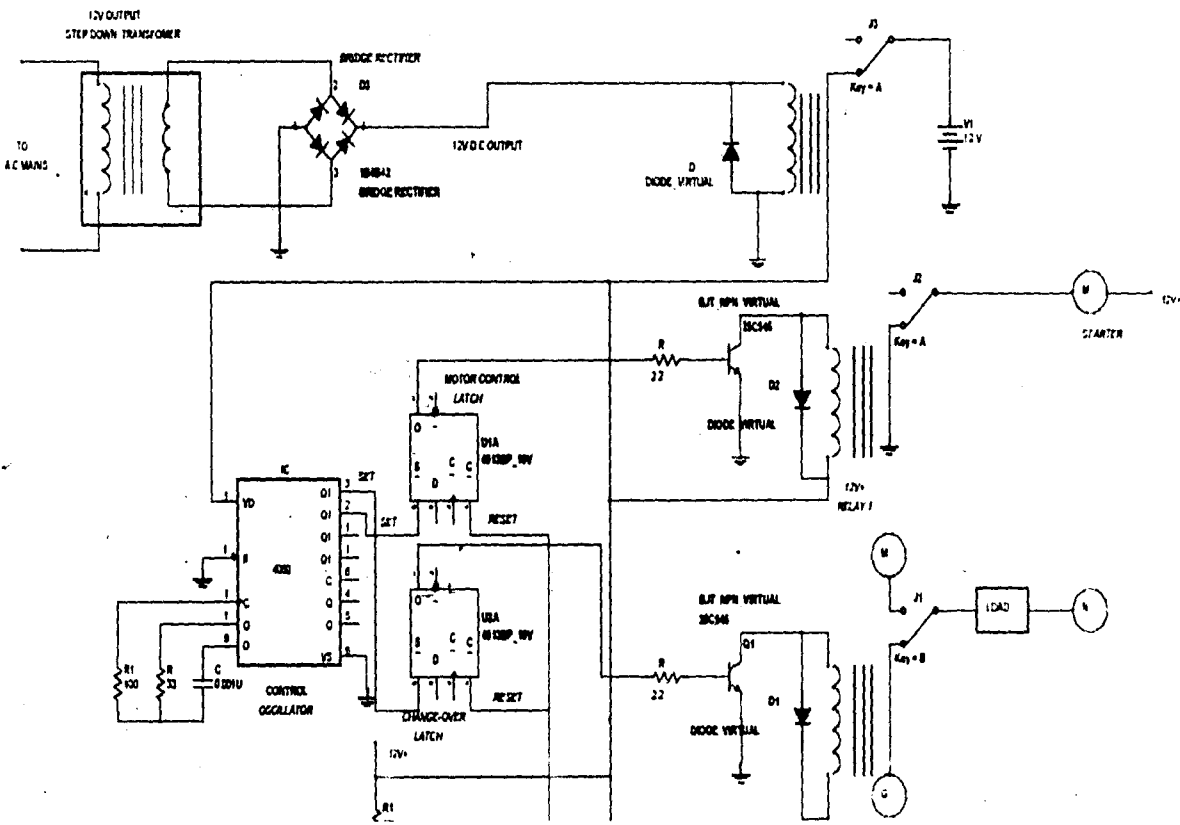

Fig 3.13 system circuit diagram

CHAPTER FOUR

TEST AND DISCUSSION OF RESULT

4.1 TEST

The testing of the project involved putting the set up with a wiring the battery to the circuit. The main control point was a single phase socket box. It involved two plugs respectively the Generator (A) and AC mains (B). The control of the device was done on socket box by putting in place and removal of the plug indicating supply from AC mains, leaving the one from the generator plugged.

The plug B (the AC mains) was removed from the socket, indicating there is no power supply from AC mains. Immediately the plug is removed, the motor indicating the starter of the generator kicks and goes off.

The plug that was removed from the socket (AC mains) was put back to indicate that the AC supply has been restored.

When both plugs were removed the circuit did not function, there was no power supply of any form.

4.2 RESULT

Unplugging both plugs and the battery from the terminal made the device useless. When the battery was properly fixed, and the control box's plugs were put in place, the bulb was on without any response from the electric motor with time. The condition remained the same.

Unplugging plug B (for the Ac mains supply) resulted into switching off of the electric bulb, and the motor (starter of the generator) rotated for a specified period of time about two seconds before going off, and after about five seconds later the electric bulb comes on again.

When plug B was plugged back into the control box, the bulb came on instantly.

When both plugs were unplugged from the socket the bulb went off, with no response from the electric motor. In fact none of the previous result was possible if the battery terminal were not properly connected in place.

4.3 DISCUSSION OF RESULT

When the two plugs were not in place the circuit yielded no result. The removal of the plug (B) allowed DC power supply to the circuit through a relay switch which connects the circuit to the incorporated 12V battery. The electric motor represents the normal starter for normal internal combustion engine of the generator. It is normally required to work for a short period of time in getting the engine started.

There was a delay of about three seconds after the electric motor stopped working, before the light came on again. The removal of plug A after the light comes on was to show that the source of electricity the bulb was through line A. The light went off in response to the removal of the removal of plug A. if the plug is put back in place the light should come on again. Plugging back plug B to the control socket allowed normal AC supply into the bulb. The comes on in a shorter while.

4.4 TROUBLE SHOOTING

The device worked properly after testing, but it was found to have a little delay in switching, so the timing was adjusted to avoid a long delay in changing over

CHAPTER FIVE

CONCLUSION AND RECOMMENDATION

5.1 CONCLUSION

An automatic power changeover switch has been designed and constructed. The prototype of the automatic power changeover switch worked according to the specification and quite satisfactorily. The device is quite cheap, reliable and easy to operate. Whenever there is power outage, it reduces stress for manpower changeover

5.2 RECOMMENDATION

1. Higher current capacity relay should be employed.
2. Timing circuitry could be incorporated into the design to allow different delay in switching.
3. With little modification a 3 phase power application of the circuit is possible.
4. The generator must be in good working condition so that the device can function properly.

REFERENCES

1. Gary Rockis and Glen Mazur, Electrical Motor controls. Automated Industrial Systems, American technical publisher, New- York, USA. 1987, pp241.
2. www.kspec.uk.com/technology/electronic/7806.html
3. Microsoft Encarta premium 2008 edition
4. Amos, S.W.; and James, M. 1981. Principles of transistor circuit: Introduction to the design of amplifiers, receivers and digital circuits, 6th ed., Hartnolls Ltd., Bodmin, UK.
5. Datasheet search system. Alldatasheet.com.
Available: <http://www.alldatasheet.com/>
6. Horowitz, P.; and Hill, W. 1995. The art of electronics, 2nd ed. Cambridge University Press, Cambridge, MA, USA.
7. Theraja, B.L.; and Theraja, A.K. 2002. A textbook of electrical technology, 21st ed., Rajendra Ravindra Printers (P) Ltd., S. Chand & Company Ltd., Ram Nagar, New Delhi, India.
8. Thomas, L.F. 1997. Digital fundamentals: Integrated circuits, 6th ed. Prentice-Hall, Englewood Cliffs, NJ, USA.
9. Theraja B.L. and Theraja.A.K, 1997. A Text book of Electrical Technology 4th ed S. Chand and company Ltd, New Delhi.
10. <http://www.datasheetachieve.com>
11. Texas instrument data sheets.