

# **DESIGN AND CONSTRUCTION OF AN ELECTRONIC SCHEDULE CHART.**

**BY**

**ALLIU ABUBAKAR GARBA  
(2001/11939EE)**

A Thesis submitted to the Department of  
Electrical and Computer Engineering, Federal  
University of Technology, P.M.B 65, Minna,  
Niger State, Nigeria.

**November 2007.**

## **DEDICATION**

This project is dedicated to Almighty Allah, the supreme of all being. It is also dedicated to my parents Mallam Waziri Alliu Garba and Hajiya Fatima Azumi Alliu for being my source of inspiration.

May the favour of Allah continue to be with you and make me a blessing to the family (Amin).

## DECLARATION

I, **ALLIU ABUBAKAR GARBA**, declare that this work was done by me and has never been presented elsewhere for the award of a degree. I also hereby relinquish the copyright to the Federal University of Technology, Minna.

Mr. Paul Attah

.....  
Name of Supervisor

 28/11/2007  
Signature and Date

Alliu Abubakar Garba

.....  
Name of student

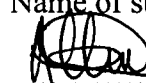
 28/11/07.  
Signature and Date

Engr. M.D. Abdullahi

.....  
Name of H.O.D.

.....  
Signature and Date.

.....  
Name of external Examiner

.....  
Signature and Date.

## ACKNOWLEDGEMENT

I give thanks to almighty Allah whom out of his infinite mercy saw me through the end of my degree programme in F.U.T, Minna. The peace of Allah also be upon our noble prophet Muhammad (S.AW), the seal of prophets and a role model to mankind who came to guide us through in this world.

My indefinite gratitude goes to my parents for their moral, financial and parental support during and after my programme, I say may Allah reward you with his paradise (Amin).

I wish to express my gratitude to Engr. Musa Abdullahi, the Head of Electrical & Computer Engineering Department, my Supervisor Mr. Paul Attah, other staff and my fellow colleagues for their constructive criticism and advice given towards the success of this project.

Special thanks goes to the the following people: Brother Tamadi, Mr Bukar Bashir, Baba Aisha karu, Alhaji Abubakar Akawo, Aunty Yagana, Alhaji Idris, Kachalla, Comrade Emereni Daniel and others who contributed in one way or the other to my academic success.

Finally, my acknowledgement goes to my priceless gem Ayinla Rukayyat Olajumoke, who stood by me up till date. May Allah reward you abundantly.

## **ABSTRACT**

The design and construction of an electronic schedule chart is achieved using the one – shot multivibrator, where the generated pulse is counted and its output decoded by a decoder so that the selected output from this decoder would be displayed by a light emitting diode. The essence of this project is to indicate to a visitor the where about of an occupant and close the communication gap between both parties.

This project is divided into five units, which are power supply unit, timing unit, binary counter unit, decoder unit and the indicator unit. These units were assembled together to achieve the desired objective.

## LIST OF FIGURES

- Fig 1.1: Layout of an Electronic Schedule Chart
- Fig 2.1: Two branches of Electronics
- Fig 2.2: General block diagram of an N – line – to –  $2^n$ - line decoder
- Fig 2.3(i): Circuit diagram of an SSI implementation of 1-of- 4 decoder
- Fig 2.3(ii): Symbol used for a SSI implementation of 1-of- 4 decoder
- Fig 2.4: Basic circuit of a LED indicator
- Fig 2.5: Practical circuit of a LED indicator
- Fig 3.1: Block diagram of the project
- Fig 3.2: Circuit diagram of the Power Supply
- Fig 3.3: Schematic symbol of the 555 timer
- Fig 3.4: One–shot Monostable circuit diagram
- Fig 3.5: Pin out of the CD 4520
- Fig 3.6: The Binary Counter configuration
- Fig 3.7: A 2-to- 4 line single bit decoder
- Fig 3.8: Pin out of the CD4514
- Fig 3.9: The interface between the Indicator LEDs and the decoder
- Fig 3.10: Complete circuit diagram of the Electronic Schedule Chart

## **LIST OF TABLE**

Table 2.1: Truth table of a 1-of-4 decoder

## **TABLE OF CONTENTS**

<b>Title</b>	<b>Page</b>
Dedication	ii
Declaration	iii
Acknowledgement	iv
Abstract	v
List of Figures	vi
List of Table	vii
Table of Content	viii

### **CHAPTER ONE: INTRODUCTION**

1.1 Preamble	1
1.2 Aims & Objectives	2
1.3 Methodology	2
1.4 Project Layout	3
1.5 Scope	3
1.6 Sources of materials and Constraints.	3

### **CHAPTER TWO: THEORETICAL BACKGROUND**

2.1 History of Electronics	4
2.1.1 Branches of Electronics	5
2.2 Literature Review	5
2.3 Principle of Operation	6



2.4 Theory of the Project	6
2.4.1 Monostable multivibrators	6
2.4.2 One-shot characteristics	7
2.4.2.1 Inputs	7
2.4.2.2 Retriggerability	7
2.4.2.3 Resettability	8
2.4.2.4 Pulse width	8
2.4.3 Counters	8
2.4.4 Decoders	9
2.4.5 Light-Emitting Diode	11
2.4.5.1 LED voltage and current	12
2.4.5.2 LED Brightness	13
2.4.5.3 Breakdown voltage.	13

## **CHAPTER THREE: DESIGN AND CONSTRUCTION**

3.1 Power Supply Unit	14
3.1.1 The IC Voltage Regulator	14
3.2 Timing Unit	17
3.2.1 One- Shot Monostable Unit	18
3.3 Binary Counter Unit	20
3.4 Decoder Unit	22
3.5 Indicator Unit	24

<b>CHAPTER FOUR: TESTS, RESULTS AND DISCUSSION</b>	
4.1 Testing of components, Units and Final Circuit	26
4.2 Results	27
4.3 Discussion of Results	28
<b>CHAPTER FIVE: CONCLUSION AND RECOMMENDATION</b>	
5.1 Conclusion	29
5.2 Recommendation	29
<b>REFERENCES</b>	31
<b>APPENDIX</b>	32

# CHAPTER ONE

## GENERAL INTRODUCTION

### 1.1 PREAMBLE

A Chart/Graph is a type of information graphic or graphic organizer that represents tabular numeric data and/or function. Charts are often used to make it easier to understand large quantities of data and the relationship between different parts of data. They can usually be read more quickly than the raw data that they come from. [6]

Before the invention of mobile phones/ telephones, it is difficult to communicate with one another. Information without being communicated is useless, that is why there is need to device means of communicating with people.

This project is designed to inform visitors or strangers the where about of a person at any particular or given time of visit. It will be horrible for a visitor to leave his/her own place just for a visit and become stranded at the occupant residence. The visitor(s) become tensed up due to lack of information, which is very important and necessary for a man.

Today, proper communication has made life easy and pleasant for people because they get what they want within some seconds. This project has to do with the generation of pulse when the switch is triggered at anytime. Pulse generated will be counted through the BCD counter and for each generated pulse, the Decoder decodes it. Each output from the decoder is connected to a LED, while the selected output is displayed by emitting light on the LED. The pulse is a one-shot/ monostable that goes high and comes back to low state.

Finally, these projects when placed on the door, will indicate/ inform the visitor(s) without any delay the where about of the occupant.

## **1.2 AIMS AND OBJECTIVES**

The major aims of this project are to:

- ❖ Inform the visitor(s) that the occupant is around/ not around.
- ❖ Indicate the where about of the occupant so that the visitor(s) don't keep waiting unnecessarily.
- ❖ Create a communication bridge between the visitor(s) and the occupant.

## **1.3 METHODOLOGY**

This project is built using integrated circuits (ICs) and discrete components. The stages are design separately. The design is composed of five (5) basic units which are: One-shot/ Monostable unit (Timing), BCD counter unit, Power Supply unit, Decoder unit and LED display unit. Hence the system is expected to:

- ❖ Provide a stable regulated dc power of five volts (5V) with sufficient current delivery to drive the various components.
- ❖ Generate a one-shot/ monostable pulse that will be timed through the 555-timer and the counting being done by the BCD counter.
- ❖ Provide circuitry for decoding such sequential pulses and appropriate display of such pulses.

#### 1.4 PROJECT LAYOUT.

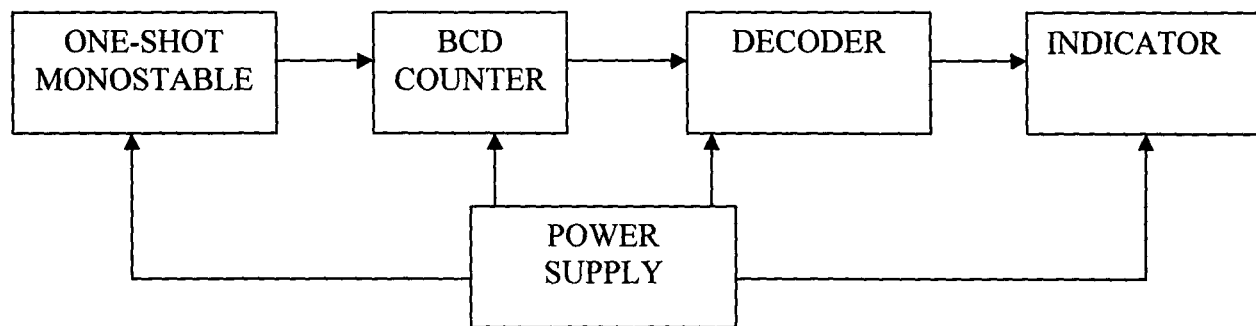

Fig 1.1: Layout of an Electronic Schedule Chart.

#### 1.5 SCOPE OF THE PROJECT.

The concept and motivation behind this project is to design and construct an Electronic Schedule Chart, which will inform/indicate the where about of the occupant in a residence.

The knowledge of a monostable multivibrator is used to achieve the display pattern of the project. With the combination of other component; knowing well their functions the project is actualized and brought to reality

#### 1.6 SOURCES OF MATERIALS AND CONSTRAINTS.

The sources of materials used for this project were from the websites, textbooks of various Authors, Lecture notes and ideas from Colleagues, which will all be stated /listed under references.

The constraint of this project came during the time of construction, which was never easy to put together. Having proper consultation with friends, the challenge on this project was finally overcome.

## CHAPTER TWO

### THEORETICAL BACKGROUND

#### 2.1 HISTORY OF ELECTRONICS

Electronics can be said to have started with the discovery of cathode rays in the 1890s. Cathode rays had been seen when an electric discharge took place between two electrodes in an evacuated glass tube (discharge tube). Sir Williams Crookes (1832-1919) had called them “Cathode rays” since they started at the negative electrode (cathode) and moves toward the positive electrode (Anode). They travel in straight lines and exert pressure on any object placed in their path.

Sir J.J. Thompson (1856-1940) suggested that cathode rays were actually a stream of fast moving electrons from the cathode to the anode. In 1897 he succeeded in measuring the charge – to – mass ratio ( $c/m$ ) of the electron, which was found to be  $1.756 \times 10^{11}$  c/kg. In 1909, A.A. Millikan (1868-1953), in a series of very delicate experiments succeeded in measuring the charge of the electron as,  $e = -1.60 \times 10^{-16}$  c. The electronic mass was found to be equal to  $m = 9.11 \times 10^{-31}$  kg.

Electronics is over hundred years old now. Before 1900, there were no radios, televisions, calculators, computers or artificial satellites. There was no telecommunication, consumer electronics, medical electronics, robotics, avionics, informatics or such other services, which we now take for granted. The future of electronics may well be imagined as man reach for the planets and the world becomes a global village. [4]

## 2.1.1 BRANCHES OF ELECTRONICS

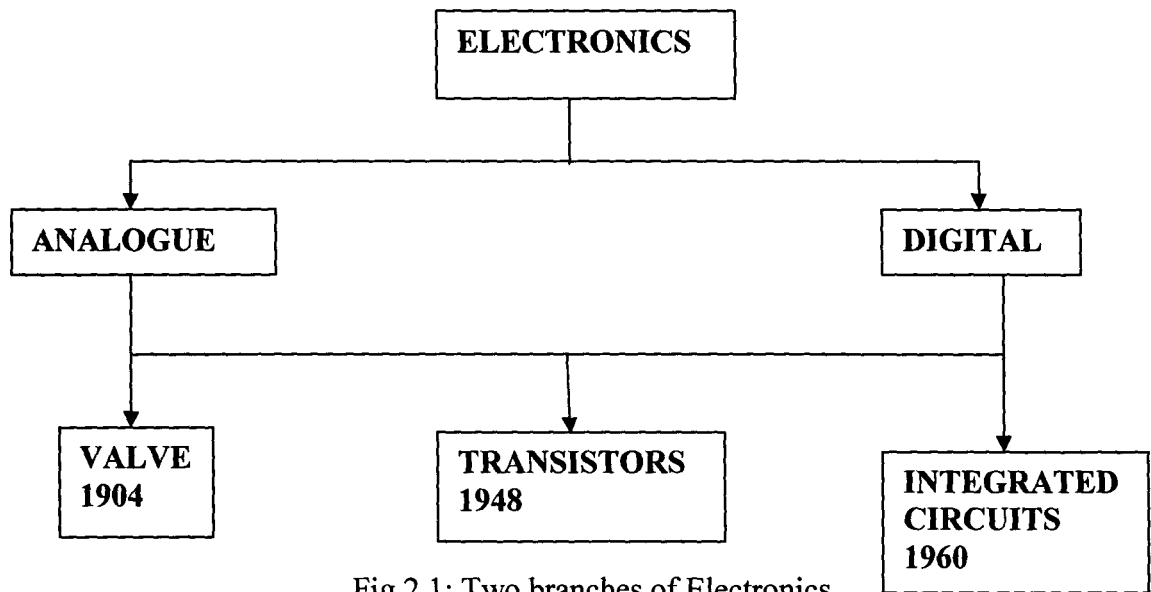

Fig 2.1: Two branches of Electronics

The Fig 2.1 above shows that Electronics is divided into two branches which are Analogue and Digital.

## 2.2 LITERATURE REVIEW

The manual schedule chart has been the most commonly used door notice found in our residences. It has been designed without any technological experience because of its simplicity. The construction takes the form of a pie - chart with all the data inserted inside it. Whenever a data is to be displayed, it will be removed from it source and attached at the door for visitor (s) to see. The disadvantage of the manual schedule chart is that anybody can change the displayed data on the door without the occupant being aware thereby giving wrong information to the visitor (s).

Electronic Schedule chart, name given to this project is designed from the concept of the importance of electronics, which was discovered by scientist in order to make life easy.

Man believes in the simplicity of life that is why technology will keep changing and the best of electronics will be utilized.

This project has been designed in such a way that, any information displayed will never be changed by anybody unless the occupant decides to change or instruct the person to change it thereby having advantage and improvement over the earlier mentioned above. Anytime the switch is triggered, it displays information for the visitor(s) to see thereby closing the communication gap.

Furthermore, with the help of this project visitor(s) are rest assured that whenever they pay an occupant a visit at his/her residence, they can tell his/her where about without wasting their precious time.

## **2.3 PRINCIPLE OF OPERATION**

When the switch of the 9V battery is closed, the LM7805 regulates it to 5V, which is supplied to the system for operation. The SET switch when triggered, generate a pulse, which is timed by the 555-timer; the generated pulse is in one-shot/ monostable state. The pulse is counted by BCD counter and the output is decoded through the Decoder. The Decoder selects the required output and display the specific LED by emitting light.

## **2.4 THEORY OF THE PROJECT**

### **2.4.1 MONOSTABLE MULTIVIBRATORS**

The monostable multivibrator or “one-shot” (emphasis on the word “one”), is a variation of the flip-flop (which is sometimes called a bistable multivibrator) in which the output of one of the gates is capacitively coupled to the input of the other gate. The result is that the circuit sits in one state. If it is forced to the other state by a momentary input pulse, it



will return to the original state after a delay time determined by the capacitor value and the circuit parameters (input current, etc). It is very useful for generating pulses of selectable width and polarity. Making one-shots with gates and RCs is tricky, and it depends on the details of the gates input circuit, since for instance, you wind up with voltage swings beyond the supply voltages. Rather than encourage bad habits by illustrating such circuits, one-shot will be treated as an available functional unit. In actual circuit it is best to use a packaged one-shot; you construct your own only if absolutely necessary, e.g. if you have a gate available and no room for an additional IC package (even then may be you shouldn't). [1]

## **2.4.2. ONE-SHOT CHARACTERISTICS**

### **2.4.2.1 INPUTS**

One-shots are triggered by a rising or falling edge at the appropriate inputs. The only requirement in the triggering signal is that it has some minimum width, typically 25ns to 100ns. It can be shorter or longer than the output pulse. In general, several inputs are provided so that several signals can trigger the one-shot, some on positive edges and some on negative edges (remember, a negative edge means a HIGH – to – LOW transition, not a negative polarity). The extra inputs can also be used to inhibit triggering. [1]

### **2.4.2.2 RETRIGGERABILITY.**

Most monostables e.g. the 4538, '123 and '423, will begin a new timing cycle if the input triggers again during the duration of the output pulse. They are known as retriggerable monostable. The output pulse will be longer than usual if they are retriggered during the pulse, finally terminating one pulse width after the last trigger. The '121 and '221 are non-retriggerable; they ignore input transitions during the output pulse. Most retriggerable one-shots can be connected as non-retriggerable one-shots. [1]

### 2.4.2.3 RESETTABILITY

Most monostables have a jam RESET input that overrides all other functions. A momentary input to the RESET terminal terminates the output pulse. The RESET input can be used to prevent a pulse during power – up of the logic system. [1]

### 2.4.2.4 PULSE WIDTH

Pulse widths from 40ns up to milliseconds (or even seconds) are attainable with standard monostables, set by an external capacitor and (usually) resistor combination. A device like 555 can be used to generate longer pulses, but its input properties are sometimes inconvenient. [1]

## 2.4.3 COUNTERS

Flip-flops can be connected to function as electronic counters to count random events or to divide a frequency or to measure a parameter such as time, distance or speed. Counters are used to keep track of operations in digital computers and in instrumentation. The JK master-slave flip-flop is widely used in counter design, but T & D flip-flop are also useful.

**DECADE COUNTER:** - Counters that communicate with humans usually display results in decimal system. However, flip-flop count in binary; therefore, binary numbers must be coded in decimal. The most common code for obtaining a binary-coded-decimal (BCD) is the 8421 code, which indicates how the four binary digits are weighted.

To count to 10, four flip-flops are required. The usual way to get 10 distinct states is to modify a 4 - bit binary counter so that it skips the last 6 states. It counts normally from 0 to 9, and then feedback logic is provided so that at the next count the decimal sequence is reset to zero. It is called BCD counter because it uses only the 10 BCD code groups 0000, 0001, -----,

1000 and 1001. Any decade counter that counts in binary from 0000 to 1001 is a BCD counter.

Decade counters, especially the BCD type are widely used in applications where pulses or events are to be counted and the results displayed on some type of decimal numerical readout. [1]

#### 2.4.4 DECODERS

Decoder is simply defined as a combinational circuit, which generates at its output all of the  $2^n$  canonical product terms of the  $n$  signals connected to its input. As the canonical product terms are mutually exclusive and the logical sum of all of the  $2^n$  terms is equal to Boolean 1, one and only one output of a decoder is 'selected' for any combination of input signals. If the decoder is implemented as a set of  $2^n$  AND-gates each with  $n$  inputs, the selected output will go HIGH while all others remain LOW. However, if it is implemented as a set of  $2^n$  NAND-gates each with  $n$  inputs, the selected output will go LOW while all others remain HIGH. [5]

A general block diagram of a decoder is shown in fig 2.2:

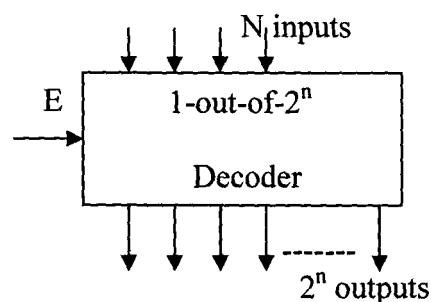

Fig 2.2: General block diagram of a N-line -to -2<sup>n</sup> - line decoder.

The gates of a decoder are often provided with another input, which is common on all gates & brought to the decoder input. This is the enable (E) input, which allows decoders to be

used in 'tree-structured' arrangements. When the decoder is disabled ( $E=0$ ), all the outputs are set to zero, when enabled ( $E=1$ ), one specific output line is set to 1.

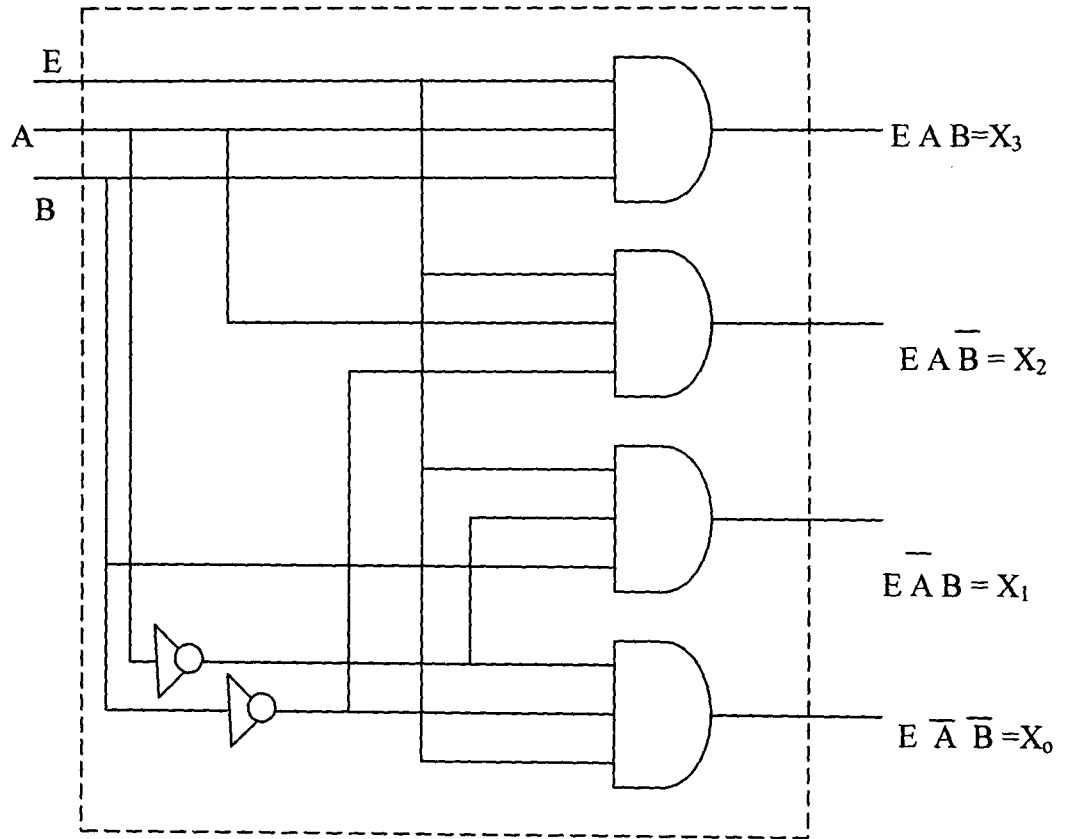

Fig 2.3(i): Circuit diagram of an SSI implementation of a 1-of-4 decoder.

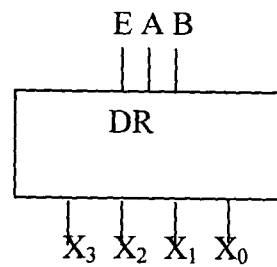

Fig 2.3(ii): Symbol used for an SSI implementation of a 1-of-4 decoder.

Table 2.1: Truth table of a 1 – of – 4 decoder

E	A	B	X <sub>0</sub>	X <sub>1</sub>	X <sub>2</sub>	X <sub>3</sub>
0	X	X	0	0	0	0
1	0	0	1	0	0	0
1	0	1	0	1	0	0
1	1	0	0	0	1	0
1	1	1	0	0	0	1

The Fig 2.3(i) shows four 2 – input AND - gate used as a 2- line to 1 –of – 4 decoder or simply a 1 – of – 4 decoder. There are two inputs to the circuit, labeled A and B. With two inputs, there are four possible input combinations. Notice that the circuit is arranged so that each AND gate will respond with a high output to a different input combination.

#### 2.4.5 LIGHT – EMITTING DIODE.

In Fig 2.4 below, a source connected to a resistor and LED. The outward arrows symbolize the radiated light. In a forward – biased LED, free electrons cross the junction and fall into holes. As these electrons fall from a higher to a lower energy level, they radiate energy. In ordinary diodes, this energy is radiated in the form of heat. But in an LED, the energy is radiated as light. LED has replaced incandescent lamps in many applications because of low voltage, long life and fast on – off switching.

By using elements like gallium, arsenic and phosphorous, a manufacture can produce LED that radiate red, green, yellow, blue, orange or infrared (invisible).LEDs that produce visible radiation are useful with instruments, calculators and so on. The infrared LED finds applications in burglar alarm systems CD players and other devices requiring invisible radiation. [2]

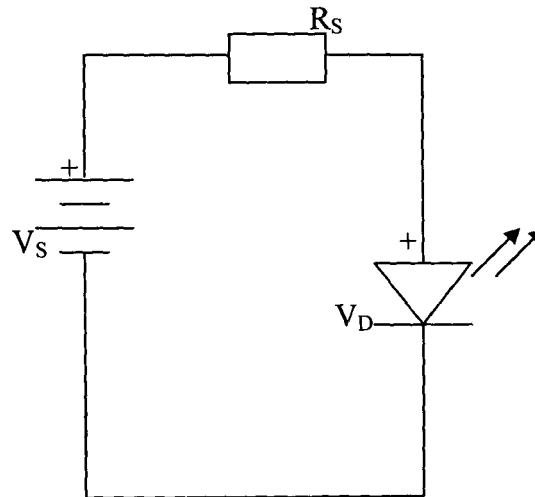

Fig 2.4: Basic circuit of a LED indicator

#### 2.4.5.1 LED VOLTAGE AND CURRENT

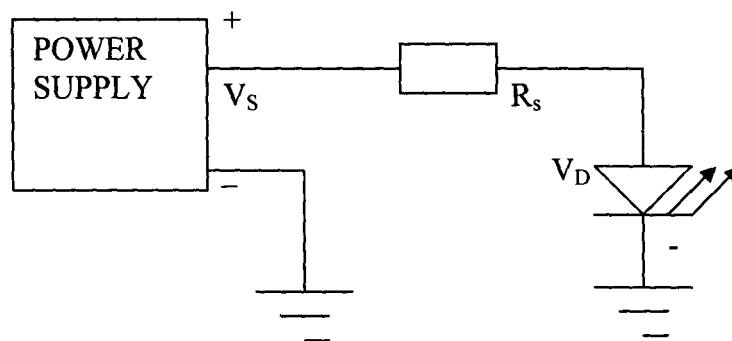

Fig 2.5: Practical circuit of a LED indicator.

The resistor here is the usual current limiting resistor that prevents the current from exceeding the maximum current rating of the diode. Since the resistor has a node voltage of  $V_S$  on the left and a node voltage of  $V_D$  on the right, the voltage across the resistor is the difference between the two voltages. With ohm's law, the series current is:

$$I_s = \frac{V_S - V_D}{R_s} \quad (2.1)$$

For most commercially available LEDs, the typical voltage drop is from 1.5v to 2.5v for currents between 10mA and 50mA. The exact voltage drop depends on the LED current, colour, tolerance and so on.

#### 2.4.5.2 LED BRIGHTNESS

The brightness of an LED depends on the current. When  $V_S$  is much greater than  $V_D$ , the brightness of the LED is approximately constant. For instance, a TIL 222 is a green LED with a forward voltage of between 1.8(minimum) and 3v (maximum), for a current of 25mA. If a circuit like Fig 2.5 above is mass-produced using a TIL 222, the brightness of the LED will be almost constant if  $V_S$  is much greater than  $V_D$ . If  $V_S$  is only slightly more than  $V_D$ , the LED brightness will vary noticeably from one circuit to the next.

The best way to control the brightness is by driving the LED with a current source. This way the brightness is constant because the current is constant. [2]

#### 2. 4. 5. 3. BREAKDOWN VOLTAGE

LEDs have very low breakdown voltages, typically 3V and 5V. Because of this, they are easily destroyed if reversed-biased with too much voltage. When troubleshooting an LED circuit in which the LED will not light, check the polarity of the LED connection to make sure that it is forward-biased. [2]

## CHAPTER THREE

### DESIGN AND CONTRUCTION

This project was designed using a one shot monostable, a binary counter, a 1-of-16 decoder and a series of LED indicator.

The project is divided into five basic units. These are the power supply unit, the one-shot monostable unit, the binary counter unit, the decoder unit and the LED indicator unit. The block diagram is shown in Fig 3.1 below.

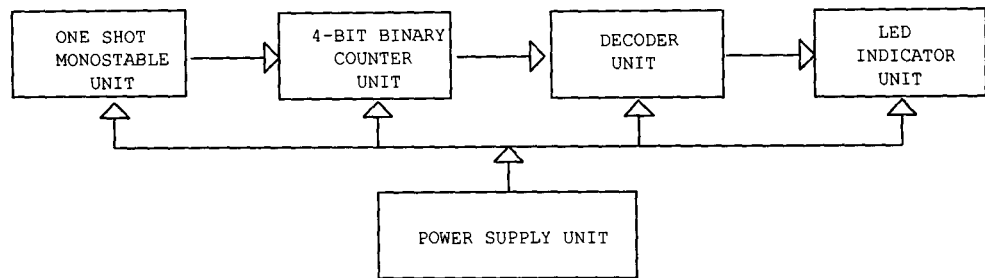

Fig 3.1: Block diagram of the project

#### 3.1 POWER SUPPLY UNIT

This unit supplies the entire system the required power. It consists of a 9V battery, a voltage regulator and a capacitor. The circuitry of the power supply unit is given in Fig 3.2.

##### 3.1.1 THE IC VOLTAGE REGULATOR

The Voltage regulator comprises a class of widely used ICs. Regulator IC units contains the circuitry for reference source, comparators, control devices and overload protection all in a single IC. Although the internal construction of the IC is somewhat different from that of the discrete components circuits, the external operation is much the same. A voltage regulator is an electrical regulator designed to automatically maintain a constant voltage level. It may use an electromechanical mechanism, or passive or active electronic



components. Depending on the design, it may be used to regulate one or more AC or DC voltages.

With the exception of shunt regulators, all modern electronic voltage regulators operate by comparing the actual output voltage to some internal fixed reference voltage. Any difference is amplified and used to control the regulation element. This forms a negative feedback servo control loop. If the output voltage is too low, the regulation element is commanded to produce a higher voltage. For some regulators if the output voltage is too high, the regulation element is commanded to produce a lower voltage; however, many just stop sourcing current and depend on the current draw of whatever it is driving to pull the voltage back down. In this way, the output voltage is held roughly constant. The control loop must be carefully designed to produce the desired trade-off between stability and speed of response. [10]

## **LM78XX/LM78XXA**

### **3-Terminal 1A Positive Voltage Regulator**

#### **Features**

- Output Current up to 1A
- Output Voltages of 5, 6, 8, 9, 10, 12, 15, 18, 24
- Thermal Overload Protection
- Short Circuit Protection
- Output Transistor Safe Operating Area Protection

## GENERAL DESCRIPTION

The LM78XX series of three terminal positive regulators are available in the TO-220 package and with several fixed output voltages, making them useful in a wide range of applications. Each type employs internal current limiting, thermal shut down and safe operating area protection, making it essentially indestructible. If adequate heat sinking is provided, they can deliver over 1A output current. Although designed primarily as fixed voltage regulators, these devices can be used with external components to obtain adjustable voltages and currents.

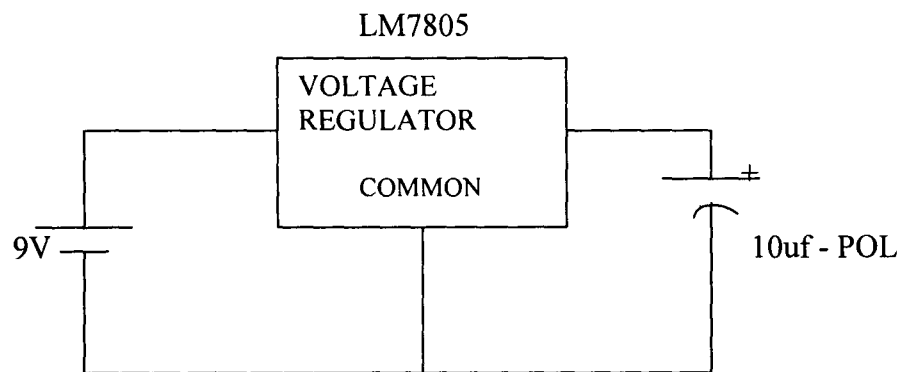

Fig 3.2: Circuit diagram of the power supply

From the circuitry in Fig 3.2, the LM7805 voltage regulator is used to regulate the voltage of the battery from 9v to 5v. This voltage level was chosen because of the digital Integrated Circuit (IC) used (the binary counter and the decoder). From their data sheet a 5V dc is suitable for powering them. [9]

A capacitor of 10uf 10v is used across the voltage regulator. According to the data sheet of the LM7805 voltage regulator, the 10uf 10v capacitor improves the transient respond. [10]

### 3.2 TIMING UNIT

The timer unit was accomplished with the aid of a 555 timer IC.

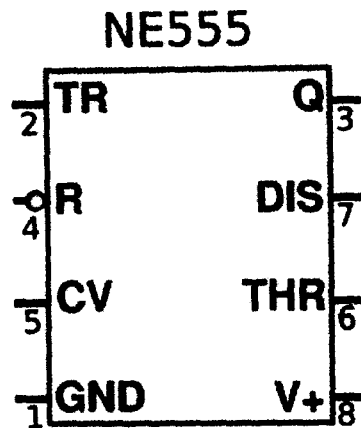

Fig. 3.3: Schematic symbol of the 555 timer

The 555 is an integrated circuit (chip) implementing a variety of timer and multivibrator applications. The IC was designed and invented by Hans R. Camenzind. It was designed in 1970 and introduced in 1971 by Signetics (later acquired by Philips). The original name was the SE555/NE555 and was called "The IC Time Machine". It is still in wide use, thanks to its ease of use, low price and good stability.

The 555 timer is one of the most popular and versatile integrated circuits ever produced. It includes 23 transistors, 2 diodes and 16 resistors on a silicon chip installed in an 8-pin mini dual-in-line package (DIP-8). The 556 is a 14-pin DIP that combines two 555s on a single chip. The 558 is a 16-pin DIP that combines four, slightly modified, 555s on a single chip (DIS & THR are connected internally; TR is falling edge sensitive instead of level sensitive).

Also available are ultra-low power versions of the 555 such as the 7555 and TLC555. The 7555 requires slightly different wiring using fewer external components and less power. The 555 has three operating modes:

- **Monostable mode:** in this mode, the 555 functions as a "one-shot". Applications include timers, missing pulse detection, bouncefree switches, touch switches, Frequency Divider, Capacitance Measurement, Pulse Width Modulation (PWM) etc
- **Astable - Free Running mode:** the 555 can operate as an oscillator. Uses include LED and lamp flashers, pulse generation, logic clocks, tone generation, security alarms, pulse position modulation, etc.
- **Bistable mode:** the 555 can operate as a flip-flop, if the DIS pin is not connected and no capacitor is used. Uses include bouncefree latched switches, etc. [10]

In this project, only the monostable mode was used.

### **3.2.1 ONE-SHOT MONOSTABLE UNIT**

This unit consists of two resistors R1 and R2, one capacitor C1, a push button and a 555 timer.

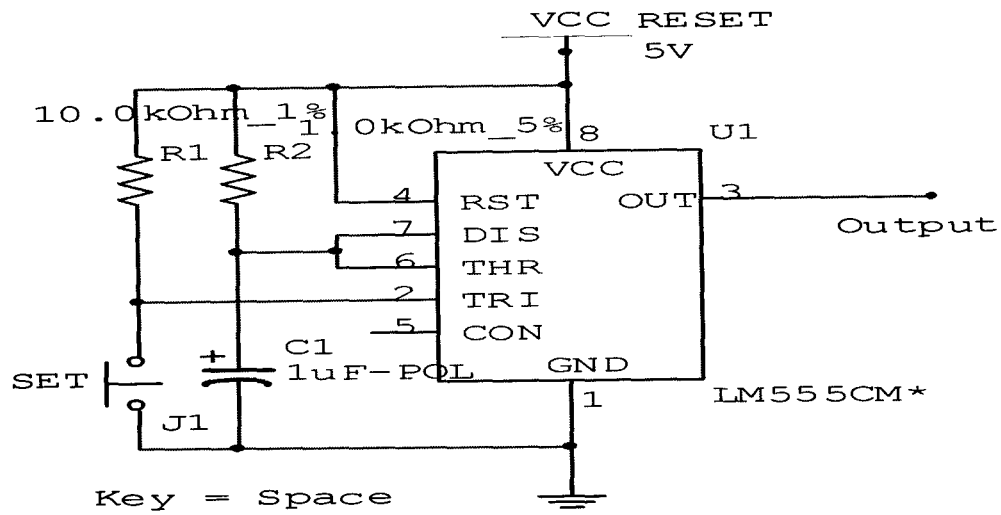

Fig 3.4: One-shot monostable circuit diagram

From the circuitry in Fig 3.4, the 555 timer is operating as a triggered one-shot monostable. The trigger input is initially HIGH because of the pull-up resistor R2. When a negative-going trigger pulse is applied to the trigger input, the threshold on the lower comparator in the 555 timer is exceeded. The capacitor C1 now begins to charge through the resistor R1. As soon as the charge on the capacitor equals  $2/3$  of the supply voltage, the upper comparator triggers and resets the control flip-flop. This terminates the output pulse which

switches back to zero. Whenever the push button is pressed, a negative trigger pulse is applied to Pin2; the 555 will generate its single-duration output pulse, depending upon the values of R1 and C1 used. The values of R1 and C1 were chosen from the expression below.

$$T = 1.1 \times R \times C \text{ (in seconds), where } R = 1\text{k}\Omega, \text{ and } C = 1\mu\text{f} \quad (3.1)$$

$$T = 1.1 \times 1000 \times 1 \times 10^{-6} = 1.1 \times 10^{-3}\text{s}$$

### 3.3 BINARY COUNTER UNIT

This unit makes use of a dual 4-bit internally synchronous binary counter (4520).

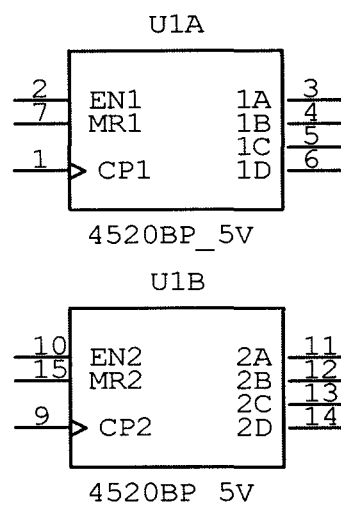

Fig 3.5: Pin out of the CD4520

From the diagram in Fig 3.5, the input pins are CP1, EN1, and MR1 while the output pins are 1A, 1B, 1C, and 1D. And the supply pins are GND and VCC. The CP1 pin is the clock input pin. This pin is connected to the output of the one shot monostable. The output of the binary counter increment when the IC is clocked, i.e. it counts from 0 to 15. The EN1 pin is the enable pin. This pin must be connected to VCC for the IC to be in the enable state. The MR1 is the reset pin. When this pin is connected to VCC, the output of the IC is reset to zero.

For this project, the reset pin is pull down i.e. connected to GND via a 4.7K ohms resistor. It should be observed that a normally open push button is connected across VCC and the reset pin. This connection enables the IC to be reset when desired.

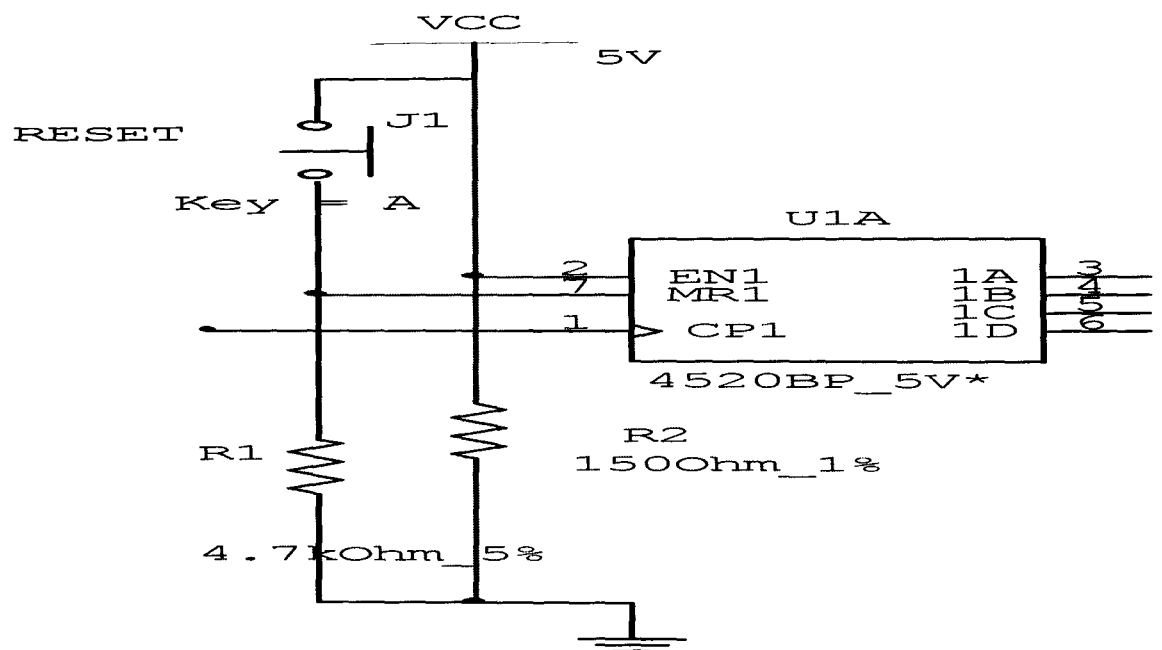

Fig 3.6: The Binary Counter configuration

### 3.4 DECODER UNIT

This unit is necessary to decode the output of the binary counter used.

A **decoder** is a device which does the reverse of an encoder, undoing the encoding so that the original information can be retrieved. The same method used to encode is usually just reversed in order to decode.

In digital electronics this would mean that a decoder is a multiple-input, multiple-output logic circuit that converts coded inputs into coded outputs, where the input and output codes are different. e.g.  $n$ -to- $2^n$ , BCD decoders. Enable inputs must be on for the decoder to function, otherwise its outputs assume a single "disabled" output code word. Decoding is necessary in applications such as data multiplexing, 7 segment display and memory address decoding.

The simplest decoder circuit would be an AND gate because the output of an AND gate is "High" (1) only when all its inputs are "High".

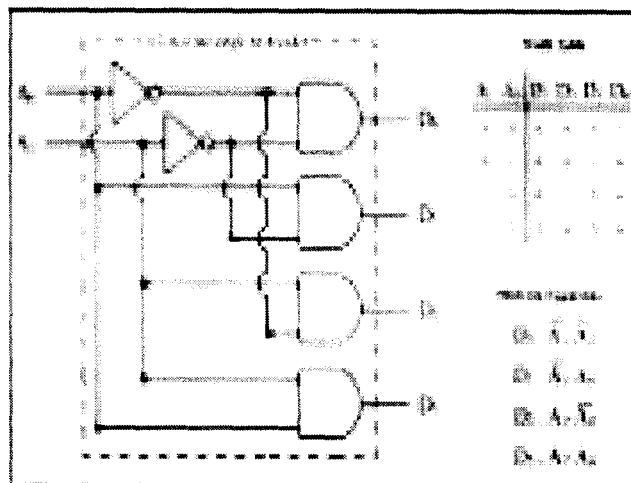

Fig 3.7: A 2-to-4 Line Single Bit Decoder



A slightly more complex decoder would be the  $n$ -to- $2^n$  type binary decoders. These type of decoders are combinational circuits that convert binary information from 'n' coded inputs to a maximum of  $2^n$  unique outputs. We say a *maximum* of  $2^n$  outputs because in case the 'n' bit coded information has unused bit combinations, the decoder may have less than  $2^n$  outputs. We can have 2-to-4 decoder, 3-to-8 decoder or 4-to-16 decoder. We can form a 3-to-8 decoder from two 2-to-4 decoders (with enable signals). [7]

In this project the decoder used is CD4514BP. The CD4515BP consists of a 1-of-16 decoder. The pin out of the CD4514 is given in Fig 3.8.

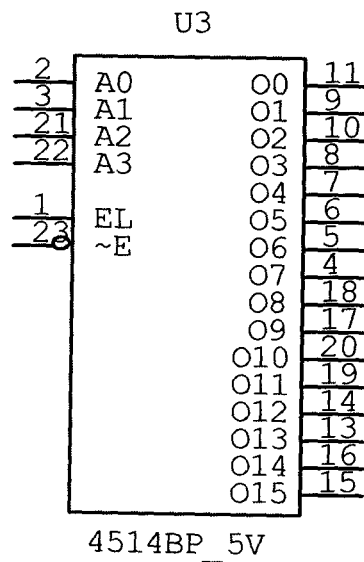

Fig 3.8: Pin out of CD4514

The input pins are A0, A1, A2, A3, EL and E. While the out put pins are from Q0-Q15. For the CD4514 to be in the enable state, Pin EL has to be connected to VCC, while Pin E is connected to GND.

### 3.5 INDICATOR UNIT

This unit is made up of 16 LEDs and 16 current limiting resistors. Each output pin is connected to a 150 ohm resistor. This is necessary to limit the current flowing into the LED. The current through each of the LED is calculated from the formula as shown below.

$$\text{Current } I = \text{Voltage (VCC)} / \text{Resistance (R)} \quad (3.2)$$

$$= 5 / 150$$

$$= 0.03 \text{ A}$$

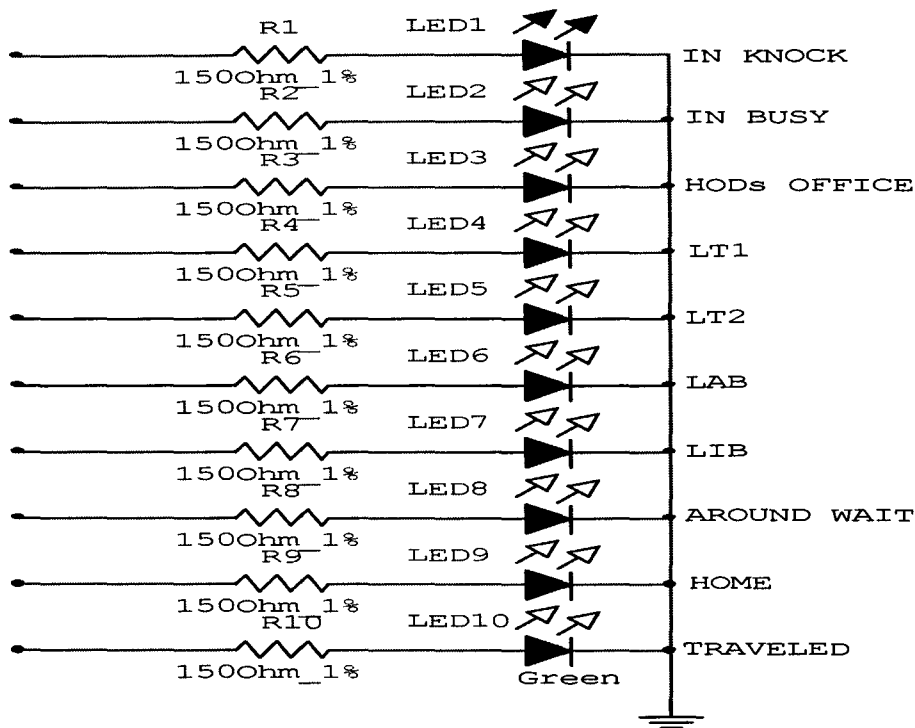

Fig 3.9: The interface between the Indicator LEDs and the Decoder

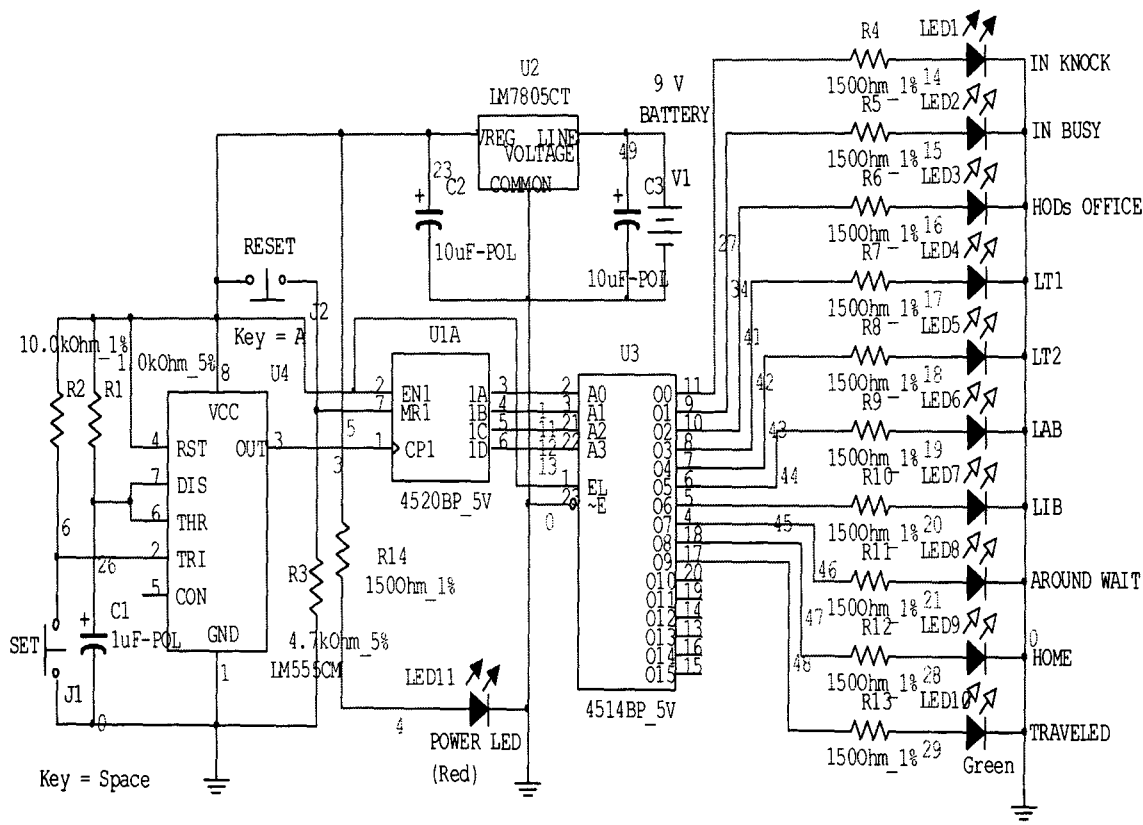

Fig 3.10: Complete circuit diagram of the Electronic Schedule Chart.

## CHAPTER FOUR

### TESTS, RESULTS & DISCUSSION.

This chapter summarizes the process that was taken in the implementation of the designed circuit for an Electronic Schedule Chart. The aim of testing is to determine:

- The level of functionality of the individual components
- The level of functionality of the various units
- The effect which a component or unit would have on the system when it fails
- Provide a sequential procedure for trouble-shooting the system.

The apparatus used for testing of the components includes the digital multi-meter, breadboard wire strippers/ cutter and the oscilloscope.

#### 4.1 TESTING OF COMPONENTS, UNITS & FINAL CIRCUIT

The testing of the project work was divided into three stages, the first being the testing of individual components, next is the testing of the various units and finally the testing on the Vero board.

**RESISTOR:** The values of the various resistors used were measured using the digital multimeter and then compared with the value read-off by using colour code.

**DIODE:** The diode used is light emitting diode and the voltage drop across them was found to be 0.6V.

**CAPACITOR:** A digital multimeter was used to measure the voltage rating of the capacitor, which approximately conforms to the manufacturer's value.

**DECODER:** Continuity test was carried out when placed on the breadboard.

**POWER SUPPLY:** When measured with a digital multimeter, the value was close to the manufacturer's value.

**COUNTER & 555 TIMER:** Continuity test was carried out on the BCD counter & NE555 timer.

The next stage of testing was carried out on the bread board .The various components were assembled as shown in the circuit diagrams into their various units on the bread board. As each unit is introduced, it is tested with power from the 9V battery to get an output.

The final stage of testing is carried out starting with the implementation on the Vero board. The various units was built on the Vero board and soldered onto it according to the circuit diagram. The following precautions were established:

- The legs of the components were trimmed.
- Ensure a clean soldering of the components on the vero board.
- Ensure continuity of the soldered parts.
- Prevent bridging of the connecting wires used in joining the various components together.

After carefully assembling the various units on the vero board, the project was tested and confirmed working based on the objective.

## **4.2 RESULTS**

The following results were obtained.

- Test conducted on components.
- Test conducted on each units.
- Test conducted on the complete circuit when the units were coupled together.

### **4.3 DISCUSSION OF RESULTS**

For the test conducted on the various components, the variation is due to the manufacturing process that was carried out on them.

The supply was regulated by the IC voltage regulator to drive the system with the required 5volts. The pulse generated was a one- shot that goes HIGH- to- LOW state, and the time was calculated to be 0.001secs. The output of the binary counter does its counting from 0 –15 while the decoder, decodes as usual the output from the counter. The display unit was achieved accurately by the LED with a current limiting resistor of 0.03A passing through it.

# **CHAPTER FIVE**

## **CONCLUSION AND RECOMMENDATION**

### **5.1 CONCLUSION**

It can be concluded from the designing and construction process, that the aim of incorporating project work into the university syllabus was achieved since we students were able to appreciate the fascinating aspect of our profession. This is because we were able to acquire some practical knowledge to compliment the theory we were taught in class. Practically, we know how the electronic components behave.

From the result, it shows that the aim and objective stated in chapter one were achieved, since the principle used for the system works as required. It could be noticed that, the completion of this project helps a visitor from being stranded whenever he/she visits an occupant thereby bridging the communication gap between both parties.

For further improvement on this project, the display unit can be achieved using liquid crystal display (LCD) instead of the light – emitting diode (LED) used. Although the LCD is not readily available in the market, effort could be made to demand for them since it would help in bringing out the beauty of this project.

### **5.2 RECOMMENDATION**

Some difficulties were encountered during the cause of this project work, which is as a result of government inconsistent policies that affect the university educational system. To ease these difficulties, I strongly recommend that:

1. The university should upgrade their laboratory, workshop tools and equipments so that students can know how to use them properly.
2. The university programme should be scheduled in such a way that there will be project work in the syllabus of every semester right from 300 level. Not ordinary laboratory practical.
3. There is need for government to fund our institutions adequately and also help students in actualising their dreams no matter how big it is.
4. Government and the university management should work as a team to build students that would aid the country's technological advancement.



## REFERENCES

1. Paul Horowitz Winfield Hill, the Art of Electronics, 2<sup>nd</sup> Edition, Pg 517 – 519.
2. Albert Paul Mavino, Malvino Electronic Principles, 6<sup>th</sup> Edition, Pg 165 – 166
3. R. S. Sedha, Digital Electronics, Pg 304 – 605
4. [www.musadaji.com/analogue-electronics/lecturenote](http://www.musadaji.com/analogue-electronics/lecturenote) 2005.
5. M.M.Mano & C.R.Kima, Logic & Computer Design fundamentals, International Edition, pg 39- 71.
6. [http:// en. wikipedia.org/wiki/chart](http://en.wikipedia.org/wiki/chart)
7. [http:// en.wikipedia.org/wiki/decoder](http://en.wikipedia.org/wiki/decoder)
8. [http:// en.wikipedia.org/wiki/555 timer IC](http://en.wikipedia.org/wiki/555_timer_IC)
9. [www.datasheetcatalog.com](http://www.datasheetcatalog.com)
10. [www.st.com/datasheet.lm78series.pdf](http://www.st.com/datasheet.lm78series.pdf)

## APPENDIX 1

### User's Guide

#### FEATURES

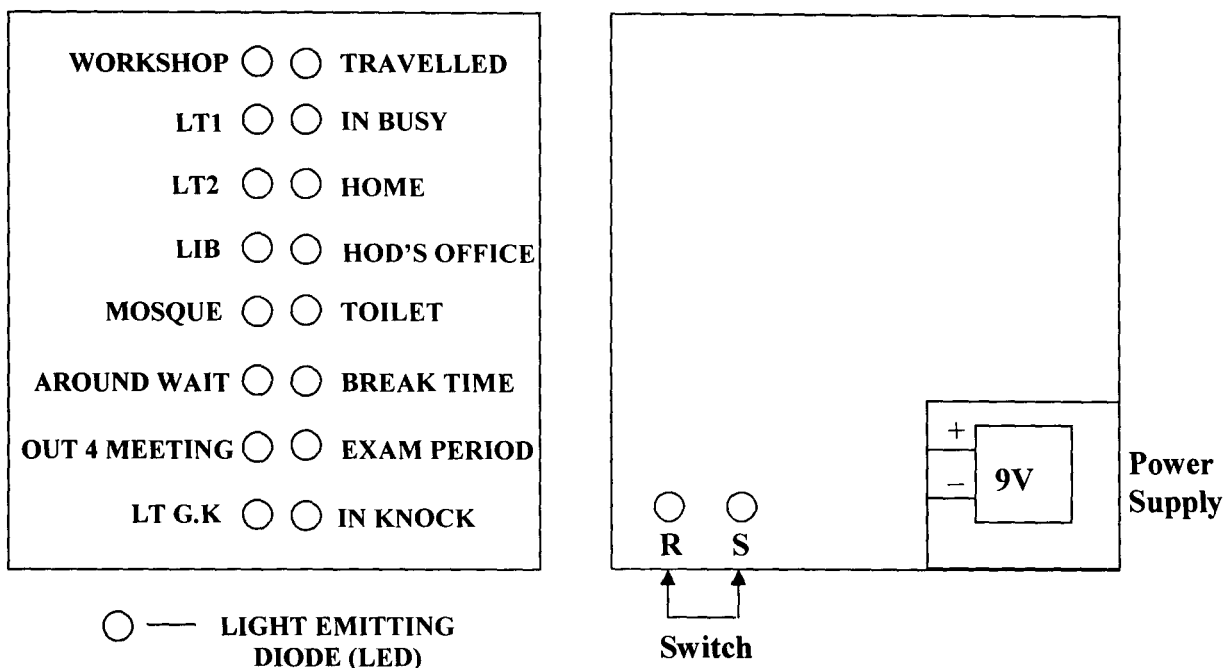

#### Operating Instructions.

- 1 Connect the terminals of the 9V power supply.
- 2 The Reset(R) and Set (S) switches are used to change the activities on the display.
- 3 The Reset(R) switch is used for the default display which is IN KNOCK, while the Set(S) switch can be used to achieve any of the display.
- 4 Any activity displayed will "ON" the LED. Whenever the LED displayed is not bright enough for the visitor to see, the 9V power supply should be changed.
- 5 Avoid unnecessary triggering of the switches when they are not in use.
- 6 Always ensure that, the display is placed on the door for visitors to see.
- 7 Always use dry cloth to clean the surface of the display to avoid dust.