

**DESIGN AND CONSTRUCTION OF
A TELEPHONE BUG FM
TRANSMITTER**

BY

**USIOBAIFO AUGUSTINE
2003/15493EE**

**A THESIS SUBMITTED TO THE DEPARTMENT OF
ELECTRICAL AND COMPUTER ENGINEERING
FEDERAL UNIVERSITY OF TECHNOLOGY, MINNA,
NIGER STATE**

**IN PARTIAL FULFILLMENT OF THE
REQUIREMENT FOR THE AWARD OF BACHELORS
OF ENGINEERING DEGREE (B.ENG) ELECTRICAL
AND COMPUTER ENGINEERING**

NOVEMBER, 2008

Dedication

This project work is dedicated first and foremost to the Almighty God who has been my source of strength and fountain of knowledge. And also to my parents in the persons of mr/mrs Joseph Usiobaifo who, single handedly have been very supportive and instrumental to my attaining this height... O God bless them with a ripe old age for me,

Attestation/Declaration page

I, USIOBAIFO AUGUSTINE, declare that this work was done by me and has never been presented elsewhere for the award of a degree. I also hereby relinquish the copy right to the Federal University of Technology, Minna

Usiobaifo Augustine

.....
(Name of Student)

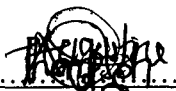
 12/11/2008
.....
(Signature and date)

Mr Henry Ohize

.....
(Name of Supervisor)

 7/11/08
.....
(Signature and date)

Engr.(Dr) Y .A Adediran

.....
(Name of HOD)

.....
(Signature and date)

.....
(Name of external examiner)

.....
(Signature and date)

Acknowledgement

I want to acknowledge God for the strength and power bestowed upon me since the inception of my under graduate studies to its completion.

To my parents Mr/Mrs. Joseph Usiobaifo words are woefully inadequate to express my heartfelt thanks for all God has done for me through you in building me in all dimension.

I will definitely not conclude on this acknowledgement without appreciating the contributions and supports of Revd Fr. Anthony Akande, Very Revd Fr. Samuel Sakaba, Rev. Sr .Theresiana, Mr/Mrs. De young Ajuluche, Dr /Mrs. Pius Salami and family and Rev Sr E amillian. among others

My thanks also goes to the HOD in person of Engr. (Dr) Y. A. Adediran for his honest advice. And to my supervisor Mr. Henry Ohize, for his untiring effort in ensuring that his students are doing well. I say may God bless you abundantly.

My thanks also goes to the Dr J.Tsado , Engr (Mrs) Caroline Alenoghena, Engr. Bala , Engr. Abolarinwa Joshua, and Engr (Dr) M.D abdullahi. You are all wonderful in your different ways. May God bless each and every one of you

And to others whose names are not mentioned here, God in His infinite goodness and mercies will reward each one of you for your various contributions to my studies

Finally, to the staff and management of NITEL,Minna, for their support. My thanks goes to Mall Audu Jibril A.(TM), Mr. M. Hassan(AM), Mr. Etuk and Mr. Mohammed Majji in your bid to ensure that my work was tested

Abstract

In the contemporary society, security has posed serious challenges to several individuals. There have been cases of people who call other people's lines to threaten them. Others have criminal intentions .how do we keep record of this communication is what this design affords us.

The design employs a 48volt dc to power the circuit with a transmitting range of 30 meter radius. It couples its power amplification into space with the aid of ferrite rod antenna. The transmission band falls in the range of 93 to 108MHz

With this design interfaced to a dedicated single telephone line, every call can be recorded and kept for security reasons through a dedicated FM band, security alertness can be created. This can be achieved where two security operatives establish communications with the intension of reaching the other parties at their post, provided that they keep their receivers on.

To realize such an aim therefore, the device connects in series to a telephone line's tip and ring. This couples both the audio signal and the power for the circuit from the channel.

Having done the interfacing, the first result obtainable is a sharp dialing tone and consequently the conversation

TABLE OF CONTENT pages

Cover page	i
Dedication	ii
Attestation/declaration	iii
Acknowledgement	iv
Abstract.....	v
Table of content	vi
List of figures	ix
List of tables	x
 Chapter One: Introduction	
1.0 General Introduction.....	1
1.1 Objectives of the project.....	2
1.2 The methodology.....	2
1.3 The scope of the project.....	4
 Chapter Two: Literature Review/ Theoretical Background	
2.1 History of telephone	5
2.1.1 History of telephone transmitter.....	5
2.2 History of wireless communication.....	7
2.3 Theoretical background of telephone and transmitter.....	8
2.3.1 Transmitter.....	9
2.4 Frequency modulation	9
2.4.1 Frequency spectrum of the FM wave.....	10
2.4.2 Mathematical representation of frequency modulation.....	10
2.5 Electromagnetic spectrum	12

Chapter Three: Design, construction and Implementation

3.1	Principle of operation.....	14
3.2	Definition of functional part list of the block diagram.....	15
3.3	Audio input	15
3.4	design of the oscillator and modulator stage.....	16
3.4.1	The modulator.....	21
3.5	RF modulator stage.	24
3.5.1	The power amplifier design specification.....	25
3.5.2	Power calculations.....	28
3.5.3	Power supply / LED Indicator.....	29
3.6	Antenna	30
3.7	Audio modulating voltage.....	31
3.8	Design implementation	32

Chapter Four: Test, result and Discussion

4.1	Main constructed circuit test.....	35
4.2	The power supply stage	36
4.2.1	The range of transmission.....	36
4.2.2	The quality of reception.....	36
4.3	Alignment stage and procedure.....	36
4.4	Procedure	37
4.5	Further discussion of result	37
4.6	Limitation.....	38
4.7	Trouble shooting.....	38

Chapter Five: Conclusion

5.1	Summary	39
-----	---------------	----

5.2	problems encountered.....	39
5.3	Areas of possible improvement.....	40
5.4	Recommendation.....	40
	References	42
	Appendices	44

LIST OF FIGURES

FIGURES	NAMES	PAGE
2.4	Angular representation for instantaneous amplitude of FM	10
3.1	Block diagram of an FM Telephone Bug Transmitter	14
3.2	Circuit diagram of audio coupling network.....	15
3.3	Circuit diagram for the Oscillator / Modulator stage.....	16
3.4	Tank circuit of the oscillator.....	18
3.5	Inductor winding.....	19
3.6	Circuit diagram of a common base oscillator.....	20
3.7	Schematic diagram of a common base configuration.....	21
3.8	Typical illustration of a modulator.....	22
3.9	Circuit diagram of an RF amplifier	24
3.10	LED Indicator	29
3.11	Audio voltage modulating diagram.....	31

LIST OF TABLES

Tables	Names	Page
2.5	Tables of application of FM Band.....	13
3.5.1	Table of the characteristics of C9014.....	26

CHAPTER ONE

1.0 Introduction

The Telephone bug FM Transmitter is a simple, yet Ingenious device that connects in series to a phone line, collects power from the phone line and consequently transmits both sides of a conversation over the telephone to an FM [frequency modulated] Radio tuned to between 93 and 105MHz.

The Telephone bug FM Transmitter as the name implies, is an embodiment of three different units which are coupled together to achieve a target aim and objective. Each of these units constituting the name, Telephone bug FM Transmitter, can be explained separately. The telephone is a devise which creates a medium for two or more people to interact .The medium of communication could be through wireless mobile phone or through cable lines .Whatever the medium is ,whether wireless or cable line, the principle of transmission of the audio message from the source of signal to the destination is the same.

This brings to mind how the message communicated from the source reaches its target destination. Consequently, the destination or the receiver is able to understand and interpret the transmitted signal. By analogy, when the message usually the audio, leaves the source, it passes through an input transducer which eventually constitute an input signal to the communication channel. The communication channel finally communicates the signal to the output transducer from where it gets to its destination.

Signals that are being transmitted have different ways by which they can be modulated. The commonest type employed is the frequency modulation technique. This modulation types require that the carrier signal list modulated or varied in

accordance to the frequency of the modulating signal which is the audio message that is to be transmitted.

Recalling the fact that the transmitter is coupled to the telephone, the former processes the information or the message to be transmitted. Two processes are usually employed namely; modulation which has been described above and of course, coding.

Since it is intended for us to transmit the audio message or the conversation over a telephone line, bearing in mind that the transmitter connects in series to an existing telephone line, to seize power, the transmitter usually employs several techniques for its 'wiretap'. There are actually three different types of wiretaps which include, the slave parallel wiretap, the inductive wiretap and the RF transmitter wiretap.

The RF transmitter wiretap is the most popularly adopted method. The radio frequency transmitter wiretap technique involves attaching a small RF transmitter to the telephone line, or within the telephone instrument. The audio fluctuations from the telephone line conversation modulate the transmitter carrier, transmitting the conversation into free air space.

A series RF tap or leach is powered by the telephone line and therefore does not require frequent replacement of battery which enables indefinite operation. A popular RF series wiretap known as a drop-in can be installed in seconds. This device is built onto the back of a carbon microphone, which is typically found in most telephone handsets and replaces the standard receiver with this modified version.

RF transmitter taps offer several advantages over the other types of wiretaps. Because the listening post is a receiver requiring no wire lines run to it. The listening post can be located anywhere within the transmission range.

Secondly, the telephone bug FM transmitter is sound transmission unit for transmitting sound generated from the telephone onto an FM radio. It is a unit separated from the telephone which includes an FM frequency generating circuit for modulating a sound signal to a general FM radio through an antenna [line attached to the phone]. This unit ,comprise a frequency selection unit for selecting a frequency for the FM frequency generating circuit according to a frequency set on a user setting screen of the telephone.

The FM transmitter interfaces with the telephone or through a connector in other to receive its power supply from the telephone.

1.1 Objective of the Project

This design finds application in the area of security as stated below

1. It may be required for the intelligence department of the security services or security operatives to keep a recorded back up information of every communication. This devise is handy to provide such back up services whenever conversation is aimed at carrying out investigatory plans
2. This can also be used to provide security alertness to various security posts whenever the security of a place is threatened, provided every security post of a security network has her radio tuned to the required FM band.
3. In an industrial layout, where the control room is far away from the men at work, it may be required to disseminate certain instructions that need to be executed; this devise can provide the services of reaching them without stress

1.2 Methodology

The circuit connects in series with either the tip or the ring of a telephone line. Power for the circuit is full wave bridge rectified from the phone line by the diode of

the FM transmitter circuit. Coupled with the afore-mentioned, is a system of connections of capacitor and inductors to form an FM oscillator that operates at a frequency of around 93MHz. Owing to the clarity of signals, variable capacitors are used to adjust the FM band between specified ranges. In other words, they allow the frequency of the oscillator to select.

The audio signals generated from the phone line, is coupled for modulation with the oscillator's frequency. After this process has been accomplished, the modulated signal is ready to be transmitted through a radio frequency shunt that decouples dc power and the audio from the amplifier circuit of the FM transmitter.

1.3 The Scope of the Project Work

The project design of the telephone transmitter is targeted for a 30 meter range. By antenna attachment, the range can be increased. The antenna length used is 38.5cm of ferrite rod antenna which should be attached to the power amplifier circuit.

The transmission of the signal is through the frequency modulation band. The frequency range of transmission, within the scope of the project is within the frequency range of 93MHz and 108MHz. This range extension invariably depends on the choice of the capacitor which forms part of the FM oscillator circuit.

The voltage available for the telephone bug FM transmitter is a dc voltage taken from the phone line which ranges between 39-48 volts.

CHAPTER TWO

2.0 Literature Review/Theoretical Background

2.1 History of Telephone

As introduction, Telephone is a telecommunication device which is used to transmit and receive sound most commonly voice and speech across distance. Most telephone operate through transmission of electric signals over a complex telephone network which allow almost any phone user to communicate with almost any other. [1]

Historically therefore, the invention of telephone began in 1849 by Antonio meucci, an Italian living in Havand. He demonstrated a device he later called a telephone which involves direct connection to people. [2]

It is important to state that the invention and of course the identity of the inventor of the electric telephone remains in dispute. Antonio meucci, Johann Philipp Reis, Alexander Graham Bell and Elisha Gray among others have been credited with the invention. [2]

In 1854, meucci further demonstrated an electric telephone in New York. Shortly within six years, Jogann Philipp Reis demonstrated a telephone using a pressure contact transmitter after the make-break design of Bourseul and a knitting needle receiver. Witnesses said they heard human voices being transmitted. [2]

2.1.1 History of Telephone Transmitter

When Edison began working on the telephone in 1876, he focused on the weak point in Alexanda Graham Bell's System – the transmitter. In Bell Transmitter, sound waves vibrated a permanent magnet that in turn set up an induced current in the instrument is electromagnet. Instead of telegraph's make-and-break signal, the

telephone used a continuous variable current (termed undulatory) which, when transmitted through the line, could be turned back into sound waves by the receiver. However, the weak current set up by bell's transmitter limited the distance over which it could be used. Edison decided to employ a battery current on the line and used the sound waves to vary the current's strength by varying the resistance of the current-using carbon. [1]

By the end of 1877, Edison had devised a transmitter in which a small button of lampblack carbon was placed beneath the diaphragm of the transmitter. As sound waves moved the diaphragm, the pressure on the diaphragm button changed, thus varying the resistance of the current. In 1885, Edison developed an improved carbon transmitter for the Bell Telephone Company that used granules of roasted anthracite coal rather than lampblack. [1]

The first transatlantic telegraph cable was successfully completed on 27th of July, 1866, allowing transatlantic telecommunication for the first time. The first commercial telephone services were set up in 1878 and 1879 on both sides of the Atlantic in London and New Haven [1] [3]

Reis in 1861, managed to transfer voice electrically over a distance of 340 feet's. [1]

Elisha Gray in 1872, found Western Electric Manufacturing Company and eventually evented an electromagnetic device for transmitting musical tones and some of his receivers used steel diaphragms in 1874. [1]

On December 29, 1874 through February 11, 1876 demonstrated his musical tone device and transmitted familiar melodies through telegraph wire at the pre-sbyterians church in Highland park, Illinois and invented eventually too a liquid transmitter for use with a telephone but did not build one. [1]

On June 1875, Alexander Graham Bell transmitted the sound of plugged plucked steel reeds using electromagnet instrument. And on July 1875, used a bi-directional telephone that was able to transmit indistinct but voice like sound but not clear speech. Both the transmitter and the receiver were identical membrane electromagnet instruments. [1]

Finally, on March 10, 1876, Bell transmitted speech "Mr. Watson, come here, I want you" using a liquid transmitter and an electromagnetic receiver. [1]

The later history of additional inventions and improvements of the electrical telephone includes the carbon microphone later replaced by the electric microphone now used in almost all telephone transmitters [1]

2.2 History of Wireless Communication

In 1897, a French physicist Edouard Branly, coined the word 'radio' in the sense of wireless transmission. The word appeared in a 1907 article by Lee de Forest and was adopted by the United States Navy in 1912 and finally became common by the first commercial broadcast in the United States in the 1920s [4]

In 1878, David E. Hughes was the first to transmit and receive radio waves when he noticed that his induction balance caused noise in the receiver of his home made telephone. James Clerk Maxwell first described the theoretical basis of the propagation of electromagnetic waves in 1873. It was Heinrich Hertz who, between 1886 and 1888 first validated Maxwell's theory through experiment demonstrating that radio radiation had all the properties of waves (now called Hertzian waves). [5]

To state the obvious, wireless communication as an invention, lend credence to Maxwell and Hertz who laid the basis for our understanding of the transmission of electromagnetic waves. It was not long after their groundbreaking work that

demonstrated the transmission of information via these waves – in essence, the first wireless communication system. [6]

In 1898, Marconi made his well-publicized demonstration of wireless communication from a boat to the Isle of Wight in the English Channel. It is noteworthy that while Tesla was the first to succeed in this important endeavour, Marconi had the better public relations and is widely cited as the inventor of wireless communication receiving a nobel prize in 1909. [6]

2.3 Theoretical Background of Telephone And Transmitters

Elementary telephone system would consist of three elements:

- The equipment located at each subscriber which converts sound to electrical signals and back, and which allows the subscriber to answer or initiate a call.
- A central switching facility which interconnects all the subscribers.
- Wiring or other means to connect the subscriber to the central switching facility.

There are three principal ways subscriber may be connected to the Network of telephone.

- ❖ Historically, and still very commonly, by dedicated physical wire connections run in overhead or underground cables.
- ❖ By radio, as in cordless, cellular, satellite or radio telephone and [1]
- ❖ By voice over internet protocol (VOIP) telephone which use broadband internet connections.

2.3.1 Transmitter

Unless the message arriving from the information source is electrical in nature, it will be unsuitable for immediate transmission. It is necessary to convert the incoming sound signals into electrical variations, to restrict the range of the audio frequencies and them to compress their amplitude range. [7]

All this is done before any modulation. In wire telephony no processing may be required; but in long-distance communications, a transmitter is required to process, and possibly encodes, the incoming information so as to make it suitable for transmission and subsequent reception. [7]

Eventually, in a transmitter, the information modulates the carrier. Hence, the actual method of modulation varies from one system to another. Modulation may be high-level or low-level, and the system itself may be amplitude modulation, frequency modulation, pulse modulation, or any variation or combination of these depending on their requirements. [7]

2.4 Frequency Modulation

Frequency modulation is a system in which the amplitude of the modulated carrier is kept constant, while its frequency and rate of change are varied by the modulation signal. [7]

The first practical system was put forward in 1936, as an alternative to AM in an effort to make radio transmissions more resistant to noise. [7]

It is noteworthy to realize that the deviation of the carrier is proportional to the amplitude of the modulating voltage. The shift in the carrier frequency from its resting point compared to the amplitude of the modulating voltage called the deviation ratio (a deviation ratio of 5 is the maximum allowed in commercial broadcast FM). [7]

2.4.1 Frequency Spectrum of the FM Wave

On the frequency spectrum FM Band is located on a very high frequency (V.H.F) spectrum ranging from 30-300MHz. [7] [8]

The theoretical bandwidth required in FM is infinite. In practice, the bandwidth used is one that has been calculated to allow for all significant amplitudes of sideband components under the most exacting conditions. [7]

2.4.2 Mathematical Representation of Frequency Modulation (FM)

It can be deduced from the theoretical definition of an FM that the instantaneous frequency of the frequency modulated wave is given by:

$$f = fc(1 + KV_m \cos W_m t) \text{-----(1)}$$

Where:

fc = Unmodulated Carrier Frequency

k = Proportionality Constant

$V_m \cos W_m t$ = Instantaneous Modulating Voltage

The instantaneous frequency will be

$$f = fc[1 \pm KV_m] \text{--- (1) When the cosine term has its maximum value as } \pm$$

1 for a maximum deviation. Hence, the maximum deviation ∇f will be give by:

$$\Delta f = KV_m fc \text{----- (3)}$$

Considering the figure below,

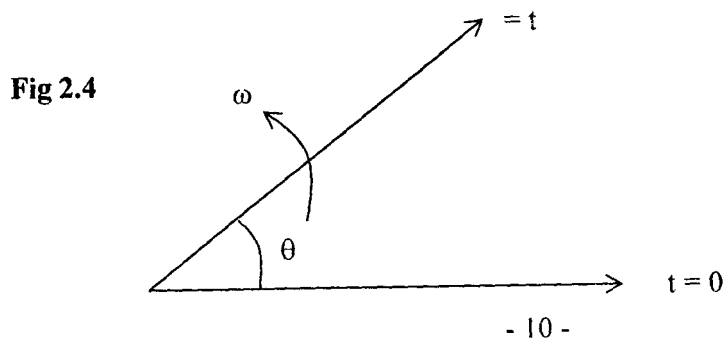

The instantaneous amplitude of the FM signal will be given by a formula of the form: $V = A \sin[f(\omega_c, \omega_m)] = A \sin \phi$ ----- (4)

Where $F(\omega_c, \omega_m)$ is some function of the carrier and modulating signal frequencies.

This function represents an angle and will be called θ for convenience.

From figure above, θ is the angle traced out by the vector A in time t. if A were rotating with a constant angular velocity, for example, ρ , this angle θ would be given by ρt (in radians). In this instance the angular velocity is anything but constant.

It is governed by the formula for W obtained from equation 1

That is, $w = \omega_c [1 + KV_m \cos \omega_m t]$

To find θ , w must be integrated with respect to time

$$\begin{aligned} \theta &= \int w dt = \int \omega_c [1 + KV_m \cos \omega_m t] dt \\ &= \omega_c \int [1 + KV_m \cos \omega_m t] dt \\ &= \omega_c \left[t + \frac{KV_m \sin \omega_m t}{\omega_m} \right] \\ &= \omega_c t + \frac{KV_m \sin \omega_m t}{\omega_m} \omega_c \\ &= \omega_c t + \frac{KV_m f_c \sin \omega_m t}{f_m} \quad \text{where } \omega_c = 2\pi f_c \text{ \& } \omega_m = 2\pi f_m \\ &= \omega_c t + \frac{\Delta f}{f_m} \sin \omega_m t \text{ -----(5)} \end{aligned}$$

The modulation index for Fm $^m f(\beta)$ is defined as:

$$^m f = \frac{\text{Maximum Frequency Deviation}}{\text{Modulating Frequency}} = \frac{\Delta f}{F_m}$$

And $\Delta F = KV_m f_c$

Substituting equation (5) into Equation (4) gives:

$$V = A \sin \left(\omega_{ct} + \frac{\Delta f}{Fm} \sin W_m t \right) \quad (6) \quad (7)$$

When modulation index M_f , is expressed as a percentage, the modulation index M_f is known as the depth of modulation [8]

2.5 Electromagnetic Spectrum

The electromagnetic (EM) spectrum is the range of all possible electromagnetic radiation. Also the electromagnetic spectrum ' (usually just spectrum) often object is the frequency range of electromagnetic radiation with wavelengths from thousands of kilometers down to fractions of the size of an atom [9]

Electromagnetic energy at a particular wavelength λ (in vacuum) has an associated frequency 'f' and photon energy E: Thus the electromagnetic spectrum may be expressed equally well in terms of these quantities, related according to the equation below. [10]

$$\text{Wave speed } (c) = \text{Frequency } (f) \times \text{Wavelength } (\lambda)$$

The table below shows three out of the eleven ranges and classifications of the electromagnetic spectrum.

Band Name	ITU Band	Frequency & Wavelength	Application
Medium Frequency (MF)	6	300-3000kHz 1km-100m	Navigation, time signal AM long wave broadcasting
High Frequency (HF)	7	3-30MHz 100m-10m	SW broadcast, amateur radio & over the horizon aviation communication
Very High Frequency VHF	8	30-300MHz 10m-1m	FM, television broadcasts & line-of-sight ground-to-aircraft & aircraft- to-aircraft communication

Table 2.5: Table of Application of frequency band

ITU, stands for International Communication Union.

As earlier stated, the frequency band is eleven in number but only VHF is required within the scope of this project which is used both in frequency modulation broadcasting and television broadcasting. [10]

Radio frequency is a frequency or rate of oscillation within the range of about 3Hz and 30GHz. This range corresponds to frequency of alternating current electrical signals used to produce and detect radio waves. Since most of this range is beyond the vibration rate that most mechanical systems can respond to, RF usually refers to oscillation in electrical circuits [11]

CHAPTER THREE

3.0 Design, Construction and Implementation

3.1 Principle of Operation/ Block diagram

The principal mode of operation of this telephone FM transmitter is to transmit the audio signal coupled from the telephone.

In other words, the conversation between two parties is transmitted to an Fm band and broadcast over the radio wirelessly.

However, it can be deduced that the audio signal is FM modulated. The block diagram of the telephone Fm transmitter is as shown below:

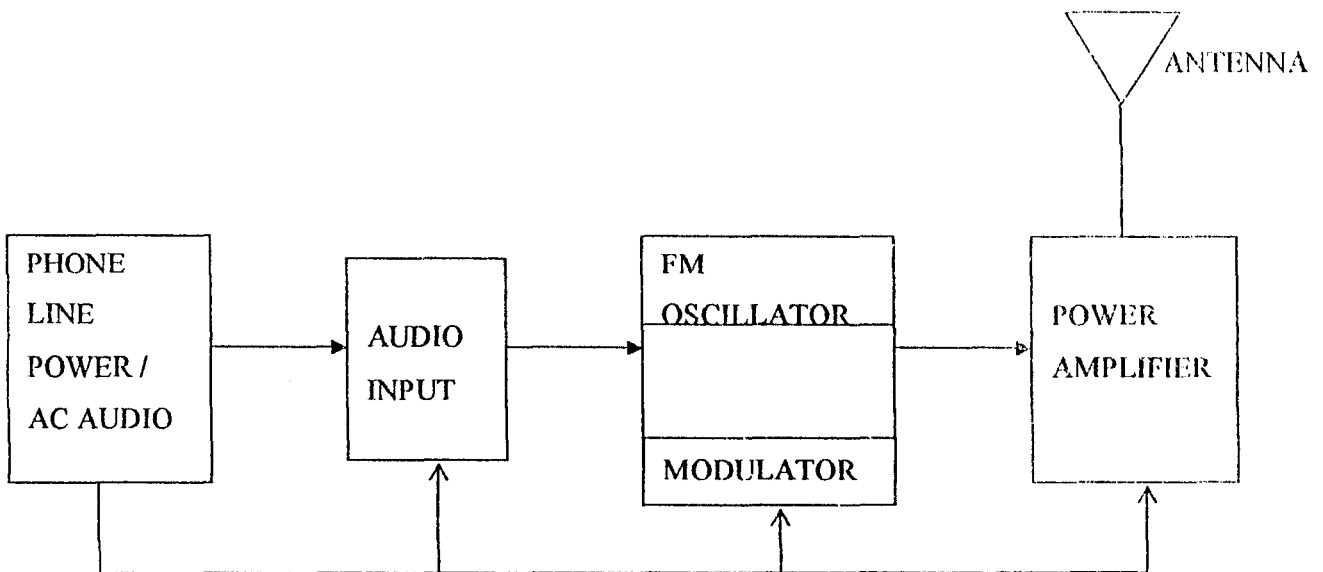

Fig 3.1: Block diagram of Telephone bug FM Transmitter

The design of the circuit when completed connects in series with either the tip or ring (green or red) leads of the telephone line. The power for the circuit is full wave bridge rectified from the phone line.[12]

3.2 Definition/Functional Part List of the Block Diagram

- Audio Input Module

This is where the audio signal from the phone line is fed into.

- The FM Oscillator/modulator Module

This is where the Radio Frequency (RF) carrier waves are generated and also where the audio signal is converted into an FM signal.

- The Power Amplifier Module

This section is responsible for the amplification of power for effective transmission/radiation.

- The Antenna

This is where the radio frequency (RF) output of the transmitter is coupled into free space.

3.3 Audio Input

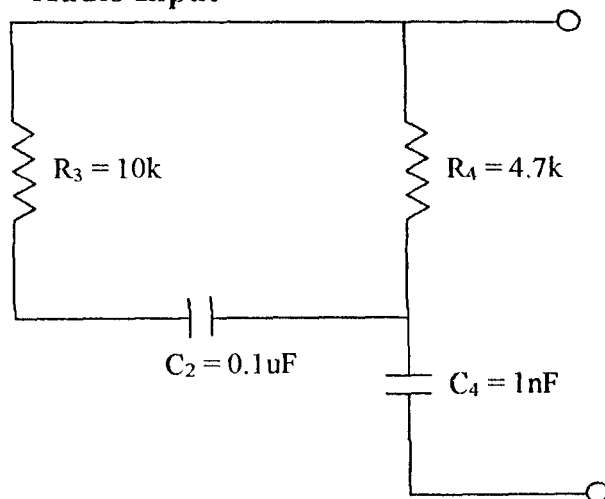

Fig 3.2: Circuit diagram of audio coupling network

Audio from the telephone line is coupled through resistor R_3 and C_2 . The values of R_3 and C_2 are $10K\Omega$ and $100nf$ respectively. R_4 is the resistance which supports or contributes to the base current biasing of the circuit.

$$\text{The biasing current } I_{is} = \frac{V_{DC}}{R_A} \text{-----(3.1)}$$

Where V_{dc} , is the supply voltage of the telephone line and R_A , is the resistance as defined above:

$$I_{bias} = \frac{48}{47 \times 10^3} = 1.0 \text{mA}$$

The audio signal was coupled to the input of the oscillator/modulator stage through C_2 , which is an 100nF capacitor. [12]

3.4 Design of the Oscillator/Modulator Stage

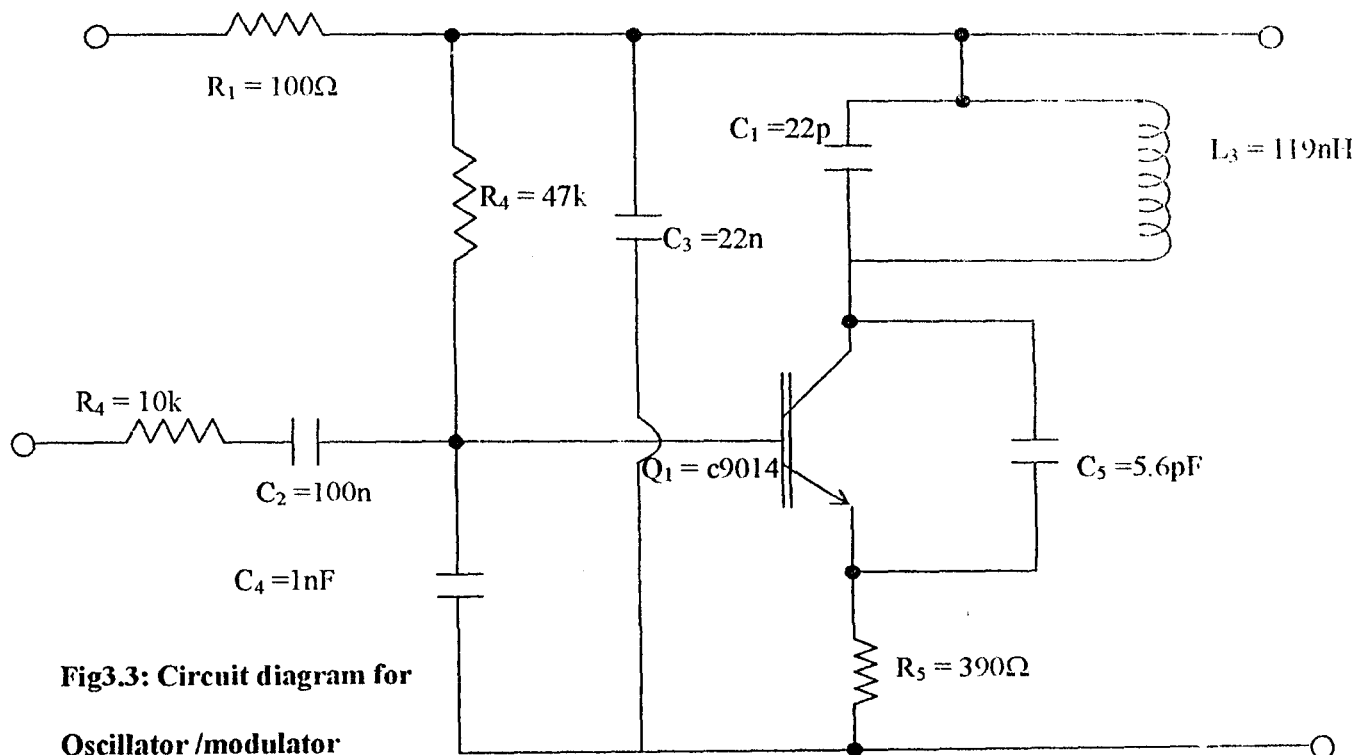

Fig3.3: Circuit diagram for Oscillator /modulator

The/an oscillator is an electronic circuit that produces a time varying signal without an external input signal using positive feedback. In other words, it is that circuit which produces a repetitive waveform on its output with only the dc supply voltage as an

input. A repetitive input signal is not required. The output voltage can be either sinusoidal or non-sinusoidal, depending on the type of oscillator used. [13]

One other function of the oscillator is to provide a high frequency signal called carrier wave.

Due to the high frequency of operation, a common-base oscillator was utilized as it provides the best performance of such frequencies (> 80MHz).

Based on the figure shown above, the common-base modulator/oscillator, Q1 is a high-gain C9014 NPN transistor indicated for high frequency operation (up to 200MHz).

In fig. 3.1 above, Q1 was configured as a common-base oscillator, CBO, with C4(1nF) providing AC path to ground for the oscillator.

R₄, biases on the oscillator, R₁C₁ are decoupling components for isolating the low power modulator stage from the high-power RF amplifier stage.

R₄, a 47KΩ resistance provides base bias current for Q1, the input audio signal was coupled into the base-emitter junction of Q1 by an RC network comprising a 10KΩ resistance and 0.1μF capacitance. The RC network forms a high pass filter of lower 3dB (FD3B) cut-off frequency.

$$F = \frac{1}{2\pi R_c} = \frac{1}{2\pi \times 10,000 \times 1 \times 10^{-6}} \text{----- eqn (3.2)}$$
$$= 159 \text{ Hz}$$

The frequency determining tank circuit was selected to oscillate at about 98.5MHz.

The circuit is basically a radio frequency oscillator that operates between 93MHz-105MHz. C₁, L₃, T₁, form the FM oscillator. Every transistor needs an oscillator to generate the Radio Frequency (RF) carrier waves.

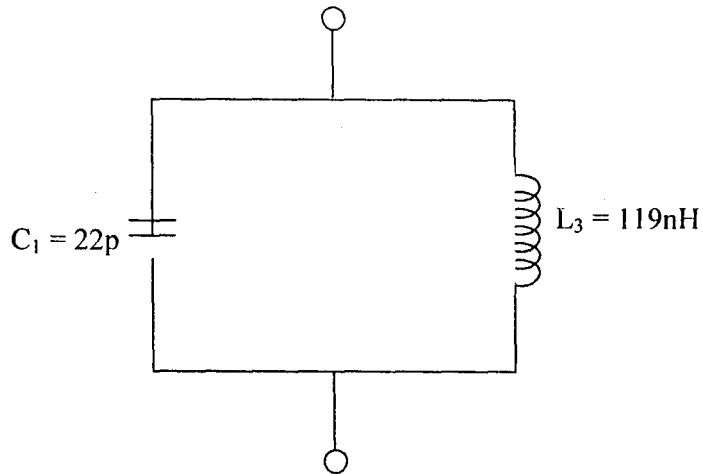

Fig 3.4: Tank circuit of the oscillator

From the equation, $F = \frac{1}{2\pi\sqrt{LC}}$, the value of the inductance needed for

oscillating of an unmodulated carrier frequency F_c of 98.5MHz is:

$$L = \frac{1}{4\pi^2 F^2 C} = \frac{1}{(4\pi^2) \times (98500000)^2 \times 22 \times 10^{-12}}$$

$$= 118.7nH$$

$$\cong 119nH$$

At resonance, $X_L = X_C$

For a 22pF capacitance,

$$X_C = \frac{1}{2\pi f C} = \frac{1}{2\pi \times f \times C}$$

$$= \frac{1}{2\pi \times 98500000 \times 22 \times 10^{-12}}$$

$$= 73.44\Omega \quad 3.3$$

Since at resonance, $X_L = X_C$ and in an ideal resonance circuit, $I_L = I_C$ but opposite in phase and hence will cancel each other.[13] [14] Hence, an ideal Circuit offers infinite impedance and acts as an 'open circuit'.

$$\text{Since } X_L = X_C = \frac{1}{2\pi fL}, \quad \text{Hence, } L = \frac{X_L}{2\pi f}$$

$$\text{Where } X_L = 73.44\Omega$$

f, is the chosen frequency of oscillator.

$$L = \frac{73.44}{2\pi \times 98500000}$$

$$= 119nH$$

The value of the inductor $L = 0.119nH$

To calculate the number of turns used, we shall employ the expression:

$$L = \frac{N^2 \mu A}{l} \text{-----(3.5)}$$

Where:

L = Inductance in Henry

μ = Permittivity of Air

A = Area of Cross-section

l = Length of Copper Wire Used

A 21.5 SWG wire of diameter .mm was used for forming the winding.

The diameter of wounded coil is 0.5cm as shown

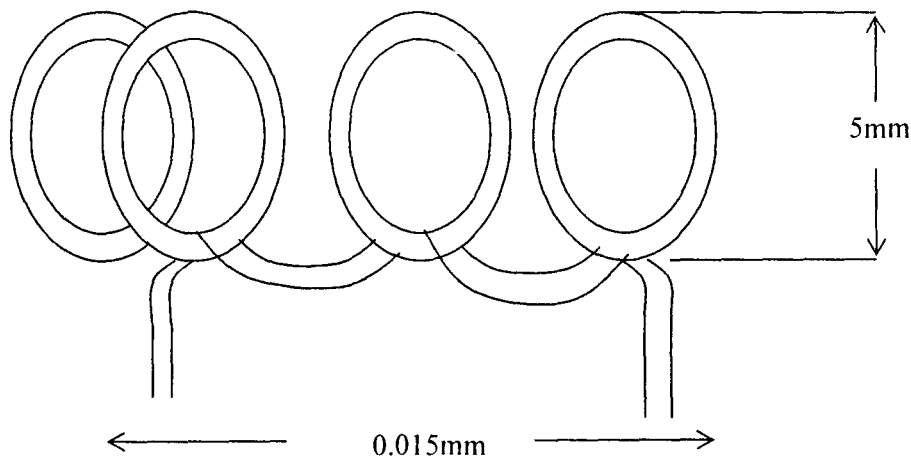

Fig 3.5: Inductor winding

$$Area = \pi r^2 \Rightarrow \frac{\pi d^2}{4}, \quad = \frac{\pi \times (5 \times 10^{-3})^2}{4}$$

$$= 19.634 \times 10^{-6} m^2$$

$$= 4\pi \times 10^{-7} wb / Am$$

$$= 0.015m$$

$$2 = \frac{L \times L}{\mu \times A}$$

$$= \frac{119nH \times 0.015m}{4\pi \times 10^{-7} \times 19.634 \times 10^{-6}}$$

$$= 72$$

$$N = 8.4 \approx 8 \text{ Turns}$$

But a 7-turn of wire was used and was extended to achieve the centre frequency of 98.5MHz, since fine tuning will also be needed to be achieved.

The tank circuit was placed in the collector circuit of the common base oscillator as shown below

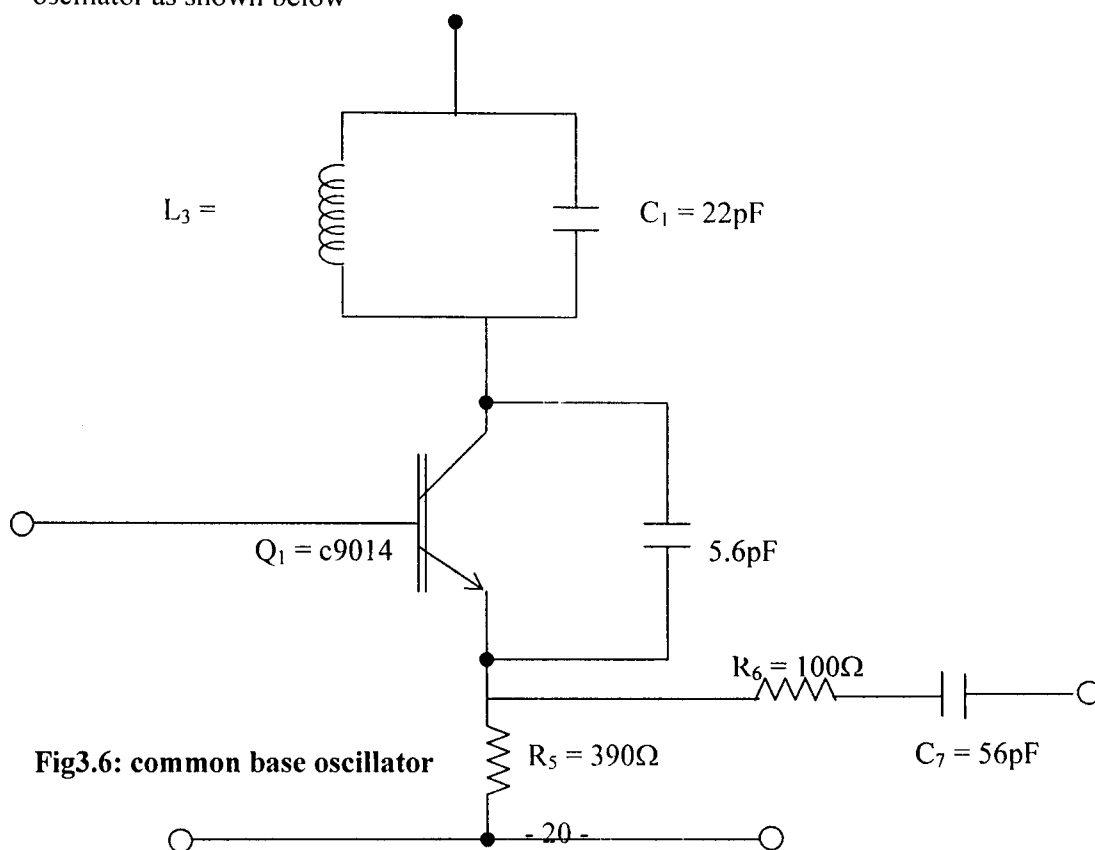

Fig3.6: common base oscillator

An oscillator requires positive feedback to start up and to maintain oscillation. In the modulator circuit, positive feedback is affected by a 5.6pF capacitor connected between the collector and the emitter of Q1

Since a common-base (CB) amplifier provides to phase inversion, the output current is fed back from the collector of Q1. Thus Q1 is in phase with the emitter input signal.

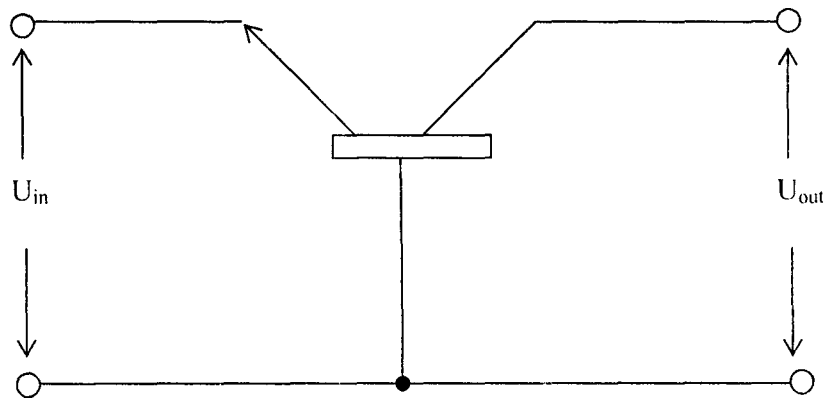

Fig 3.7: Schematic diagram of common base configuration

The oscillator current feedback through the 5.6PF capacitance develops a voltage across a 390ohm resistor. The output voltage is fed through a 5-6PF coupling capacitor into the RF stage.

3.4.1 The Modulator

The reactance modulator is a direct frequency generator. Frequency modulation was achieved by altering the collector emitter capacitance with respect to the input signal voltage.

Below is an illustration showing the basic principle of direct frequency modulator.

The modulating signal voltage is applied to the voltage variable reactance to vary its capacitance. The change in the capacitance alters the resonant frequency of the tuned circuit and so varies the frequency of oscillation. This way, the modulating signal modulates the carrier frequency.[15]

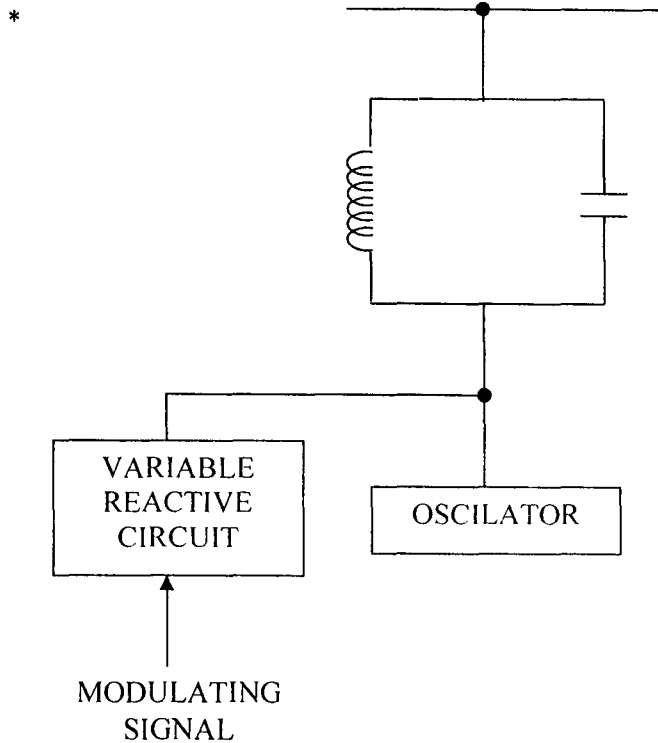

Fig 3.8: Typical Illustration of a Modulator

Since an unmodulated carrier frequency contains no information, modulation is consequently indispensable for transmitting the audio information superimposed on the DC voltage from the full wave rectifiers connected to the tip and ring of the phone box.

FM modulation implies the variation of the centre frequency with respect to the instantaneous amplitude of the input signal.

As one of the principal methods of Fm generation, the direct Fm generation was employed. The Fm wave is directly generated by altering a frequency determining component of IC tank circuit.

Direct FM generation can be categorized as or into two namely:

- i –Base reactance modulation,
- ii – varactor diode modulation

In (1), the effective tank capacitance is altered in consonance with the modulating input signal. In a BJT transistor, the CCE capacitance is a function of I_c . Since I_c is directly related to I_B . changes in I_c changes the collector emitter capacitance and since this capacitance appears in parallel with the tuned circuit, the total tank circuit capacitance is altered by altering I_c .

With no applied modulating voltage, I_B is constant; I_c is also constant and CCE assumes a mean value. If an audio input signal is fed into the base-emitter junction of the oscillator, I_B is varied with varying I_c .

The variation in I_c alters the effective capacitance seen by the tank circuit.

With a steady I_c :

$$F_{\Delta sc} = \left\{ \frac{1}{2\pi\sqrt{L(c + C_{CE})}} \right\} Hz \text{-----(3.6)}$$

With changing I_c

$$F_{\Delta sc} + \Delta F_{\Delta sc} = \left\{ \frac{1}{2\pi\sqrt{L(c + \Delta CE)}} \right\} Hz \text{-----(3.7)}$$

ΔF_{osc} causes the change in centre frequency corresponding to the information content of the transmitted carrier frequency.

3.5 RF Amplifier Stage

The L_1 , C_6 and Q_2 form the power amplifier circuit

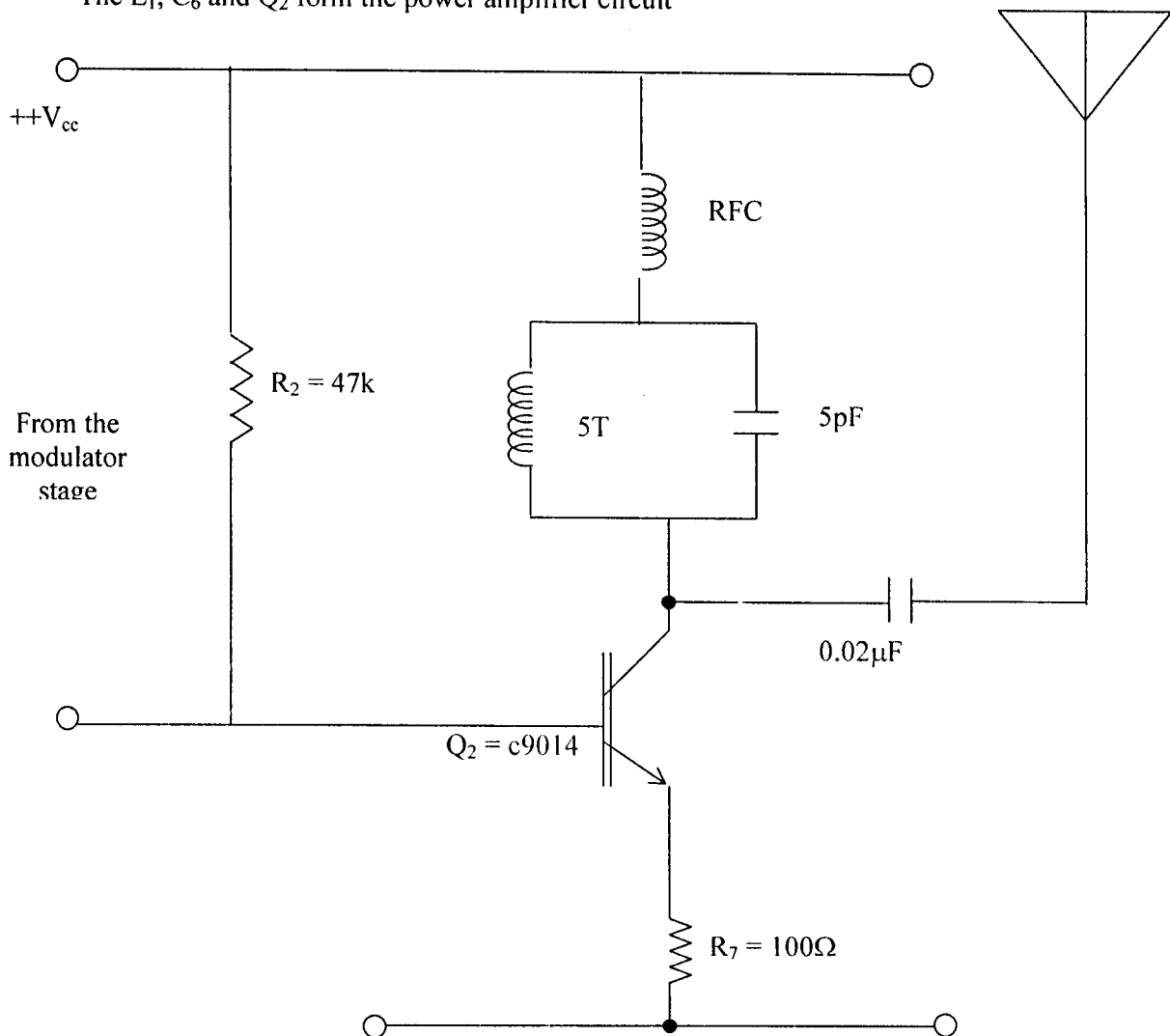

Fig 3.9: Circuit diagram of an RF amplifier stage

The circuit of fig 3.9 is the RF amplifier stage that drives the antenna.

The term 'power amplifier' is a relative term with respect to the amount of power delivered to the load and/or powered/sourced by the power from the phone line. In general, a power amplifier is designated as the best amplifier in transmission chain and is the amplifier that typically requires most attention for power efficiency.[17]

It is a single stage RF amplifier. It was used for increasing the output drive to the antenna.

The choice of the class of amplifier made is the class C type of amplifier. This is because, class C amplifiers have high circuit efficiency of about 88-90%.hence, they are used for high frequency power switch in radio transmitters since the provide high power output at the radio frequencies where harmonic distortion can be removed by simple circuits. [18]

A C 9014 NPN transistor was used for power amplification. The device was biased by a 47Kohm base resistance.

The tank circuit comprises a 5-turn inductance and a 51PF capacitance as shown above in fig ---- 3.9

3.5.1 The power amplifier design specifications:

Output power: 10mW

Maximum transmission range: 100meters.

Frequency range: 98.5MHz

Modulating frequency range: 3 kHz – 8 kHz

Velocity of light: 3×10^8 m/s

The C 9014 device has the following specifications:

Characteristics	Symbol	Rating	units
Collector current	Ic	150	mA
Dc current gain	Hfe	60 – 1000	
Collector-Base voltage	Vcbo	60	V
Emitter-Base voltage	Vebo	5	V
Collector-Emitter voltage	Vceo	50	V

Table 3.5.1: Table of maximum ratings / electrical characteristics

of C9014

Using the above transistor characteristics

$$V_{cc} = 48V, \quad V_{BE} = 0.65V$$

$$H_{fe} = 300$$

$$I_c = 150mA$$

For a class C amplifier, V_E is made about $\frac{1}{2} V_{CE}$

$$V_E = \frac{1}{2} V_{CE} \Rightarrow \frac{1}{2} \times 24$$

$$= 12V$$

$$R_E = \frac{V_E}{I_E}, \text{ Where } I_E = I_C = 150mA$$

$$R_E = \frac{12}{0.15}$$

$$= 80\Omega$$

An 100n resistance was used instead. The voltage across the tank circuit =

$$I_C \times R_C$$

$$I_C R_C = V_{CC} - V_{CE} - V_E$$

$$= 48 - 24 - 8$$

$$= 16V$$

$$X_{L1} = \frac{16}{0.15}$$

$$= 107\Omega$$

$$\text{But } L_1 = \frac{XL_2}{2\pi F_o}$$

$$\text{Where } f_o = 98.5\text{mHz}$$

$$L_1 = \frac{107}{2\pi \times 98.5 \times 10^6}$$

$$= 0.173\mu H$$

L_2 ; is also 0.173 μ H which is a radio frequency choke (RFC) that decouples power and audio from the amplifier circuit.

The base voltage of Q_E is

$$V_{B.E} + V_E = 12 + 0.65$$

$$= 12.65V$$

$$I_B = \frac{I_C}{H_{Fe}} = \frac{0.15}{300}$$

$$= 0.00057$$

$$R_B = (V_{CE} - V_{BE}) / I_B$$

$$= \frac{48 - 0.65}{0.005}$$

$$= \frac{47.35}{0.0005} = 94,700\Omega$$

A 47KΩ resistance was used instead

3.5.2 Power Calculation

Power intensity at a distance r(m) from the radiation source

$$\frac{P}{4\pi r^2} = \frac{E^2}{120\pi} \text{ (W/m}^2\text{)} \text{----- (3.9)}$$

$$120 \times P = 4\pi r^2 E^2$$

$$P = \frac{4\pi r^2 E^2}{120\pi}$$

$$= \frac{E^2 r^2}{30}, P = E^2 r^2 / 30 \text{----- (3.10)}$$

P = Power radiated by the transmitter antenna in watts

R = Maximum radius of the effectiveness of the system in meters.

E = Electric field strength at receiver antenna in V/m

R = Radiation resistance of antenna in ohms.

I = Current flowing through it in amperes

Then, radiated power is given by: $P = I^2 R$ watts

$$I = \sqrt{P/R} \text{----- (3.11)}$$

Putting equation 3.10 into 3.11 yields

$$I = \sqrt{E^2 r^2 / 30R} \text{ ampere 3 eqn----- (3.12)}$$

Putting r = 50meters, E = 3000 x 10⁻⁶V/m into equation 1 gives

$$P = \left(\frac{300 \times 10^{-6} \times 50}{30} \right)^2 = 0.259W$$

$$V = f\lambda$$

3.5.3 Power Supply/ Led Indicator

The voltage used for powering of the circuit was 48V; assuming standard voltage level of a telephone land line.

The LED Indicator is connected to the source via a series limiting resistor as shown below. The LED Indicator simply indicates when the circuit is powered on (LED glows).

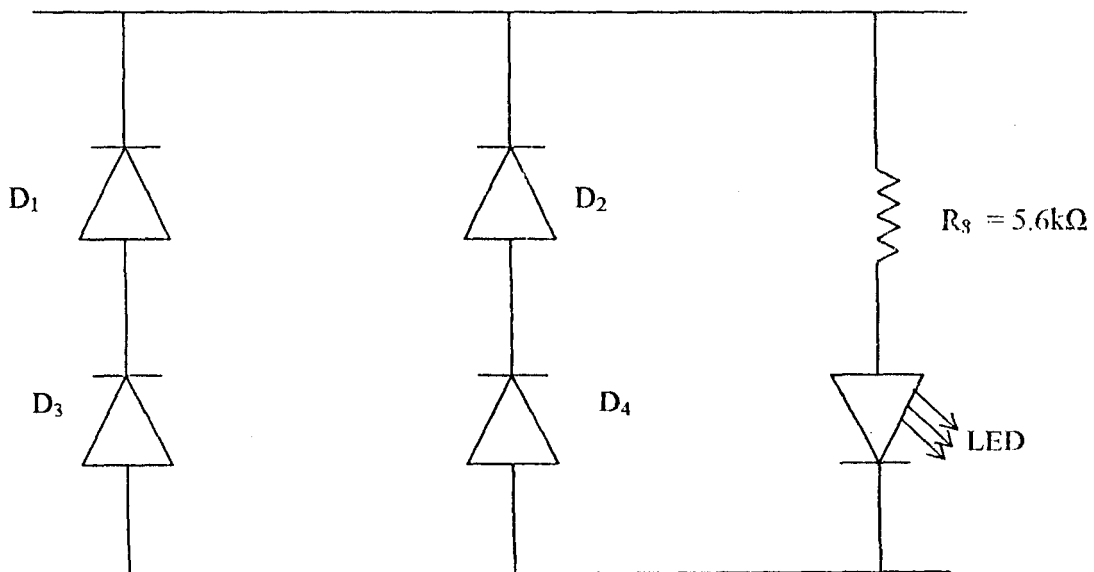

Fig 3.10: Led Indicator

The calculation is as shown below:

$$R_8 = \left[\frac{V_{IN} - V_{LED}}{I_{LED}} \right] \text{-----(3.13)}$$

$$V_{IN} = V_S = 48\text{volt}$$

$$V_{LED} = 2.5 \text{ volt for (green LED)}$$

$$I_{LED} = LED \text{ current} = 20 \text{ mA}$$

$$R_s = \left[\frac{48\sqrt{2} - 2}{20 \times 10^{-3}} \right] = 3.29 \times 10^3 \Omega$$

$$\approx 3.3 \text{ k}\Omega$$

Hence, a resistor of $3.3 \text{ k}\Omega$ was used so as to reduce the amount of current that the LED draws. Since the pulsating AC signal may not possibly go beyond 48 volts; the $3.3 \text{ k}\Omega$ resistance is perfectly okay.

3.6 Antenna

An antenna is a device that transmits and/or receives electromagnetic waves. Oftentimes, electromagnetic waves are often referred to as radio waves. Most antennas are resonant devices, which operate effectively over a relative a narrow frequency band.

An antenna must be tuned to the same frequency band that the transmitter which it is connected to operates. If this is not so, transmission or reception may be impaired.

Efficient antenna configuration often has an impedance of around 50Ω or higher. This is why antenna matching is done to match this value.

At 98.5 MHz operating at resonant frequency, the operating wavelength is

$$\text{given to be: } \lambda = \frac{V}{f} \text{-----(3.14)}$$

Where: $V = \text{speed of light} = 3 \times 10^8 \text{ m/s}$

$\lambda = \text{wavelength in meter} = ?$

$f = \text{the resonant frequency}$

$$\lambda = \frac{3 \times 10^8}{98.5 \times 10^6}$$

$$= 3.046 \text{ meter}$$

For efficient radiation

Antenna length, [$\geq \frac{1}{4}$]

But $L = \frac{1}{8} \lambda$ Was used instead

$$= (1/8 \times 3.046) \text{ m}$$

$$= (1/8 \times 304.6) \text{ cm}$$

$$38.075 \text{ cm}$$

3.7 Audio Modulating Voltage

The audio modulating voltage was derived from a full-wave bridge rectifier as shown below:

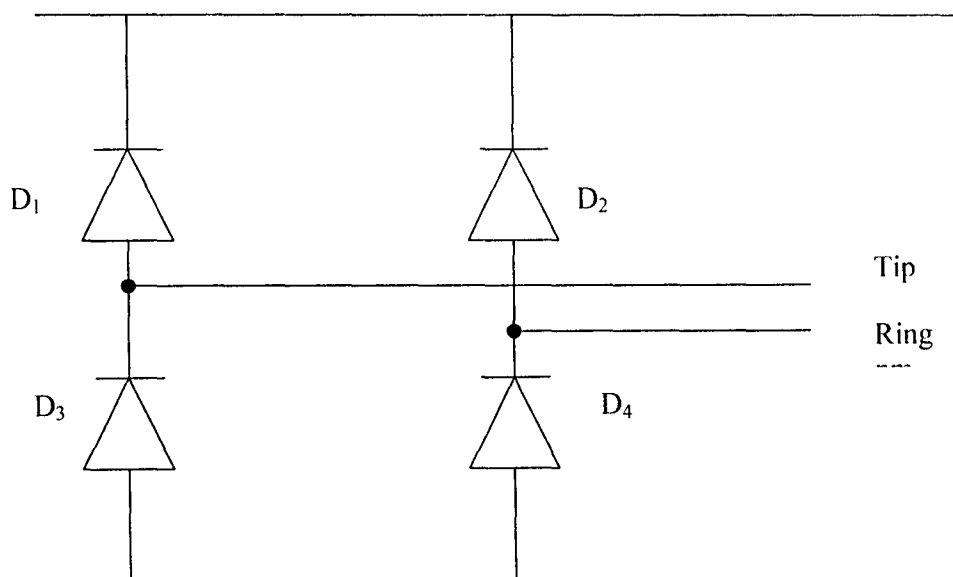

Fig.3.11: Audio Voltage Modulating Diagram

The audio signal is superimposed on the 48V AC voltage from the telephone switching network. The AC voltage, with the superimposed audio signal is applied to a four diode bridge rectifier as indicated above.

The AC voltage was converted to a pulsating DC at a frequency dictated by the audio component. A smoothening capacitor was not used as this would filter out the audio message to be transmitted.[18]

The audio frequency information is impressed on the carrier frequency by the $10K\Omega/0.1\mu F$ network in the based load of the modulator.

The RF component modulates the 98.5MHz frequency which was radiated by the antenna.

3.8 Design Implementation

The project implementation started with putting together all necessary components for the construction of the Fm telephone transmitter circuit.

In this process, certain ICs were out of reach and the closest substitutes were gotten.

Construction of the project was directly built on a vero board owing to the behavior of RF circuits on bread board, which is anomalous in behavior. These behaviors include: instability and interference.

When constructing, construction was initiated by first installing the resistors and the diodes on the vero board.

The next step was to install the inductor coils L1 and L2, 5-turns each of enameled copper wire with standard wire gauge of 21 ½ and 2 1/8 inch drill bit of winding former.

Before the leads of the inductors were soldered, the edges were first burnt off to remove insulation and to ensure that solder holds it firmly to the board.

L3 is an 7-turn inductor which is spread apart by 2mm.

Next step was to install the fixed capacitors and finally soldering the transistors Q1 and Q2 to their appropriate places.

Finally, the antenna was fixed to the collector of the power amplifier circuit and a transistor digital radio was used to test the wireless Fm telephone transmitter.

Attached overleaf is the complete circuit diagram of the telephone transmitter.

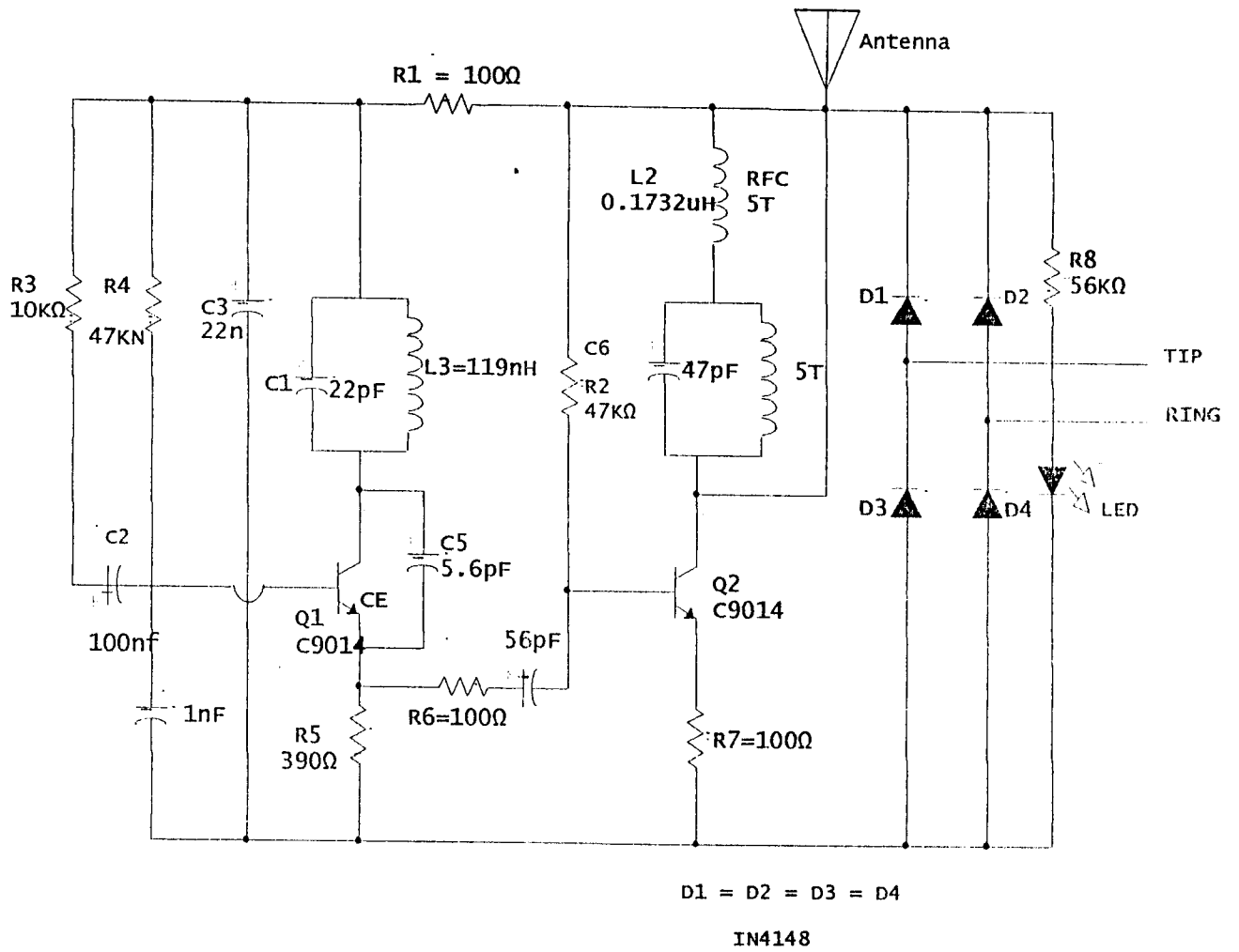

Fig 3.12: The overall circuit diagram

CHAPTER FOUR

4.0 Test, Results and Discussion

The testing of my project was carried out at the Nigerian Telecommunications (NITEL) main distribution frame (MDF)/ the exchange units of the aforementioned company in Minna.

Before discussing the processes and steps taken at the NITEL MDF unit for testing the functionality and workability of the telephone bug Fm transmitter, some very preliminary tests were equally carried out.

This will be discussed as follow:

A frequency of 50HZ from an AC source of a 220V socket outlet was stepped down to 12V using a voltage step down transformer.

The 12V, 50Hz AC was connected to the rectifier module of the completed circuit design or device. It was actually intended that the 50Hz be used to modulate the oscillator as the assumed carrier frequency.

The above attempt actually produced a result – the provided or yielded result is the fuming of the AC voltage signal applied.

The design was carried out using 98.5MHz as the modulating frequency signal. But based upon the preliminary test conducted as explained above, signals transmitted were received on 95.5MHZ with a maximum range of about 21 meters from line of sight.

4.1 Main Constructed Circuit Tests

After the final packaging, using the main distribution frame of NITEL, the various tests that were conducted include

1. Test on the effective range of transmission.
2. The DC voltage level of the telephone line.

3. The quality of the reception of the receiver.
4. The picking of dialing tones.

4.2 The Power Supply Stage

The standardized DC voltage level of the phone line was tested using an analogue meter. The required result was 48V Dc and this is exactly the result obtained from the test.

4.2.1 The Range of Transmission

The audio signals were picked with the receiver at a distance of about 30.5meters on a flat open space within line of sight.

When the same test were conducted in a building with wall constituting barriers to the transmitter, and the receiver, the distance was reduced to about 21 meters. This was made possible by using a digital transistor radio.

4.2.2 Quality of Reception

A digital transistor radio was used to determine the spots at which receptions of signal are faded more for optimum reception however, the closer the device is, but not less than 15 meter, the better.

4.3 Alignment Stage/Procedure

For this stage, four basic tools were employed; namely:

- The audio/transistor radio receiver
- The telephone line
- The alligator/crocodile clips
- The cutting pliers

4.4. Procedures

- a. The alligator clips/crocodile clips are attached to the extended ends of the connecting coaxial cable of the device, this is followed by cutting the phone line.
- b. Having tested the voltage level, the device is interfaced and powered with a LED indicator indicating that the device is ready.
- c. The antenna of the telephone Fm transmitter is extended and walking away from the point of transmitter, the antenna of the transistor radio receiver was also extended and switched on
- d. The channels are tuned to between 95.5 and 98.5MHZ to search for dialing tones.
- e. With the Fm band tuned to 97.8MHZ and 98.2MHZ, signals were picked. However, the signal was found to be more stable at 98.2MHZ.

It should sometimes be noted that radio frequencies may not just be stable. Hence, it can be deduced that owing to frequency variation, a tolerance band of ± 0.3 MHZ is permitted.

4.5 Further Discussion of Results

- i From the result obtained from the test, the design is said to be in good order.
- ii The target range of transmission was 30.5M.
- iii The voltage level was perfect at 48Volt.
- iv The frequency band of effective or optimum reception is 98.2MHZ with the target set at 98.5MHZ.

4.6 Limitations

- * The inability to test frequency at the various levels using spectrum analyzer.
- * Difficulties in getting the exact components. Hence, the use of equivalent components was considered
- * The inability of getting an RF power meter which is required to determine the power coupled into space of the RF stage.

4.7 Trouble Shooting

1. If the telephone Fm transmitter does not come on:
 - * Check if the LED is powered ON or Not
 - * Check the voltage level of the line.
2. If the receiver (transmitter radio) is not responding:
 - * Check if the connection between phone line and device is intact.
 - * Fine tune the receiver as well.
3. If there is trouble finding a spot on the dial that is quiet enough, the turning area can be moved up to the desired frequency by replacing C_1 with a lower value.

CHAPTER FIVE

5.0 Conclusion

In conclusion, having examined the design and the construction of the whole project, the aim of the project can truly be said to have at least met design specification. For optimum performance of the circuit, proper soldering should be ensured since RF circuits are highly sensitive. The telephone bug FM transmitter is a portable device that was designed considering its economic relevance using available local components

5.1 Summary

The telephone bug FM transmitter is capable of handling frequencies between 95.5MHz and 98.5MHz. The telephone bug FM transmitter actually consists of three stages, namely; the power/audio input stage, the modulator/oscillator stage and the power amplifier stage which drives the antenna.

The audio/power is first coupled from the phone line to the components. The oscillator generates a carrier wave, which is a high frequency carrier signal. The modulator imposes a particular electric message on the carrier wave that is generated by the oscillator.

Following the oscillator/modulator stage is coupled to the power amplifier stage from the later output. The power amplifier finally amplifies the output high enough to drive the antenna. The signal radiated from the antenna is an electromagnetic wave which is received by any receiver tuned to 98.5MHz with the area of coverage within 30 meters.

5.2 Problems Encountered

The problems encountered in the course of the design and constructions are:

- ii. Difficulty in obtaining the calculated length of the antenna, this was remedied by using an adjustable length of antenna.
- iii. Unavailability of desired components. This was remedied by using available local component.
- iv. Instability in the variation of electromagnetic waves which really posed some challenges as to what frequency modulation band should be specified.

5.3 Areas of Possible Improvements

1. Using of global system for mobile communication equipments (GSM) instead of telephone land lines.
2. The effective range can be increased and using a very high frequencies.
3. Using of digital transmitters instead of the analogue type that employs inductive coils of wire.
4. Designing of the amplifier with a powerful in-built antenna to enhance portability.
5. The incorporation of an in-built memory for a voice record in place of a radio/tape recorder

5.4 Recommendations

The following under mentioned are highly recommended in the cause of future design and construction on this project by any interested student.

1. Course like analogue and digital electronics should be made practical oriented. This can be achieved by dividing the practicals involved into modules.
2. Every student should be familiarized with the idea of student – lecturer's supervision by means of giving students form levels 300 – 500, project

works to do either collectively or personally. This will also take good care of the areas of possible mistakes that may arise at final year project class.

3. Adequate equipments should be provided by the departments that will enhance students to test their work in modules.
4. Extra-classes may be encouraged for extra learning on circuits design and construction.

REFERENCES

- [1] Wikimedia Foundation Inc.: Telephone <http://en.citizenidm.org/wiki/telephone>
- [2] History AT&T 2006. <http://www.corp.att.com/history/milestone.html>
- [3] Bern Dibner, Burndry Library Inc.: The Atlantic Cable 1995.
- [4] <http://history.acusd.edu/gen/media/Historyofradio.htm>.
- [5] Microsoft Corporation 'Microsoft Encarta' 2006 Edition
- [6] Andrees F. Molisch 2005 'wireless communications' pp4 ISBN: 0-470-84888-X
- [7] Bernard and George 1993. George1993, George Kennedy and Bernard Davis, 'Electronic Communication Systems' (4th Edition), pp1-3, pp80, pp85, pp79 and 82-84 ISBN:0-07-463682-0.
- [8] Y. A. Adediran, Telecommunication Principles and Systems, Finom Associates, Minna Nigeria. January 2005, pp.19 ISBN:978-36535-0-4.
- [9] Wikimedia Foundation Inc., Electromagnetic Spectrum
<Http://en.wikipedia.org/wiki/electromagneticspectrum>
- [10] Wikimedia Foundation Inc., Radio-Frequency
<Http://en.wikipedia.org/wiki/Radio-Frequency>.
- [11] Wikimedia Foundation Inc., Electromagnetic Radiation
<Http://en.wikipedia.org/wiki/electromagneticradiation>
- [12] T. L. Floyd 2007, Electronic Fundamentals Circuits, Devices and Application, (9th Edition), pp. 793.
- [13] Poptronix Handbook <http://www.poptronix.com>. Pp1,pp3
- [14] M. L. Anand 2000 Electronics Principles Devices and Circuits (1st Edition). Pp. 65.
- [15] <Http://ar.epinasoft.com>, last updated April 17, 2006.
- [16] Hans Lohningeo, Basic Radio Last Update April 7, 2006 <http://ar.epinasoft.com>.
- [17] B. L. Theraja and B. K. Theraja (16th Edition) Textbook of Electrical Technology, (23rd Edition) pp. 1936, pp. 2076.
- [18] Electrical Engineering Training Series, A Basic Transistor Amplifier.
<Http://ar.t.pub.com/neets/book7/2sl.htm>.
- [19] Shruder (1991) Electronic Communication, (6th Edition) Waynet.,

[20] Prof. Uriah Oria,(2004), 'Research project made easy in electrical/electronics engineering,' 1st edition ECAS,pp228,229,234,235

[21] Led Centre: Characteristics of Led <http://led.linear.org/> what are the Electronic characteristics of Led.

APPENDICES

- 1.0 The encasement of the finished project work
- 2.0 The data sheet of the characteristics of C9014
- 3.0 The operational manual
- 4.0 The cost analysis of the project work

APPENDIX ONE

1.0 The Encasement Of The Project work

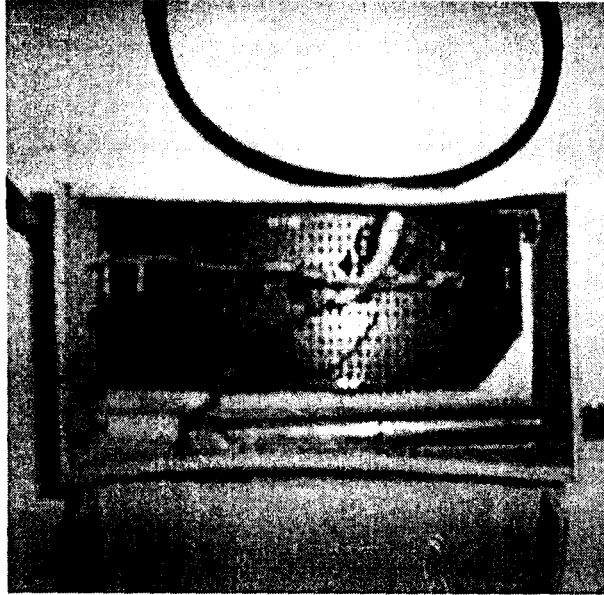

Picture 1

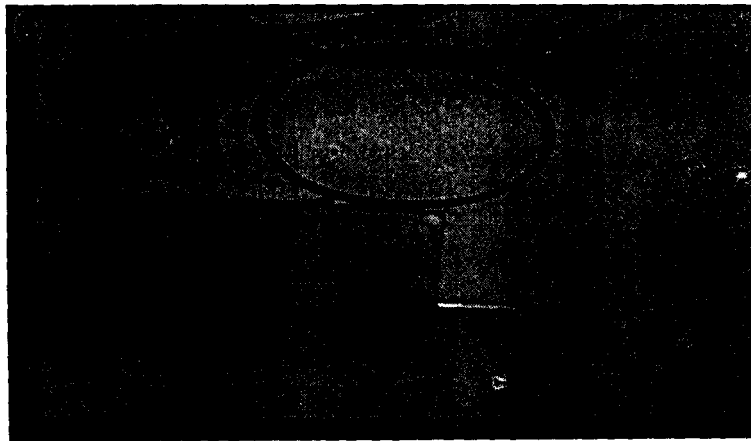

Picture 2

GENERAL PURPOSE APPLICATION.
SWITCHING APPLICATION.

FEATURES

- Excellent h_{FE} Linearity
: $h_{FE}(I_C=0.1mA)/h_{FE}(I_C=2mA)=0.95$ (Typ.)
- Low Noise :NF=1dB(Typ.) at $f=1kHz$,
- Complementary to KTC9015.

MAXIMUM RATINGS ($T_a=25^\circ C$)

CHARACTERISTIC	SYMBOL	RATING	UNIT
Collector-Base Voltage	V_{CBO}	60	V
Collector-Emitter Voltage	V_{CEO}	50	V
Emitter-Base Voltage	V_{EB0}	5	V
Collector Current	I_C	150	mA
Emitter Current	I_E	-150	mA
Collector Power Dissipation	P_C	625	mW
Junction Temperature	T_j	150	$^\circ C$
Storage Temperature Range	T_{stg}	-55 ~ 150	$^\circ C$

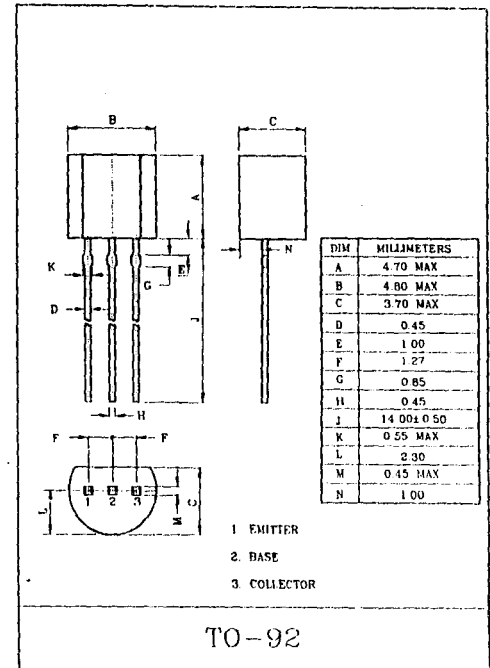

ELECTRICAL CHARACTERISTICS ($T_a=25^\circ C$)

CHARACTERISTIC	SYMBOL	TEST CONDITION	MIN.	TYP.	MAX.	UNIT
Collector Cut-off Current	I_{CBO}	$V_{CB}=50V, I_E=0$	-	-	50	nA
Emitter Cut-off Current	I_{EBO}	$V_{EB}=5V, I_C=0$	-	-	100	nA
DC Current Gain	h_{FE} (Note)	$V_{CE}=5V, I_C=1mA$	60	-	1000	
Collector-Emitter Saturation Voltage	$V_{CE(sat)}$	$I_C=100mA, I_B=10mA$	-	0.1	0.25	V
Transition Frequency	f_T	$V_{CE}=10V, I_E=-1mA, f=100MHz$	60	-	-	MHz
Collector Output Capacitance	C_{ob}	$V_{CB}=10V, I_E=0, f=1MHz$	-	2.0	3.5	pF
Noise Figure	NF	$V_{CE}=6V, I_C=0.1mA, R_g=10k\Omega, f=1kHz$	-	1.0	10	dB

Note : h_{FE} Classification A:60 ~ 150, B:100 ~ 300, C:200 ~ 600, D:400 ~ 1000

APPENDIX THREE

3.0 The operational manual

- Connect the transmitter to the phone line using whatever method you prefer.
- Turn on a nearby radio and tune to a quiet spot on the dial somewhere between 95.5 and 98.5MHz.
- Pick up the phone, you will here a dial tone right away on the FM radio,
- If this is not so you can fine tune the FM radio for better reception
- Since there is no a tuning capacitor, the inductance of the coil can be varied
- It should be noted too that the tuning area can be moved up from 98.5 to 108.5MHz by replacing C1 by 10pF capacitor

APPENDIX FOUR

4.0 COST ANALYSIS

COMPONENTS	NO	VALUES	PRICE
Resistors R1	1	100Ω	N10:00K
R2	1	47KΩ	N10:00K
R3	1	10KΩ	N10:00K
R4	1	47KΩ	N10:00K
R5	1	390Ω	N10:00K
Capacitors C1	1	22Pf	N30:00K
C2	1	100nf	N15:00K
C3	1	22nf	N20:00K
C4	1	1nf	N15:00K
C5	1	5.6pf	N20:-00K
C6	1	47pf	N20:00K
Diodes D1-D4	4	IN4148	N120:00K
Transistors T1-T2	2	C9014	N120:00K
Inductors LI		5 Turns	N10:00K
L2		5 Turns	"
L3		7 Turns	"
VERO BOARD	1		N60:00K
ANTENNA	1		N80:00K
CASING	1		N150:00K
WIRES			
Resistors R6-R7	2	100Ω	N10;00K
R8	1	56KΩ	N10:00K
LED	1		

TOTAL = N710 :00K