

**DESIGN AND CONSTRUCTION OF
AN ADJUSTABLE
ELECTRIC ROOM HEATER**

BY

**NURA ISAH BABURA
2000/11142EE**

**A Thesis submitted to the
Department of Electrical and
Computer Engineering,
Federal University of Technology,
Minna, Niger State, Nigeria**

NOVEMBER, 2007.

DEDICATION

I dedicated this project to my beloved parents, Mr and Mrs
Haruna Mu'azu.

DECLARATION

I Nura Isah Babura declare that this work was done by me and has never been presented else where for the award of a degree. I also hereby relinquished the copyright to the Federal University of Technology Minna.

NURA ISAH BABURA

ENGR. Y. A. ADEDIRAN

Name of student

Name of Supervisor

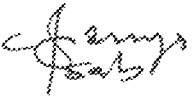
03/12/07

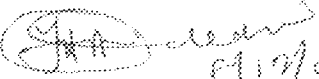
01/12/07

(Signature and Date)

(Signature and Date)

ENGR. M. D. ABDULLAHI

Name of HOD

Name of external Examiner

(Signature and Date)

(Signature and Date)

ACKNOWLEDGEMENT

I thank Almighty Allah for seeing me through the degree program.

I am grateful to my parents, Mr and Mrs Haruna Mu'zu for their immense love, sacrifice and care for me, you are of course role models for posterity. I would like to thank my ever supportive siblings. My thanks also go to my supervisor, Engr Dr Y.A Adediran for his detailed supervision, and sincere assistance. And also to my Head of Department, Engr. M. D Abdullahi for his genius and striking humility.

I am grateful to Dr Bala Mohd Dewu (Abu Zaria), Mr Magana, Engr E.O Agbagwa (PHCN), Mr Abdul – Aziz Sale, Ibrahim Abubakar Zago and A.S Usman for their morel Support.

Special thank goes to my wife Madina Lawan chiroma for her patience, courage and for been supportive throughout the program. I also thank all my friends.

ABSTRACT

The project was designed to provide a alternative to local way of room heating; as it offers temperature selections. A solid state control that has been employed, proved to be more effective since it has no moving part like that of relays and thermo starts.

The sensor provides a precise temperature monitoring and prompt isolation of the heating element. LM35 a temperature sensor with high precision was incorporated to the circuit.

The design specifically is targeted at single (room) users for their comfort. Although larger rooms can also be served when heater is operated at maximum setting.

LIST OF FIGURES

- Fig 1.1 Block Diagram of an adjustable room heater
- Fig 2.1 Convector heater
- Fig 2.2 Simmer start Energy Control
- Fig 2.3 The Three heat switch system
- Fig 2.4 Switch contact position In three heat switch
- Fig 3.1 Regulated power supply circuit diagram
- Fig 3.2 Astable Vibrator
- Fig 3.3 Ramp generator
- Fig 3.4 Potential Divider network
- Fig 3.5 D.C Comparator
- Fig 3.6 Pulse width modulator (generator)
- Fig 3.7 Output of the pwm generator
- Fig 3.8 A . C Solid state switch (optotraic)
Controlled by NPN transistor
- Fig 3.9 Enternal Triac controlling the heating element
- Fig 3.10 Temperature sensing unit.
- Fig 3.11 Over temperature detector
- Fig 4.1 Assemble for an adjustable room heart
- Fig 4.2 List of components

TABLE OF CONTENTS

CONTENTS	PAGE
Dedication	ii
Declaration	iii
Acknowledgement	iv
Abstract	v
List of Figures.....	vi
Table of Contents	vii
CHAPTER ONE: Introduction:	
1.1 Historical Background	2
1.2 Aims and Objectives	3
1.3 Scope of the study	4
1.4 Method of the study	4
1.5 Block Diagram of Adjustable Room-Heater	5
CHAPTER TWO: Literature Review	
2.1 Evolution of the Room Heaters	6
2.2 Theoretical background	8
2.3 Home heating system	10
2.4 Effect of Heat on other devise	13

CHAPTER THREE: Design Analysis

3.1	Power Supply Sub unit	15
3.2	Control Circuit	18
3.3	Switching Circuit	24
3.4	Power Developed in the heating element	25
3.5	Temperature Sensing Unit	26
3.6	Over temperature detector	27
3.7	Circuit Diagram for an Adjustable Electric Room-Heater	29

CHAPTER FOUR: Construction and testing

4.1	List of components	30
4.2	Construction	31
4.3	Principle of operation	34
4.4	Testing	35
4.5	Problems encountered	35

CHAPTER FIVE: Conclusion and Recommendations

5.1	Conclusion	36
5.2	Recommendation	36
	References	37
	Appendix	38

CHAPTER ONE

INTRODUCTION

Design and construction of an Adjustable Electric room Heater is a project embarked upon so as to provide a simple modern way of room heating system with low power consumption and at an affordable price. It is designed in such a way that a single user could employ its services – especially during the Hammatan and rain seasons, when temperatures drop to between 18°c and 22°c [1]. Some times between March and April, every year a maximum temperature of about 35°c to 37°c is recorded in some parts of this country. Places such as Jigawa state, Kano, Sokoto, Zamfara and Maiduguri record the highest temperature during the period mentioned above. Therefore, for the people of these states temperature of 18°c or even 22°c is very undesirable to their body systems. This also applies to some other people across the country. Obviously being one of the people usually affected by the cold weather, that actually leads to the development of this idea that is, design and construct a portable electric room heater at school level. In the same manner, it has been established world over that human bodies need to be maintained at certain temperature level that is, certain quantity of heat need to be maintained in the body system (human body) for it to function properly. The quantity of heat helps to develop ones mental stability especially in a weather friendly environment.

In this design the main device used is an electric heating element; it is controlled through electronic devices. The heating element maintains the room temperature based on the principle of heat transfer that is, a situation where a heated substance will give off heat to another substance at low temperature [2]. The three ways by which heat can be transferred are: Conduction, Convection and Radiation.

Convection method of a heat transfer is the most effective way by which room heating is achieved. Convection can be described as the constant flow of air upward a cross-heated element, the heated air in contact with the heated element expands and raises, cool air flowing in to take its place. However, for this project work, a small fan motor is used to fasten this process of convection, and correspondingly gives an effective and balance distribution of heat within the various parts of the room in which the heater is connected.

1.1 Historical Background.

Design and construction of a portable electric room heater of this type is an attempt to provide a smaller, robust and moveable heating unit that could be use for a human's comfort. Although it is not the first, since many of its type have been developed, manufactured and marketed by the developed Nations of the world. However, prior to the development of those available in the market, several attempts have also been made to find the appropriate ways of warming bodies. It is this desire for warmth and comfort that may have motivated people's first use of fire. Evidence shows that man used wood and charcoal in an open fire to provide warmth for his body system; as well as prepare his daily meal. Such simple open fires were used up till late 19th century world over. This method of heating provides an escape opening for the smoke and for the safer utilization of the process.

Meanwhile, in search of better method of providing warmth to his body man was able to develop and use STOVE. This serves as an alternative to an open fire method. The stove gives off fire through a combustion chamber usually made of ceramic or Iron Materials; the heat produced by this chamber is transferred to the stove's walls through a convection current of the hot air which in turn heats the room. Meanwhile as the technology advanced individual

room stoves were superseded by a central heating system for the entire buildings [3]. In most of the developed nations public and commercial buildings are kept at normal and comfortable temperatures all year round as a result of invention of the central heating systems. In these areas a complex heating system is designed so as to satisfy the safety requirements and the comfort of an average user. However, there is a greater variation in the physiological response of people to their immediate environment or climatic conditions .As a result, many people develop a feeling of a kind of frustration while using public utilities; in which case they are some times forced to adopt to situation not of their liking that is, the Idea of central heating may not go down well with others while others enjoys the Idea.

Now, from the presentation above, one could see that several efforts have been made to provide a heating system from various sources and in different forms. Therefore, it has become imperative, to develop a simple user and low power consumption electric room heating system that is, capable of providing instant, adjustable and safe body warmth. Even through not as invention but to server as an improvement of its clones.

1.2 Objectives

The main aim of this project is to design a room heating system that is capable of providing an adjustable temperature control. The unit is powered by 240v / 50HZ a.c supply. This objective could be achieved by regulating the amount of power delivered to the resistive element. The temperature control is present manually. A sensor LM35 is incorporated in to the design so as to continually monitor the preset temperature of the device, which invariably keeps the room's temperature at the required level. The temperature regulation of the device is within the range of 23°C to 45°C.

1.3 Methodology

In the design method, the circuit was divided into sub-system. The mode of operation of each sub-system was explained for the readers understanding. These subsystems, when joined together will give the whole circuit layout in a simple manner. The process followed will help in achieving the objective of this project.

1.4 Scope of the Study

This design work is targeted at providing a device that could be presented as a final year project. However, a well finished with a temperature display, can profitably be marketed to the general public. Triac as a power-switching device controls the operation of the heating element. The gate current of the triac is controlled by the action of the comparator and NPN transistor connected to the circuit. The comparator supplies the gate current to the external triac via the NPN transistor (Q1) and op-to triac MOC3023. But as the temperature rises and approaches the preset limit the sensor sends a signal through the second NPN transistor (Q2) forcing Q1 to go off, thereby cutting off gate current to the external triac. This, in turns switches "OFF" the heating element. However, as soon as the temperature drop below the preset limit Q1 turn "ON" and allows gate current flows through both op-to triac and external triac respectively. At this juncture the heating element is switched "ON" again.

1.5 Limitations

Some imperfections may arise during the useful life of the device because, of the temperature effect on some components used in the design. Another limitation in this design is that temperature display is not provided. The device is dependent of power supply (not useful where there is no electricity supply). It is also weather dependent. (Not suitable for a hot weather)

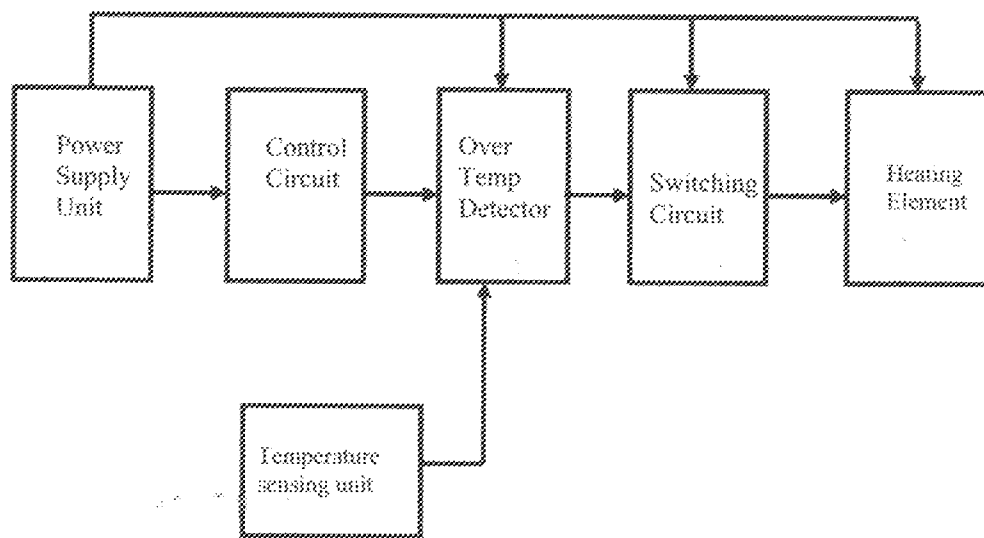

Fig. 1.1: Block Diagram of an Adjustable Electric Room-Heater.

CHAPTER TWO

LITERATURE REVIEW

2.1 Evolution of Room Heaters

Saunas are the first generation of the room heaters developed by Finns in Finland. It is a Finnish small room or house designed to experience dry and wet season. Records and other historical evidence indicate that Finns built first wooden saunas in the 5th and 8th century [4].

Early saunas were dug into a hill or embankment. As tools and techniques advance, they were later above ground using wooden logs. Rocks were heated in a stone fireplace with a wood fire. The smoke from the fire filled the room as the air warmed.

Once the temperature reached desired levels, the smoke was allowed to clear and the user entered. In Finland Swimsuits, towel or any other garments is rarely worn in the sauna. Families often go to the sauna together which is not considered eccentric since family saunas are an old tradition. In these private saunas swimsuits or towel are never worn. In older times women also give birth in the sauna because it was warm and sterile environment. Eventually, the sauna evolved to use a metal wood stove with chimney. Air temperature around 70°C-80°C (160-180° F) but some times exceed 90° C (200° F) in a traditional Finnish sauna. Steam vapors were created by splashing water on the heated rock. The steam at high heat caused the bather to perspire, thus flushing away impurities and toxins from the body. The sauna was (and still) an important part of daily life and families bathed together in the home sauna. When the Finns migrated to other areas of the globe they brought their sauna design and tradition with them, introducing other cultures to the enjoyment and health benefit of sauna. This led to the further evolution of the sauna including the electric sauna stove: which

was introduced in the 1950's and far infrared sauna, under many circumstances, temperatures approaching and exceeding 100°C (212°F) would be completely intolerable. Saunas overcome this problem by controlling the humidity. The hottest Finns saunas have reactively low humidity levels in which steam is generated by pouring water on the hot stone. This allows air temperatures that boil water to be tolerated and even enjoyed for long periods of time. Other types of sauna, such as the hamman where the humidity approaches 100% will be set to a much lower temperature of around 40°C (104°F). As the technology advanced, many types of heaters (Room heaters) were developed; amongst them are Air heaters and Electric heaters. Air heaters are also of different types, as we have ceramic air heaters, cable air heaters, Duct air heaters, Flexible heaters, radiant air heaters and tubular air heaters [5].

Each type of air heater has its own unique features and Ideal application. Air heaters are heating devices, which use electricity to power themselves to create heat in the air. Air heaters are used to heat air in several domestic, commercial and industrial settings.

Air heaters can utilize a variety of method to move and transfer heat through the air, for example, ceramic air heaters use a layer of ceramic fiber insulation combined with a heating element to heat the air, while cable air heaters are formed from straight pieces of heating cable that are shaped into coils, spiral, sinuate star wound or other patterns.

Meanwhile, electric heaters are used to heat a variety of materials, in domestic, Commercial and industrial settings. Electric heaters can also be used to heat a specific area, shape or melt materials or even preserve the molten state of a substance; Electric water heaters are also available in unique sizes, shapes and heating configurations. An electric heater may heat from room temperature up to 1300°F (704°C) various grades alloys of metals are the materials of choice for heating element itself [5].

2.2 Theoretical Background

Electric heating is best explained by first understanding the concept of the term "heat". This is because, the primary aim of an electric heating is to convert electrical energy to a certain quantity of heat for the human usage. The heat generated is usually maintained at a particular temperature for a desired purpose. Therefore, let's look at some aspects of heat.

Heat: - Is a form of energy, and one of the valuable features of electricity, is the ease by which electrical energy can be converted into heat energy. There are two quantities of heat, which can be measured. They are: heat intensity (temperature) and quantity of heat.

Temperature: - Is the measure of the intensity of heat and is recorded in the lower ranges by thermometer. Pyrometers are used for higher temperature measurements. The common scale of temperature has been Fahrenheit ($^{\circ}\text{F}$) and centigrade [6].

$$\text{Temperature in degree Celsius} = (\text{Fahrenheit} - 32) \times 5/9 \dots\dots\dots 2.0$$

$$\text{Temperature in Fahrenheit} = 9/5 \text{ }^{\circ}\text{c} + 32 \dots\dots\dots 2.1$$

The name centigrade has been replaced by the name Celsius and 1 degree centigrade becomes 1 degree Celsius. The absolute scale of temperature is in Kelvin (K)

Quantity of Heat: Heat is a form of energy therefore; the same unit is used for quantity of heat as for other form of energy namely Joule.

Experimentally, heat required to raise temperature of 1kg of water is 4181J. Therefore, the quantity of heat required to raise temperature of a body is given by [6].

$$Q = C \times M \times t \dots\dots\dots 2.3$$

Where Q = quantity of heat in joule

- C = specific heat of the body
- M = mass of the body
- t = temperature rise in degree Celsius.

Quantity of heat is also measured in calorie. Calorie is the heat required to raise 1 gram of water by 1^oc.

Specific heat: the heat required to raise the temperature of a substance in joules.

Mass (kg) x temperature ^oc x specific heat of the material (J/ kg^oc) Different materials require different amount of heat to raise their temperature by 1^oc.

Heat transfer: A heated substance will give off heat to another substance at a lower temperature. Heat is transferred by conduction, convection and Radiation. Conduction takes place mostly in solids; convection takes place in liquid or fluids e.g. air while radiation takes place between mediums that are not physically connected to one another.

CONVERSION OF ELECTRICITY TO HEAT

When an electric current passes through a conductor the power spent in the conductor in watt is given by formula $p \text{ (Watt)} = VI$ 2.4

where V is the Voltage drop in the conductor and I is the current in amperes

From ohm's law $V=IR$ 2.5

Then, $P=I^2 R$ 2.6

where R is the resistance, of, the conductor in ohm's [7].

This energy is converted into heat, which raises temperature of the conductor. As the conductor gets hot, it gives off some of its heat to the surrounding atmosphere or substance. The higher the temperature of the conductor the faster it will give off heat.

HOME HEATING SYSTEMS

In the recent times various types of electric heaters are employed for an effective home heating. The Electric heaters are sometimes used in commercial places and some industries. Some electric heaters are listed below ---

1. Open type radiator or electrifiers
2. Convector heaters
3. Tubular Heaters
4. Panel Heaters
5. Electrically Heated hot-water radiator
6. Hot water and steam --- heating system
7. Floor -- Warming arrangement
8. Night storage Heaters

Now less consider the operation of at least two out of the list given above.

Convector heaters: - These consist of wound resistance element contained within a sheet --- metal case with inlet and outlet opening or louvers at the bottom and top respectively. The front and top may be of molded plastic material for the sake of pleasing appearance. These heaters may be either portable or fixed and may be handle with out fear of burnt. The action may easily be understood in reference to fig 2.1 below which shows the cold air entering the bottom of the heater, passing over the heater element and leaving the heater by the top opening as warm air.

A very satisfactory method of heating a room is to use convector heaters to warm to about 14°c together with a small radiant fire for local heating.

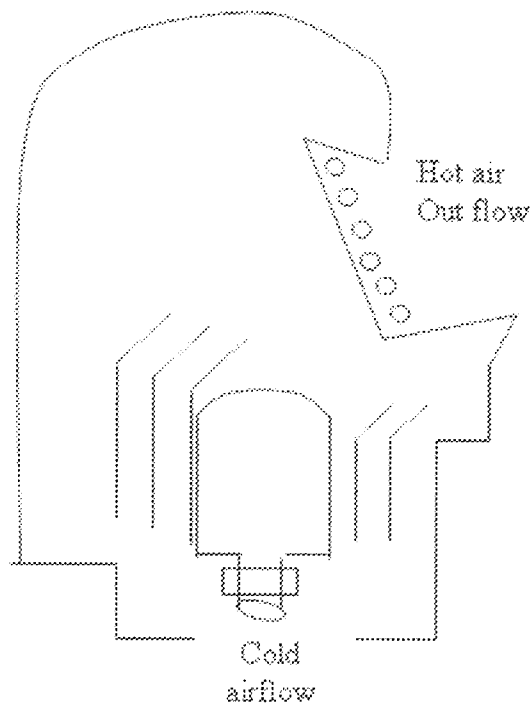

Fig 2.1 Convector heater

Electric Fires or radiators: Consist of spiral resistance wound on fire clay formers and working at a luminous temperature of 1400°c to 1600°c . About 50% to 60% of the heat emitted is in the form of radiant heat, while the remainder is spent warming, the air convection currents. The usual sizes are 60w to 3w be either portable or fixed.

BASIC MODES OF HEAT CONTROL

The two basic methods of heat control that are usually applied in most of the domestic heating appliance are:

- i. Simmer Start and
 - ii. The three-heat switch.
- i. **The simmer start:** Is used to control the temperature rise of heating element in oven, hot plates and bairers. It operates by regulating the current flow in ON-OFF step, thereby

controlling the amount of energy taken from the supply, which consequently regulates the heat generated.

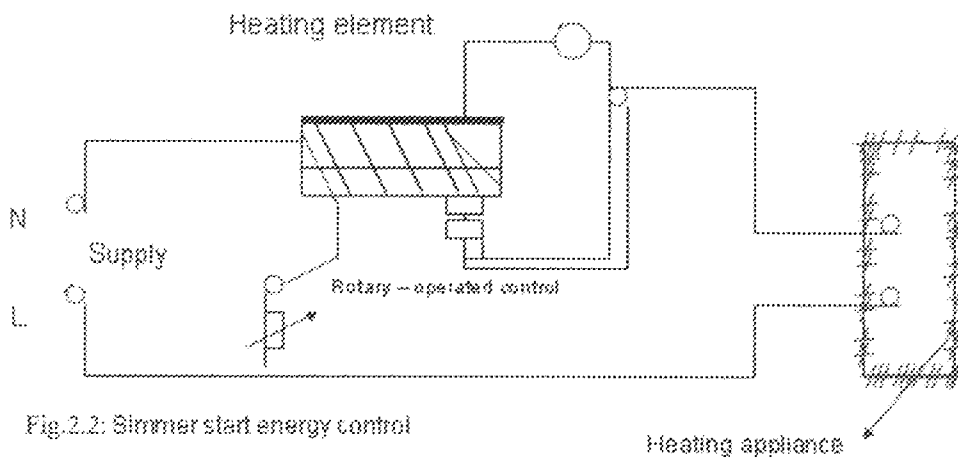

Fig.2.2: Simmer stat energy control

ii. **The three-heat switch:** - This device is employed to control the heating element of an appliance when it has two heating element circuits. For a low level of heat, the two elements are connected in series across the supply. For medium level heat only one element is connected in to circuit and for maximum heat level the two elements are connected in parallel the supply. The switching system is shown in the fig 2.3 below

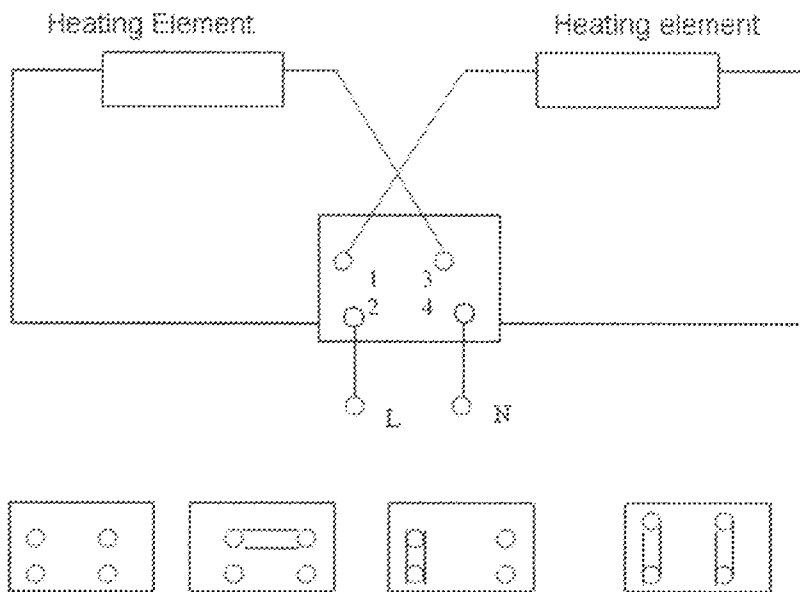

Fig2.3 switch contact position in three heat switch

EFFECT OF HEAT ON OTHER DEVICES

When an object is in contact with a heated material, the object usually has the same temperature rise, and is said to attain a thermal equilibrium [8]. Heat radiated from a heated material usually affects the atomic or molecular structure of the object that absorbed the heat. That is the reason why electronic devices are greatly affected by increase in temperature. When temperature of a semi conductor device is increased electrons move with a faster rate. This phenomenon usually causes a serious malfunctioning or total failure of the device [9]. Computers basically consist of about 99% of semi conductor devices and are usually provided with cooling fans. The fans are in- build within the CPU compartments. The fans takes away the hot air generated by the semiconductor device as result of continuous movement of electronic that brought about a dissipation of power in a form of heat. The cooling system employed helps to extend life span of the computers and at the same time improve efficiency.

Similarly, human bodies, hair and skins are usually affected when exposed to an extensive heat; temperature also has a serious effect on some medicines; food preservation and some chemical processes [10]. Therefore, design of the heating system of such sensitive places where these processes take place should be handled with high skill and expertise.

The electric room heater that is designed in this project is similar to convector heater and radiant fires that were explained earlier on. Although it differs in the aspects of control and distribution of hot air within the room. The two mentioned above use natural convection current of air to circulate hot air. They also use (in most cases) thermostat control for the temperature regulation. Where as the electric heater designed is to use fan for the distribution

of the hot air, semiconductor switch and sensor are also employed for an automatic temperature regulation.

CHAPTER THREE

DESIGN ANALYSIS

In this chapter a simple approach to be room heating circuit analysis was employed. It is intended to analyze the circuit as sub--systems presented below;

1. Power Supply Sub-Unit
2. Control circuit
3. Power switching Sub-Unit
4. Temperature Sensing Unit.

3.1 Power Supply Sub-Unit: - The power supply unit comprises of an a.c rectifier circuit that serves as the source of supply to both control and the monitory units. The rectified a.c. main is designed to produce 12V d.c supply using full-wave bridge rectifier. And from the diagram below it could be seen that D1 and D2 conduct on positive half cycle, while D3 and D4 conduct during the negative half cycle. Therefore, the rectified load current flows during both half cycles. D1 and D2 are forward biased, this produces a positive load voltage.

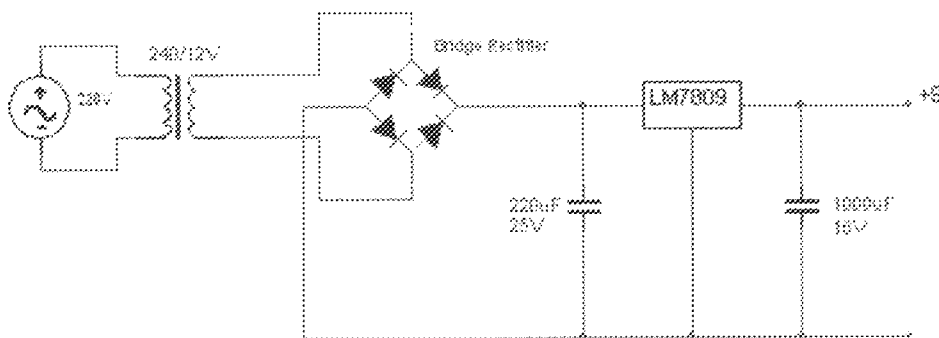

Fig. 3.1: Power Supply Unit

Mode of operation: - The 240v ac main was stepped down using 240/12v step down transformer and rectified with the help of the full wave bridge rectifier. A capacitor of 25v 2200 μ F was used to smoothen the d.c output voltage that has a.c ripples.

The r.m.s value of the induced e.m.f in the whole of the primary winding = (induced e.m.f/turns) \times number of primary turns

$$E_1 = 4.44f N_1 \Phi_m \dots\dots\dots 3.0$$

$$= 4.44 f N_1 I B_M A \dots\dots\dots 3.1$$

Similarly, rms value of the induced emf of the secondary is

$$E_2 = 4.44f N_2 \Phi_M A \dots\dots\dots 3.2$$

$$= 4.44f N_2 B_m A \dots\dots\dots 3.3$$

From equation (3.0) and (3.2) above we can have;

$$E_2 / E_1 = N_2 / N_1 = K \dots\dots\dots 3.4$$

Where K is a instant called voltage transformation ratio

From equation (3.0) if $N_2 < N_1$ i.e. $K < 1$ then transformation is known as step down transformer, as in the case of this project in which a step down transformer is used.

Also for an ideal transformer

$$\text{Input VA} = \text{output VA} \dots\dots\dots 3.5$$

$$v_1 I_1 = v_2 I_2 \text{ or } I_2 / I_1$$

$$V_1 / V_2 = 1/K \dots\dots\dots 3.6$$

In this design, a transformer with the following characteristics was employed.

- (i) Primary Voltage $V_P = 240v$
- (ii) Secondary Voltage $V_S = 12v$
- (iii) Secondary Current $I_S = 500mA$

Using the transformer formula $V_p / V_s = I_s / I_p$

Where the I_p is the primary current, it was found that

$$I_p = V_s I_s / V_p = 12 \times 500 / 240$$

$$= 25\text{mA}$$

This indicates that the transformer is a step down step with rating 240v, 25mA /12v, 500mA

$$\text{Also } I_{\text{peak}} = \sqrt{2} \times V_{\text{rms}} - 2 \quad (0.7) \quad \dots\dots\dots 3.7$$

$$= (\sqrt{2} \times 12) - 1.4$$

$$= 15.57\text{V}$$

$$\text{And } I_{\text{peak}} = \sqrt{2} \times I_{\text{rms}} \quad \dots\dots\dots 3.8$$

$$= \sqrt{2} \times 500\text{ma}$$

$$= 707\text{mA}$$

Rectification

The bridge with 2A rating was used in the design. It functions as an a.c to d.c.

Convectror. The d.c voltage can be calculated from

$$V_{dc} = \sqrt{2} V_{\text{peak}} / \pi \quad \dots\dots\dots 3.9$$

$$= (\sqrt{2} \times 15.57 / \pi) - 1.4$$

$$= 9.6$$

$$= 10.0\text{V}$$

$$\text{Where } \pi = 2.0\text{A}$$

Note that, the above values are available only at an input A.c of 240v A.c

Filtration

A high value capacitor chooses to eliminate the ripples. The value was 25V, 2200 μ F and the output voltage across it could be calculated as follows.

$$V_L = V_{\text{peak}} - V_{\text{diode}} - 0.5V_{\text{ripple}}$$

Where V_L is the load Voltage. If apple voltage is taken to be 3.2V the

$$\begin{aligned} V_L &= 16.97 - 2(0.7) - 0.5(3.2) \\ &= 13.97V \end{aligned}$$

3.2 CONTROL CIRCUIT

The control sub-Unit consist of a ramp generator, pwm generator, NPN transistor (C9014)and an op to - traic (Moc 3023) these components are connected together to form the control circuit that will regulated the gate current to the external triac (BT138).The details of how this sub-Unit functions to achieve the desired control is presented as follows;

Ramp Generator

The ramp generator was designed around NE555 multivibrator chip; and it was connected in an astable mode. A capacitor chip C_T connected between terminal 6,2and (0_v) or ground, produces a varying voltage that varies between $1/3 V_{cc}$ and $2/3 V_{cc}^{[10]}$. The output of the ramp generator is now fed to the pulse width modulator (pwm generator) .

The voltage across the capacitor varies exponentially between $1/3V_{cc}$ and $2/3V_{cc}$.

Therefore, a V_{cc} of 12V will produce V_c of.

$$\begin{aligned} V_c (\text{min}) &= 12 \times 1/3 \\ &= 4.0V \end{aligned}$$

$$\begin{aligned} \text{While, a } V_c(\text{max}) &= \frac{2}{3} \times V_{cc} \\ V_c(\text{max}) &= \frac{2}{3} \times 12 \\ &= 8.0\text{v} \end{aligned}$$

The minimum and maximum values of the capacitor voltages are utilized to provide zero and 100% power delivery to the heating element

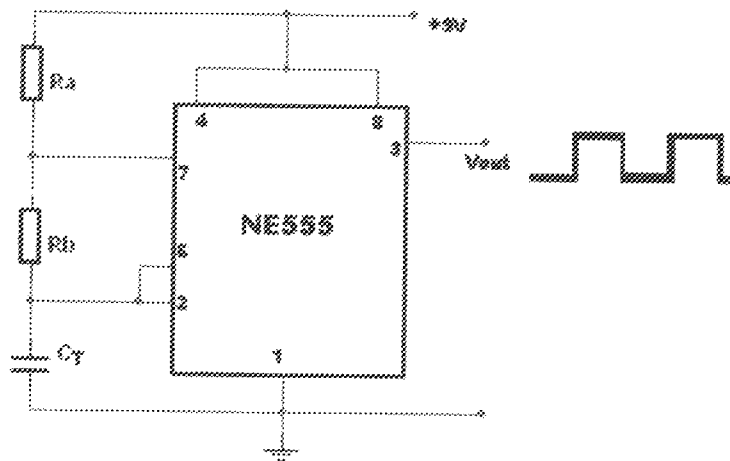

Fig 3.2 Astable vibrator

- RA = Resistance between pin 7 and Vcc
- RB = Resistance between pin 7 and (6,2)
- CT = Timing capacitor connected between pin (6, 2) and 0v

A frequency of 10kHz was chosen for square wave output to develop power in the heating element. Resistor RA was also chosen to be 1k and RB was made to vary or variable. The value of CT was selected to be 0.47 μF Capacitor, so that, whenever, RB is varied, the output frequency of the ramp generator will also vary corresponding

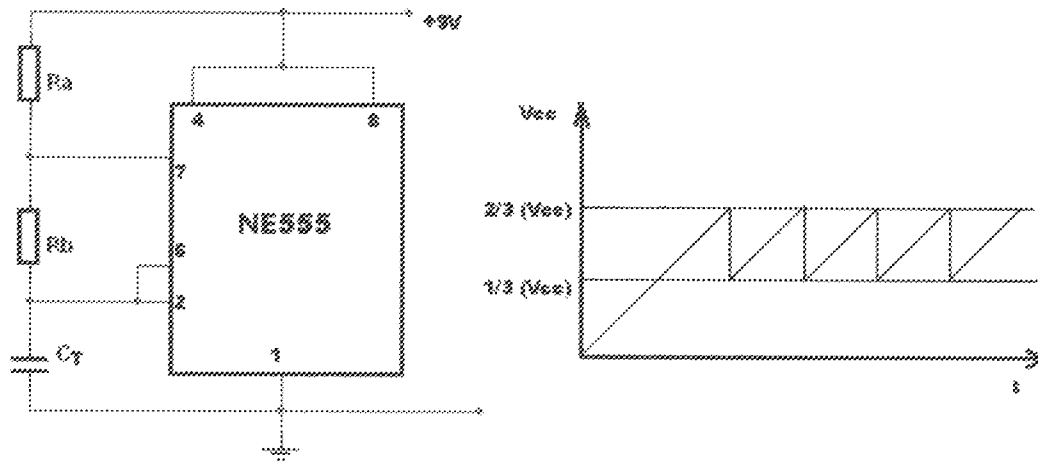

Fig 3.3 Ramp generator

Pulse width modulation generator

The pulse wave form (pwm) generator accepts two inputs and produces a pulse width modulated output that controls a high power solid-state triac (BT138). The output of the ramp generator is amplified and passed through an inverting input of the D.C Comparator. The comparator's second input is from the D.C reference divider network

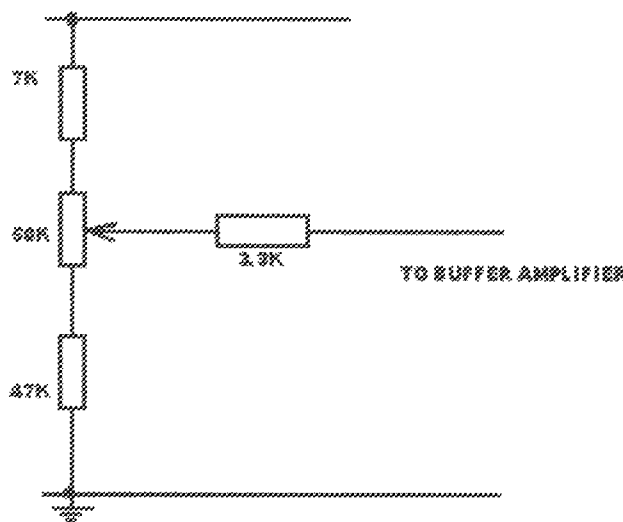

FIGURE 3.4 Potential Divider Network.

The setting that gives 3.93 and 8.1 are to match with that of capacitor voltage explained earlier on

DC Comparator

A. d.c comparator is a high gain d.c amplifier; and because of its high gain, the output gets saturated for a very small differential between its two inputs. Thus,

If an input voltage V_1 greater than the second input voltage V_2 then out put voltage (V_o) will be high.

$$V_1 > V_2; V_o = \text{high}$$

Whereas, when the input voltage v_1 is less than the reference voltage V_2 , the output voltage (V_o) of the d.c comparator becomes low.

$$V_1 < V_2; V_o = \text{low}$$

Hence, at this point the capacitor voltage is compared with d.c reference voltage and the comparator's output goes high or low depending whether V_1 is higher than V_2 or Vice Verse.

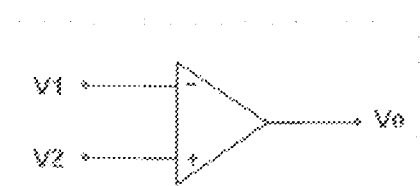

Fig.3.5 D.C Comparator

Similarly, the output of this divider network is regulated through the setting of the potentiometer. The output also, is in the range of $1/3 V_{cc}$ (minimum) and $2/3 V_{cc}$ (maximum). In other words, the divider network provides a d.c reference voltage to the comparator. For example, when the potentiometer's setting is at position a the output voltage will be:

$$\begin{aligned}
 V_{out} &= \frac{V_{cc} \times (R_a + R_b)}{R_a + R_b + R_c} \dots\dots\dots 3.10 \\
 &= \frac{12 \times 97}{144} \\
 &= 8.1V
 \end{aligned}$$

Whereas, when the setting is at position B,

$$\begin{aligned}
 V_{out} &= \frac{12 \times R_b}{144} \\
 &= 3.93V
 \end{aligned}$$

Note that, the potentiometer has a wiper that can be set to position A or B any other position in between the two

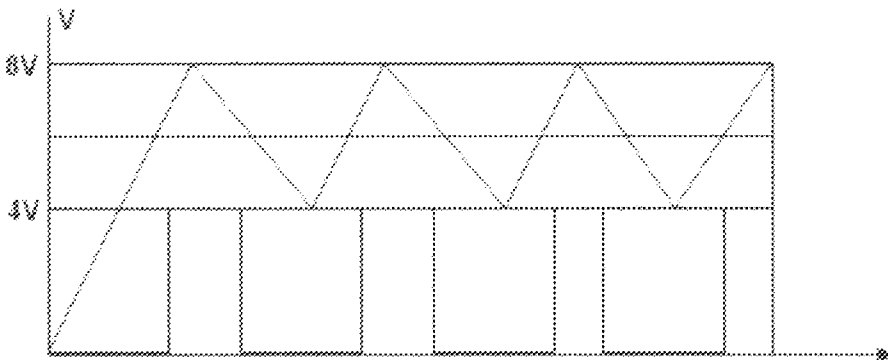

Fig. 3.7 output of the pulse wave generator

By altering the value of the d.c reference voltage, the duty cycle of the pwm wave form is regulated from zero percent (0%) to hundred percent (100%). By so doing, the pulse

wave form generator's output drives an NPN transistor that switches an opto – triac (MOC 3023) “ON” and “OFF”

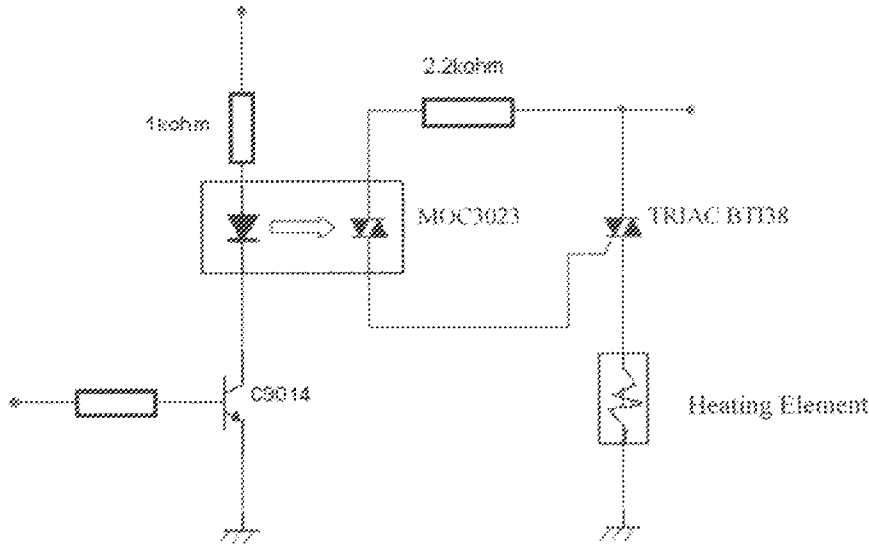

Fig 3.8 Solid-State Switch Opto – Triac Controlled By NPN Transistor

From the data sheet the collector current of NPN C9104 Transistor was obtained as I_c

$$= 12\text{mA}$$

The D.C Current gain β was also found to be equal to 300 i.e. $\beta = 300$

Thus, from the relation $I_c = \beta I_b$

$$\text{and } R_b = \frac{V_b - V_{be}}{I_b} \dots\dots\dots 3.11$$

Value of the base drive of the NPN transistor can be calculated as follows;

$$I_c = \beta I_b$$

$$12 \times 10^{-2} = 300 \times I_b$$

$$\begin{aligned}
 I &= (12 \times 10^{-2})/300 \\
 &= \frac{12 \times 10^{-2}}{3 \times 10^{-2}} \\
 &= 0.4 \times 10^{-4} \\
 R_b &= \frac{V_b - V_{be}}{I_b} \dots\dots\dots 3.12 \\
 &= \frac{12 - 0.9}{40 \times 10^{-6}} \\
 &= \frac{11.1}{40 \times 10^{-6}} \\
 &= 0.2773 \times 10^6 \\
 &= 280\text{k}\Omega
 \end{aligned}$$

Note that, during Construction it was discovered that this value of resistance barely switched the LED "ON" therefore, it was reduced to just 3.3kΩ. This value was chosen to simply yield a good switching characteristic.

3.3 SWITCHING CIRCUIT

The switching circuit basically deals with the operation of the opto – triac relative to that of the LED that was incorporated to its package. It also deals with the ability of the opto triac to switch or Isolate other external triac.

MOC 3023 opto – triac is usually employed for an electrical Isolation between the high voltage side 240 A.c and low Voltage side 12V d.c as mentioned earlier, this device is incorporated with an integral LED. When the LED turns “ON” a forward current flows and the opto triac is triggered into an active state. As the opto – triac turns “ON” a gate current is sent to the external triac BT 138 which also switches “ON” the external load or the heating element.

The “ON” and “OFF” time of the LED is determined by the duty cycle of the pulse wave form (PWM) drive. Ie the higher the duty cycle, the longer the “ON” time will be. Usually the internal LED requires a forward current of about 15 mA at forward current of about 1.7V. As the external triac becomes active the heating element becomes “ON” too: depending on the length of the “ON” time of LED/opto – triac. The process is repeated on and on, until the room temperature raises to a value close to the preset value; hence the sensor sends in signal to cut off the supply to the external triac via an opto triac; which invariably turns “OFF” the heating element.. The heating element is connected in series with the external triac BT138 so as to enable the design temperature ranges be achieved.

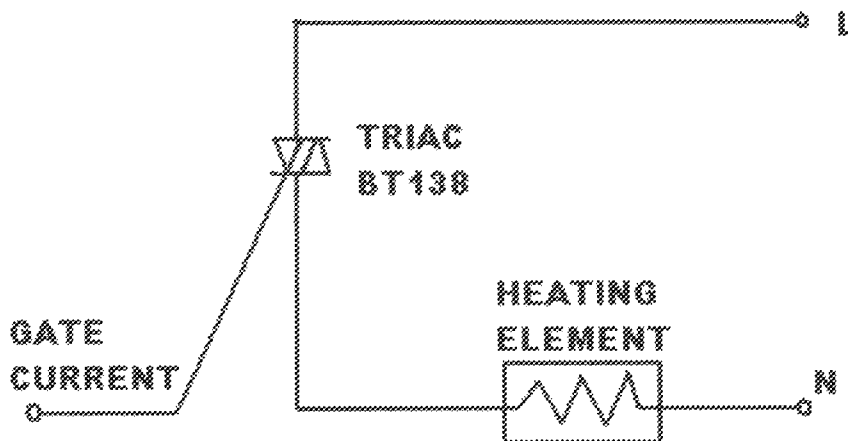

Fig. 3.9 Extend triac BT138 controlling the heating element

3.4 A POWER DEVELOPED IN THE HEATING ELEMENT

The power developed in the heating element can be expressed as follows.

$$P = \frac{V^2}{R} \dots\dots\dots 3.13$$

$$R = \frac{V^2}{P} \dots\dots\dots 3.14$$

Introducing t

The Energy consumed by the heating element is given by

$$E = I^2 R t \text{ (Kwh)} \dots\dots\dots 3.15$$

$$\text{Where } t = \frac{t_{on}}{T_{on} + t_{off}} \dots\dots\dots 3.16$$

$$E = \frac{I^2 R t_{on}}{T_{on} + t_{off}}$$

$$= I^2 R (t_{on} / T)$$

Therefore, by regulating the t_{on} Via the D.c reference circuit, power developed in the heating element is thereby altered or controlled.

3.4 TEMPERATURE SENSING SUB-UNIT

This sub unit consists of an integrated circuit temperature sensor (LM35), an operational amplifier and a transistor switch. The circuit diagram for the sensing sub unit is depicted below.

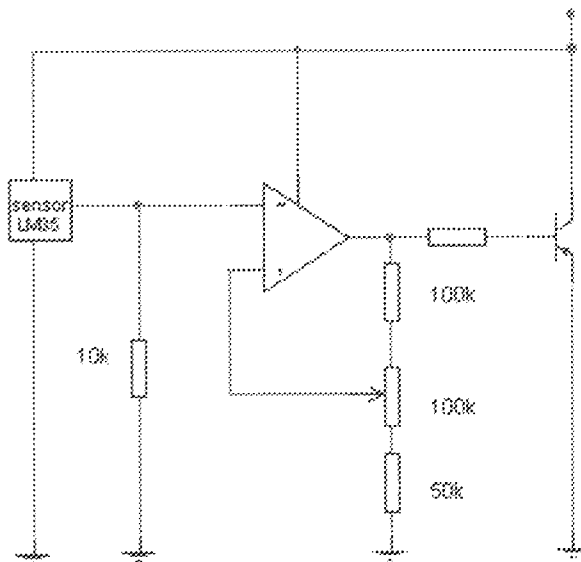

Fig3.10 temperature sensing sub unit

The LM35 is an IC sensor that can reliably measure temperature in the range of 0°C – 100 °C. It produces an output of 10mv/°C. The sensor output is amplified via amplifier a₄ that has an adjustable gain factor. However, the maximum rooms temperature was fixed at 45°C and the minimum at about 23°C

This temperature range can be obtained by setting $V_o = 0.7$

$$0.7 = V_{in} \times A_v \dots\dots\dots 3.17$$

A_v was made variable between

$$\frac{(100K + 1)}{150} \text{ and } \frac{(100 + 1)}{5}$$

That is, between 1.66 and 3

These values corresponds to a V_{in} of $\frac{0.7}{3}$ to $\frac{0.7}{1.66v}$

$$\frac{0.7}{3} = 0.233\text{v at } 23.3^{\circ}\text{c}$$

$$\frac{0.7}{1.66} = 0.44 \text{ at } 44^{\circ}\text{c}$$

Over Temperature Detector

When the room temperature rises above the desired level. Q2 turn "ON" and Q1 is forced to be "OFF" thus. the power develops in the heating element is now switched "OFF" regardless of the pwm generator's output. The heating element will remain in an "OFF" position until Q2 goes "OFF" and Q1 switch "ON" again, depending on the temperature level of the room under consideration.

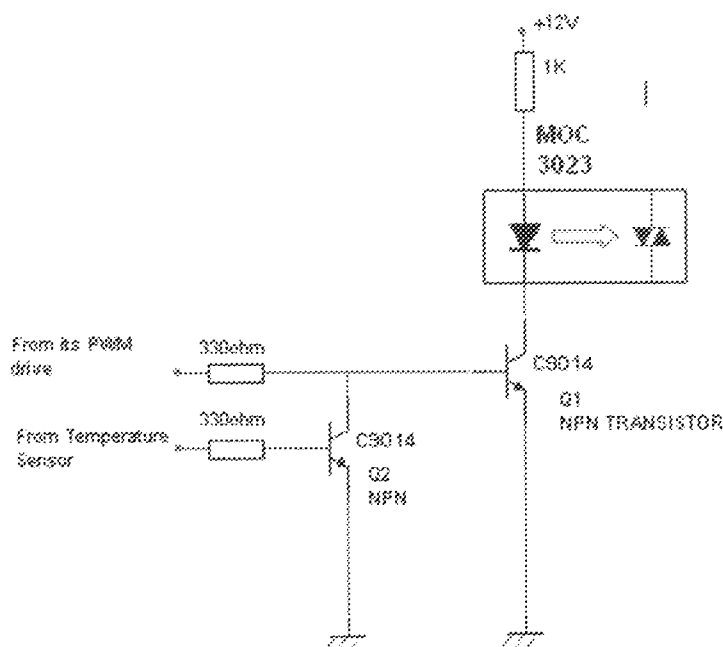

Figure 3.11 Over-Temperature Detector

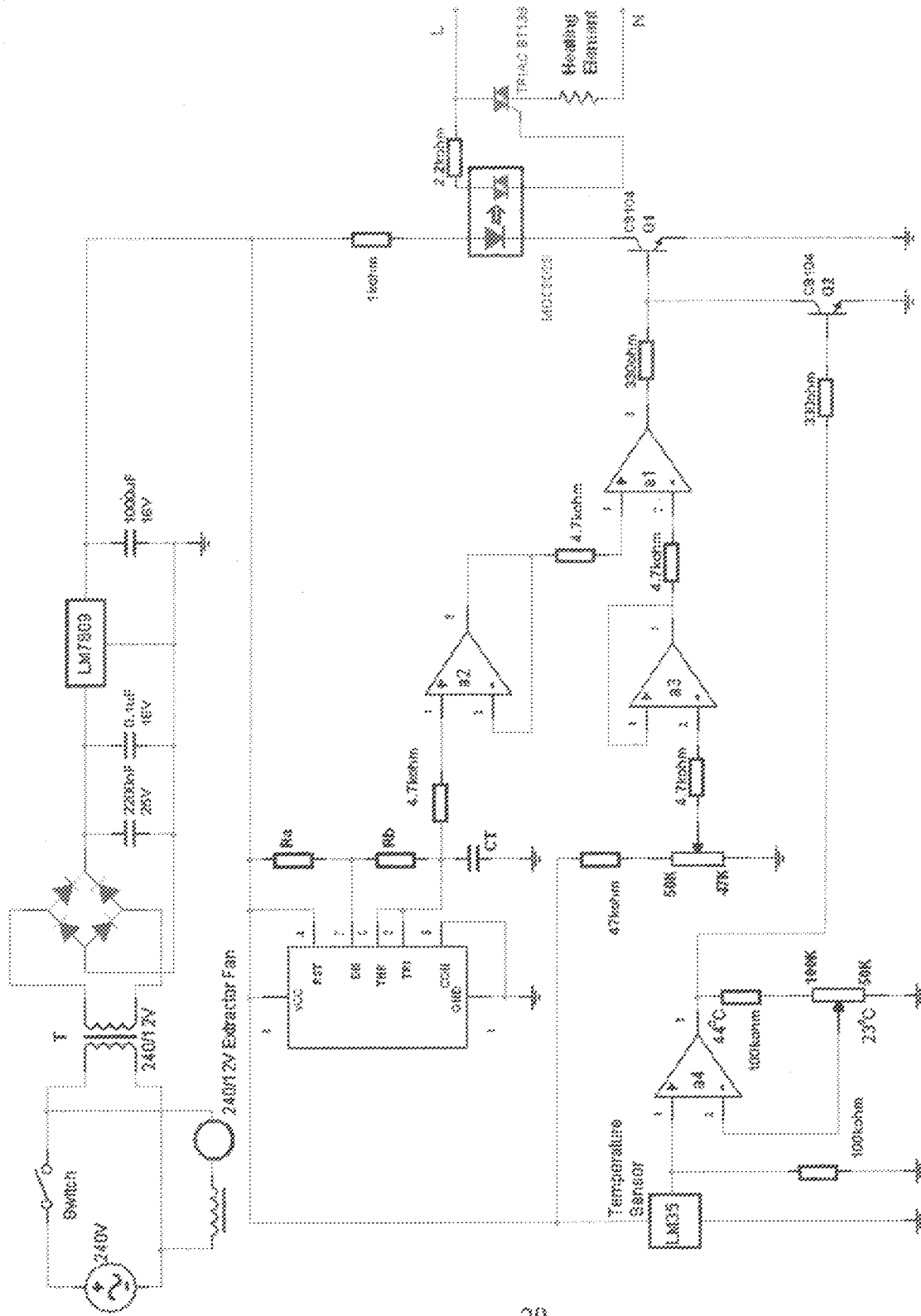

Fig. 3.12: Circuit Diagram for an Adjustable Electric Room Heater

CHAPTER FOUR

CONSTRUCTION AND TESTING

This chapter emphasizes on the construction of the project, component used in the construction processes and method adapted for testing the circuits operation.

4.1 LIST OF COMPONENTS

Table 4.1 lists of components

COMPONENTS	VALUES	NUMBER
Resistors	1k, 2.2k, 3.3, 4.7, 47k 50k, 100k, and 300k	1,1,1, 3,2,2, 1, and 2, respectively
Variable Resistors	50k and 100k	1,1
Transistors	C 9104	2
Capacitors	0.1 μ F, 22 μ F, 1000 μ F	2,1,1
Voltage regulator	LM7805	1
Bridge rectifier	200v/2A	1
Sensor	Lm 35	1
Triac	BT 138	1
Opto –Triac	MDC3023	1
Op- amps	LM 324	1
Transformer	240/12V	1
Heating element	1.5kw	1
Extractor Fan	240V/12A	1

4.2 CONSTRUCTION

Under this sub-section the components lay out, coupling and construction of casing (wooden casing) will be discussed.

The lay out of the circuit was done with maximum spacing in mind and many techniques of circuit lay out were considered and the best was choosen, that is, the use of Vero board.

The Vero board consists of two sides, the plan side and the reverse side that has parallel copper strips pasted to it. Also equal spaced holes are perforated from the plan plastic side pass the copper strips. Components are lay on the plan side and their leads passed to the reverse side through the holes for soldering to the copper strips.

Mounting of Components was accomplished by making reference to the circuit diagram. However, before mounting, each Component's terminals and functionality are verified. When mounting, Components, for the power supply – sub unit are first assembled and soldered and its required output in confirmed. Eight (8) pins IC sockets are soldered on to the Vero Board as to accommodate the NE 555 Timer the sensor Lm 35, and op-amps (Lm 324)

40w earth soldering Iron and Very short Jumper wires were used. Precision soldering was carried as to avoid short circuit of Components.

This is achieved by the use of pointed pen soldering Iron with Little Lead

For the maximum safety of operation, a wooden casing was employed. The extractor fan was mounted on a horizontal wooden bar of about 28 cm length. The heating element was fixed on rectangular wooden casing that is holding the wooden bar. This casing of 30 cm x 12cm x 30cm was intended to hold the heating elements, the fan and the whole circuit. The second casing is designed to cover the heating compartment.

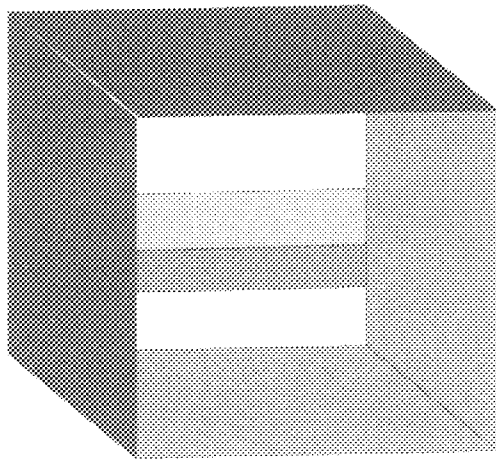

i) Wooden Frame

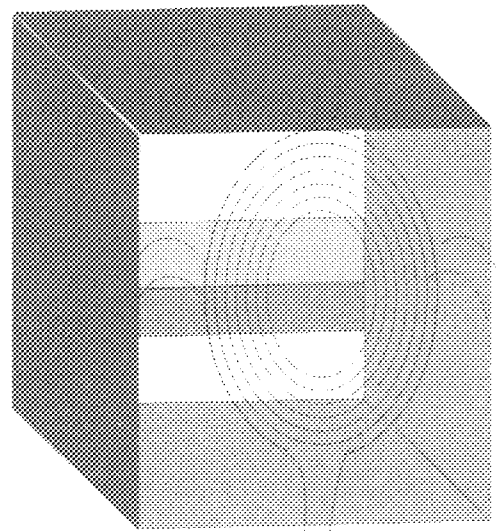

ii) Mounting of the Heating Element

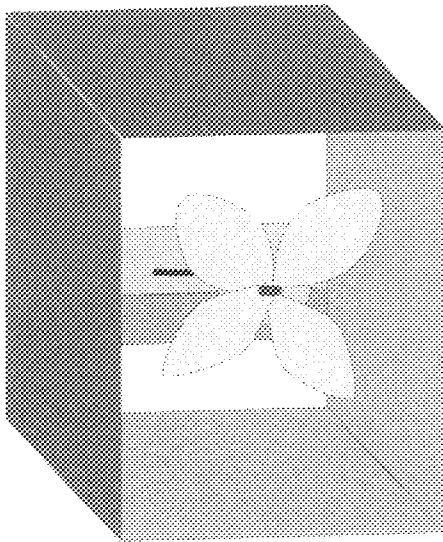

iii) Mounting of Extractor Fan

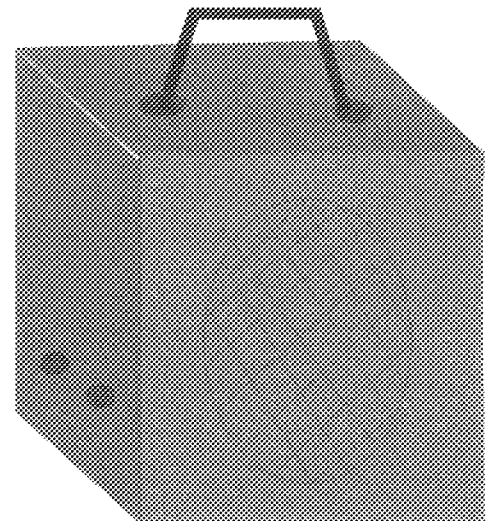

iv) Complete Heating Compartment

4.3 PRINCIPLE OF OPERATION

The heating element is powered by 240V 50Hz A.C supply. Both the control and sensing circuit use +12V D.C to trigger most of the major Components, such as: sensor, ramp generator and other op-amps. 12V D.C was the output of the power supply sub-unit. The control circuit is made up of a

ramp generator, pwm generator and NPN C9104 transistor (Q1). Also the ramp generator produces a ramp signal or a saw like signal that was passed through the pwm generator. The pwm generator is essentially a comparator NE555. It compares the output of the ramp generator to D.C reference voltage from the potentiometer network. As the output of the ramp generator approaches the D.C reference voltage the output of the comparator goes high and NPN transistor C9104 Q₁ is turn "ON" which also switches an opto triac MDC3023 "ON" as this condition is established, a gate current is now send to the external triac BT 138 that switches "ON" the heating element.

As the temperature tends to exceed the present limit, the sensor (LM35) sends signal via NPN Transistor (Q2) that force Q₁ "OFF" in respective of the output of the pwm generator. This action switches "OFF" the heating element. As the temperature drops Q₁ turns "ON" and the heating element is "ON" again.

The "ON" and "OFF" time of the comparator can be varied by regulating the frequency of the reference voltage. For this project a frequency of 10KHz was choosen.

4.4 TESTING

The circuit was first tested on the breadboard and was confirmed functioning satisfactory. It was however observed that the value of the NPN base resistor calculated was too high, so a value of 3.3k was chosen as to enable the L.E.D switch "ON". The circuit was tested for the second time after being mounted onto the compartment and the same result was obtained. When the room temperature attain a particular level or close to preset level the sensor action was observed cutting off supply to the heating element. Similarly, as the temperature drops below the preset limit the heating element was "ON" again. For a close monitoring, a minimum-preset value of 23^oc was selected.

4.5 PROBLEMS ENCOUNTERED

During the construction of this project, some problems were encountered and they include the problem of obtaining the exact rating of the heating element that is, 1.5kw. This is because, most of the ones available in the market are 1kw and below. Another problem was the construction of casing, instead of metal one. The wooden type was employed for maximum safety. Aluminum Sheets were placed internally to the second casing(in a form of lagging) to avoid direct heating of the plywood forming the second casing.

CHAPTER FIVE

5.1 RECOMMENDATION

- i. For subsequent work on this project, amore standard, safe and elegant casing may be constructed to portably housed the heating compartment.
- ii. This design is only restricted to a portable room heater, however, if the capacity of 1.5kw rating must be exceeded then, the control circuit will have to be modified.
- iii. Also a temperature display unit should be incorporated for an accurate temperature setting.

5.2 CONCLUSION

The system satisfied the expected mode of operation. The temperature sensor LM35 has satisfactorily accommodated temperature ranges up to 45^oc and above. Thus allow for an effective control of the room temperature.

REFERENCES

- [1] WWW.A.B.C.Com Weatherforecast (Nigeria)
- [2] T.G. Francis (1971) Electrical Installation Work Long man London pg.-183
- [3] Musa Abdulrazaq Danjuma project work on electric Room heat using Thermostats control. FUT Minna (2003), pg. 5-9.
- [4] www.wikipedia.org/wiki/isauna History on room heaters
- [5] www.geindus.googlepages.com/heater
- [6] T.G. Francis (1971) Electrical Installation Work Long man London pg.-181-182
- [7] Engr. Dr. Oria Usifo Electrical Networks Design and Installation in Buildings, pg. 140-143 and pg 157-158
- [8] Young FreedMan (1988) University physics, Extended version with modern physics (ninth edition)
- [9] USIFOH OBIAJURE.E Design and Construction of heat monitoring device pg. 6-11
- [10] www.technologystudent.com Article on effect of heat
- [11] www.datasheet4u.com configuration of astable mode multi-vibrator.

APPENDIX

Adjustable electrical room heater (1.5KW) operational manual

- The device is powered by 240V/50Hz A.C supply.
- Always switch "OFF" the device when not in use.
- It operates in the temperature range of $23^{\circ}\text{C} - 45^{\circ}\text{C}$
- Temperature rise approaches the preset limit the device is switched "OFF."
- As the temperature drops below the preset limit, the device is switched "ON."
- For a normal operation, the length of "ON" time is set at 50%.
- When the setting is at minimum, the device will not switch "ON."
- Two knobs are provided, the upper knob for setting the length of "ON-OFF" time and the second for temperature selection.
- Heater not coming "ON" check.
 - i) The Supply Voltage
 - ii) Room Temperature
 - iii) Time Setting (possibly at minimum level)
 - iv) Plug fuse need to be replaced.