

DESIGN AND CONSTRUCTION OF AN AUTOMATIC POWER CHANGE-OVER

BY

IBU EDWIN ADOGA

2000/9838EE

**DEPARTMENT OF ELECTRICAL AND COMPUTER
ENGINEERING**

OCTOBER 2006.

DESIGN AND CONSTRUCTION OF AN AUTOMATIC POWER CHANGE-OVER

IBU EDWIN ADOGA
REG NO 2000/9838EE

A THESIS SUBMITTED TO THE
DEPARTMENT OF ELECTRICAL AND
COMPUTER ENGINEERING, FEDERAL
UNIVERSITY OF TECHNOLOGY MINNA

OCTOBER 2006

DEDICATION

I wish to dedicate this work to God almighty the most merciful and faithful for keeping me alive to complete my work.

DECLARATION

I, IBU EDWIN ADOGA, declare that this work was done by me and has never been presented elsewhere for the award of degree. I also relinquish the copyright to the federal university of technology, Minna.

IBU EDWIN ADOGA

NAME OF STUDENT

Edwin 11/10/06

SIGN\DATE

ENGR. J.G. KOLO

SUPERVISOR

J.G. Kolo 11/10/06

SIGN\DATE

ENGR. M.D. ABDULLAHI

(H.O.D)

SIGN\DATE

EXTERNAL EXAMINER

SIGN\DATE

ACKNOWLEDGEMENT

I want to give thanks to God who has given me the privilege to be alive till now. I want to express gratitude to my supervisor Engr. J. G. Kolo, thank you for your constrictive criticism.

I want to thank my loving parents Hon. Mr. & Mrs. J.E Ibu for having faith in me to succeed; I would have been nothing if not for your love and may God bless you and keep you to reap from your labor.

As for my family members, I cannot thank you enough for the courage you have in me, may God bless you all for your efforts towards my well being.

To all my friends, who have stood by in times of difficulty, may God give you all the wisdom to be the best in your generation.

And to all those that have contributed to my success directly or indirectly I thank you and also wish God will reward you justly.

ABSTRACT

Power failure or outage in general does not promote development to public and private sector. The investors do not feel secure to come into a country with constant or frequent failure. So these limits the development of industries. There are processes that can't be interrupted because of its importance, for instance surgery operation in hospitals, transfer of money between banks or transfer of important data and lots more.

Therefore, there is every need to prevent such inconveniences that is why devices such as power change-over were invented. Power change-over existing before were manually controlled.

Bearing this in mind, the project was designed to automatically change or switch power supply between an auxiliary power source and the main source. This is achieved by the use of integrated circuits that have timing abilities. The uses of relays are also incorporated to effect the switching. The process also is powered by a battery which will supply voltages or pulses to the integrated circuit.

The project eliminates the stress of switching on the auxiliary power supply manually. This is a good point as some auxiliary power supplies are located far away. The device is meant to be indoor to prevent damage to the components because the are non-water resistant

TABLE OF CONTENTS

TITLE PAGE.....	i
DEDICATION.....	ii
DECLARATION.....	iii
ACKNOWLEDGEMENT.....	iv
ABSTRACT.....	v
INTRODUCTION.....	1
1.1 AIMS AND OBJECTIVE.....	1
1.2 METHODOLOGY.....	2
1.3 LIMITATION OF THE PROJECT.....	3
CHAPTER TWO: LITERATURE REVIEW.....	4
2.1 HISTORICAL BACKGROUND.....	4
2.2 THEORETICAL BACKGROUND.....	6
2.3 GENERAL DESCRIPTION OF POWER SUPPLY.....	7
2.4 ELECTRICAL POWER SUPPLIES.....	8
CHAPTER THREE:	
3.1 DESIGN AND IMPLEMENTATION.....	9
3.1.1 POWER SUPPLY 1.....	10
3.1.2 POWER SUPPLY 2.....	11
3.1.3 CONTROL LOGIC UNIT.....	12
3.1.4 MOTOR TERMINAL.....	15
3.1.5 OUTPUT LOAD.....	15
3.2. OPERATING PRINCIPLE OF THE CIRCUIT.....	16

3.3 RELAY SWITCHING UNIT.....	17
3.4 TRANSISTOR.....	18
3.5 CIRCUIT CONSTRUCTION.....	20
3.6 CASING CONSTRUCTION.....	21

CHAPTER FOUR: TESTING AND DISCUSSION OF RESULTS

4.1 TESTING.....	23
4.2 RESULT AND DISCUSSION.....	26
4.2.1 FIRST STEP.....	26
4.2.2 SECOND STEP.....	26
4.2.3 THIRD STEP.....	26
4.2.4 FOURTH STEP.....	26
4.3 DISCUSSION OF RESULT.....	27
4.3.1 TROUBLESHOOTING.....	28

CHAPTER FIVE: CONCLUSION AND RECOMMENDATION.....

5.1 CONCLUSION.....	29
5.2 RECOMMENDATION.....	30
REFERENCES.....	31

LIST OF FIGURES

1. **Fig.2.1 block diagram of the circuit**
2. **Fig. 3.1 block diagram of respective units**
3. **Fig 3.2 power supply 1**
4. **Fig 3.3 power supply 2**
5. **Fig 3.4 the normal RC mode of 4060B showing its pin configuration**
6. **Fig. 3.5 the internal circuit of 4013B**
7. **Fig 3.6 the D-type latch at SR mode**
8. **Fig.3.7 relay switching unit**
9. **Fig. 3.8 a 25C945 NPN transistor showing its pin configuration**
10. **Fig.3.9 the dimension of wooden platform**
11. **Fig. 3.10 the dimension of circuits casing**
12. **Fig 3.11 circuit diagram of project**
13. **Fig.4.1 control box**

LIST OF TABLES

1 table 3.1 truth table of 4013B

CHAPTER ONE

INTRODUCTION

The project is designed for power supply application. It involves automatic change-over between the main power supply and an auxiliary power supply such as a generator. The project implements an automatic switching or starting of the power generator whenever the main power fails. The circuit of the project consists of logical control unit and relay switches.

The design of the project takes into consideration, practical or real life situations, even though it is a prototype design. Irrespective of that fact, a lot of precautions were put in place to make its performance acceptable.

The basic operation of the project is to switch on an auxiliary power supply (like a generator). This operation connects the power supply from the generator to the load after a predetermined time interval. This is intended to normalize the current from the generator. This switching is mainly possible through the use of the relays.

The device was designed to automatically interchange power supply moments after the A.C mains are restored and to switch off the generator. At this point the device is powered by a battery. The device removes the stress of switching on the generator when power failure occurs

1.1 AIMS AND OBJECTIVES

The project is aimed at designing and construction of an automatic change-over switch. The device functions by changing over or switching power between the A.C mains and the auxiliary power supplies.

1.2 METHODOLOGY

The operation of the power unit was well organized and coordinated for an efficient performance. The operational process is outlined below;

- (i) The power circuit is not active when there is A.C mains supply
- (ii) Its response to power failure is by switching on the starting mechanism of the generator.
- (iii) There is a delay in the loading of the generator so as to attain stability for a while. After this the generator is loaded.
- (iv) Power supply from the generator is interchanged the moment the A.C mains are restored. Immediately after this the generator is switched off.
- (v) While the unit is inactive, the battery is charged by the A.C mains to prevent failure.

The circuit contains some integrated circuits(IC) more especially the CMOS (complimentary metallic oxide silicon) type. The CMOS consumes less power from the battery. That is why it was incorporated into the circuit. The circuit also consists of relays that provide external switching. These devices are quite robust for efficiency and reliability.

1.3 LIMITATIONS OF THE PROJECT

Because the project is a prototype its loading capacity is limited, this is so because of the relays implemented. It is also limited to a one phase supply. For device to be functional the generator has to be in good working condition. If the generator has a starting problem the device will not operate.

CHAPTER TWO

LITERATURE REVIEW

2.1 HISTORIC BACKGROUND

It is wise to provide a building with an auxiliary power supply as an alternative to the main power supply; this is so because the main supply could fail. Most buildings have stand by power supply such as a gasoline or diesel generator and power inverters to that effect. Most developed nations have uninterruptible power supply but in the developing countries there is power failure or power outage. As such, a country like Nigeria is accustomed to unstable power supply.

Most developed countries have huge facilities that provide electricity. These generate substantial amount of electricity for consumers and industries through gas, nuclear, solar technologies. On the contrary, Nigeria's power generation is based mainly on the hydroelectric dams which has proven not be substantial for the consumers. As a result the overall load is greater than the available power, this leads to constant or frequent power outage or load shedding

Electricity is significance to the everyday activities thereby people turn to auxiliary generators due to unstable power in the country. The availability is a problem on its own talk less of its stability. Consumers still connect their appliances to the mains because the costs of maintaining the generators are quite expensive.

The importance of an automatic change over unit is the interchanging from one source to the other independent of the user's manual. This process is automated and manual enhancements are incorporated to the device in case of emergency.

Generally, power change over are sometimes inclusive of the building's electric wirings. One of the known contributors to electricity was Benjamin Franklin who proved lightning is electricity and invented the lightning rod in 1752[2]. George Ohm who postulated the Ohms law($V=IR$)[4]. Also, Henry Rowland that invented the first electric machine. The development of a bulb in 1879 by Thomas Edison [2]. He also established the first commercial power plant in 1881[2]. The first standardization of commercial electricity supply was made in 1897 known as the first electric code [3]. The first successful hydropower project was in the Niagara Falls in the U.S.A [2].

As early as the beginning of the twentieth century, different companies in the U.S.A started manufacturing and development of electric building wiring devices. Such as the Cutter manufacturing company located in Philadelphia and the National Electric Company (NEC). They produced electric elements such as circuit breakers, fuse boxes, conduit wires, power changers and lots more [3]. Their technologies were based on modern electronic controls.

In 1975, Kon doh and Toyoshi from Japan patented a unique change over type loading assembly which was designed for non utility power generators. They were installed in high rise buildings or other facilities in order to deal with situations such as power failure [3]. This invention was concerned with a loading device assembly for dry type testing equipment in which series of resistors made of metal member used for testing purposes without regard to water resistance. The invention was quite significant but it did not employ advantages of modern electronics

2.1 THEORITICAL BACKGROUND.

The main feature of this project is the electronic control. The control allows power to be automatically switched from the main power supply line to generator supply line. The generator is also controlled by the device i.e. the starting of the generator.

After the generator is switched on, it remains in that condition without connection to the load. This is to prevent damage to the alternator(s) of the generator. Alternators have to attain a steady state status before loading is done.

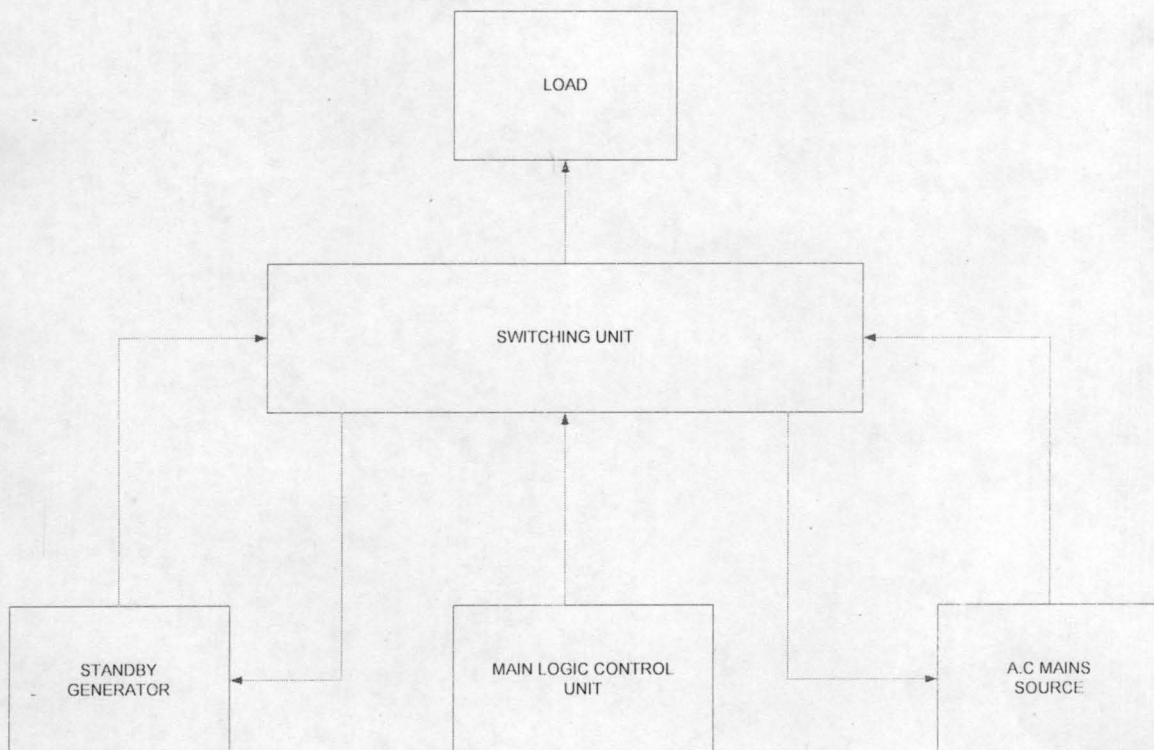

Fig 2.1 block diagram of the respective units

Figure 2.1 shows the block diagram of the project showing the load, the switching unit, stand-by generator, main logic control unit and the A.C source. The main part of the

and timing operations [5]. The type of the integrated circuit in use is the CMOS (complimentary metallic oxide silicon) type. This I.C was incorporated into the circuit because of the low power consumption [2]. This is an advantage because there would be no need to worry about the device power consumption.

The logic control unit deals with the starting of the generator when there is power outage. The mechanism basically isolates the generator from the load during the moments after starting. When the alternator of the generator attains a steady current, the logic control connects the power to the load. The load is supposed to be lower than the output power from the generator [7].

The power sources are indirectly linked to the logic unit through the switching unit. The control unit channels power from devices to the load. The devices emphasizes on a single power supply due to the design. Immediately the main supply is restored the generator is cut-off.

2.3 GENERAL DESCRIPTION OF POWER SUPPLY

The complete range of power supplies are broad and could be said to include all forms of energy conversion from one form to the other [8]. Conventionally, the term is usually confined to electrical or mechanical energy supplies. Constraints that normally affect power sources are the amount of power, the duration of supply without needing refueling or recharging and the stability of their output voltage or current under varying load applications. The main emphasis is on the stability and performance of such power produced.

2.4 ELECTRICAL POWER SUPPLIES

The term covers the main power distribution system and any primary or secondary sources of energy such as:

(i) Conversion of one form of electrical power to another desired form. This is the conversion of 120 or 240 A.C supplied by a utility company to a lower voltage or D.C output.

(ii) Batteries- rechargeable and non-rechargeable.

(iii) chemical fuels

(iv) solar power

(v) generators

CHAPTER THREE

3.1 DESIGN AND IMPLEMENTATION

The project involves the following units:

1. Power supply 1
2. Power supply 2
3. Control logic unit
4. Motor terminal
5. Output Load

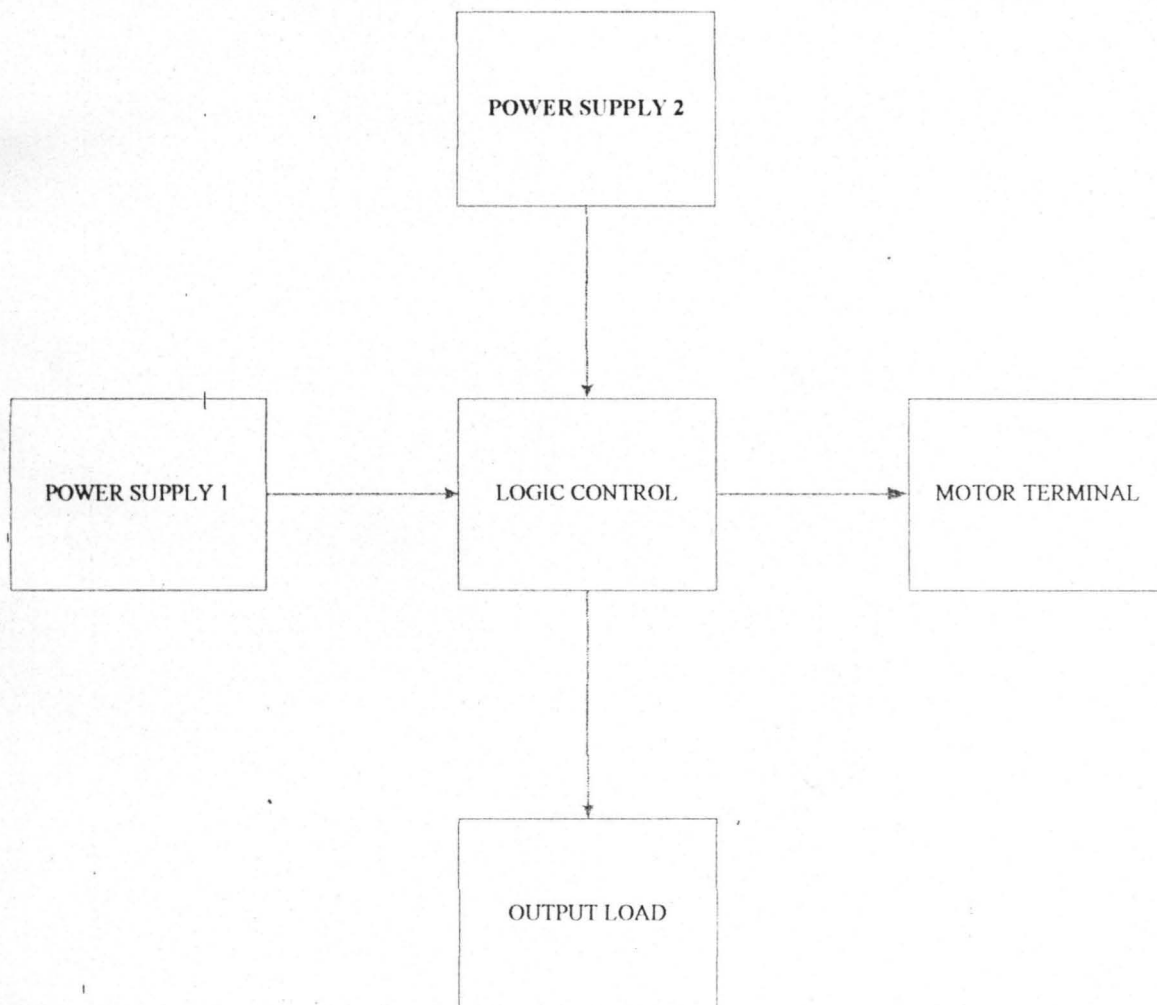

Fig 3.1 block diagram of the circuit

3.1.1 POWER SUPPLY 1

The power supply 1 is designed to provide a control voltage from the ac mains for the circuit. It consists of a 12V output step-down transformer and common four diode bridge rectifiers (but without capacitor ripple filtration). A transformer is a static apparatus by which electric power in one circuit is transformed into electric power of the same frequency [4].it can raise or lower voltage

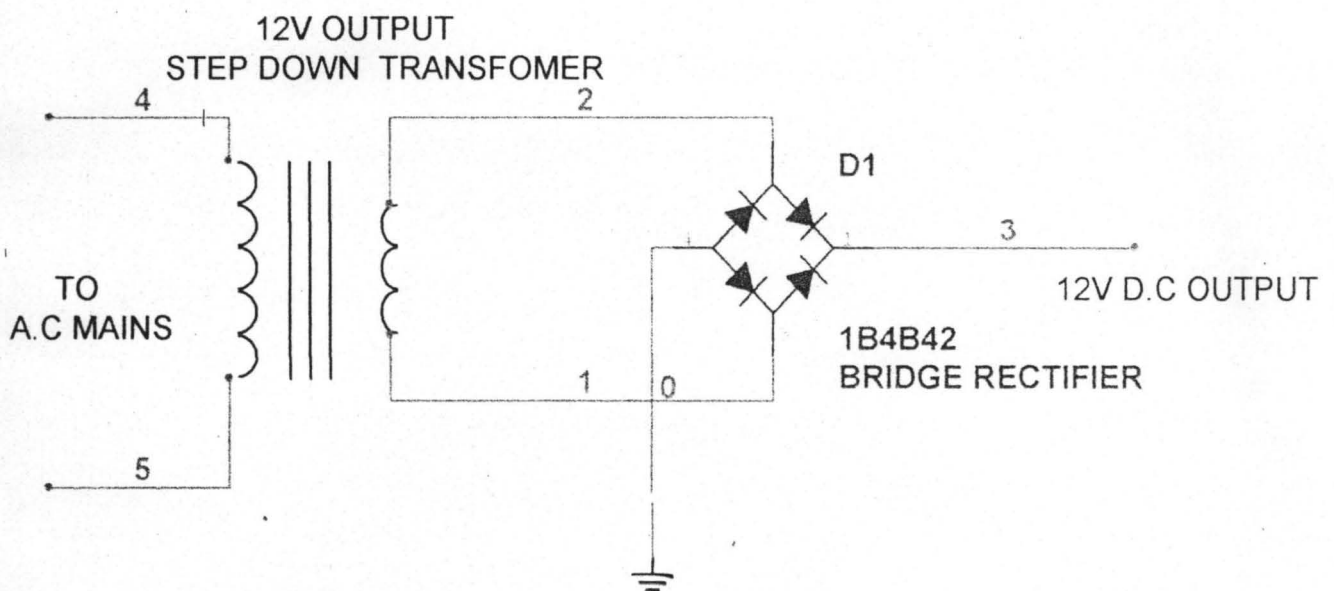

Fig.3.2 power supply 1

The transformer allows the conversion of the normal 220volts Ac mains supply to 12V AC. Because a DC voltage is required for the design, a bridge rectifier is incorporated into the circuit to rectify the 12V AC into corresponding DC. The voltage is not filtered with a capacitor due to unwanted time delay or voltage discharge that is attributed to the application of such components in a circuit.

For clarity power supply 1 is attained to supply or control relay 3. If the power supply is related to a large capacitor, such as the ones used in power filtration, the switching time or action of the related relay is slowed or delayed and unsuitable for fast switching response. Power supply 1 is the input of the circuit.

3.1.2 POWER SUPPLY 2

This is a 12V battery power source. It is intended to supply the whole circuit whenever the main power fails. This power source is connected to the circuit through relay 3. The relay is controlled by power supply 1. As stated earlier the circuit is connected to the battery power source.

Power supply 2 consists of two 6V rechargeable batteries connected in series the output voltage is 12V.

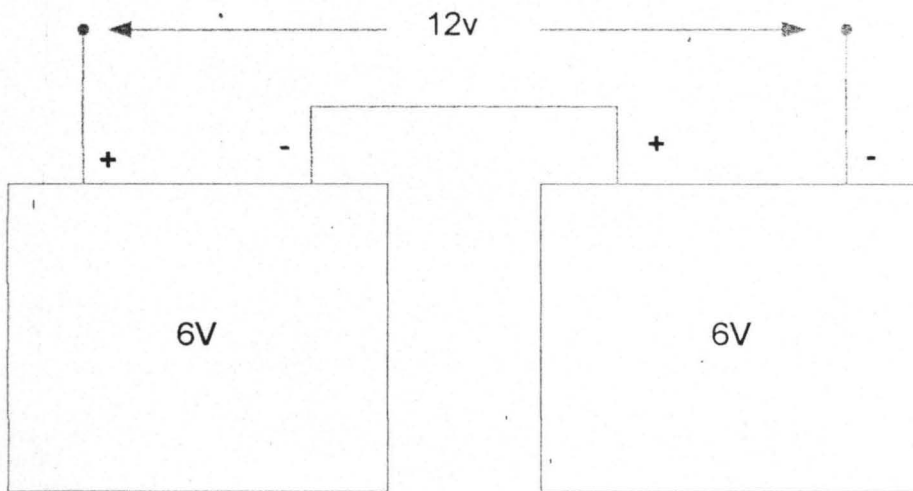

Fig 3.3 power supply 2

Each battery is rated 4AH. And due to the series connection of the two batteries, the ratings remain the same.

3.1.3 CONTROL LOGIC UNIT.

The control logic unit operation is based on sequential timing. The main component of the unit is a control oscillator (4060B). This device initiates the required switching in the circuit. Although, the device has ten control terminals, only two are involved in the circuit for controlling two latches.

The 4060B is a CMOS RC/crystals oscillator/divider integrated circuit. It is usually configured in the RC mode. Its pin 12 is required logic zero or ground for normal operation. Pin 9, 10 and 11 are output 1, output 2 and clock terminals respectively. They are needed for the RC oscillator mode. The device work's within 3-18 volts power supply.

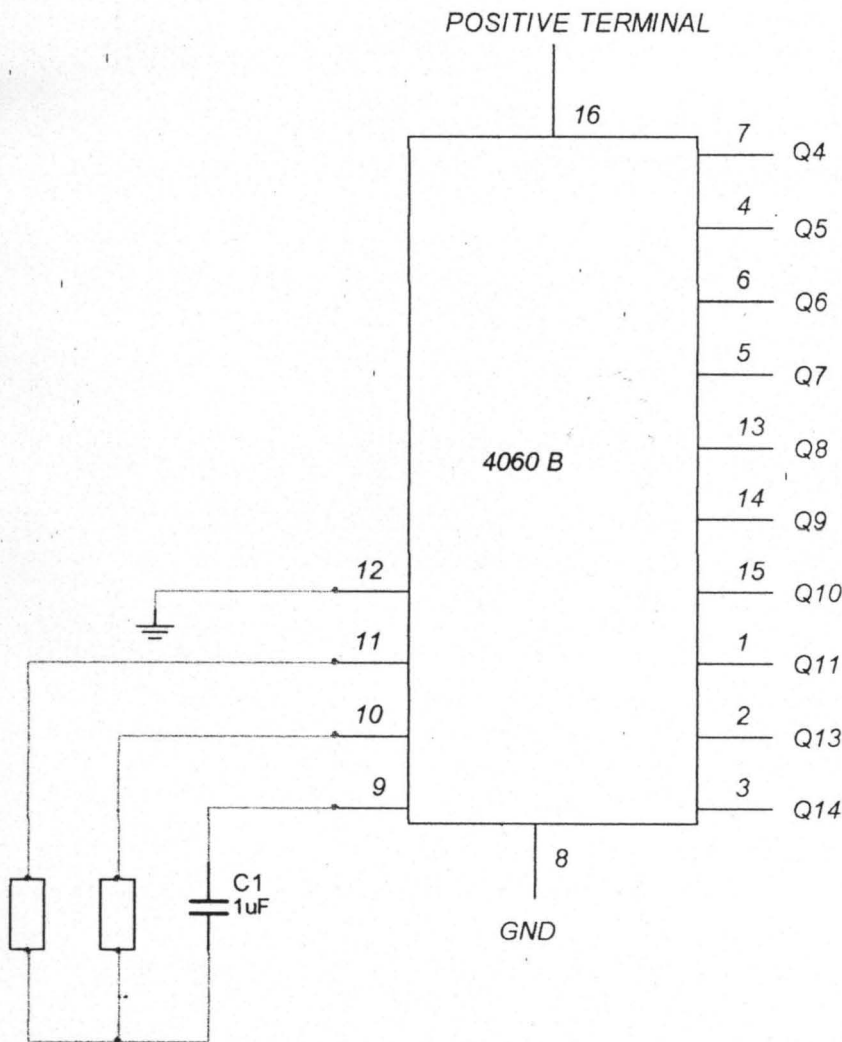

Fig.3.4 the normal RC mode of the 4060B showing its pin configuration.

The 10 output signals are derived from a main frequency.

The main frequency is given by:

$$F_m = 1/(2.3R_{tc} * C_{tc})$$

Where $10 R_{tc} \geq R_5 \geq 2R_{tc}$

The typical values of R_5 , R_{tc} and C_{tc} are 100 kilo ohms, 33 kilo ohms and 0.001 micro farad.

Therefore $F_m = 1/(2.3 * 33 * 10^3 * 0.001 * 10^{-6})$

$$F_m = 13.2 \text{ KHz}$$

The output frequencies are based on the following formula;

$$F_{qx} = F_m / 2^x$$

Frequency output from pin 2 is given by

$$(F_{q13} = F_m / 2^{13}) = 13.2 * 10^3 / 2^{13}$$

$$F_{q13} = 1.61 \text{ Hz}$$

$$T_{q13} = 1 / F_{q13}$$

$$T_{q13} = 1 / 1.61 = 0.62 \text{ sec}$$

Frequency output from pin 3 is given by

$$F_{q14} = F_m / 2^{14} = 13.2 * 10^3 / 2^{14}$$

$$F_{q14} = 0.81 \text{ Hz}$$

$$T_{q14} = 1 / F_{q14}$$

$$T_{q14} = 1 / 0.81$$

$$T_{q14} = 1.23 \text{ sec}$$

These signals are used for switching or controlling two latches which deals with motor and change-over control. These devices are derived from a 4013B integrated circuit. The device poses two independent latches. They work with active high input signals.

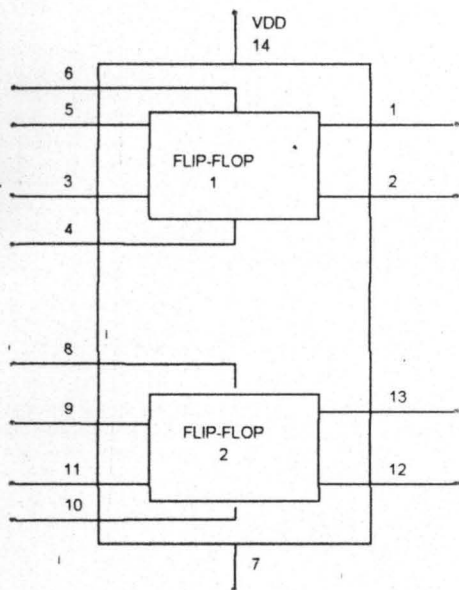

Fig.3.5 showing the internal circuit of a 4013B

Although, the 4013B is really designed for D type application. The latches in the circuit are configured in the SR mode by grounding the corresponding clock and D inputs

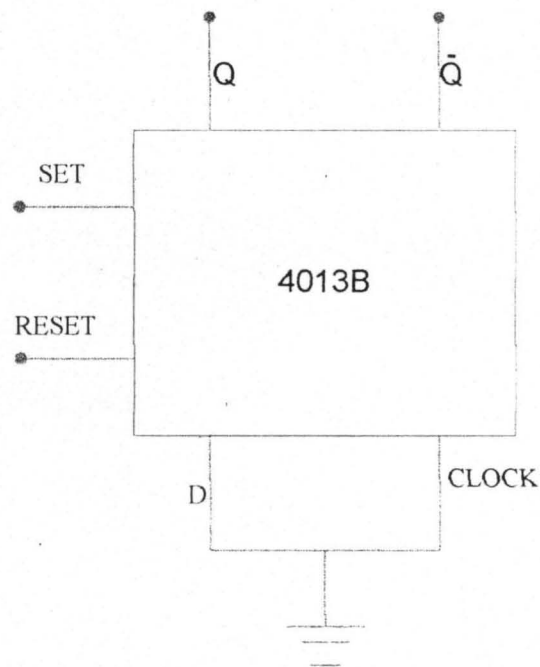

fig.3.6 a D-Type latch at SR mode

As earlier stated, two of such latches are required for the circuit. One controls relay 1 which switches on and off the motor/starter. The other latch handles the change over

operation between expected power supply from the auxiliary power source and the AC mains to a particular load.

Table 3.1 truth table of 4013B

S	R	Q	Q
1	0	1	0
0	1	0	1
0	0	X	X
1	1	1	1

3.1.4 MOTOR TERMINAL

The motor terminal is intended for an electric motor which starts an internal combustion engine that powers an alternator. Because the project is a prototype this terminal is connected to a 12V electric motor. When electricity is supplied to terminal of the motor, it works within a short time then after a particular time which is controlled by the oscillator the engine switches on.

3.1.5 OUTPUT LOAD

The output load is represented by a 60watts electric bulb. This terminal is required to supply the wiring of a building with electricity from either the common or normal AC mains power supply or auxiliary power supply such as a generator. The circuit allows relatively constant power supply to the terminal by interchanging supply between the two sources. For clarity, the expected power supply from a generator is indented to back up the normal AC mains power supply.

3.2 THE OPERATING PRINCIPLE OF THE CIRCUIT

The input of the circuit is the 12V output step down transformer. Whenever power is supplied to the device, relay 3 is energized. Terminals C₃ and B₃ of the device are connected together. C₃ is to be connected to A₃ for power supply to circuit through the 12V battery. This is done, when power is cut from the transformer. All grounds or negative terminals are common.

The first important action as related to circuit is the automatic resetting of both latches through a Schmitt trigger AND gate (4093B). The gate allows Q and Q of the latches to be logical zero and one respectively this required for normal starting state. For the motor control latch Q is connected to Q₁ through the base. The NPN device controls relay. For Q to be logical 1, means Q₁ is saturated and relay 1 is energized. Terminals C₁ and B₁ of the relay is connected together. The operation allows electric current to flow through the motor/starter. It is noted that one of the motors terminals is already input to 12V+ terminals. The switching of the relay allows the other terminal to be negative where by completing the circuit of the electric motor.

The control oscillator starts timing immediately the relay 3 supplies electric current to the logic control unit. Pin 2 of the control oscillator is related to 1.6Hz or 0.6sec signal. Therefore the motor control latch is set by the control oscillator around 0.62sec after power losses at the input step down transformer.

The set action changes Q of the motor control latch from logical 1 to zero. And logical zero at the base of Q₁ results into disabling or cut off mode of the device. There

by disengaging terminal B₁ and C₁ of relay 1. C₁ now joins to A₁. The result is the open circuit for the electric motor.

Signal from pin 3 of the control oscillator is used for setting the change over latch. The initial condition of the latch's output after reset by the Schmitt trigger AND gate is Q logical 1 and Q logical zero. The Q output is connected to the base of Q₂. Therefore the leading transistor is cut off. The result is that terminals A₂ and C₂ of relay 2 are connected together.

Relay 2 supplies life power supply to the output load from two sources, G and M. M represent life power supply from the normal power mains or PHCN. G represents life power supply from the auxiliary power source.

Therefore the initial condition is the supply of power to the load through the normal AC mains (e. g from PHCN). The control oscillator through its pin 3, set the change over latch for the Q output to change from logical zero to 1 for Q₂ to be saturated in reversing the output condition of relay 2. The switching time of the change over operation is the period of the signal from pin 3 (1.23sec). The fact is that timing is quite longer than the calculated values due to internal capacitance of the circuit and variations of frequency

3.3 THE RELAY SWITCHING CIRCUIT

A relay is an electromagnetic device that is used by varying the input in order to get a desired output. Relays are of two types, the normally closed and normally open[5]. The type used in this project is the normally open relay.

It is a good and common practice to switch a relay with a transistor NPN type to be specific. The transistor is set in the common emitter configuration.

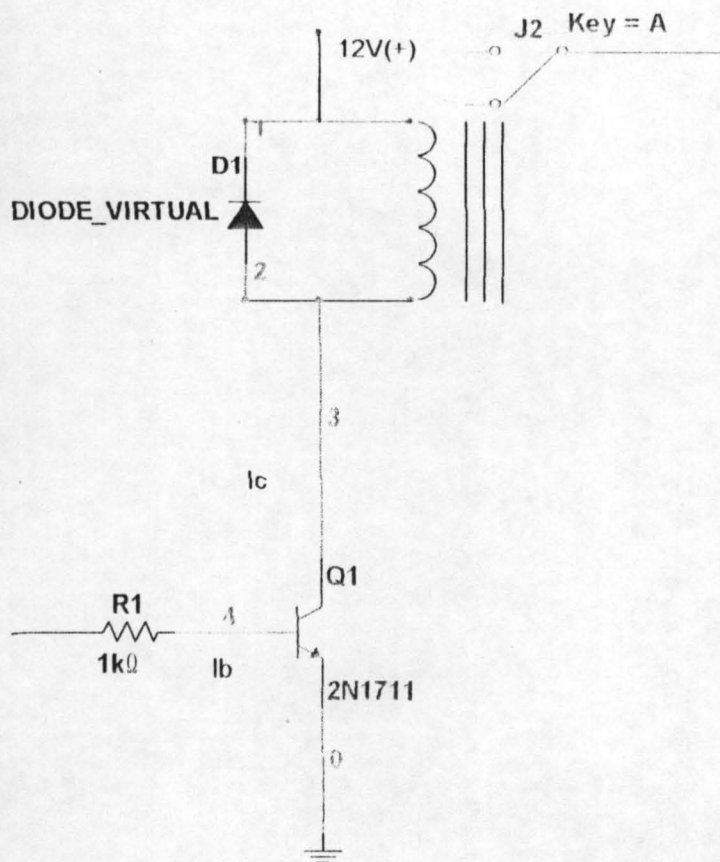

Fig 3.7 relay switching circuit

3.4 THE TRANSISTOR

The transistor in use is 25C945. It is an NPN device with maximum current and voltage ratings of 100 milli amperes and 50Volts. It posses a typical current gain of 100.

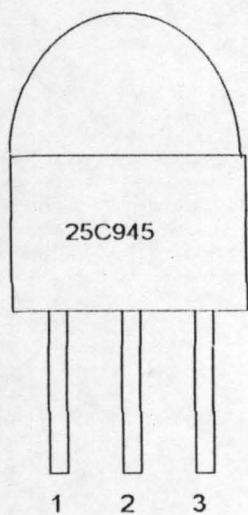

Fig 3.8 an 25C945 NPN transistor showing its pin

The resultant load or resistance of the relay in the transistors collector is 400 ohms.

Therefore for full saturation of the transistor the collector current is given below.

$$I_C = V_{cc}/\text{load}$$

$$I_C = 12/400$$

$$I_C = 0.03\text{A or } 30\text{mA}$$

$$I_B = I_C/100$$

$$I_B = 30 \times 10^{-3}/100 = 0.3\text{mA}$$

$$I_B = 0.3\text{mA}$$

The expected base resistance is given by,

$$R_B = V_{cc} - 0.6 / I_B$$

$$R_B = 12 - 0.6 / 0.3 \times 10^{-3}$$

$$R_B = 38\text{Kohms}$$

In practical situation, the calculated R_B is unsuitable for switching a transistor loaded with such relay. The reasons are, numerous. But the most important fact is that, there is a reasonable voltage drop across the output of the latches due to impedance matching with the base of the corresponding transistor and transistors do not normally attain full saturation state during switching. 2.2Kohm resistor was used for the impedance in the circuit.

3.5 CIRCUIT CONSTRUCTION

The circuit's construction involved coordinated steps in coupling the components with respect to the circuit diagram. Therefore, the design was of great importance because the circuit is supposed to work as aimed.

The bread board construction was done and the circuit was working according to the design. The circuit was also simulated on an electronic work bench. Therefore, the construction was then made on the Vero board.

The Vero board mounting of the involved components was performed in accordance of the circuit diagram, because it was a permanent connection. The construction was made in bit in accord with the early grouping of the circuit's diagram. The step was aimed to prevent confusion or mistake during construction. The construction mainly involved soldering of the involved components, through wires or other medium.

The following are the main tools and materials used during the construction

1. soldering iron
2. soldering lead
3. Vero board
4. Razor blade.
5. scissors
6. pillars
7. glue
8. file
9. knife edge cutter

3.6 CASING CONSTRUCTION

The casing was a wooden base which held the external components such as electric bulb, motor and the circuit enclosure. The layout was made to put more understanding to the operation of the device.

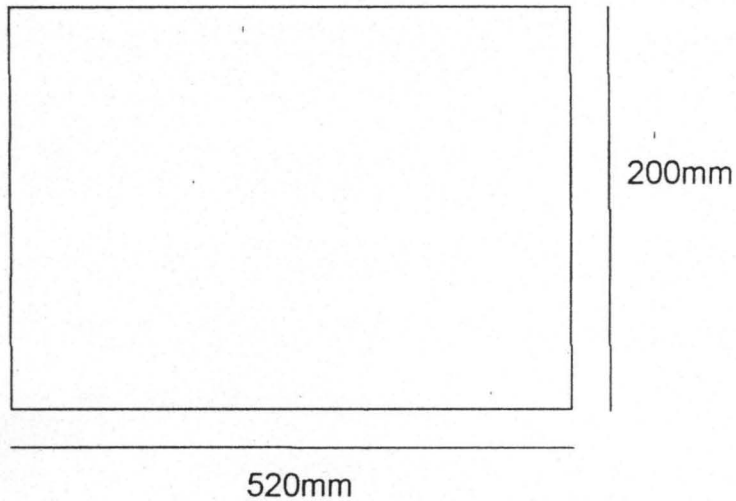

Fig 3.9 the dimension of the wooden platform

The main circuit was cased with a modified rubber casing. It was mounted on the wooden platforms which also accumulate a 12V battery (constructed using two 6V batteries in parallel connection).

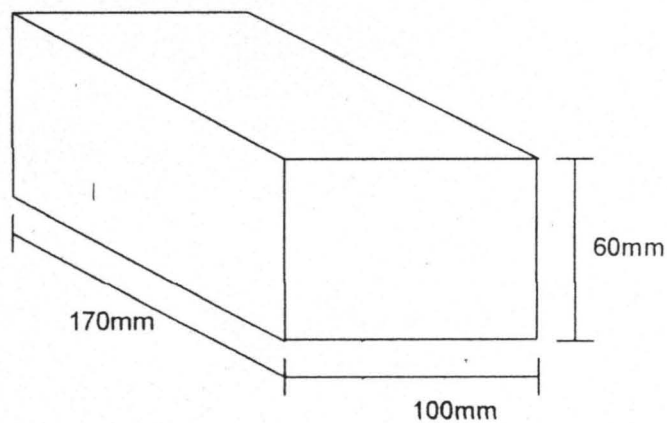

Fig 3.10 the dimension of the circuit's casing

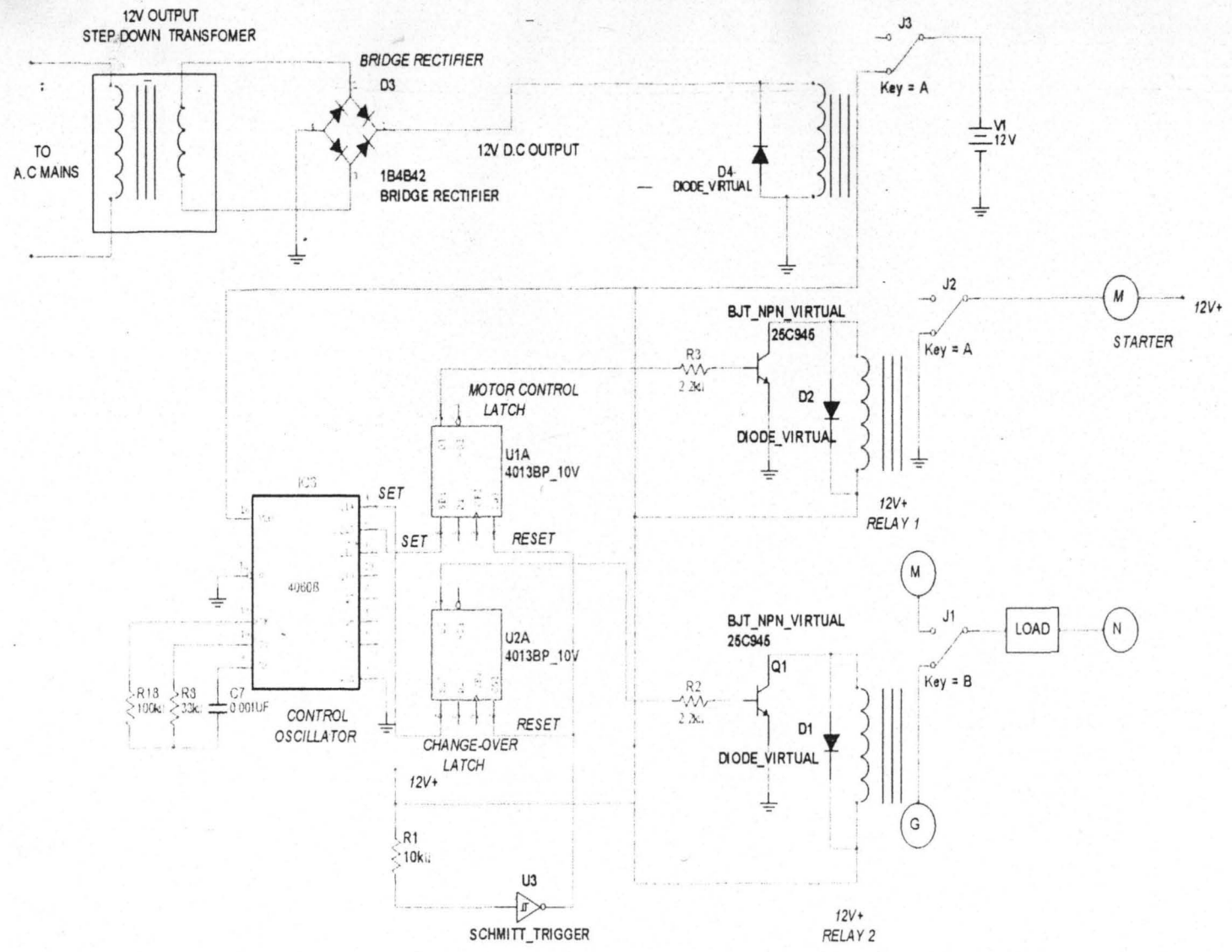

Fig.3.11 circuit diagram of the project

CHAPTER FOUR

TESTING AND DISCUSSION OF RESULT

4.1 TESTING

The testing of the project involved putting the set up with a wiring connecting to the battery. The mains control point was a 3 phase socket box. It involved three plugs respecting the Neutral, generator and AC main supply line. The control of the device was done on the socket box by putting in place and removal of the live terminal while the neutral was intact. The following diagram shows the steps taken in testing the work.

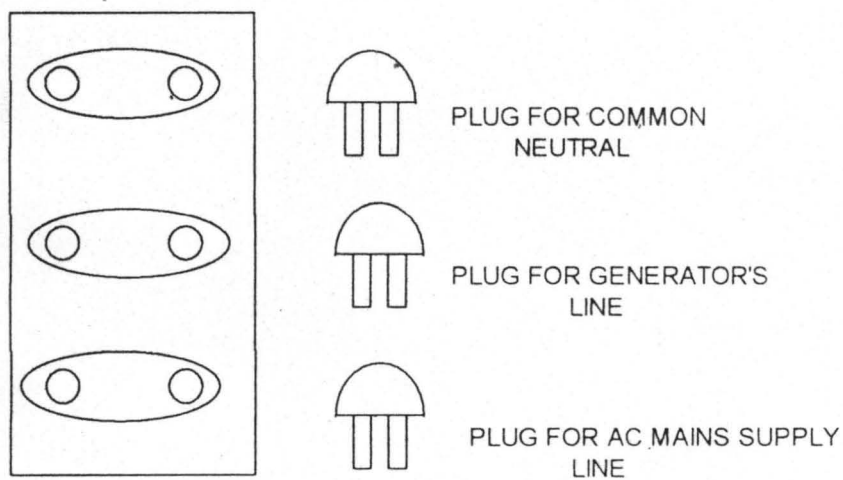
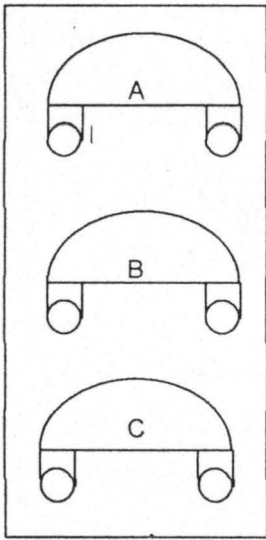
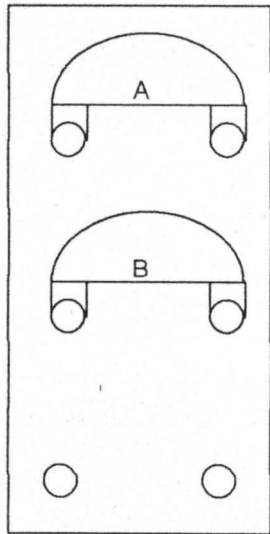

FIG 4.3 CONTROL BOX



IN STEP ONE
THE THREE
PIN PLUG
PUT IN PLACE



STEP TWO INVOLVES THE
REMOVAL OF THE PLUG
(THE AC MAINS SUPPLY)
FROM THE CONTROL
SOCKET

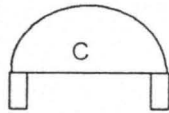

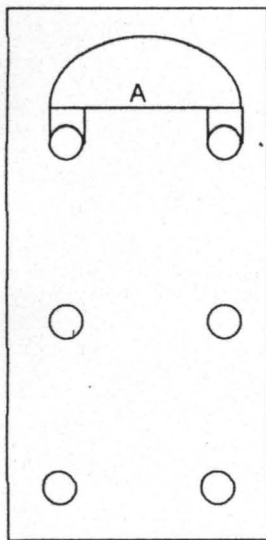

STEP THREE INVOLVES
THE REMOVAL OF
BOTH LIVES FROM THE
MAINS

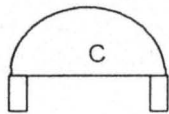
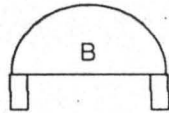

The steps were performed several times to check the accuracy of the outcome. The electric bulb and motor were output for results.

4.2 RESULT AND DISCUSSION OF RESULT

The following steps were involved in the operation of the circuit.

4.2.1 THE FIRST STEP

Unplugging both the three plugs and the battery from the terminal made the device useless. When the batteries was properly fixed, and the control box's plug were in place, the bulb was on without any response from the electric motor with time. The condition remained the same indefinitely.

4.2.2 THE SECOND STEP

Unplugging plug C (for the main AC mains supply) resulted into switching off of the electric bulb with the motor's rotation for a specified period of time about four seconds before going off and after about four seconds later the electric bulb comes on again.

4.2.3 THE THIRD STEP

When plug B was unplugged from the socket the electric bulb went off, with no response from the electric motor. In fact, none of the early result was possible if the battery terminals were not properly connected in place.

4.2.4 FOURTH STEP

Plug C was plugged back into the control box.

4.3 DISCUSSION OF RESULT

When the three plugs were not in place the circuit, was no result. The electric bulb went off when plug C was removed because it was powered by the line. The removal of the plug allowed DC power supply to the circuit through a relay switch which connects the circuit to the incorporated 12V battery. The electric motor represents the normal starter for normal internal combustion engine of a generator. It is normally required to work for a short period of time in getting the engine started.

There was a delay of about four seconds, after the electric motor stopped working, before the light came again. The removal of the plug B after the light comes on was to show or justify the source of electricity to the electric bulb which was line through plug B. The light went off in response to the removal of plug B. If the plug is put back into place the light should come on

The plugging back of the plug C to the control socket allowed the electric bulb under the power of the normal AC mains power supply. The bulb went off for a time that is negligible to the human eyes.

4.3.1 TROUBLE SHOOTING

The device worked properly after testing, but was found to have a very high switching speed time. This was not the required timing. The speed was adjusted to give more time before the relay switches on the motor.

CHAPTER FIVE

CONCLUSION AND RECOMMENDATION

5.1 CONCLUSION

After the design, construction and trouble shooting phases, the prototype automatic change-over was working according to the specified constraints. A 60 watts bulb was used as the load and the D.C motor served as the starter of the generator. The device worked in accordance with the design.

5.2 RECOMMENDATION

1. Higher current capacity relays should be employed.
2. Timing circuitry could be incorporated into the design to allow different delay in switching.
3. A microprocessor could act as a replacement of integrated circuit improved flexibility and performance.
4. A 3 – Phase power application of the circuit is possible with little modification.

REFERENCES

1. www.kspec.uk.com/technology/electronics/7806.html
2. Microsoft Encarta Premium 2006 edition
3. National semi-conductor data sheets
- 4 B.L Theraja & A.K Theraja, A text book on electrical technology in S.I system of units: transformers, 21st Edition, Rajendra Ravindra(Pvt) Ltd,New Delhi,2002,p919.
5. Thomas L. Floyd,.Digital fundamentals: Integrated Circuits, 6th edition,prentice –hall,Inc,New Jersey, 1997, p123-124.
6. Texas instrument data sheets
7. www.wikipedia.com/inverters/switchover/
8. www.howstuffworks.com/automaticswitch/
9. Britannica encyclopedia 2004 edition