

DESIGN AND CONSTRUCTION OF AN
AUTOMATIC PUMP CONTROL UNIT
SYSTEM
WITH AUDIO/VISUAL INDICATORS.

BY

DAVID BABATSI NMADU.

97/5972EE

DEPARTMENT OF ELECTRICAL AND COMPUTER
ENGINEERING,
SCHOOL OF ENGINEERING AND ENGINEERING
TECHNOLOGY,
FEDERAL UNIVERSITY OF TECHNOLOGY, MINNA
NIGER – STATE.

SEPTEMBER 2003.

DESIGN AND CONSTRUCTION OF AN
AUTOMATIC PUMP CONTROL UNIT
SYSTEM
WITH AUDIO/VISUAL INDICATORS.

BY

DAVID BABATSI NMADU.

97/5972EE

DEPARTMENT OF ELECTRICAL AND COMPUTER
ENGINEERING,
FEDERAL UNIVERSITY OF TECHNOLOGY, MINNA
NIGER – STATE.

SUBMITTED IN PARTIAL FULFILMENT OF THE BACHELOR
OF ENGINEERING (B. ENG.) DEGREE IN THE
DEPARTMENT OF ELECTRICAL AND COMPUTER
ENGINEERING,
FEDERAL UNIVERSITY OF TECHNOLOGY, MINNA.

SEPTEMBER 2003.

CERTIFICATION.

I certify that this project was fully carried out by David Babatsu Nmadu, department of Electrical/Computer Engineering, Federal University of Technology Minna.



Engr. F.O. Attah
Supervisor



Date.

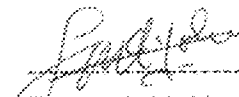

Engr. M. N. Nwohu
Head of department



Date.

External Examiner.

Date.

DECLARATION.

I hereby declare that this project work presented for the award of bachelor of Engineering (B.ENG.) in the department of Electrical/Computer Engineering, Federal University of Technology, Minna, has not been presented elsewhere

DEDICATION.

This project is dedicated to the LORD GOD ALMIGHTY and in memory of my late
aunt Mrs. Lydia L. Jya.

ACKNOWLEDGEMENT

With thanks to Almighty GOD for his guidance and mercy, I sincerely acknowledge the support of the following people who contributed in various ways, which are too numerous to mention, I so pray, and desire that the LORD GOD Almighty bless and keep you all.

- My Father Mr. Abel Nmadu, My brother Mr. Daniel Nmadu and Sisters Mrs. Dorcas Tsado and Mrs. Elizabeth Mannassah for their love, support, encouragement and understanding.

- My uncle Mr. Paul .M. Jiya for his invaluable support and inspiration.

- My brothers, sisters and cousins Suleiman .G. Jiya, Dr. Samuel Jiya, Grace Jiya, Yakubu Jiya, Comfort .A. Jiya, Annah Jiya, David Gana, Samson Gana, Rachael Nmadu, Emmanuel Nmadu, Theophilus Nmadu, Mr. Moses Jiya, Thomas .B. Jiya, David .B. Jiya and several others but few to mention for their support, prayers and encouragement.

- My good friends Dr. Miss crown in the U.K, Matilda Kyon, Mr. and Mrs. Segun Philips for their inevitable support and inspiration.

My friends Emmanuel Akut and Maanas Edward (S.D) whom have seen to successful realization of the printed work.

I am so much greatly indebted to a colleague and a friend in person of Mr. Kunle Elijah for his unflinching support and to the realization of the working operation of the thesis. I must acknowledge the technical advice offered to me by my Project supervisor Engr. P.O. Attah, Department of Electrical/Computer Engineering, Federal University of Technology Minna.

ABSTRACT

This thesis provides an explanation on the theory, design and construction of an automatic pump control unit system. The device is electronically operated to control the level of liquid (water) in a tank. It is also capable of producing audio and visual outputs whenever water level reached a specified level. This was achieved by using the resistance of water in a voltage divider network across a 12V dc power supply, which forward biases the BC109 transistor into saturation. The output of the transistor energizes the relay coils that control the pumping action of the motor.

TABLE OF CONTENTS

<i>Contents</i>	<i>Pages</i>
Front page	i
Title page	ii
Certification	iii
Declaration	iv
Dedication	v
Acknowledgement	vi
Abstract	vii
Table of contents	viii
 CHAPTER ONE	
1.1 General introduction	1
1.2 Literature review	2
1.3. Project objective/motivation	3
 CHAPTER TWO	
2.1 Theory and design	5
2.1.1 Principle of operation of the automatic pump control unit system	5
2.1.2 The voltage divider biasing	5
2.1.3 D.C analysis of bipolar junction transistor	6
2.1.4 Common-emitter configuration	7
2.1.5 Block diagram	8
2.2 Circuit design and construction	9
2.2.1 DC power supply	9
2.2.2 Transformer selection	10
2.2.3. Rectifier selection	10
2.2.4: Averages and r.m.s values	11
2.2.5 Ripple factor	11
2.2.6 Peak inverse voltage (piv)	11
2.2.7 Filtering capacitor selection	12
2.2.8 The basic capacitor filter	12

2.2.9 Effect of increasing filter capacitance	12
2.2.10 Voltage regulator selection	13
2.2.11 Three-terminal voltage regulator	14
2.2.12 Theory of water conductivity	15
2.2.13 Design procedures	16
2.2.14 The switching action of transistor Q_1 and Q_2	17
2.2.15 Astable multivibrator	19
CHAPTER THREE	
The Designed operation	22
3.0. Operation of the automatic pump control unit system	22
3.0.1. When the tank is empty	23
3.0.2 When it makes contact with the lower probe	23
3.0.3 When it makes contact with the upper probe	23
3.0.4 When the water level falls below the upper probe	24
3.0.5. When the water level falls below the lower probe	24
3.1 For no water flow alarming circuitry	25
3.2. For low indicating circuitry	25
3.3. For high indicating circuitry	26
3.4. For over-flow alarming circuitry	26
3.5 Brief description of the CMOS 4001	26
3.6 Evaluation of relay coil shunt diode	27
3.7. Protection against short circuit	27
3.8. Construction	27
3.9. Testing	28
3.10. Result	28
CHAPTER FOUR	
Conclusion and recommendation	29
4.0 Conclusion	29
4.1 Recommendations	29
Circuit diagram	30
Appendix	31
List of references	32

CHAPTER ONE

1.1 GENERAL INTRODUCTION

Flood, for so many years now has been a problem to many hydroelectric power plants. For instance, Shiroro power station in Niger state experienced flood some years ago due to gradual water leakage from its opened draft tube inspection door, during annual maintenance of the machines.

The situation became worse when the electric motor driving the pump to pump-out the water failed to start. For the fact the flooding was not immediately detected, it became difficult to control.

Imagine that the flooding was immediately detected, the draft tube inspection door would have been closed and the flood would have been avoided completely.

Similarly, Kaduna refining and petrochemical company (K R P C) located in the southern part of Kaduna state experienced flooding in its generating power plant where water in boilers are reserved for the running of the entire company and its environs, due to the fact that the operator whose work is to check the water level intake was far asleep.

Furthermore, imagine a domestic overhead water tank, which receives water from public water supply line, the water may over flow to flood the house when there is no device to detect that the tank is getting filled.

Other cases of flooding do exist in water treatment plants and many other places where water is used. Most of this flooding became uncontrollable because they were not detected earlier on.

Hence, this proposed device is intended to detect electronically the level of water in a tank (compartment), it is used in sensing the liquid level inside a container (compartment), which in turn will start up the pump for the filling of the tank in order not to run short of such liquid, it also control the stoppage of the pumping machine whenever the level of the liquid reaches the desired level in the tank via the second pair of sensing element. It operates automatically as long as the copper-sensing element is not corroded.

Since the world is dynamic and it is the aim of this project to improve upon the existing liquid level control device.

Therefore an improvement is quite necessary as an innovation.

This project is based on the use of semi-conductors and integrated circuits, which are bases of electronic engineering.

1.2 LITERATURE REVIEW

The use of float switches in detection and control of water level has been in existence for a very long time. These float switches are used in industries where water level need to be detected or controlled. The basic principle of a float switch is that, one of the switch contact floats on water while the other contact is made to be stationary. As water rises, the float rises until the switch becomes closed. This contact may be part of a motor control circuit, which drives a pump. Float switches have some mechanical elements since there is movement before contact is made in them. On the other hand, electronic devices have been used as switches. These include: temperature operated switch, pressure operated switch, light operated switch etc. Most of these switches are sensors. The sensor may be in a voltage divider network to apply potential to a switching circuit.

Some of the switching circuits include: single transistors circuit, thyristors switching, Schmitt trigger switching circuit etc.

Earlier, Barry G. W. (1984) revealed that single transistor could be used as light operated switch. In his design, a photocell was used in a voltage divider network to forward bias or reverse bias a transistor depending on the intensity of light on the photocell.

Furthermore, Williams D. S. (1989) used an operational-amplifier to build a Schmitt trigger. This was achieved by providing a positive feed back in the operational amplifier circuit. The circuit is shown below:

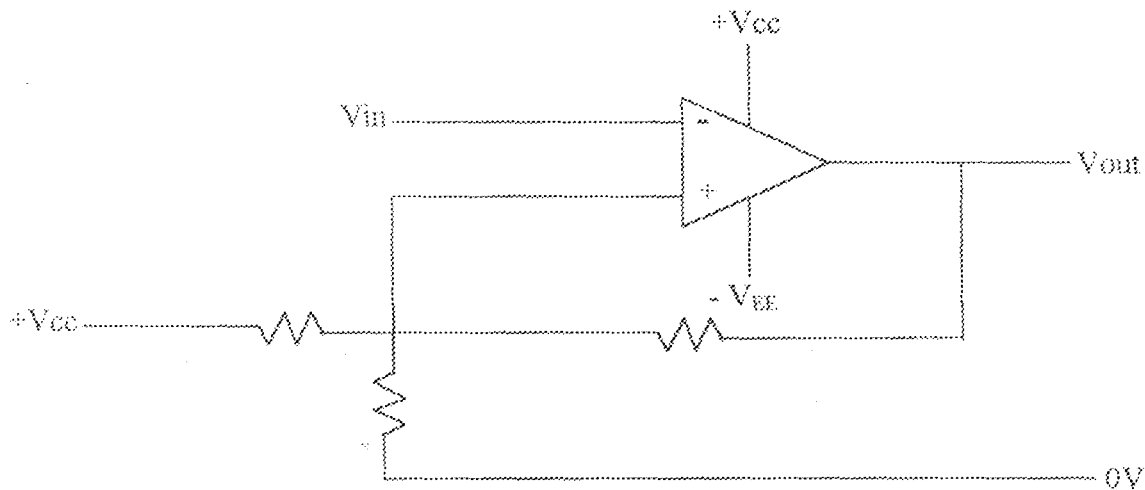

Fig. 1.2. Operational-amplifier as Schmitt trigger.

The circuit has a positive reference voltage on non-inverting input. The upper and lower trip points are both positive. For further details, list of references are provided at the end of this report.

Charles A.H. (1978) built a Schmitt trigger using two transistors. This was achieved by introducing hysteresis using positive feedback. This design employs the use of transistors and relays.

Conductivity of water is an important factor in the design of this proposed device. Water resistance forms a path in the voltage divider network, which switches ON or OFF the Schmitt trigger.

Loach W. (1981), revealed the conductivities of different sources of water. The conductivity of water according to Loach W. depends on the movement of ions in the water. These ions are dissolved species carrying an electric charge. Hence, the higher the number of ions, the greater the conductivity.

1.3 PROJECT OBJECTIVE/MOTIVATION

Recent flood disaster in hydro electric power plants and some other domestic overhead tanks has made it necessary to design and construct an electronic water level detector. For the fact that the float switch type of detectors are prone to failure and human effort wasted, it has become necessary to construct a cheaper

automatic system which could monitor the liquid level and control the pumping action of the motor and also sound a warning as a result of any fault within the system.

CHAPTER TWO

2.1 THEORY AND DESIGN.

2.1.1 PRINCIPLE OF OPERATION OF THE AUTOMATIC PUMP CONTROL UNIT SYSTEM.

The design makes use of a simple conductor strands as the sensor probes which together with two logic ICs form the sensory module. The body of the metal tank is connected to the negative terminal of the rectifier circuit. The circuit is powered from the rectifier and well regulated dc power supply. The position of the copper conductor (sensor) with the liquid determines the input voltage level to these two-input digital integrated circuit. The output of biases the BC109 switching transistors. A high voltage from the logic gate output switches the transistor into saturation. This serves as the energizing input to the dc relay that puts the circuit into operation as required.

The single phase pump is used in pumping the water at a remote position from the tank into another compartment, as the need arises.

The potentiometers in the circuit are to regulate the sensitivity of the probes with respect to the different liquid used.

2.1.2 THE VOLTAGE DIVIDER BIASING.

One of the biasing methods is the voltage divider biasing. These basically consist of two resistors R_1 and R_2 across a voltage V_{cc} . The voltage drop across R_2 , which is V_2 , forward bias the emitter-base junction usually called V_{BE} . An illustration is shown below

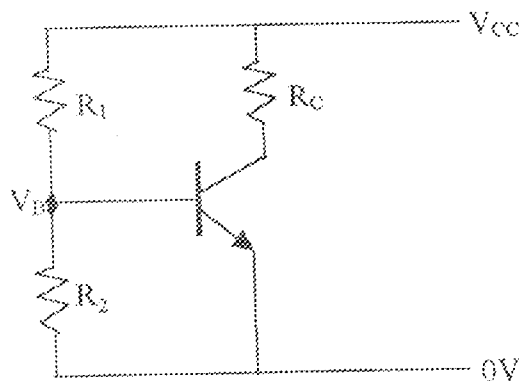

Fig. 2.1.2 (a) illustrating voltage divider biasing

By voltage divider formula

$$V_B = \frac{R_1 R_2}{R_1 + R_2} \times V_{CC} \quad (1)$$

Where V_B = Base voltage

R_1 and R_2 are the biasing resistors

$$R_B = \frac{R_1 R_2}{R_1 + R_2} \quad (2)$$

Where R_B = base resistor

The thevenin equivalent circuit of the voltage divider biasing is shown below:

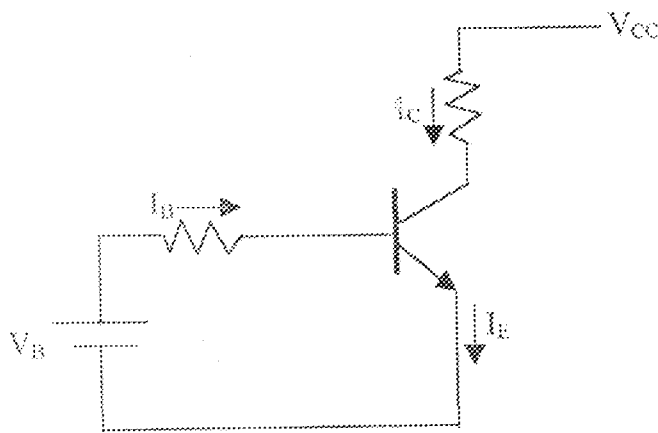

Fig.2.1.2 (b) Thevenin equivalent circuit of voltage divider biasing.

By kirchoffs voltage law (KVL)

$$V_B = I_B R_B + V_{BE} \quad (3)$$

Where V_{BE} is the base emitter voltage drop.

I_B is the base current.

$$\text{Also } V_{CC} = I_C R_C + V_{CE} \quad (4)$$

Where I_C collector current

V_{BE} = voltage drop across base-emitter junction in the transistor, It is 0.7V For silicon transistor and 0.3V For germanium transistor.

2.1.3 D.C ANALYSIS OF BIPOLAR JUNCTION TRANSISTOR.

As stated earlier, most of the transistors used in this design are in common-emitter configuration. Hence, emphasis shall be given to its dc analysis. Below is a circuit for NPN common-emitter connected transistor for the purpose of analysis.

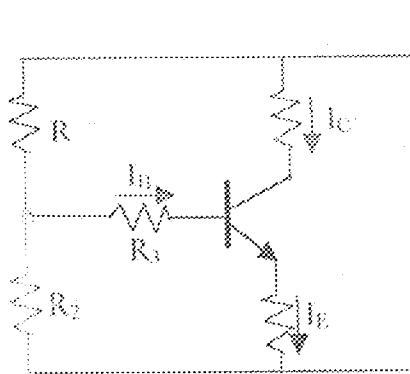
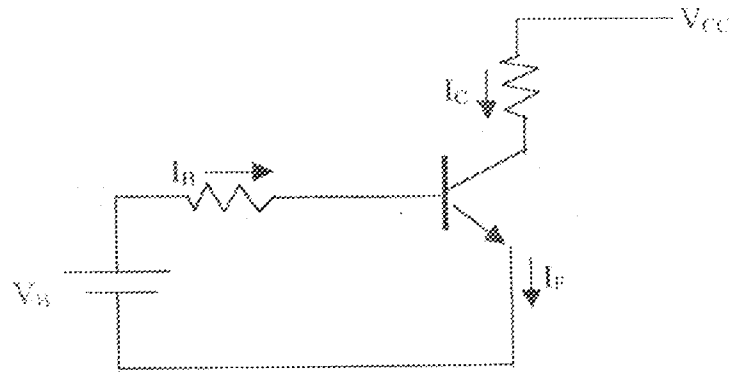

Fig. 2.1.3 (a) NPN transistor



(b) thevenin equivalent

2.1.4 COMMON-EMITTER CONFIGURATION

Now,
$$R_B = \frac{R_1 R_2}{R_1 + R_2 + R_3} \quad (5)$$

By voltage divider formula

$$V_B = \frac{R_2}{R_1 + R_2} \times V_{CC} \quad (6)$$

From fig (b), applying KVL

$$V_B = I_B R_B + V_{BE} + I_E R_E \quad (7)$$

$$\text{But } I_E = I_B + I_C \quad (8)$$

$$\text{Also } I_C = \beta I_B \quad (9)$$

$$I_E = I_B (1 + \beta)$$

Substituting equation (10) to (7) gives

$$V_B = I_B R_B + V_{BE} + R_E (1 + \beta) I_B \quad (10)$$

From which

$$I_B = \frac{V_B - V_{BE}}{R_B + R_E (1 + \beta)} \quad (11)$$

Similarly, by KVL of fig (b)

$$V_{CC} = I_C R_C + V_{CE} + I_B R_E$$

From which

$$V_{CE} = V_{CC} - I_C R_C - I_B R_E \quad (12)$$

2.1.5 BLOCK DIAGRAM

The project layout shall be presented in a block diagram as shown below.

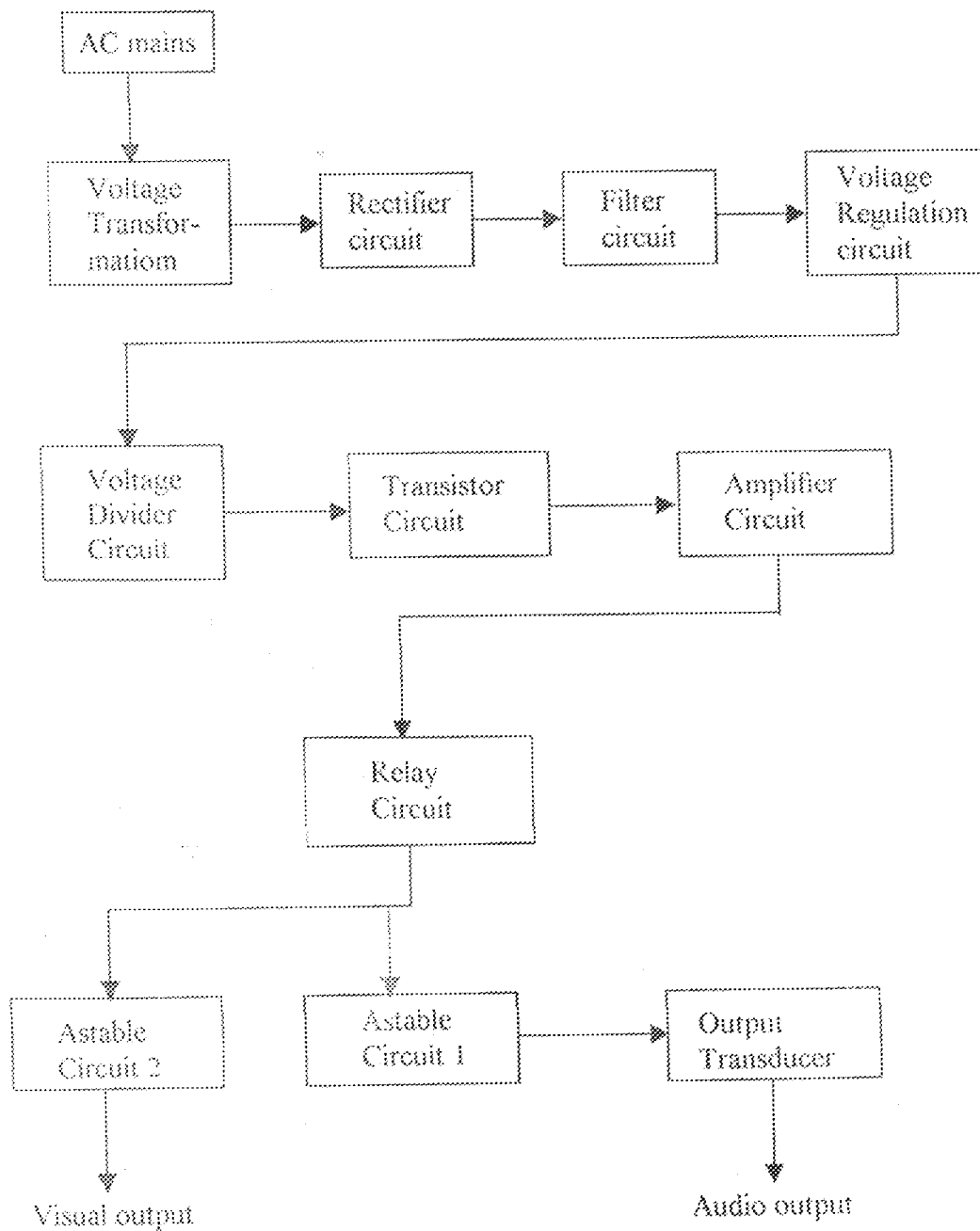

Fig.2.1.5 Schematic block diagram of an automatic pump control unit with audio/visual indicator

2.2 CIRCUIT DESIGN AND CONSTRUCTION

2.2.1 DC POWER SUPPLY

The most convenient economical source of power is the domestic ac supply. It is possible to convert this alternating voltage (usually 240 V_{rms}) to dc voltage (usually smaller in value).

Starting with an ac voltage a steady dc voltage is obtained by rectifying the ac voltage, the filtering to a dc desired fixed dc voltage. The regulation is usually obtained from an IC regulator unit, which takes a dc voltage and provides a somewhat lower dc voltage which the same even if the input dc voltage varies or the output load connected to dc voltage changes.

A typical diagram containing the parts of a typical power supply is shown below. This process of converting ac voltage is called rectifying and is accomplished with the aid of the following:

1. Transformer
2. Rectifier
3. Filter
4. Voltage regulator

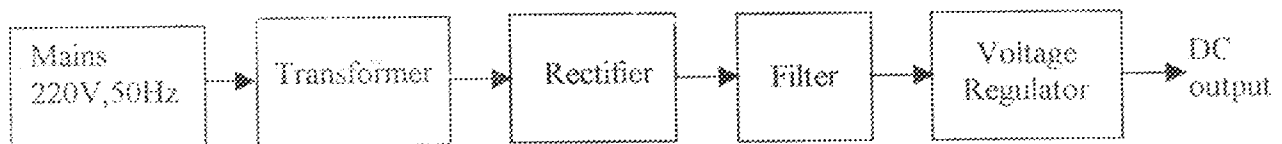

Fig. 2.2.1 Typical DC power supply block diagram

2.2.2 TRANSFORMER SELECTION.

A 240 V_{rms}/12 V_{rms} two-winding step-down transformer was used to step the 240Vac supply to the desired ac level.

The coil type transformer was chosen, because in this type of transformer the leakage flux is reduced. The primary and secondary windings surround a considerable part of the core. In the simplified diagram of the core-type transformer shown in fig 2.2.2 the primary and secondary windings are shown located in the opposite limbs of the core. The core is laminated to reduce energy (I^2RT) loss.

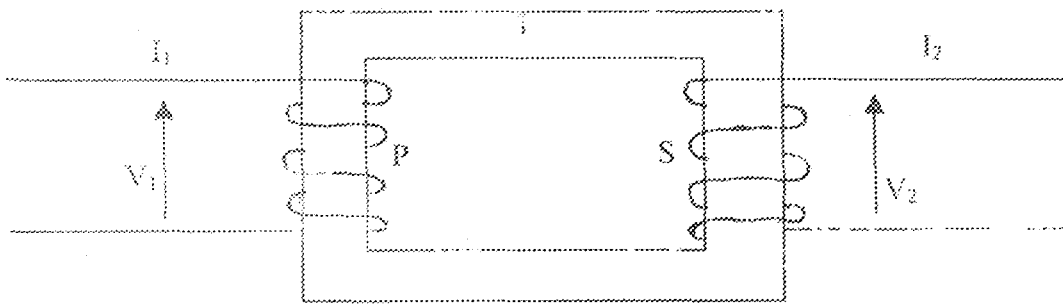

Fig. 2.2.2 A simplified diagram of a core-type transformer

2.2.3. RECTIFIER SELECTION.

The full-wave bridge rectifier is the most commonly used rectifier circuit for several reasons:

1. It does not require the use of a center-taped transformer.
2. It provides a high peak output voltage than the full-wave rectifier does. This ultimately a higher dc output voltage from the power supply.

It consists of four discrete diodes as shown in fig. 2.5 (a).

This was selected because of its availability, low cost and high break down voltage

2.2.4. AVERAGES AND R.M.S VALUES.

$V_{out(pk)}$ = peak output voltage of the rectifier circuit.

$V_2(pk)$ = secondary voltage of the transformer.

V_{ave} = dc output voltage.

I_{ave} = dc output current.

$V_{out(pk)} = V_2(pk)$ (ideal)

$V_{out(pk)} = V_2(pk) - 1.4V$ (considering the voltage drop along the two conducting diodes).

$$V_{2(pk)} = \frac{N_2}{N_1} V_{1(pk)} = \frac{V_{2(rms)}}{0.707} \quad (14)$$

$$V_{1(pk)} = \frac{V_{1(rms)}}{.707} \quad (15)$$

$$V_{ave} = \frac{2V_{outpk}}{\pi} \quad (16)$$

$$I_{ave} = \frac{V_{ave}}{R_L} \quad (17)$$

2.2.5 RIPPLE FACTOR.

When defined in terms of voltage, it is given by

$$R = \frac{\text{Ripple voltage (rms)}}{\text{DC voltage}} = \frac{V_{(rms)}}{V_d} \times 100\%$$

2.2.6 PEAK INVERSE VOLTAGE (PIV)

The peak inverse voltage rating of each of the four diodes is equal to v_{out} -the entire voltage across the secondary of the transformer and value of the diode is

IN 5394

2.2.7 FILTERING CAPACITOR SELECTION.

A rectifier circuit is necessary to convert a signal having a zero average value into one that has non-zero average. The output resulting from the rectifier is a pulsating dc and not yet suitable as a battery replacement. Such a voltage could be used in, say, a battery charger, where the average dc voltage is large enough to provide a charging current for the battery for dc supply voltages, as those use in computer and other electronic circuit, the pulsating dc voltage from a rectifier is not good enough. A filter circuit is necessary to provide a steadier dc voltage.

2.2.8 THE BASIC CAPACITOR FILTER.

A most popular filter circuit is the capacitor-filter circuit shown in fig 3.5.1. This is simply a capacitor connected in parallel with the load resistance. The filtering action is based on the charge/discharge action of the capacitor. During the positive half-circle of the input, D1 will conduct, and the capacitor will charge rapidly. As the input starts to go negative, D1 will turn off, and the capacitor will slowly discharge through the resistance. It is the difference between charge and discharge time of the capacitor that reduces the variations in the rectifier output voltage.

2.2.9 EFFECT OF INCREASING FILTER CAPACITANCE

A capacitor has the basic properties of opposing charges in voltages. thus, a high value capacitor will tend to reduce the ripple magnitude, it has been found that increasing the capacitor value tends to:

1. Increase the magnitude of ripple voltage.
2. Reduce the magnitude of ripple voltage.

3. Reduce the time of flow of current pulse through the diode.
4. Increase the peak current in the diode.

The value of reservoir capacitor, C will depend on the load current required and the amount of ripple that can be tolerated. The value shown in the table 2.6.1 should be adequate for most application.

Table 2.2.8. Load current capacitance relationship

NOMINAL LOAD CURRENT	RESERVOIR CAPACITOR
125mA	470 μ f
250mA	1000 μ f
500mA	2200 μ f
1.0A	4700 μ f
2.0A	6800 μ f
4.0A	10000 μ f
8.0A	22000 μ f

2.2.10 VOLTAGE REGULATOR SELECTION

The final circuit in the basic power supply is the voltage regulator. There are many types of voltage regulators. Many of these circuits contain the number of transistor or an integrated circuit (IC) voltage regulator. IC units provide a fixed positive voltage, a fixed negative voltage, or an adjustable set voltage.

In an unregulated power supply, the output voltage changes whenever input voltage or load resistance changes. It is stable, voltage regulation is the change in voltage from no-load to full load condition. The purpose of the voltage regulator circuit is to

reduce this variation to zero or the minimum possible value. The percentage regulation or simply regulation of power supply is given by:

$$\% \text{ Regulation} = \frac{V_{\max} - V_{\min}}{V_{\max}} \times 100 \quad (18)$$

V_{\max} = maximum dc output voltage.

V_{\min} = minimum dc output voltage.

2.2.11 THREE-TERMINAL VOLTAGE REGULATOR

Modern circuitry generally employs an IC voltage regulator to provide the required voltage stability. The simplest voltage regulator, which are adequate for many applications, are three-terminal types. Representatives of the three terminal regulators are devices in the 7800 series.

The 7800 series of voltage regulators are able to provide an output current of up to 1.5A with one a number of fixed output voltages. If excess current or overheating should occur, the IC will shut down to prevent any damage being casual. The output voltage of 7800 series is indicated by the last two figures in the device number.

Thus, the 7812 provide an output voltage of 12V. The 7812 was selected because 12Vdc supply is required for the operation of the automatic pump control unit and its availability

The 7812 schematically represented in fig 3.7.1.0. The fixed voltage regulator has an unregulated voltage, V_{in} applied to one terminal, delivers a regulated output voltage, V_{out} from a second terminal, with the third terminal connected to ground for a particular IC unit, device specification list a voltage range over which the input voltage can vary to maintain the regulated output voltage, V_{out} , over a range of bias current, I_{in} .

2.2.12 THEORY OF WATER CONDUCTIVITY

Water conductivity is a quantitative measure of the ability of water to pass electric current. The ability depends on the movements of ions (dissolved species carrying on electric charge) in the water. Generally, it can be said that, the greater the numbers of ions specific type in water; the greater will be its ability to conduct. It should be noted that conductivity varies with temperature; earlier, Loach Walter (1981), in his book titled "hand book of water purification" second edition. Chapter 3, revealed the conductivity different sources of water. In this report, the conductivity of different sources of water at 25°C are summarized in tabular form.

Table 2.2.11(a) conductivity of different source of water at 25°C

SOURCES	CONDUCTIVITY IN MICRO SECOND PER CM	P.H
Sea water	51,100	7.9
River water	915	7-8
Well water	570	7.3-7.9
Moor land water	150	6.5-7.2
Water from arid zones	1,000-7,000	7.5-8.5

It should be noted that the reciprocal of each of these conductivities, gives the resistivity in mega ohms per cm. For instance, the resistivity of river is 1/915 m ohms/cm. Now for a unit length, the resistance can be evaluated to be 1/915x100 mega ohms = 109KΩ. Generally, treated have less conductivity as compared with untreated water. This is because most of the conducting ions have been removed during the treatment process. Walter Loach is his book title "hand book of water purification" second edition, chapter four page 95, Table 4.3, revealed the conductivity and resistivity of treated water. The fact that water has different mode of treatment, their conductivity also differs. Walter Loach classified the treatment in grades. His work is reproduced below:

Table 2.2.11(b) Lorch purified water grades.

UNIT	GRADE 1 Chemically and biologically pure water	GRADE 2 Chemically pure water with trace organisms	GRADE 3 Purified water with trace dissolved solids and gasses	GRADE 4 Purified water with trace dissolved solids; Si and CO ₂ as feed water
Conductivity in micro second per cm at 20°C	0.055	0.055	2-1	5-2
Resistivity in mega ohms per cm at 25°C	18	18	0.5-1	0.2-0.5

2.2.13 DESIGN PROCEDURES

The sensory module is the combination of upper conductor (i.e. probe) and the CMOS digital ICs. It should be noted that the body of the metal tank is connected to the negative terminal of the dc supply. The sensor is such that it creates a zero resistance path when in contact with the liquid. Thus making the voltage at this point equal to zero (i.e. 0 volt), and thus transmitted low (logic '0') to the IC. When the sensor is not making contact with the water, it creates a high resistance path and allowing the 12V supply to be across it. This is translated as high (logic '1') to the input terminal of the logic IC. The material for the sensor is such that it does not corrode with the liquid so as not to create unnecessary change in material characteristic.

Voltage supply $V_{cc} = 12V$

High level voltage $H = 12V$ (logic '1')

Low level voltage $L = 0.2V$ (logic '0')

The output from these two sensors serves as input to the logic ICs. The two logic ICs are CMOS 4071 and CMOS 4001.

To determine the output at the different IC output terminal, in the designed circuit as a result of input from the sensors, this is illustrated in the figure below :

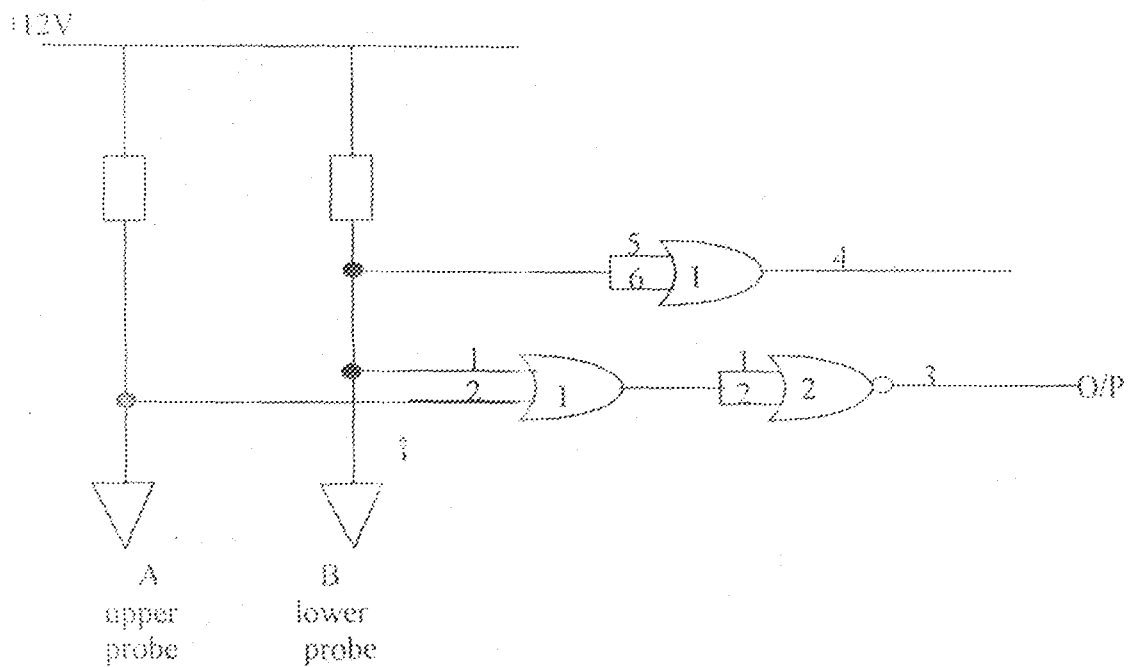

Fig 2.2.12(a) arrangement of the gates

Fig 2.2.12(b) The truth table of fig.2.2.12(a)

A	B	IC1 output terminals.		IC2 output terminal.
		3	4	3
0	0	0	0	1
0	1	1	1	0
1	0	1	0	0
1	1	1	1	0

2.2.14 THE SWITCHING ACTION OF TRANSISTOR Q_1 AND Q_2

1. When the pump is set into operation and the water is below the two probes:

Voltage at probe 1 $V_{p1} = 10V$

Voltage at probe 2 $V_{p2} = 0V$

Output current at output IC1 terminal 3 = 10V

Output current at output IC1 terminal 4 = 10V

Output current at output IC2 terminal 3 = 0V

For the transistor Q1, to get its voltage using voltage divider:

$$V_{B1} = \frac{R_2}{R_1 + R_2} \times 0V = 0V \quad (19)$$

This implies that when the two probes are below the water and the pump is set into operation, the voltage (base voltage) of transistor Q1 at that point is 0V.

For the transistor Q2, to get the base voltage of Q2 at that point we have:

$$V_{B2} = \frac{R_2}{R_1 + R_2} \times 0V = 0V \quad (20)$$

$$= \frac{470}{4.7 \times 10^3 + 470} \times 10V = 0.91V \quad (21)$$

The base voltage of Q2 $V_{B2} = 0.91V$.

And the base current I_{B2} is:

$$I_{B2} = \frac{V_{B2}}{470\Omega} = \frac{0.91V}{470} = 1.93mA \quad (22)$$

The collector current I_{C2} at that point is:

$$I_{C2} = I_{B2} \times \text{current gain} \quad ;$$

Relay 2 is triggered on by I_{C2} following through the coils.

2. When the water touches the lower probe:

$$\text{Voltage at probe 1 } V_{p1} = 0V$$

$$\text{Voltage at probe 2 } V_{p2} = 0V$$

$$\text{Output at } I_{C1} \text{ terminal 4} = 0V$$

$$\text{Output at } I_{C1} \text{ terminal 3} = 10V$$

$$V_{B1} = 0V$$

3. When the water touches the upper probe:

Voltage at probe 1 $V_{p1} = 0V$

Voltage at probe 2 $V_{p2} = 0V$

Output at IC1 terminal 4 = 0V

Output at IC1 terminal 3 = 10V

To get the base voltage V_{B1} of transistor Q1:

$$V_{B1} = \frac{470}{470 + 4.7 \times 10^3} \times 10V = 0.91V$$

$$\text{The base current } I_{B1} = \frac{V_{B1}}{470} = \frac{0.91V}{470} = 1.93mA$$

The collector current $I_{C1} = I_{B1} \times \text{gain}$

With this current (I_{C1}), relay one is energized which causes the normally opened of relay 1 (K_1) to close and as it closes it energizes the K_3 relay which causes the normally close K_1 to open and the pumping action of the motor to the pump stops.

CURRENT FLOWING THROUGH THE LIGHT EMITTING DIODES (LED)

$$I_{LED} = \frac{V}{R} = \frac{12V}{470} = 0.026A$$

2.2.15 ASTABLE MULTIVIBRATOR

Astable multivibration, AMV is a circuit which produces a varying output signal from a dc source. Since the output signal of the AMV is varying, it means that such signal have frequency. Many AMV circuits are in existence. For this particular device an integrated circuit (IC) popularly known as 555 timer is to be used. Simplified internal circuitry (as shown by dotted line) of this IC as revealed by

this book titled "Linear Integrated Circuit", chapter 8, section 8.4 page 341 fig 8 16 is reproduced below:

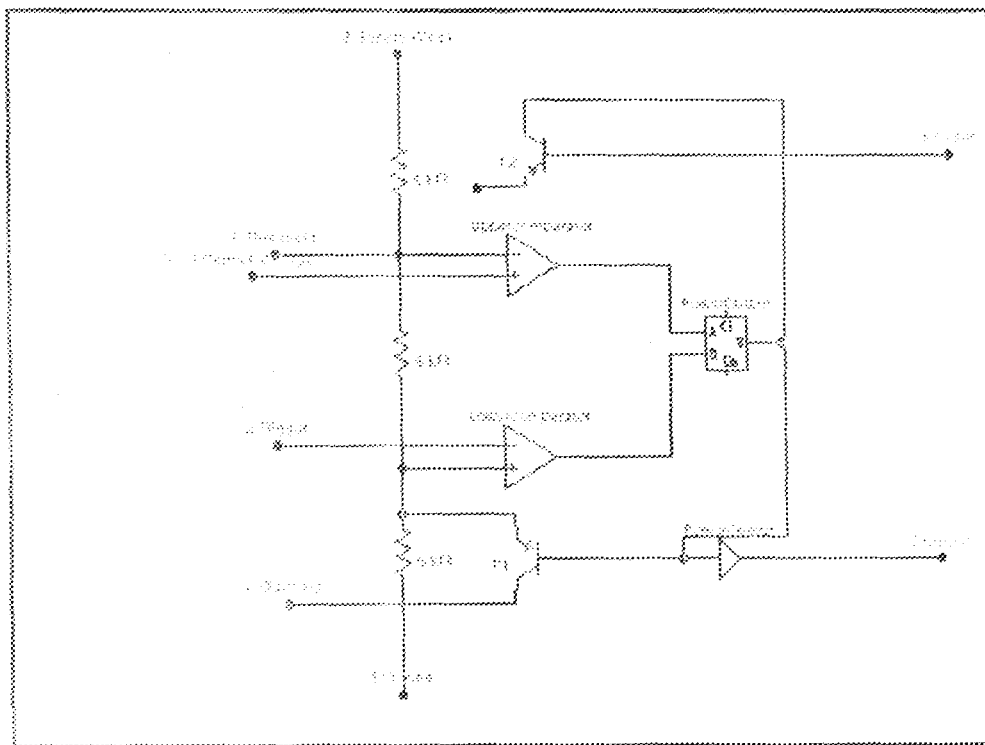

Fig 2.2.11. Functional diagram of multivibrator using 555 timer.

CIRCUIT OPERATION:

With reference to the figure above, when V_{cc} is switch ON, the timing capacitor C starts to charge towards V_{cc} . when its voltage reaches $1/3 V_{cc}$ which is the threshold level of lower capacitor (LC), the output of LC gives high and set the flip-flop, $FFQ = 1$, ($Q = 0$). This produces a positive potential at pin 3 through the power amplifier (inverter). This output is nearly V_{cc} . as the capacitor voltage increased to $2/3 V_{cc}$, which is the threshold voltage of upper comparator UC through pin 6, the UC trigger the flip-flop and reset the FF ($q = 0$, $Q = 1$, pin 3 goes low). Since $Q = 1$, transistor $Q1$ is forward biased and start to conduct. As it conduct, capacitor C starts to discharge through R_B to $Q1$ to ground. Current also flow into transistor $Q1$ through R_A . This

current must be limited to prevent damage to the transistor. The maximum current $Q1$ is $0.2A$. The maximum value should be $V_{cc}/0.2$.

As capacitor discharges to $1/3 V_{cc}$, the LC is triggered setting $S = 1, R = 0$ with FF output $Q = 1, \bar{Q} = 0$. With $Q = 0$, transistor $Q1$ is cut-off and capacitor C starts to charge again while output pin 3 is nearly V_{cc} . That complete one period.

Pin 4 is a reset input, for this particular purpose, it shall be connected to V_{cc} . transistor $Q2$ serves as a buffer to insulate the reset input from the FF and transistor $Q1$. V_{ref} is obtained from V_{cc} internal to drive $Q2$.

Pin 5 is a control pin used to vary the interval. For this particular device, the timing interval will not be varied. Hence, it is recommended by the manufacturers to connected $0.01\mu f$ capacitor between pin 5 and the ground to by-pass noise or ripple from the supply.

CHAPTER THREE

DESIGN, CONSTRUCTION, TESTING AND RESULTS

The designed operation controller is a type of automatic liquid level controller. It is electronically operated to control the level of liquid (water) in a tank. The liquid should be maintained within a certain minimum and maximum level. The design makes use of a simple conductor strands as the sensor probes which together with two logic ICs form the sensory module. The body of the metal tank is connected to the negative terminal of the rectifier circuit. The circuit is powered from the rectifier and well regulated dc power supply. The position of the copper conductor (sensor) with the liquid determines the input voltage level to these two-input digital integrated circuit. The output biases the BC109 switching transistors. A high voltage from the logic gate output switches the transistor into saturation. This serves as the energizing input to the dc relay that puts the circuit into operation as required.

The single phase pump is used in pumping the water at a remote position from the tank into another compartment, as the need arises.

The potentiometers in the circuit are to regulate the sensitivity of the probes with respect to the different liquid used.

3.0 OPERATION OF THE AUTOMATIC PUMP CONTROL UNIT SYSTEM.

There are five levels of operation to be considered

1 When the tank is empty.

2 When the liquid makes contact with lower probe.

3 When the liquid makes contact with the upper probe-when the liquid inside the tank is put into operation (use), stage iv, and v are considered.

4 What operation is / are carried out when the liquid falls below the upper probe (sensor).

5 When it falls below the probe (sensor)

3.0.1. WHEN THE TANK IS EMPTY

When the tank is empty and the switch is ON, the upper and the lower probes are at logic level '1'. Thus, the full 12V at its terminals. This produces a low i.e. '0' at the output of IC₂, hence Q₁ (transistor) is not biased. But the output of IC₁ i.e. terminal 4 is high which biases the Q₂ (transistor) that energizes the K₂ relay. This causes the normally closed contact of K₂ to open.

However, on switching the main switch ON, the supply voltage of 220V is applied to the coil of the motor contactor via the normally closed K₃ auxiliary terminal that energizes it to supply power to the motor terminals that pump water up the tank

3.0.2 WHEN IT MAKES CONTACT WITH THE LOWER PROBE

As the water level increases in the tank it reaches a point where it makes contact with the lower probe. When this occurs, the upper probe is at logic high i.e. '1' and the lower probe is at logic low i.e. '0'. At this stage the output terminal 3 of IC₂ remains low '0' this de-energizes the K₂ relay and the K₂ auxiliary contact goes back to the normally closed position.

3.0.3 WHEN IT MAKES CONTACT WITH THE UPPER PROBE

As the water level rises to make contact with the top probe, both the upper and lower probes at logic '0'. This causes the IC₂ output terminal 3 to go high i.e. '1'. This forward biases the Q₁, transistor to saturation. This passes current to energize the K₁

relay, which also causes the normally opened K_1 auxiliary terminal to close and thus energizing the K_3 relay which in turn opens its normally closed auxiliary contact that supplies the coil of the motor contactor K_m . This action de-energizes the motor contactor K_m and the pumping action of the motor stops.

It should be noted that the output of the IC_1 , is low i.e. at logic '0'.

3.0.4 WHEN THE WATER LEVEL FALLS BELOW THE UPPER PROBE

When the water is put into use and its level falls below the upper, the upper sensor is at logic '1'. This makes the output of IC_2 to go low, but this will not cause K_1 to be de-energized since the current that switches the Q_1 transistor into saturation is retained through the auxiliary contacts K_1 and K_2 . The IC_1 output remains low and the relay K_2 remains as it was in the previous stage.

3.0.5. WHEN THE WATER LEVEL FALLS BELOW THE LOWER PROBE

As the water falls below the lower probe, both the upper and lower probes are at logic high i.e. '1' level. This results in the output of IC_2 to be low, thus not biasing Q_1 . This causes relay K_1 to be de-energized, thus opening the K_1 auxiliary contact which in turn de-energizes K_3 relay. This returns the normally closed auxiliary contact of the relay K_3 back to position and the motor will start working again as a result of energizing the motor contactor relay K_m . At the same time the output of IC_1 is high thus energizing the relay K_2 which opens the auxiliary contact K_2 that causes the discontinuous of supply to the base of the Q_1 transistor.

THE ALARM CIRCUIT DESIGN

The design is incorporated with an alarming system which beeps to indicate the level at which water is in the tank. It is also designed in such that when there is no

water flow or overflow as a result of a fault within the system, the alarm beeps to indicate no water flow. This is so achieved through the following method:

3.1 FOR NO WATER FLOW ALARM CIRCUIT

When there is no water flow as a result of fault within the system, the alarming circuitry beeps to indicate through a light-emitting diode NO-WATER flow. When there is no water flow, all the probes are said to be high i.e they are not in water. This is achieved by connecting the NO-WATER flow probe to pin 6 of a AND gate and also we connect the overflow which is a high to a NOT gate (pin 14) whose output (pin 15) is a low which now goes to pin 12 of an OR-gate and pin 13 of the OR gate is connected to the No-water flow probe which is a high i.e. pin 12 is a low while pin 13 is a high and the output pin 11 of the AND-gate is a high which biases the transistor Q that switches on the alarming circuit whose output pin (3) of the 555-timer is connected to pin (5) of the AND-gate, therefore pin 5 and pin 6 of the AND-gate are high and their output pin (4) is a high which switches on the LED, blinking and indicating No-water flow at a very short time interval. The 555-timers are used so as to enable beep sound at a very short and continuous time interval.

3.2. FOR LOW INDICATING CIRCUIT

When the lower probe is said to be in water, it means that the pump is at work and the lower probe is at logic level '0' and higher probe is at logic level '1'. The lower probe is connected to a NOT-gate (pin7) whose output (pin 6) is a high and connected to an AND-gate (pin 8) The HIGH-probe, which is a high, is connected to pin 9 of the AND-gate, so pin (8) and pin 9 are set to be high and their output (pin 10) is a high, which switches ON the LED indicating a 'LOW'.

3.3. FOR HIGH INDICATING CIRCUIT

When the higher probe is said to be in water, both the lower and higher probes are at logic level '0'. The overflow probe is at logic level '1' (high). The output of IC₂ which is a high, is connected to pin 12 of the AND gate and the over-flow probe, which is a high, is connected to pin 13 of the AND-GATE. The output of the AND-GATE at pins 12 and 13 is pin 11, which is a high, therefore it switches On the LED indicating a HIGH

3.4 FOR OVER-FLOW ALARM CIRCUIT

When the over-flow probe is in water, it means that all the probes (no-water flow probe, lower and higher probes and the over-low probe) are at logic 'LOW'. For the alarming circuitry to come on, the over flow probe is connected to pin 14 of the NOT-gate and the output (pin15) which is a high '1' is connected to pin 12 of IC₁ (OR-gate) which biases the transistor Q that switches on the alarming circuit (555 timer). The output of the alarming circuit pin 3 is a high and connected to pin 1 of the AND-gate. Pin 15 of the NOT-gate is connected to pin2 of the AND-gate. Pin 1 and pin 2 are at logic level high '1'. Their output pin 3 of the AND-gate is at logic level high '1' which switches ON the over-flow indicator (L.E.D) and the alarm start to beep.

3.5. BRIEF DELSCRIPTION OF THE CMOS 4001

In expense of CMOS logic IC₂ like 4001B can easily be used. It is not very expensive but highly versatile clock generator circuits. They can be designed to give symmetrical or non-symmetrical output and can be of running or the gate type. In the later case, they can be designed to turn on with either logic-0 or logic-1 gate signals and to give either a logic-0 or logic-1 output when in the mode. These very

Inexpensive CMOS circuit can even be used as simple voltage controlled oscillators (VCO) or as frequency modulated oscillators.

3.6 EVALUATION OF RELAY COIL SHUNT DIODE

When the energizing current of a relay coil is switched OFF, the energy in the relay coil magnetic field produces a back emf, which in turn could cause a damaging induced current surge through the circuit. To protect the circuit from this damaging effect, a diode is connected in reverse direction with respect to the relay driven polarity, such that, the relay coil dissipates its energy across the diode.

The PIV rating of the diode should be greater than the coil applied voltage (12V). Hence, a diode of PIV = 50V is selected.

3.7. PROTECTION AGAINST SHORT CIRCUIT

A fuse is provided to cutout supply to the load in case of short circuit in the load.

3.8 CONSTRUCTION:-

The circuit was coupled and soldered on a Vero-board as shown in the project layout. During the soldering process, some important consideration were observed. This considerations include the following:

For the fact soldering heat is capable of damaging integrated circuits, IC sockets were used. But due to the fact that the sockets were first soldered before the ICs were inserted, therefore the IC sockets totally eliminate the soldering heat to the ICs.

The casing of the soldered components which makes up a circuit was another aspect of construction. The device was cased in a metal box.

On the case, there are points provided for attaching the power sockets of the pump to the system (switch), audio and visual output devices, power supply LED indicator, ac mains power supply probes and probes PB₁, PB₂, PB₃ and PB₄ and fuse.

The case was further provided with airspaces to enhance cooling of the electronic components.

3.9. TESTING.

The testing of the whole system actually began at the very beginning of the design, right from the circuit diagram even before the circuit components were actually soldered. The testing exercise was carried out on a breadboard. The breadboard provided an opportunity to couple the electronic components without soldering. In addition, an oscilloscope was also used to observe waveforms at some specific nodes. During the testing exercise, modification were necessary due to the absent of designed values of components or unavailability of the components in the market.

3.10. RESULTS.

Every step taking in constructing this project is tested and the result is as desired. The ICs responds to the signal from the sensing elements (probes), the transistor in-turn work in line with the signal produced by the ICs and gives their output results to energize the relays. The relay coil also opened and closed the auxiliary contact as the case may be in order to stop or to start the motor for the pumping process. In a case were the system is inefficient due to occurrence of faults or as a result bad working condition of some of the components used to build up the system, an alarming circuitry is used to check if there is water flow or no flow or even if the system is in a good working condition. This has been put to test and was discovered to work as desired. In short, the desired result is achieved because all the components function as expected.

CHAPTER FOUR

CONCLUSION AND RECOMMENDATION.

4.0 CONCLUSION

An automatic pump control unit system with audio/visual indicators was designed and constructed. The device produced audio and visual indications whenever liquid-level reached the specified level. The ICs responds to the signal from the sensing elements (probes), the transistor in turn work in line with the signal produced by the ICs and gives their output result to energize the relays. The relay coil also opened and closed the auxiliary contacts as the case may be in order to stop or start the motor for the pumping process. As a result of the above operation, the desired result has been achieved. That is, the liquid in the tank is properly been monitored from overflow, dryness, etc

4.1 RECOMMENDATIONS.

It is a known fact that water is capable of making a copper wire to rust, when wire is rusted, the conducting ability is greatly reduced. Since the probes are to be used in water, the need to silver coat the uninsulated part of the wire cannot be over stressed. The fact that, the device may be used to sound a warning, I recommend that the power supply LED must be checked ON to ensure that there is supply to the device. Lastly, the vessel containing the liquid should be firmly fixed to stand to protect the water (liquid) from splashing on to the sensor in case if the vessel is being shaken, as these may cause false sensing.

SCHEMATIC DIAGRAM OF AN AUTOMATIC PUMP CONTROL UNIT SYSTEM WITH AUDIOVISUAL INDICATOR

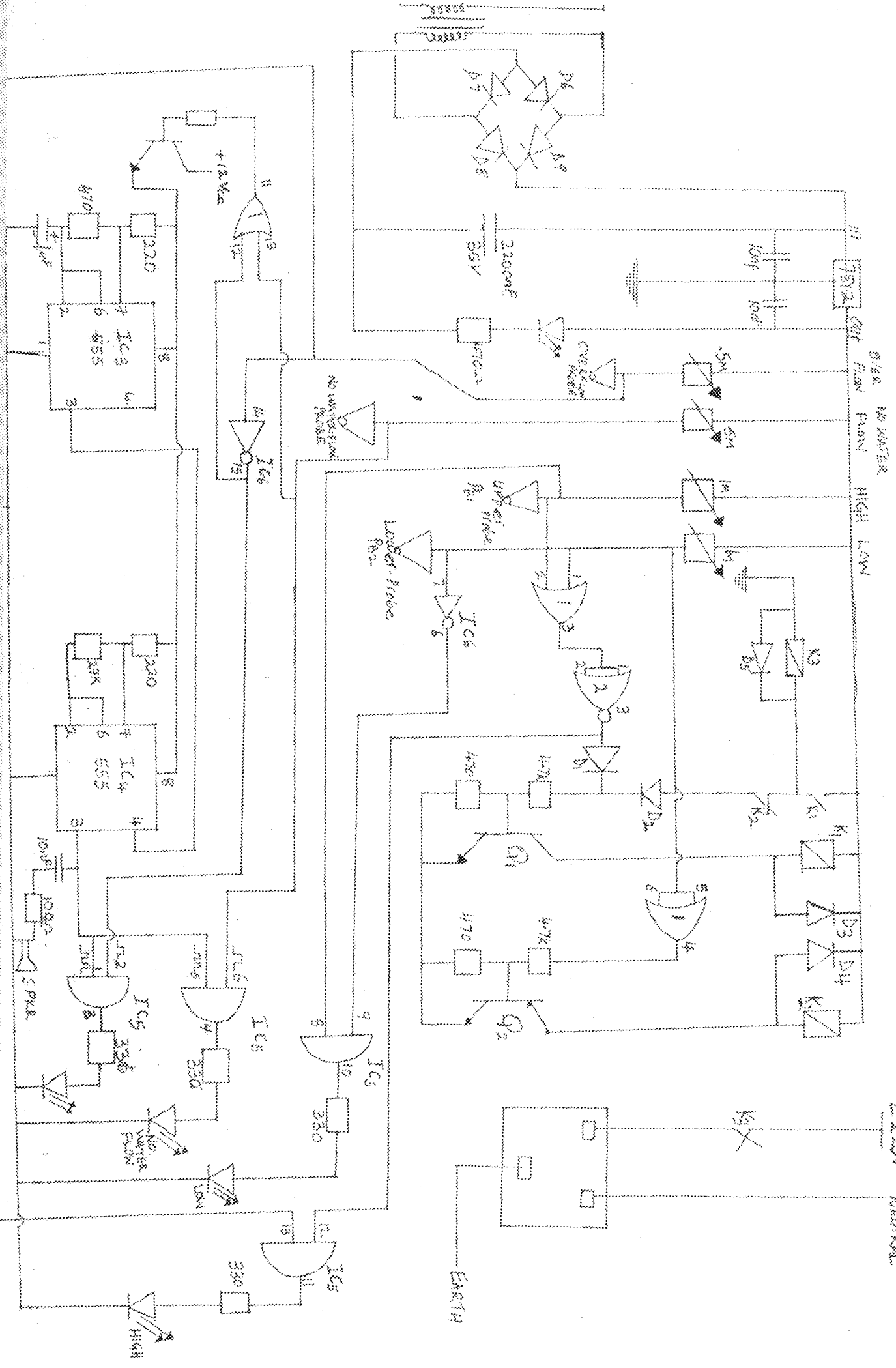

APPENDIX

SUMMARY OF COMPONENTS USED IN CONSTRUCTION

1. 1 NO 220/15V single phase transformer.
2. 5 NO Diodes 1N4001.
3. LED.
- 2 NO. 2.2K Ω preset.
- 2 NO. 4.7K Ω
4. Capacitors
5. Transistors
- 2 NO. T₁ and T₂ BC108
6. Vero-Board
7. 5 NO. IC sockets.
8. 3 NO. 12v Relays.
9. 2 NO. 12V lamps.
10. Resistors.
 - 3 NO. 470 Ω
 - 2 NO. 4.7K Ω
11. 1 NO. 7812 Regulator.
12. IC.
 - 1 NO. IC₁ with pins 8,9,12,13 grounded and 14 +ve
 - 1 NO. IC₂ with pins 5,6,8,9,12,13 grounded and 14 +ve
13. 1 NO. 100 Ω 1.5w loudspeaker.
14. 1 NO. 0.5A fuse.
15. 1 NO. 555 IC timer.

LIST OF REFERENCES

1. WILLIAMS D S OPERATIONAL AMPLIFIERS WITH LINEAR INTEGRATED CIRCUITS. Merrill publishing company A Bell/Howell information company London. 1989-second edition ISBN: 0-675-20660-x pages 253-254

2. LOACH W HANDBOOK OF WATER PURIFICATION Ellis Horwood limited. Market cross-House, copper street, Chichester, West Sussex, PO19 1EB, England. 1981 Second Edition. ISBN: 0-85312-991-6 pages 67-82

2 Brogan F. (1974) semi conductor-Electronics Macmillan-London: 1st Edition PP5, 57, 90, 91

3 D.C green: (1974) Electronics-Tec level IV Pitman London. 2nd Edition PP5, 109, 110, 115

5 Shepherd J; Morton A.H Spence L.F (1970) Higher electrical Engineering. ELBS and pitman-London-2nd Edition page 260-322.