

**DESIGN AND CONSTRUCTION OF FOUR-DOOR  
MONITORING ALARM SYSTEM**

**BY**

**ABDULAZEEZ MUFUTADEEN**

**A THESIS SUBMITTED TO THE DEPARTMENT OF  
ELECTRICAL AND COMPUTER ENGINEERING,  
FEDERAL UNIVERSITY OF TECHNOLOGY, MINNA,  
NIGER STATE,**

**IN PARTIAL FULFILMENT OF THE REQUIREMENT  
FOR THE AWARD OF BACHELOR OF ENGINEERING  
(B. ENG.)**

**NOVEMBER, 2008**

## **DEDICATION**

I dedicate this project to Almighty God for being my guide throughout my research that has finally culminated in this feasible piece of work. May His blessing continue to be my strength (Amen). Also to my late sister Mrs. Simbi Abdulazeez may God bless her soul in paradise (Amen).

## DECLARATION

I, ABDULAZEEZ MUFUTAUDEN with matriculation number 2004/20877EE declare that this work was done by me under the supervision of Mr. J. A. Ajiboye and has never been presented elsewhere for the award of degree. I also relinquish the copyright to the Federal University of Technology, Minna.

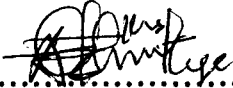

.....  
**ABDULAZEEZ MUFUTAUDEN**  
(Student)

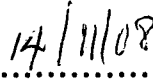

.....  
**Date**

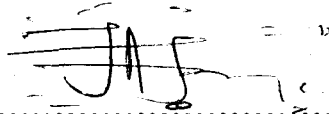

.....  
**MR. J. A. AJIBOYE**  
(Supervisor)

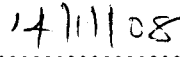

.....  
**Date**

.....  
**ENGR. DR. Y. A. ADEDIRAN**  
(Head of Department)

.....  
**Date**

.....  
**External Examiner**

.....  
**Date**

## ACKNOWLEDGEMENT

I give thanks to Almighty God for His divine inspiration, care, love and guidance and His infinite mercy saw me through the end of my degree programme in Federal University of Technology, Minna.

I would like to acknowledge the effort of my supervisor, Mr. J. A. Ajiboye for his intellectual support and encouragement in making this project a reality.

Special thanks goes to my parents, Mr. Abdulazeez Adeniyi and Mrs. Abdulazeez S. Adepete for their financial, prayer, advice and moral support towards my educational development (May Allah replenish your pockets).

My appreciation goes to my Head of Department, Engr. Dr. Y. A. Adediran and ever dynamic lecturers.

My gratitude also goes to Miss R. A. Sanusi who stand by me financially and morally given to me before, during and after the completion of this long time journey (May Allah reward you abundantly).

Conclusion will not be reached if mention is not made of my sisters and brothers, Fatimat, Aminat, Luqman, Sikiru, Wasiu, Saidi, Mr. K. Muhammed, Mr. Y. A. Awoye and Mr. J. Ismail and most especially the backbone of my academic pursuit, Mr. R. A. Abdulazeez, may Allah bless you all.

And finally, my special thank goes to my bosom friends Abdurashed, Rafiu, Amidu (Chairman), Sarafa, Nuru, Amidu (Aro), Fatai, Fasilat Oyinda who in one way or the other contributed towards the success of this project work.

## ABSTRACT

This project was carried out with the aim of design and construction for four-door monitoring alarm system which detects the present of an intruder into a defined area. It is an integrated security system which can be connected to door handles. It comprises of fire units which integrate to function as a single electronics security system. These units are the power unit, trigger with control units alarm unit and display unit. This integrated system uses monostable multivibrators which detects the high and low of anyone of the monostable pins and triggers the alarm unit to produce a large audible sound as well as display unit which display the number corresponding to the door handle turned at a time.

## TABLE OF CONTENTS

Title Page.....	i
Declaration .....	ii
Dedication.....	iii
Acknowledgement.....	iv
Abstract .....	v
List of figures .....	vi
List of tables.....	vii

### CHAPTER ONE: INTRODUCTION

1.1 General introduction .....	1
1.2 Project objectives.....	2
1.3 Methodology.....	3
1.4 Scope of project.....	3
1.5 Source of materials.....	3
1.6 Project outline .....	3

### CHAPTER TWO: LITERATURE REVIEW

2.1 Historical development of alarm systems.....	5
2.2 Modern electronic alarm systems .....	6
2.2.1 Industrial alarm systems.....	6
2.2.2 Professional burglar alarm system.....	7
2.2.3 Duress alarm system.....	8
2.2.4 Speed limit alarm system.....	9
2.2.5 Anti-theft car alarm system.....	9
2.3 Advancement in alarm sensor technology.....	

**CHAPTER THREE: DESIGN AND IMPLEMENTATION**

3.1 Circuit design and analysis.....12

3.2 The power supply unit.....13

    3.2.1 Operation of the power supply unit.....13

3.3 The trigger unit.....16

3.4 The control unit.....18

3.5 The alarm unit.....20

3.6 The display unit.....22

3.7 The circuit unit.....23

**CHAPTER FOUR: CONSTRUCTION AND TESTING**

4.1 Case construction.....26

4.2 Testing and results.....27

4.3 Discussion of results.....28

4.4 Problems encountered.....29

4.5 Troubleshooting guide.....30

**CHAPTER FIVE: CONCLUSION AND RECOMMENDATION**

5.1 Conclusion.....31

5.2 Recommendation.....31

References.....32

Appendix.....33

## LIST OF FIGURES

3.1	Block Diagram of four-door monitoring alarm system.....	12
3.2	Schematic diagram of the power supply.....	13
3.3.1	Pin-out of the 555IC.....	16
3.3.2	Circuit diagram of the trigger unit.....	17
3.4.1	Circuit diagram of the Control unit.....	19
3.5.1	Circuit diagram of the Alarm unit.....	20
3.6.1	Circuit diagram of the Display unit.....	22
3.7.1	Circuit diagram of the entire system.....	24
4.1	Project main casing.....	25



**LIST OF TABLES**

3.4.2 Truth table for the gating function of the control unit..... 18

3.6.2 Seven segment code conversion table.....23

# CHAPTER ONE

## INTRODUCTION

### 1.1 GENERAL INTRODUCTION

Alarm systems are systems which operate a warning device after the occurrence of an abnormal or dangerous condition. Today, the insecurity and crime constitute some of the major problems facing our immediate society. People live with fear of being attacked by thieves, vandals and burglars. Despite all the effort, resources and time that has been devoted to the development of tools that will reduce crime rates and make the world a safer place to live, these problems are still on the increase.

These gave rise to the need for an increasing development in the technology of alarm systems which utilizes various principles such as infrared motion detection, light (photo) sensitive electronic devices and so on. Even into the introduction of these alarm systems which have reduced greatly the level of insecurity and crime; there is still a problem of false alarm which needs to be minimized [1]. In order to effectively reduce the level of insecurity and avoid false alarms which can create unnecessary unrest, a monitoring security system is required. This system if properly designed will provide security and ensure alarms are activated only when an unauthorized person try to gain access to the protection area or device by turning the knob or any other part of the device serve as the entrance.

These are some of the reasons that prompted the design and construction of the four door-monitoring alarm system presented in this work.

The system presented by this project work consist of five basic units viz:

- i) The power supply unit which employs the use of mains supply to ensure constant power supply to the circuit.
- ii) The alarm unit which produces amplitude alarm sound when triggered by the trigger unit with the aim of producing a large audible sound that can scare an intruder away and alert the entire neighbourhood.
- iii) The display unit is made of seven segment display each with a transistor switch which can be displayed when alarm is ringing.
- iv) The trigger unit which is responsible for activating the alarm unit. This unit was designed to have a lot of time and period and moderate sensitivity in order to reduce the rate of false alarm and
- v) Control which is responsible for the controlling the entire circuit is made of TTL Quad 2-input OR gate. The output of the trigger circuit is also fed into this unit.

## 1.2 PROJECT OBJECTIVES

This project "Design and construction of a four door-monitoring alarm system" was carried out with the aim of meeting the following objectives.

- a) To develop a security system that will check the increasing activities of burglars, thieves and vandals thereby reducing crime rate in the society.
- b) To develop a cheap and reliable means for raising alert in the event of unauthorized intrusion to residential and commercial buildings.
- c) To produce a cheap and reliable means of monitoring all the activities in and around all the entrances.
- d) To develop an alarm system with reduced rate of false alarm.

- e) To produce a portable security system that has multiple applications.
- f) To avoid misuse and tampering with the doors by the intruders.

### **1.3 METHODOLOGY**

The method applied is the gating principle. Each door is connected to a normally open push button switch. The normally open switch is connected to supply voltage through a pull-up resistor and also connected to the ground. When the switch is open, the pin 2 (trigger) of the 555 monostable multivibrator is HIGH and the multivibrator is not triggered. When the switch is closed by turning a knob, the trigger pin 2 goes LOW and the monostable multivibrator output a HIGH for one minute.

### **1.4 SCOPE OF PROJECT**

The project utilizes the basic operation of monostable multivibrator in the trigger and alarm circuit. The multivibrators are used to ensure that the alarm unit is only triggered when an intruder try to gain access to the protected area or device. The entire construction was manually done, using tools and equipment available within the immediate environment and tested with the available measuring instruments.

### **1.5 SOURCE OF MATERIALS**

Information that aid the successful design and construction of monitoring alarm system were sourced from various sources including internet, text books and past lecture notes in analogue and digital electronics and consultation with colleagues who offer useful suggestions.

### **1.6 PROJECT OUTLINE**

This project focuses on the design and construction of a four door monitoring alarm system.

Chapter one deals with the introduction of the four-door monitoring alarm system. aims and objectives of the present design, methodology, scope of project, source of materials and project outline.

Chapter two contains the literature review, historical development, modern electronic alarm systems and advancement in alarm sensor technology.

Chapter three focuses on the system design, its analysis, relevant calculations and implementation.

Chapter four explains the testing, results obtained and implementation of the project work.

Chapter five presents the conclusion of the work, summary and problems encountered as well as recommendation for future references.

## CHAPTER TWO

### LITERATURE REVIEW

#### 2.1 HISTORICAL DEVELOPMENT OF ALARM SYSTEMS

An alarm system is a system which operates a warning device or signal for alerting or informing people of danger or problem. An alarm system is thus a security system that produces a form of sound to warn people of a particular danger. The development of alarm systems started with the creation of man. Man required giving alert, information and adopted a form of signaling, exclamation and shouting. This was later replaced by clapping of hands and beating of gongs by town criers to alert the community in order to disseminate information in the early African society. All these methods of raising alert were crude, unreliable and inefficient.

With the advancement of science and technology, these crude methods of generating alarm were replaced by electronic alarm systems in the late eighteenth century [1]. These electronic alarm systems operate without any human effort. once it senses a particular signal, it gives an indication in form of loud sound or noise depending on its design [1].

The first electronic fire alarm system was developed by Dr. William F. Channing and constructed by Mr. Moses G. Farmer, an electrical engineer [2]. This system uses boxes with automated signaling to indicate the location of fire and was first put into operation in Boston in the United State of America (U.S.A.).

The development of this alarm system by Dr. William was followed with the evolution of fire and burglar alarm technology of varying complexities and sophistication which are too numerous to mention [2]. Notable among these

technologies is the remote signaling intruder alarm system which was invented in the early 1970's [3]. This provided a rapid art full response to alarm calls.

The security industry is constantly evolving to come up with new and innovative techniques to keep off burglar and vandals [3]. Today, we have the new generation of electronic alarm system which comes in various levels of complexities and sophistication [4]. These are usually called the modern electronic alarm system.

## **2.2 MODERN ELECTRONIC ALARM SYSTEMS**

With the recent increase in crime rates, it has become important to protect our buildings and properties with adequate safety devices with increased level of sophistication [5].

The cost of these safety devices depend on the equipment technology and the application requirement. These safety devices are called the modern electronic alarm system [5].

Some of the modern alarm systems commonly used these days is burglar alarms duress alarms, industrial alarms, speed limit alarms and anti-theft car alarms.

### **2.2.1 Industrial Alarm System**

These alarms come in three versions. The 12V dc Grey bell is affordable and suitable for home security. It complies with the requirements of BS4737 intruder alarm system in building [6]. The unit is mounted within a bell enclosure when used in external environments for fire detection. The 240V ac Grey bell is an extremely effective signaling unit for use in industrial environments. The design avoids the need for mechanical contacts resulting in greater reliability and efficiency and longer operating life. The units may be

ceiling or wall mounted with flush or surface wiring and requires no final setting up adjustment. A chip holds the movement to a high polycarbonate base and a twist lock mechanism holds the gang in position [7].

### **2.2.2 Professional Burglar Alarm System**

These usually involve a circuit loop system that rings a bell or activates a siren when set off. A central control box monitors several motion detectors and perimeter guards and sound an alarm when any of them are triggered. Some burglar alarms work on the concept of magnetic contacts and others on sensitivity. Sensors are placed in the hallways or large rooms which activate an alarm when the beam of light is interrupted by a person walking across it [8]. Motion detection is also carried out by ultrasonic means. Point detector burglar alarm brings to notice any intrusion at a specific point such as doors or windows. Area detection of intruders is done within a protected area with the help of ultrasonic transducers and passive infrared sensors, (IR) sensors which are usually mounted at an appropriate location. The sensors can be used individually or in combination depending on the kind of burglar alarm sophisticated desired [8].

Nowadays, closed circuit televisions are incorporated to burglar alarms to detect the presence of unauthorized persons. The output of burglar alarm systems can range from siren or loud alarms to telephone automatic dialers and flashing out door light. This serves the function of alerting the neighbors of possible intrusion and also serves as a signal to the police. Auto dialers attached to burglar alarms are programmed to dial the police and play a pre recorded message that informs the police of the house being burgled. [9].



### 2.2.3 Duress Alarm System

Modern duress alarms are generally electronic devices that very widely capabilities. They are used when under threat to send alarm signals to specific location, there are three general overlapping categories of duress alarms that can send one or more levels distress signals to a particular location [9]. The types of duress alarm systems are:

- i) Identification alarm: A portable device that identifies the owner of the device.
- ii) Panic button alarm. A push button mounted in a fixed location.
- iii) A location alarm: A portable device that locates and tracks the person who activate alarm.

The panic button is the most common type of duress alarm. It is found in schools, banks, offices, etc. the simplest application is a strategically located button that when initiated would engage a dedicated phone line. A pre-recorded message specifying the location an urgency is sent to several locations such as police department or other security agencies [10].

The identification alarm incorporates a pager-like device that has a panic button built in and is either worn by the user or installed within a foot switched located under a desk. When the panic button is pushed, a wireless signal is transmitted to the nearest installed wireless repeater unit, which sends the signal to an alarm console. The personnel at console receive a coded number and this number would correspond to the user. This system does not give specific locations other than the general pre programmed zone of the repeater.

The location alarm is a similar version of the identification. It can identify, locate and track the person who activated the duress alarm of his or her

pager. The electronics and software of such a system produces a positioning symbol on a console panel or map like display [11].

#### **2.2.4 Speed Limit Alarm Systems**

These are wireless portable devices adaptable with most internal combustion engines. The circuit is designed to alert the vehicle driver when he has reached the maximum speed limit. It eliminates the needs to look at the speedometer and tachometer thereby reducing the risk of accident while driving. It monitors the revolution per minute (RPM) and starts giving a beep when the maximum speed is attained [11].

#### **2.2.5 Anti Thief Car Alarm Systems**

This type of alarm system is usually mounted within the car where it will practically be inaccessible to intruders. The switch can be placed under the dashboard, or under the driver's seat. When the switch is activated or turned on, the electrical system of the car ceases to function or fuel supply is cut off [12].

### **2.3 ADVANCEMENT IN ALARM SENSOR TECHNOLOGY**

The increasing development in science and technology have given rise to a tremendous improvement in the technology of alarm sensors. These sensors act as input which triggers the alarm. Some of the alarm sensor technologies that have evolved over the years are:

- a) **Microwave sensors:** These are motion detection devices that flood a designated area or zone with an electronic field. A movement in the zone or area disturbs the field and sets off the alarm [12].
- b) **Vibration Sensors:** The vibration sensors are usually mounted on walls, ceiling and floor with the intention of detecting mechanical

vibrations caused by chopping, sawing, drilling or any type of physical intrusion. [13]

- c) Photo electric beam sensor: These sensors transmit a beam of infrared light to a remote receiver thereby creating an electronic fence. These sensors are often used to cover openings such as door ways or hall ways acting essentially as trip wire. Once the beam is broken or interrupted, an alarm signal is generated [13].
- d) Passive ultrasonic Sensor: These are motion detection sensors that listens for ultrasonic sound energy in a protected area and reacts to high frequencies associated with intrusion attempts.
- e) Active infrared sensor: These sensors generate a certain pattern of modulated infrared energy and react to a change in the modulation frequency or an interruption in the received energy. Both of these occurrences happen when an intruder passes through the protection zone [14].
- f) Electrical field sensors: These sensors generate an electrostatic field between and around an array of conductors and an electrical ground. They detect changes or distortion in the field. This can be caused by anyone approaching or touching the sensor [15].
- g) Audio sensors: These sensors respond to noise generated by intruders entry into a protected area and are generally used but exclusively for internal application.
- h) Capacitance sensors: These sensors detect changes in electric field. A signal is generated when an intruder changes the

capacitance of the field by approaching or contacting the sensor's wire [15].

The alarm sensor technology employed in this project work is the capacitance sensor. The sensor's wire is usually attached to metallic door handles and protectors etc. It normally require touch or close proximity and subsequent alteration of capacitance to trigger the alarm. This alarm sensor was adopted for this project work because it reduces the production of false alarms due to the fact that the sensor's detection ability is not affected by weather, electromagnetic and radio frequency interference.

## CHAPTER THREE

### DESIGN AND IMPLEMENTATION

#### 3.1 CIRCUIT DESIGN AND ANALYSIS

In order to meet the objective of this project, the entire system design is divided into the following units:

1. The power supply unit,
2. The trigger unit
3. The control Unit
4. The alarm unit
5. The display unit

The block diagram is shown in the figure below:

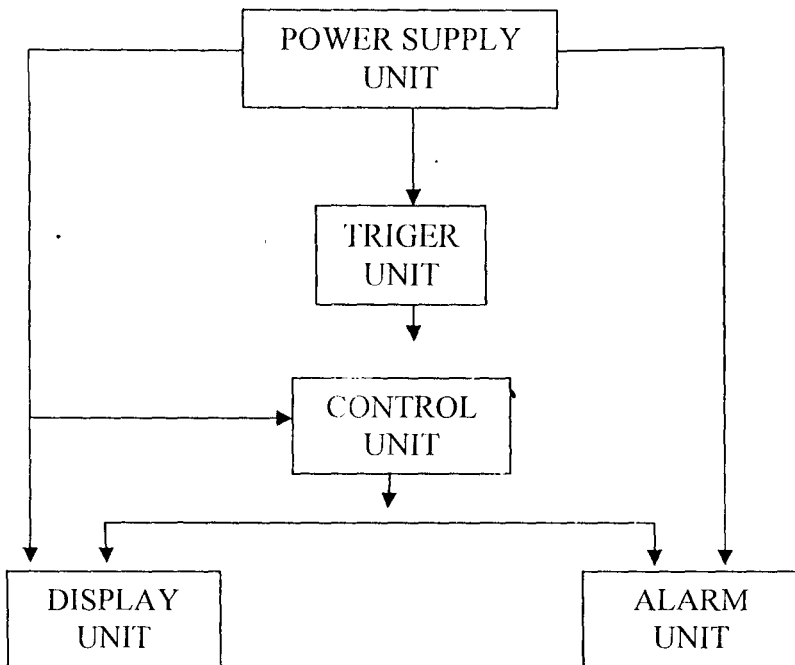

Fig. 3.1 Block diagram of four-door monitoring alarm system

## 3.2 THE POWER SUPPLY UNIT

The power supply unit consists of a transformer, four diodes, three capacitors and two voltage regulators. The power supply unit is meant to take an a.c power from the mains, step down the voltage, rectifies the a.c. voltage into a d.c. and regulate the d.c. to enable the power drives the circuit.

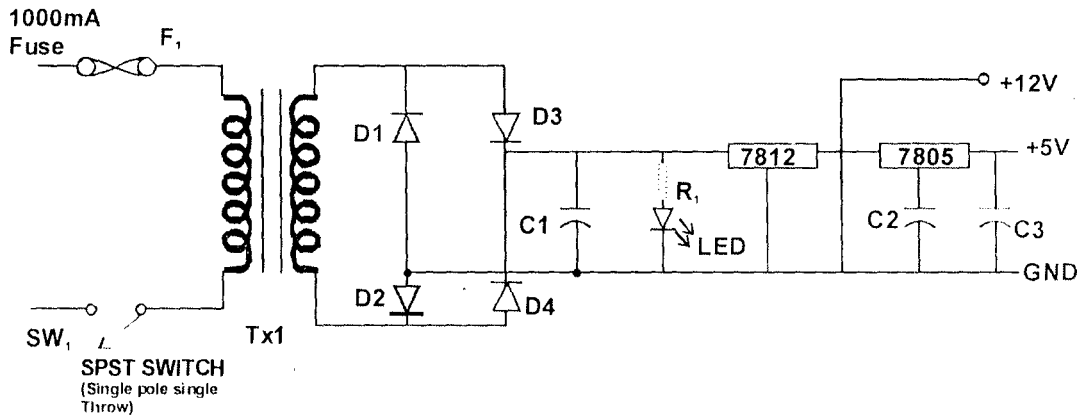

Fig. 3.2. Power supply circuit.

### 3.2.0 OPERATION OF THE POWER SUPPLY UNIT

The operation of each stage of the power supply unit can be described below:

### 3.2.1 VOLTAGE TRANSFORMATION

The voltage transformation was achieved using a step-down transformer with specification given below:

$$\text{Primary voltage, } V_p = 230\text{V rms}$$

$$\text{Secondary voltage, } V_s = 15\text{Vrms}$$

$$\text{Secondary current, } I_s = 500\text{mA} = 0.5\text{Arms}$$

Using the transformer equation, [4]

Using the transformer equation,

$$\frac{V_p}{V_s} = \frac{I_s}{I_p} \quad (3.1)$$

$$I_p = \frac{V_s \times I_s}{V_p}$$

$$\frac{15 \times 0.5}{230} = 0.0326 A$$

$$= 32.6 \text{mA rms}$$

Also,

$$V_{peak} = \sqrt{2} \times V_{rms} \quad (3.2)$$

$$= \sqrt{2} \times 15 = 21.21 V$$

$$I_{peak} = \sqrt{2} \times I_{rms} \quad (3.3)$$

$$= \sqrt{2} \times 0.5$$

$$= 0.707 A$$

### 3.2.2 VOLTAGE RECTIFICATION

Four IN 4001 were used in the design as voltage rectifiers. They are four diodes connected in bridge circuit. The diodes are designated – D<sub>1</sub>, D<sub>2</sub>, D<sub>3</sub> and D<sub>4</sub>. At the positive half cycle, the current flows through D<sub>3</sub> to the load and back to the supply through D<sub>2</sub>. At the negative half cycle, the current passes through D<sub>4</sub> to the load then back to the supply through D<sub>1</sub>.

The DC voltage is calculated as shown below:

$$V_{dc} = \frac{\sqrt{2} \times V_{peak}}{\pi} \quad (3.4)$$

$$V_{dc} = \frac{\sqrt{2} \times 21.21}{\pi} = 9.55V$$

### 3.2.3 VOLTAGE REGULATION

The system needs two different voltage levels – 5V and 12V. Two positive voltage regulators were used. The regulators are LM7812 for 12V and LM7805 for 5V. The conditions for working of the regulators are:

1. The input voltage should be 3V more than the rated output voltage otherwise the output voltage will be less than the rated value.
2. Excess power is dissipated as heat, therefore, the regulators may need heat sinks.

### 3.2.4 VOLTAGE FILTERING

To meet up with the input requirement of the voltage regulators, voltage filters were needed. To smoothen the pulsating DC obtained from the diode rectifiers. The filter is made of capacitors –  $C_1$ ,  $C_2$  and  $C_3$ .

The capacitors ratings are:

$$C_1 : 2200\mu F/25V$$

$$C_2 : 1000 \mu F/16V$$

$$C_3 : 470\mu F/16V$$

## 3.3 THE TRIGGER UNIT



The major component in this unit is the 555 IC. The pin-out of the IC is shown below:

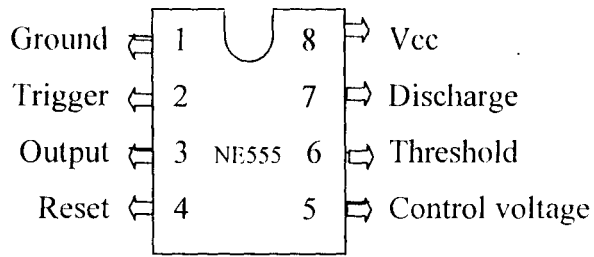

Fig. 3.3. Showing symbol of the 555IC

The trigger unit is made of four monostable multivibrator circuits each being triggered by a key corresponding to one of four doors. The circuit is shown below:

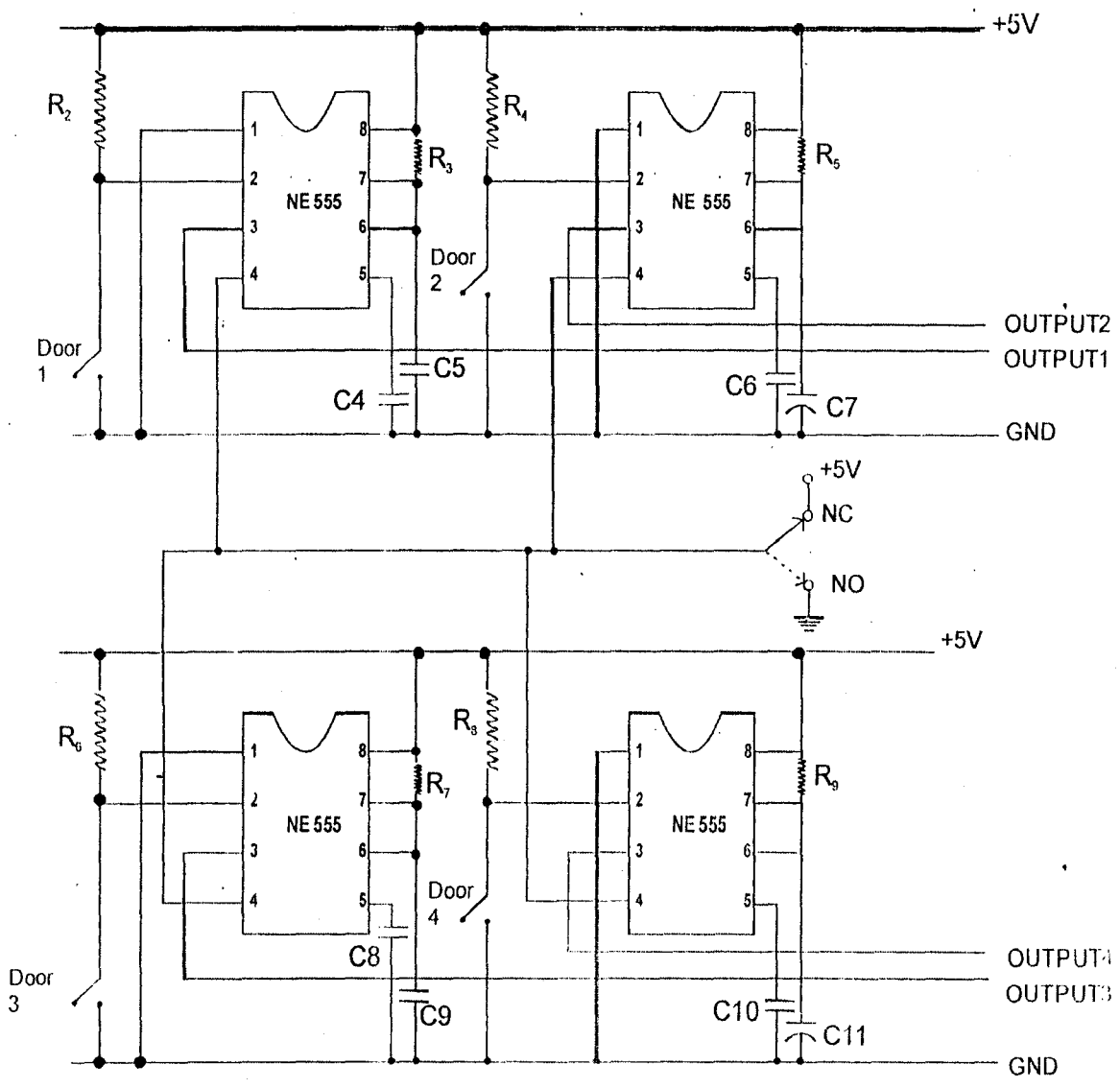

Fig. 3.4 Circuit Diagram of the trigger unit

Picking one monostable circuit and explaining suffices for explanation of the remaining three.

The formula to determine the HIGH time is given by

$$T = 1.1XR_1C_1 \text{ (in Seconds)} \tag{3.5}$$

Where t is the HIGH time,  $R_1$  is the resistor between pin 8 and pin 7 and  $C_1$  is the capacitor between pin 6 and ground.

$$R_1 = R_3 = R_5 = R_7 = R_9 = 1M\Omega^2 = 1 \times 10^6 \Omega$$

$$C_1 = C_5 = C_7 = C_9 = C_{11} = 47\mu F = 47 \times 10^{-6} F$$

$$t = 1.1 \times 10^6 \times 47 \times 10^{-6}$$

$$t = 51.7 \text{ sec}$$

$$t \approx 1 \text{ min,}$$

$$F = 1/t = 1/57.7$$

$$= 0.018 \text{ Hz}$$

This means that when any key/door is closed, the corresponding monostable multivibrator outputs is high for 1 minute.

### 3.4 THE CONTROL UNIT

This is made of TTL Quad 2-input OR gate. The four outputs of the trigger circuit are fed into this system of gates to gate a single final output. The circuit is shown below:

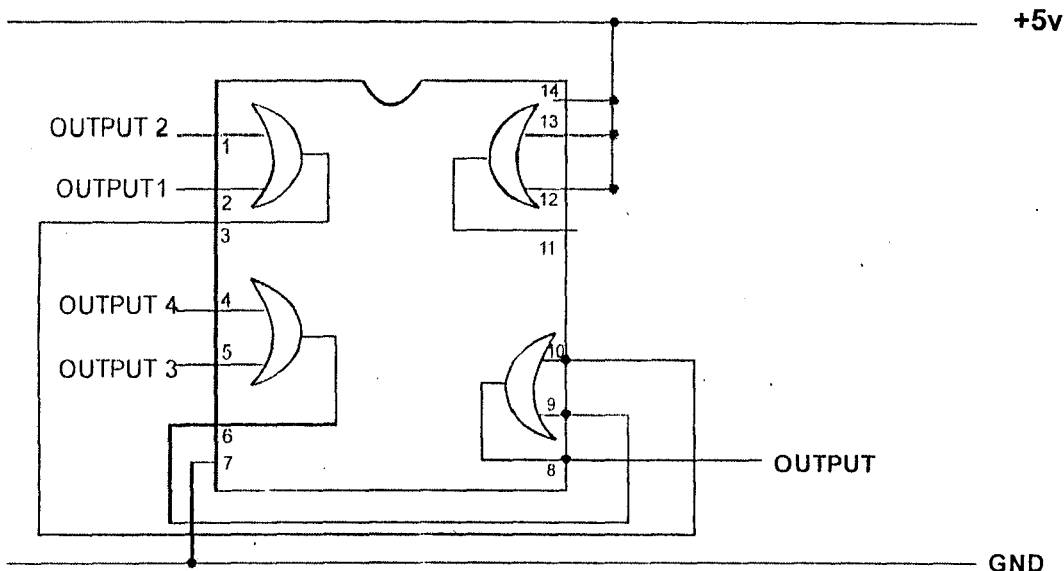

Fig. 3.5 Circuit Diagram of the control unit

The truth table for the gating function of the control unit is shown below:

Table 1.0 showing gating function of the control unit

Output 1	Output 2	Output 3	Output 4	Final output
0	0	0	0	0
0	0	0	1	1
0	0	1	0	1
0	0	1	1	1
0	1	0	0	1
0	1	0	1	1
0	1	1	0	1
0	1	1	1	1
1	0	0	0	1
1	0	0	1	1
1	0	1	0	1
1	0	1	1	1
1	1	0	0	1
1	1	0	1	1
1	1	1	0	1
1	1	1	1	1

What the truth table implies is that the final output is only low when all inputs are low otherwise its high.

### 3.5 THE ALARM UNIT

This circuit is made using 555 IC(s) configured as astable multivibrators. The first IC produces the sound while the second one only gates through the sound. Hence the sound is heard at some time and silent for some other time depending on the HIGH and LOW times of the second astable multivibrator.

The circuit diagram is shown below:

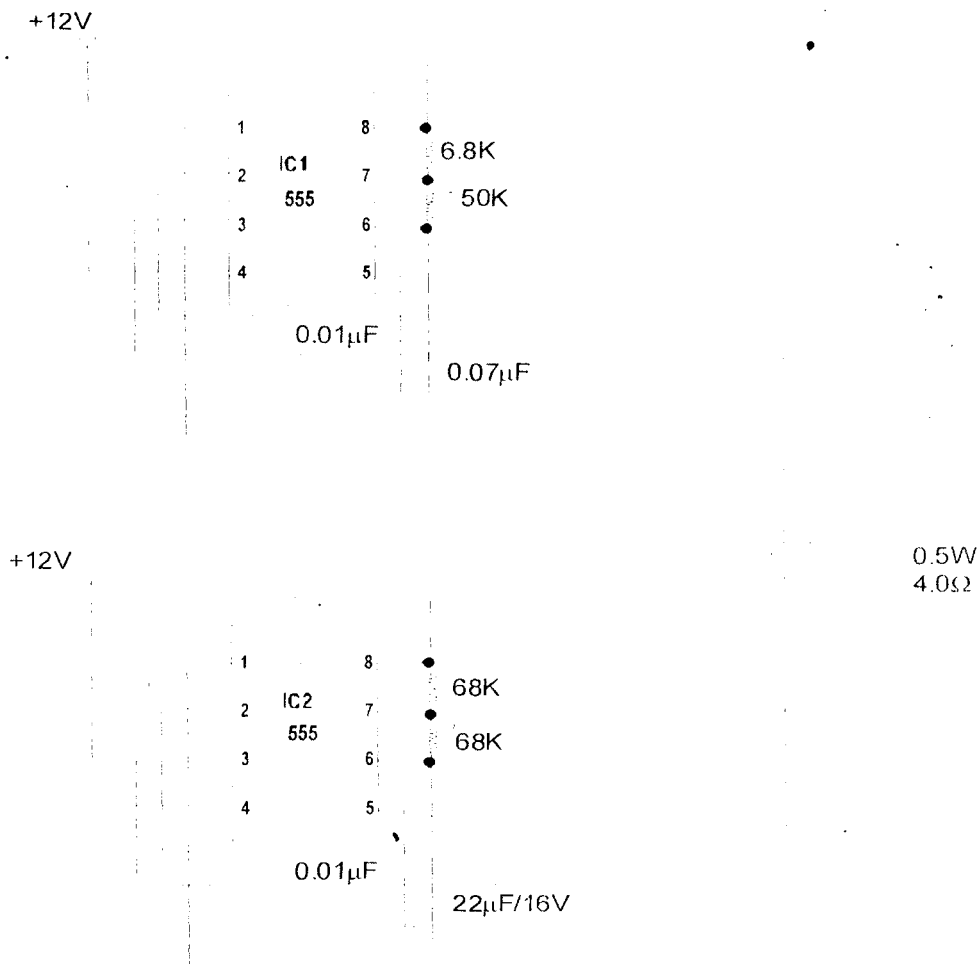

∴ Fig. 3.6 Circuit diagram of the alarm unit

The frequency of the sound (output of the first astable multivibrator is

given as

$$F = \frac{1}{0.693(R_1 + 2R_2)C_1}$$

$$F = \frac{1}{0.693(6.8K + 2 \times 50K)0.01\mu F}$$

$$F = \frac{1}{0.693 \times 106.8K \times 0.01\mu F}$$

$$F = \frac{1}{0.693 \times 106.8 \times 10^3 \times 0.01 \times 10^{-6}}$$

$$F = 1351\text{Hz or } 1.35\text{KHz}$$

This is the audio frequency.

To calculate the HIGH time  $t_1$  and LOW time  $t_2$  of the second astable multivibrator,

$$t_1 = 0.693 (R_1 + R_2) C_1$$

$$= 0.693 (68K + 68K) 22\mu F$$

$$t_1 = 0.693 \times 136 \times 10^3 \times 22 \times 10^{-6}$$

$$t_1 = 2.07\text{sec}$$

$$t_2 = 0.693 (R_2) C_1$$

$$t_2 = 0.693 \times 68K \times 22\mu F$$

$$= 0.693 \times 68 \times 10^3 \times 22 \times 10^{-6}$$

$$t_2 = 1.04 \text{ sec.}$$

### 3.6 THE DISPLAY UNIT

This unit is made of four seven segment displays each with a transistor switch

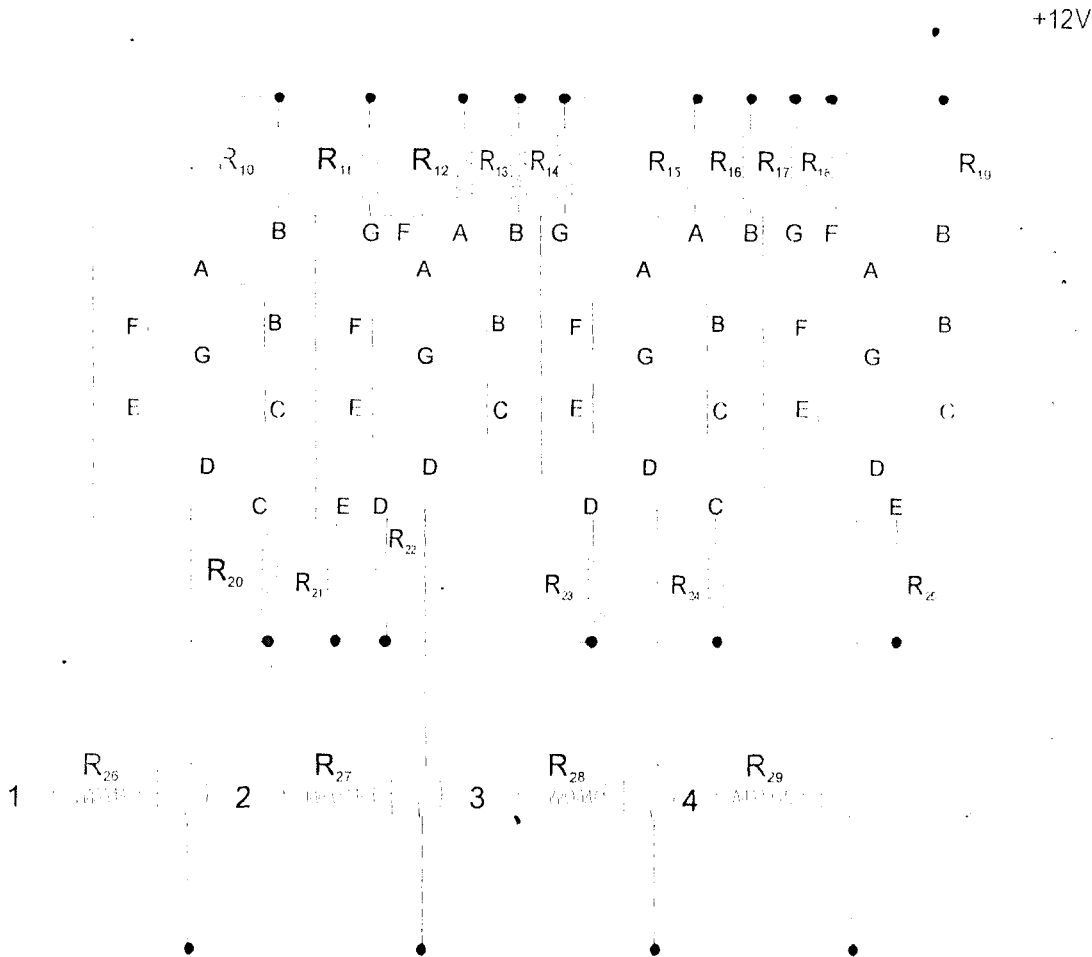

Fig. 3..7. Circuit diagram of the display unit

$R_{10} = R_{11} = R_{12} \dots = R_{29} = 220\Omega$  when a door knob is pressed/key closed, the output of the monostable multivibrator connected to that door goes HIGH. The base of the transistor controlling the seven segment display corresponding to this goes HIGH and the seven segment display connected to display the number corresponding to this door goes on. This same output of the monostable is fed to the control unit quad two-input OR gate system. At least, one of the inputs is HIGH, so the output of this system goes HIGH and

circuit goes on. The duration for each display is approximately one minute and the duration for ringing is at least one minute. If another key is closed, the seven segment display corresponding to that door goes on to last for another one minute and not affecting the last display but the ringing circuit is effect only continues the last ringing to make up a new one minute without an interest to complete the last one minute. Below is the truth table on configuration:

Table 1.1: seven segment code conversion table

Door	Seven segment equivalent						
Numbers	a	b	c	D	e	f	g
1	0	1	1	0	0	0	0
2	1	1	0	1	1	0	1
3	1	1	1	1	0	0	1
4	0	1	1	0	0	1	1

### 3.7 CIRCUIT OPERATION

The complete circuit diagram of the security system is shown in Fig. 3.7.1 The system uses four 555 monostable multivibrators. When the knob of door one is turned, monostable one is triggered and pin 3 (output pin) of the monostable goes HIGH and stays in this state for one-minute as determined by the R and C values of the monostable. The process is the same for the other three monostable multivibrators. The outputs of the four multivibrators are connected together through quad two-input OR gates in TTL 7432 IC. The output of this IC controls the ringing circuit and each output of the monostable



When the circuit is first switched ON, a false alarm may be experienced for the first one minute of its operation. To instantly get rid of this false alarm, a NO/NC 3 input switch is pressed. This resets all the monostable multivibrators. The circuit diagram of the entire system is shown below:

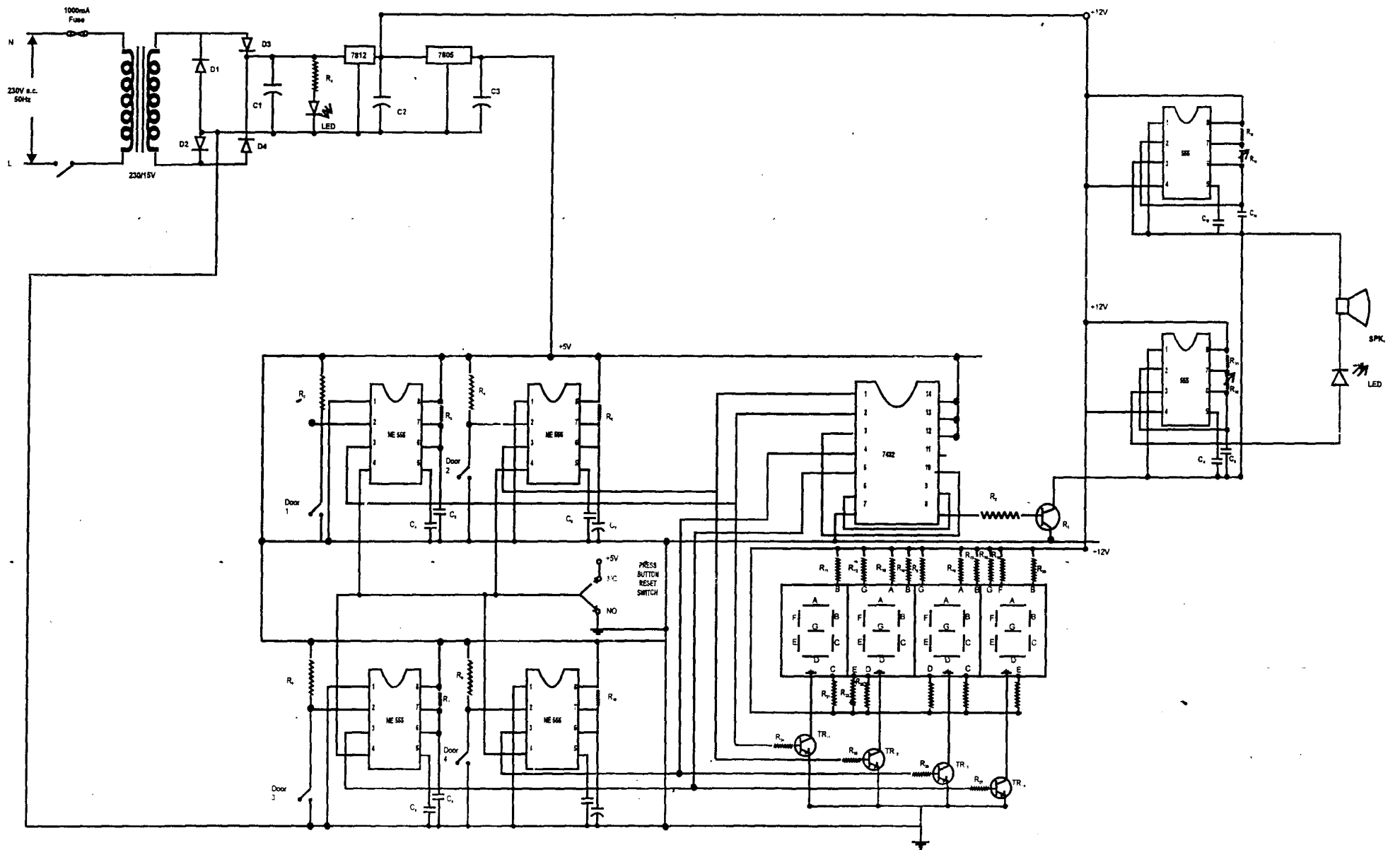

FIG 3.8 CIRCUIT DIAGRAM OF THE ENTIRE SYSTEM

## CHAPTER FOUR

### TEST, RESULT AND DISCUSSION OF RESULT

#### 4.1 CASING AND CASING CONSTRUCTION

Casing refers to the outer covering or something that serves as a container. For the purpose of this project, the material used for the casing was a plastic proper dimensioning of the casing was marked out to give the desired shape based on the size of the construction project work on Vero board. After fabricating the casing, finishing was done on it with cardboard paper to give aesthetic values to the work. The final casing that was obtained at the end of the construction is shown below:

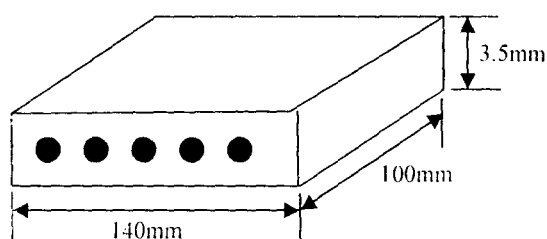

Fig. 4.1 (a) Project Main Casing

#### 4.2 TESTING AND RESULT OBTAINED

In testing the designed and constructed project work, four basic steps were taken. these steps are sequentially listed below:

**Step 1:** To ensure that all the components to be used are functionally operating, they were first tested with a digital multi meter and failed once replaced before finally soldering them on the veroboard.

**Step 2:** To ensure that there was no breakage in the circuit path on the veroboard, immediately after soldering on veroboard, the circuit path was tested using

the Digital Multi-meter. This was done to also ensure continuity of circuit on the veroboard.

**Step 3:** The period of time for the alarm sound (Time out period) was manually tested. This was achieved using Digital Stop Watch and the result obtained was found to be 51.7 seconds. The value obtained from the manual testing closely agrees with that obtained in the design specifications i.e. 1 minute.

### **4.3 DISCUSSION OF RESULT**

The sole reason of testing all the components before they were finally soldered on the veroboard is to avoid the painstaking effort it will take to disolder faulty components at the end of the day. From the continuity test carried out on the veroboard to check the circuit path. It was discovered that the circuit was in a perfect working condition as continuity was ensured.

Simulation of the circuit design was also done as mentioned earlier, with the sole objective of comparing the results obtained from design calculations to that obtained from simulation. The two results when compared closely correspond with only a very slight discrepancy in values.

### **4.4 PROBLEMS ENCOUNTERED**

It should be noted at this juncture, that the realization of the final project work was not without problems. The various problems encountered by the student include:

1. Some basic components to be used for the project work were not within reach as it was not available in town.

2. The biggest problem encountered was that of component damages in the course of soldering on the veroboard. This was due to the heat generated by the soldering iron.
3. some measuring instruments that would have provided the student with detailed analysis of the circuit (i.e. Oscilloscope, Transistor Tester) were not available.

#### **4.5 TROUBLESHOOTING GUIDE**

1. If A.C. power does not come on, first check the power plug and the rectifier circuit. If there is any one faulty, then replace component.
2. If the alarm sounds non stop continuously, then it is advisable to check the trigger unit to ensure that it is not earthed. This troubleshooting procedure will remove the problem.
3. After powering, if the device does not come on, check the LED if faulty, then replace the component and check the power supply later.
4. If the alarm does not sound at all when triggered, their check the trigger circuit first, then the reset button and finally the speaker. If the troubleshooting steps are closely followed, the device will continue to remain operational as desired.

## CHAPTER FIVE

### CONCLUSION AND RECOMMENDATION

#### 5.1 CONCLUSION

It can be concluded that the sole aim of carrying out the design and construction of *Four – door Monitoring Alarm System* was achieved, in that the aim was to develop a cheap, affordable, reliable and efficient security system, which was successfully realized at the end of the project work. One factor that accounts for the cheapness of the project was the proper choice of components used – those ones that were readily available was used, which a close substitute was found for those that were not readily available. The reliability of the entire alarm system was ensured by the integration of a seven-segment display into the circuit in conjunction with alarm system, which will be working simultaneously when alarm is ringing, the seven segment will also be displayed. The efficiency of the entire system was ensured by the use of transistor in the common collector mode to couple the output of the circuit to the speaker. The system was tested and found to be working to specifications and predictions.

Summarily, a cheap and reliable way of checking the activities of burglars and intruders has been successfully developed, which is the aim of the project. We can conclusively say therefore, that the benefits of having this monitoring alarm system can not be overemphasized.

#### 5.2 RECOMMENDATIONS

It is recommended that as a way of improving the system, the security system can be interfaced with the microcomputer to boost the effectiveness of the entire system or integrating a digital door lock.

It could be used for oil pipeline protection and car alarm with proper increase in the sensitivity of the capacitive sensor.

The Four-door Monitoring Alarm System should be effectively utilized in residential, commercial and official buildings towards of intruders and burglars.

## REFERENCES

- [1] "False Alarm", <http://www.alarmorg/false/tiops/dealertip/html>
- [2] Thomas Petruzzelis, "The alarm, sensor and security circuit book", TAB Books. Imprint of McGraw-Hill San Francisco, U. S. A. Reprinted 1974, Page 5-8.
- [3] "History of Security Alarms", [http://www.iccc.org/organisation/history\\_centre/firealarm.html](http://www.iccc.org/organisation/history_centre/firealarm.html)
- [4] C. J. Shepherd, A. H. Morten and L. F. Spence, "Basic Electrical Engineering," Pitman Publishing, Reprinted 1973, pg. 274 – 2801.
- [5] British Security Industry Association (BISA), "Journal on Security System Section Strategy for intruder alarm system? April 2005, page 1 – 4.
- [6] Rana Sampson, "Burglar Alarm," H. S. Dept. of justice, Pages 2 – 6, 13 – 15.
- [7] Ronald A. Reis, Digital Electronics, London, 1987, pg. 250 – 260.
- [8] Walker, Philip (1985), Electronic security systems, Cambridge, U. K. University Press.
- [9] Crime and violence prevention centre, California, "Home Security handbook", Page 9 -- 14.
- [10] Weber, Thad L. (1985). Alarm systems and Theft Protection (2nd Edition), Stoncham, MA: Buterworth.
- [11] [http://www.articledir.org/articles/69038/1/Alarm-systems/page 1. html](http://www.articledir.org/articles/69038/1/Alarm-systems/page%201.html). By Rick marting; Published on 01/6/2007.
- [12] Nick A. Tim, "Technical Leaflet on introduction to fire detection and Alarm", <http://www.neddc.org/alarm.html>



## APPENDIX

### LIST OF COMPONENTS USED

S/NO	DESCRIPTION	QUANTITY
1.	$D_1 = D_2 = D_3 = D_4 = \text{IN4007}$	4
2.	$C_1 = 2200\mu\text{F}/25\text{V}$	1
3.	$R_1 = 470\Omega$	1
4.	$C_2 = 1000\mu\text{F}/16\text{V}$	1
5.	$C_3 = 470\mu\text{F}/16\text{V}$	1
6.	$R_2 = R_4 = R_6 = R_9 = 10\text{K}\Omega$	4
7.	$R_3 = R_5 = R_7 = R_{10} = 1\text{M}\Omega$	4
8.	$C_4 = C_6 = C_8 = C_{10} = 0.01\mu\text{F}$	4
9.	$C_5 = C_7 = C_9 = C_{11} = 47\mu\text{F}$	4
10.	$R_{11} \dots R_{28} = 220\Omega$	18
11.	$R_{29} = 6.8\text{K}\Omega$	1
12.	$R_{30} = 50\text{K}\Omega$	1
13.	$R_{31} = R_{32} = 68\text{K}\Omega$	2
14.	$C_{12} = C_{13} = C_{14} = 0.01\mu\text{F}$	3
15.	$C_{15} = 22\mu\text{F}/16\text{V}$	1
16.	$\text{TR}_1 \dots \text{TR}_5 = 2\text{N3904}$	5
17.	Voltage regulators (LM 7812 and LM 7805)	2
18.	230/15V Transformer	1
19.	Soldering lead	2 yards
20.	Vero board	2