

DESIGN AND CONSTRUCTION OF A DC/AC INVERTER FOR A SOLAR INVERTER

BY

**ENEZE OSAREIME MAKOJU
2003/17531EE**

**DEPARTMENT OF ELECTRICAL/COMPUTER
ENGINEERING**

**SCHOOL OF ENGINEERING AND ENGINEERING
TECHNOLOGY**

October 2006

DESIGN AND CONSTRUCTION OF A DC/AC INVERTER FOR A SOLAR INVERTER

BY

**ENEZE OSAREIME MAKOJU
2003/17531EE**

**A PROJECT SUBMITTED TO THE DEPARTMENT
OF ELECTRICAL/COMPUTER ENGINEERING IN
PARTIAL FULFILLMENT OF THE REQUIREMENTS
FOR THE AWARD OF THE BACHELOR OF
ENGINEERING (B.ENG) DEGREE IN
ELECTRICAL/COMPUTER ENGINEERING,
SCHOOL OF ENGINEERING AND ENGINEERING
TECHNOLOGY.**

**FEDERAL UNIVERSITY OF TECHNOLOGY MINNA,
NIGER STATE**

October 2006

DEDICATION

**To the blessed memory of my aunty Diana
Kachikwu and also to my daughter Adesuwa
Salami.**

DECLARATION

I, Eneze Osareime Makoju, declare that this project work was done by me and has never been presented elsewhere for the award of a degree to the best of my knowledge. I also hereby relinquish the copyright to the Federal University of Technology, Minna.

ENEZE OSAREIME MAKOJU

(Name of student)

Dr. Jacob Tsado

(Supervisor)

EDMakoju 17-10-2006

(Signature and Date)

(Signature and Date)

Engr. M.D. Abdullahi

(Head of Department)

(External Examiner)

(Signature and Date)

(Signature and Date)

ACKNOWLEDGEMENTS

I would like to start off by thanking God, for seeing me through my whole University degree, which has culminated in this project.

I would also like to thank both my parents Engr. and Dr. (Mrs.) Makoju for standing by me and being there for me through thick and thin. I would also like to thank my daughter Adesuwa for being patient with her mum, as well as my siblings Enesi, Ovayoza, Onyeché, Makozi and Onimisi. My cousins Omuwa, Odegua, Izegbua and Ozohu. I would also like to thank two of the best friends I could ask for Vincent and Mudia. As well as numerous other family members for all their support and help in the past few years.

I am extremely grateful to my level adviser Mr. J.N. Kolo who always took the time to listen to me and my numerous problems and was also very patient with me especially when it came to the issue of registration.

There have been other lecturers both within and outside the department that have inspired me to do the best I can, nothing more nothing less, and for this I am eternally grateful.

I would also not forget the indispensable Mr. Thak Tu Yon and the other folks at the Pyongyang informatics center, Pyongyang, Democratic Peoples Republic of Korea; and their associates especially Mr. Zheng of Dalian Great Success company in far away Peoples Republic of China for their help in delivering the Solar panel and components.

Last but not least, I would like to acknowledge my supervisor Dr. Jacob Tsado whose guidance saw me and my partner through this project.

ABSTRACT

This project involved the design and construction of a DC/AC inverter for a small capacity solar power center. The aim is a small capacity inverter circuit, which converts the DC voltage from the solar panel/battery bank to standard 220V AC. The output of the inverter was a square wave which can be used in most appliances. The modified sine wave inverter was designed using the 4069UB logic inverters and other field replaceable components. The solar energy trapped during the day was stored using a 60Ah maintenance free car battery which can supply up to 5hours uninterrupted power supply depending on the load connected to the inverter's output. The project's capacity is 250W and it was successfully constructed and used to power some home and office appliances.

TABLE OF CONTENTS

Dedication.....	ii
Declaration.....	iii
Acknowledgement.....	iv
Abstract.....	v
List of figures and plates.....	viii
CHAPTER ONE: Introduction.....	1
1.1 Objectives.....	2
1.2 Methodology.....	3
1.3 Scope/Limitations.....	5
1.4 Source of Materials.....	6
1.5 Outside Involvement.....	6
CHAPTER TWO: Literature review on electric power systems.....	7
2.1 Inverter Technologies.....	9
CHAPTER THREE: Block diagram, design theories & analysis.....	11
3.1 Power control circuit.....	11
3.2 Inverter Circuit.....	12
3.2.1 The square wave oscillator.....	12
3.2.2 The FET drive circuit.....	14

3.2.3 The power MOSFET switching circuit.....	14
3.3 Transformer rating.....	16
3.4 Solar Charge Controller.....	16
3.4.1 Float voltage comparator circuit.....	16
3.4.2 Current switching and LED drive Circuitry.....	17
3.4.3 Current routing circuitry.....	18
3.5 Circuit implementation.....	19
3.6 Final Assembly and Casing.....	21
CHAPTER FOUR: Testing.....	23
4.1 Alignment.....	23
4.2 Use.....	24
4.3 Performance Evaluation.....	25
4.4 Results.....	27
4.5 Discussion.....	28
4.6 Caution.....	29
CHAPTER FIVE: Conclusion.....	30
Problems Encountered.....	30
Recommendations.....	30
REFERENCES.....	33
APPENDIX.....	35
GLOSSARY.....	39

List of figures and Plates

1. Fig 3.0 Solar Inverter Block diagram
2. Fig 3.1 Power control circuit
3. Fig 3.2.1 Square wave oscillator circuit
4. Fig 3.2.2 FET drive circuit
5. Fig 3.2.3 Power MOSFET switching circuit
6. Fig 3.4.1 Float voltage comparator circuit
7. Fig 3.4.2 Current switching and LED drive circuit
8. Fig 3.4.3 Current routing circuit
9. Fig 4.2 Solar inverter connection
10. Plate 4.3.1 Performance evaluation of 100W solar PV cell
11. Plate 4.4.1 Temperature performance of solar inverter
12. Plate 4.4.2 The output signal waveform
13. Fig 5.3.1 Suggested dump load circuit

Chapter one

INTRODUCTION

The world in which we live in today is highly reliant on electricity. There are various forms of electricity in use today, namely, Hydro-electricity, Gas, Wind, Coal and Solar. In Nigeria the two main forms of electricity in use are Hydro-electricity and Gas electricity. [7]

The problem with these two forms of electricity is that Hydro-electricity is highly reliant on water levels,[4, 7, 19] that is the amount of rainfall that falls in a certain area at a certain time. Nigeria is characterised to have 2 major seasons, wet and dry. Therefore, during the dry season when water levels are low you find we get an interrupted power supply. Also with global warming, deserts are fast encroaching our borders and with deserts come droughts.

Gas electricity relies on pipelines to carry the gas from the source to the power stations. In Nigeria you find that in certain areas people have a habit of vandalising these pipelines, thus interrupting the flow of gas, which in turn interrupts the supply of electricity. It can take up to 3 months to fix a leak and the use of gas is also very dangerous as it is highly inflammable.

The use of solar energy as a form of generating electricity is a fairly new concept, but at the same times a growing one. In Nigeria the use of solar energy is normally done on a personal level, for example private housing.

Solar energy is reliable and cost effective. The main problem with solar energy is the initial capital needed to set up. In the long run though, considering savings made on not buying diesel to power up generators, solar energy has been proven times without number to be the most “economical” form of energy. [5, 12, 15]

This project work was borne out of the desire to diversify our sources of electrical power and thereby cater for our ever-growing need of electrical energy especially as a developing nation. Aside the urban cities, villages and satellite towns also stand to benefit a lot from the solar power supply system due-to its portability, efficiency, environmental friendliness and ease of maintenance.

1.1 OBJECTIVES

Specifically, the aim of this project work is to build a medium capacity solar system to effectively harness the excessive solar energy, which hit us especially in sub-Saharan Africa for more than 10 hours each day. The design goals of the circuits were efficiency, simplicity, reliability, and the use of field replaceable parts.

Why solar energy?

Solar energy is viewed as the clean and renewable source of energy for the future. People can make indirect use of solar energy that has been naturally collected. Earth's atmosphere, oceans, and plant life, for example, collect solar energy that people later extract to power technology. [2, 4]

Solar energy can be derived directly as in the following examples:

- Sunlight hits the dark absorber surface of a solar thermal collector and the surface warms. A fluid circuit carries the heat energy away.
- Sunlight strikes a solar sail on a spacecraft and is converted directly into a force on the sail, which causes motion of the craft.

- Sunlight strikes a light mill and causes the vanes to rotate, although little practical application has yet been found for this effect.
 - Sunlight is focused on an externally mounted fibre optic cable, which conducts sunlight into building interiors to supplement lighting.
 - Sunlight hits a photovoltaic cell (also called a photoelectric cell) creating electricity.
- [1, 2, 4, 6]

1.2 METHODOLOGY

Most solar energy used today is harnessed as heat or electricity. Technologies that enable the use of solar energy may be grouped as below:

- Solar design is the use of architectural features to replace the use of grid electricity and fossil fuels with the use of solar energy and decrease the energy needed in a home or building with insulation and efficient lighting and appliances.
- Solar heating systems are generally composed of solar thermal collectors, a fluid system to move the heat from the collector to its point of usage, and a reservoir to stock the heat for subsequent use.
- Solar cells, also referred to as photovoltaic cells, are devices or banks of devices that use the photovoltaic effect of semiconductors to generate electricity directly from sunlight. [2, 3, 4, 6, 8]

For the purpose of this project, we shall limit ourselves to technologies that harness solar energy by photovoltaic effect using a solar cell.

Solar energy travels to Earth through space in discrete packets of energy called photons. [1, 2, 3, 4] On the side of Earth facing the Sun, a square kilometre at the outer edge of our atmosphere receives 1,400 Megawatts of solar power every minute, which is about the

capacity of the largest electric-generating plant in Nevada, USA. Only half of that amount, however, reaches Earth's surface. The atmosphere and clouds absorb or scatter the other half of the incoming sunlight. The amount of light that reaches any particular point on the ground depends on the time of day, the day of the year, the amount of cloud cover, and the latitude at that point. The solar intensity varies with the time of day, peaking at solar noon and declining to a minimum at sunset. The total radiation power (1.4 kilowatts per square meter, called the solar constant) varies only slightly, about 0.2 percent every 30 years. Any substantial change would alter or end life on Earth. [2, 5, 6, 8]

When ionised solar radiation is incident on a semi-conductor diode, energy conversion can take place with a voltage of 0.5 to 1 volt DC and a current density of 20-40mA/cm², depending on the materials used and the conditions of sunlight. Area of these solar cells decides the current output. An array of large number of such diodes (i.e. solar cells) results into higher D.C. output voltage. [10, 11, 13, 14]

Since the final form of electrical energy required is generally an alternating current, it is realised using inverters. [3, 17]

Cells with conversion efficiencies greater than 30 percent are now available. By connecting large numbers of these cells into modules, the cost of photovoltaic electricity has been reduced to 20 to 30 cents per kilowatt-hour. Americans currently pay 6 to 7 cents per kilowatt-hour for conventionally generated electricity. [5, 8, 14]

1.3 SCOPE AND LIMITATION OF WORK

This project involved the design and construction of a solar inverter. Its specification includes a solar charge controller for charging a battery bank from a solar Photovoltaic cell, a

low voltage disconnect circuit which cuts off the load when there's no sunlight and the battery power has gone down; and an inverter circuit, which converts the DC voltage from the solar panel/battery bank to standard 220V AC which can be used to power most home and office appliances.

For the purpose of this project, a small capacity system was considered, but due-to the economies of scale and the relative scarcity of lower capacity PV panel and components, a medium capacity system was designed and constructed.

1.3.1 Inverter

The inverter uses power MOSFET as switching device. I assume that this unit is used with the battery of car. So, the input voltage is +12V DC. The output voltage is AC 220V. The output voltage depends on the transformer used. The waveform of the output is square wave. Since it is a medium capacity system, it is usable with a lot of home electronics equipment. The transformer used decides the electric power, which the inverter handles. This time, we are using the transformer with 12V-20A (secondary side). So, it is possible to handle about 250W.

1.3.2 Solar Charge Controller

The solar charge controller's function is to regulate the power flowing from a photovoltaic panel into a rechargeable battery. It features easy set-up with one potentiometer for the float voltage adjustment, an equalize function for periodic overcharging, and

automatic temperature compensation for better battery charging over a wide range of temperatures.

A medium power solar system can be built with the solar charge controller, a 12V solar panel that is rated from 100 milliamps to 20 amps, and a lead acid or other rechargeable battery that is rated from 500 milliamp hours to 400 amp hours of capacity.

1.4 SOURCE OF COMPONENTS

Almost all of the components used for this project work were sourced locally. A few exception such as the 2N3905(general purpose npn transistor), the 2SJ471(P-channel MOSFET) and the 2.0K/25°C NTC Thermistor was not readily available in the Nigerian market and was delivered together with the Solar PV panel which was ordered from the People's Republic of China. For a detailed list of components and price lists, see appendix 1.

1.5 OUTSIDE INVOLVEMENT

At this point I would like to mention the involvement of the folks at the Pyongyang Informatics Institute, Pyongyang, Peoples Republic of Korea; who not only helped us in the simulation of the circuits, but also actually assisted in ordering and delivering the solar panel and components.

Chapter two

LITERATURE REVIEW

Humans have known about the existence of static electricity for thousands of years, but scientists did not make great progress in understanding electricity until the 1700s. The ancient Greeks observed that amber, when rubbed, attracted small, light objects. About 600 BC Greek philosopher Thales of Miletus held that amber had a soul, since it could make other objects move. In a treatise written about three centuries later, another Greek philosopher, Theophrastus, stated that other substances also have this power. [2, 19]

For almost 2,000 years after Theophrastus, little progress was made in the study of electricity. In 1600 English physician William Gilbert published a book in which he noted that many substances besides amber could be charged by rubbing. He gave these substances the Latin name *electric*, which is derived from the Greek word *elektron* (which means “amber”). English writer and physician Sir Thomas Browne first used the word electricity in 1646. [10, 19]

17th-century German physicist Otto von Guericke, who observed conduction in a linen thread, discovered the fact that electricity can flow through a substance. Von Guericke also described the first machine for producing an electric charge in 1672. The machine consisted of a sulfur sphere turned by a crank. When a hand was held against the sphere, a charge was induced on the sphere. Englishman Stephen Gray rediscovered conduction independently during the early 1700s. Gray also noted that some substances are good conductors while others are insulators. [11, 19]

Also during the early 1700s, Frenchman Charles Dufay observed that electric charges are of two kinds. He found that opposite kinds attract each other while similar kinds repel. Dufay called one kind vitreous and the other kind resinous. [2, 4, 19]

In 1791 Italian biologist Luigi Galvani published the results of experiments that he had performed on the muscles of dead frogs. Galvani had found earlier that the muscles in a frog's leg would contract if he applied an electric current to them.

In 1800 another Italian scientist, Alessandro Volta, announced that he had created the voltaic pile, a form of electric battery. The voltaic pile made the study of electric current much easier by providing a reliable, steady source of current. Danish physicist Hans Christian Oersted demonstrated that electric currents are surrounded by magnetic fields in 1819. Shortly afterward, André Marie Ampère discovered the relationship known as Ampere's law, which gives the direction of the magnetic field. Ampère also demonstrated the magnetic properties of solenoids. Georg Simon Ohm, a German high school teacher, investigated the conducting abilities of various metals. In 1827 Ohm published his results, including the relationship now known as Ohm's law. [19]

In 1830 American physicist Joseph Henry discovered that a moving magnetic field induces an electric current. The same effect was discovered a year later by English scientist Michael Faraday. Faraday introduced the concept of lines of force, a concept that proved extremely useful in the study of electricity.

About 1840 British physicist James Prescott Joule and German scientist Herman Ludwig Ferdinand von Helmholtz demonstrated that electricity is a form of energy and that electric circuits obey the law of the conservation of energy. [2, 10, 11, 19]

2.1 INVERTER TECHNOLOGIES

As early as 1922, Tripplite, a Chicago based company started producing inverters which used mechanical vibrators to oscillate DC power into square wave AC. After the Second World War, Redi-line which are still available today, consisted of an AC generator whose armature was driven by a DC motor. The motor generator was quite reliable with its output waveform compatible with a wide variety of applications, but it was inefficient, it required 30Amps to turn on and it had no surge capacity[7, 16]

In the early 1960s, after the invention of the transistor by William Shockley in 1948, solid state transistors replaced the mechanical vibrators. Man's exploration of space dictated a need for instrumentation having fast response, low power consumption, low component densities and low thermal dissipation. On the 9th of June 1966, NASA awarded patent for the inverter circuit to inventor John C. Sturman for his transistorized logic inverter design. Accordingly, an object of the logic inverter circuit invention is to provide low-impedance drive in both the positive and negative directions. Another object of the instant invention is to provide for a logic inverter circuit having increased efficiency and decreased power consumption. Still another object of the invention is to provide for a logic inverter circuit having faster rise and fall times than heretofore obtained with other circuits operating with comparable power.[12]

Varner Inc. introduced their first inverter, a modified sine wave unit. For this 1000Watt inverter, Vanner patented true root mean square (RMS) regulation and a power transistor drive technique with very high efficiency. In 1986, one of the inverters included a microprocessor control circuit.

First generation inverters used Meteriod Darlington Technology, this special circuit metered base current to power a load. Second generation inverters used FETs which have almost no switching losses and improved efficiency.

Starpower Technologies Corporation with headquarters in British Columbia, Canada was founded in 1988, manufactured modified sine wave inverters using high frequency design, and provided portable power for remote areas worldwide. In 1995, they introduced a pure sine wave inverter/charger using high frequency switching techniques; they successfully produced a high output charger with a power factor approaching unity. There is negligible distortion at the DC part in both inverter and charger, which is viewed as a technological milestone. [7, 16]

Heart Interface Inc., Trace Engineering and other companies and individuals have been designing and building inverters whose output is a multi-step approximation that results in fewer load incompatibilities. Most inverters accomplish the inversion process by performing two main functions: first they convert DC into AC, and then step-up the resulting AC into mains voltage level using transformers. [5, 12, 16]

Chapter three

DESIGN THEORIES

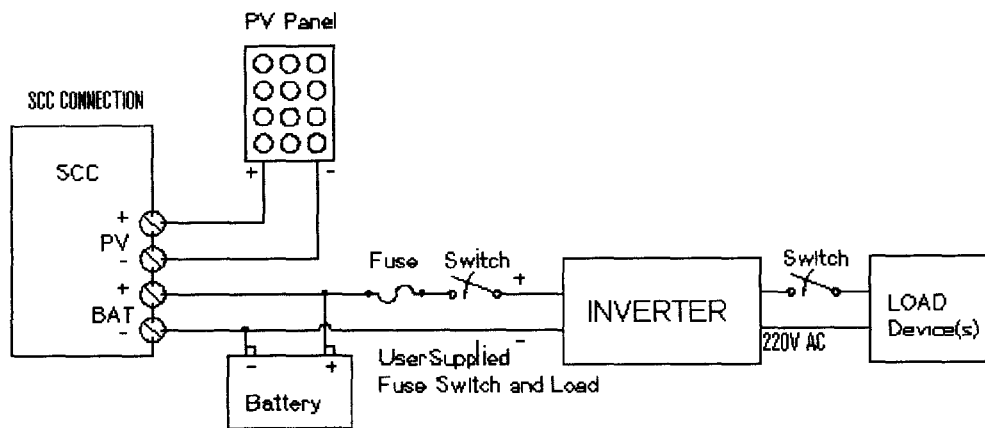

Fig 3.0 Block diagram for Solar Inverter

3.1 POWER CONTROL CIRCUIT

The power control circuit of fig 3.1 routes the operating current from the solar panel input through Q1 and U2. When the solar panel voltage exceeds 12V, zener diode D2 conducts and turns on Q1, providing power to U2. U2 produces a regulated 5 Volt power source. The 5V is used to power the circuit's logic and as a reference voltage for comparing to the battery float voltage.

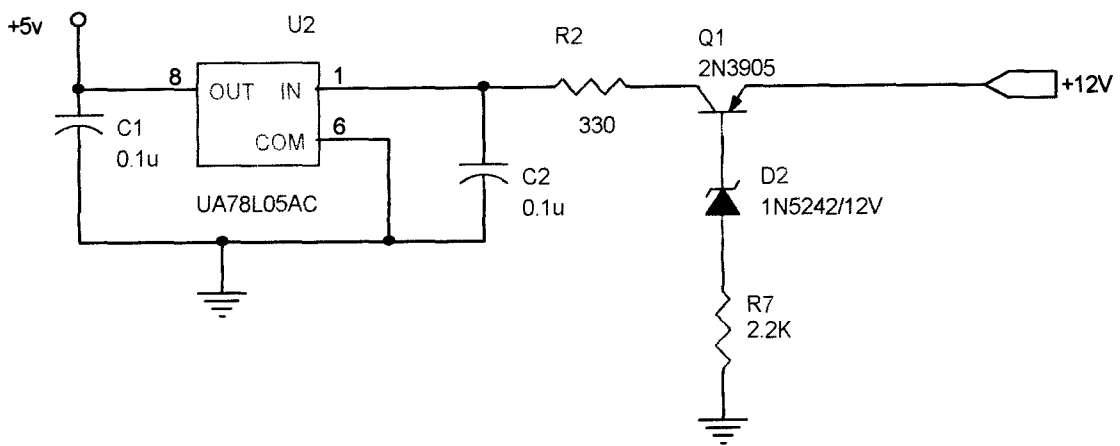

Fig 3.1 Power control circuit

3.2 INVERTER CIRCUIT

The inverter circuit consists of a square wave oscillator, the field effect drive circuit, the Power MOSFET switching circuit.

3.2.1 The square wave oscillator

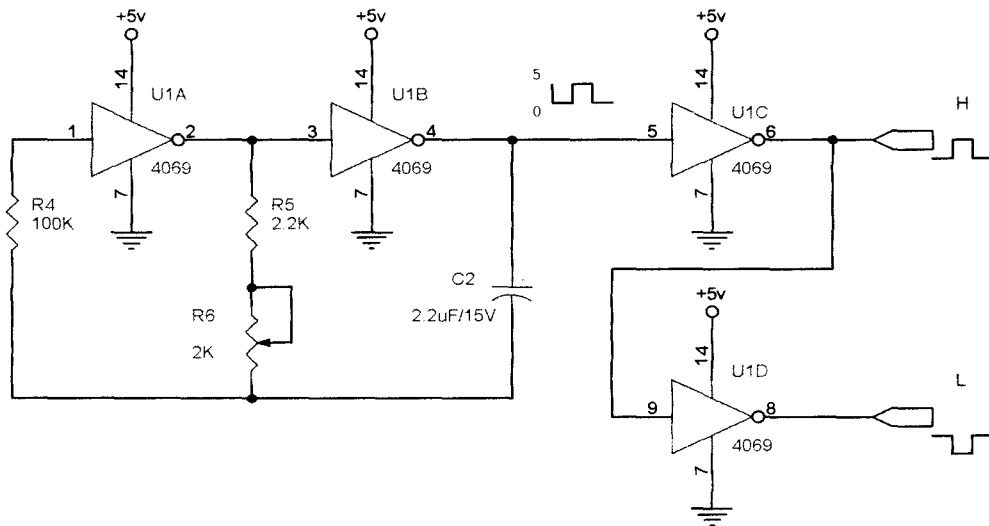

Fig 3.2.1 square wave oscillator circuit

The Square wave oscillator of fig 3.2.1 uses CMOS-type logic inverters. I use the word "logic inverter" to avoid confusion with the solar DC/AC inverter. The output of the oscillator is connected with the drive circuit through the logic inverters. The antiphase signal of the alternating current is created using the logic inverter, too. The input of the logic inverters was connected in such a way that it would not be used with the grounding to avoid bad influence.

It is possible to set the frequency of oscillation to 50 or 60 Hz with the variable resistor R6 but because of the possibility of an error in the actual circuit, we used it as a reference. The resistor and capacitor values were chosen to set the oscillation frequency as shown below.

Minimum frequency

$$\begin{aligned}f_{\min} &= 1/[2.2 \times C_2 \times (R_5 + R_6)] \\&= 1/(2.2 \times 2.2 \times 10^{-6} \times 4.2 \times 10^3) \\&= 1/(20.328 \times 10^{-3}) \\&= 49.2 \text{ Hz}\end{aligned}$$

Maximum frequency

$$\begin{aligned}f_{\max} &= 1/(2.2 \times C_2 \times R_5) \\&= 1/(2.2 \times 2.2 \times 10^{-6} \times 2.2 \times 10^3) \\&= 1/(10.648 \times 10^{-3}) \\&= 93.9 \text{ Hz}\end{aligned}$$

3.2.2 The FET drive circuit

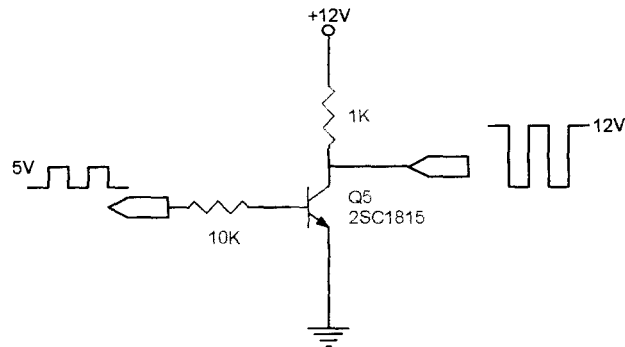

Fig 3.2.2 Field effect drive circuit

Because the output of the oscillator is the TTL of 0V to 5V, it is converted into the amplitude of vibration of 0V to 12V to drive an FET with npn bipolar junction transistor, Q5 as shown in fig 3.2.2.

3.2.3 The power MOSFET switching circuit.

The switching circuit of fig 3.2.3 is the main circuit of the DC/AC inverter. Two sets of C-MOSFET circuits were used and are controlled by the antiphase signals.

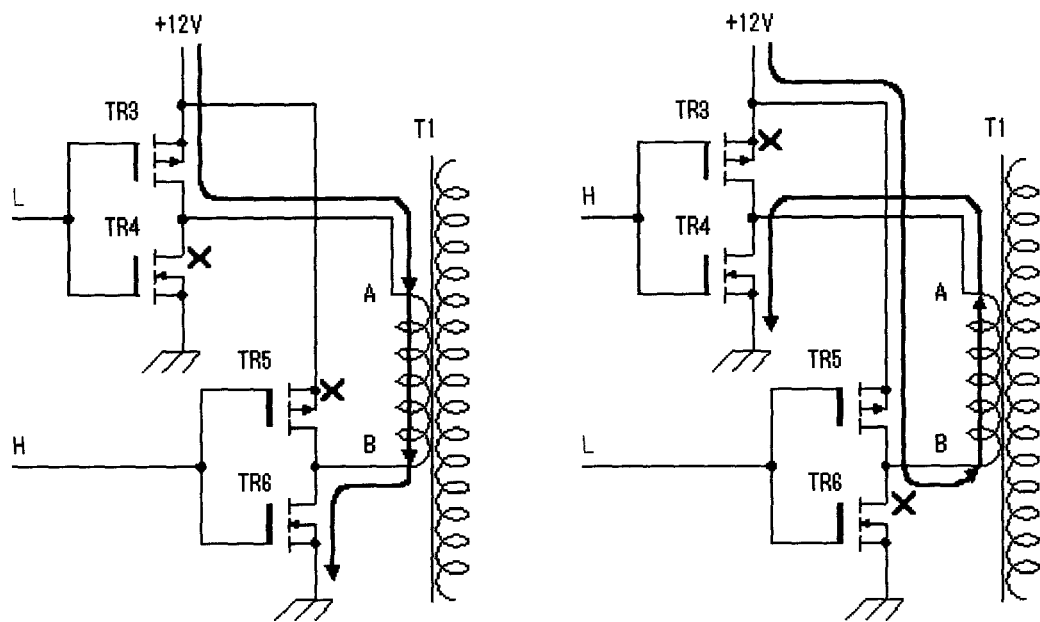

Fig 3.2.3 Power MOSFET switching circuit

When the inputs of TR3 and TR4 are L level and the inputs of TR5 and TR6 are H level, TR3 and TR6 become ON condition and TR4 and TR5 become OFF condition. Therefore, the electric current flows through the direction of A to B to the secondary coil (12V side) of the transformer.

When the input level is opposite, TR3 and TR6 become OFF condition and TR4 and TR5 become ON condition. Therefore, the electric current which flow through the transformer becomes contrary to the first case, which is from B to A so the current flows alternating in the secondary side of the transformer. Hence 12V DC becomes 12V AC, which is stepped up by transformer action to 220VAC.

Either above-mentioned condition continues even when the oscillator stops. Therefore, a big

electric current flows on the secondary side of the transformer. The 15A fuse must be used to protect the circuit.

3.3 TRANSFORMER RATING

The basic Power formula is $P=VI$.

Between input and output of the transformer we have:

Power input = Power output

Since we want about 220W output at 220V then we need 1A at the output. Then at the input we must have at least 18.3A at 12V because:

$$12V * 18.3 = 220v * 1$$

So we used a 12V to 220V step-up transformer whose input winding must be capable to bear 20A.

3.4 SOLAR CHARGE CONTROLLER

The solar charge controller consists of a float voltage comparator, a current switching and LED drive comparator and a current routing circuit.

3.4.1 Float voltage comparator circuit

The float voltage comparator U2A compares the battery voltage (divided by R1/R3 and R5) to a reference voltage (divided by R6 and R9). The comparison point is offset by the thermistor RT1 for temperature compensation. The Equalize switch, SW1 and R4, also

modifies the comparison point. The output of U2A goes high (+5V) when the battery voltage is below the float voltage setting. The output goes low when the battery voltage is above the float voltage setting. This provides the charge/idle signal that controls the rest of the circuit as shown in fig. 3.4.1

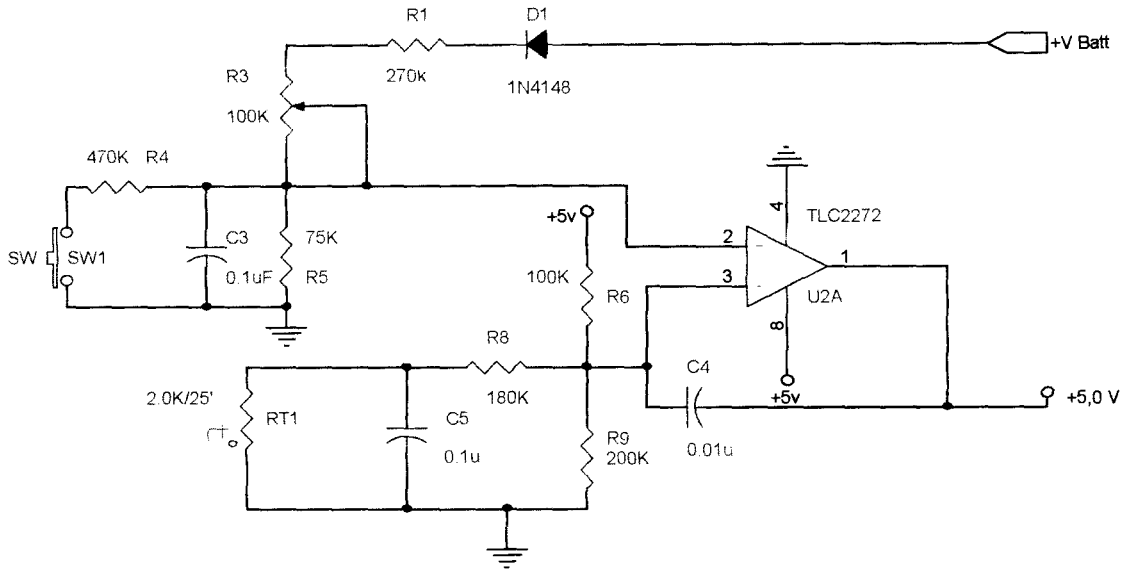

Fig 3.4.1 Float voltage comparator circuit

3.4.2 Current switching and LED drive Circuitry

The charge/idle signal is sent to U3A and U3B, a pair of D-type flip-flops. The U2B phase-shift clock oscillator clocks the flip-flops. The clocking causes the flip-flop output to produce a square wave charge/idle signal that is synchronized with the frequency of the clock oscillator. The two halves of U3 operate in synchronization as shown in fig 3.4.2. U3A is used to drive the current switching circuitry. U3B is used to drive the charging state indicator LED: - either red (charging) or green (floating).

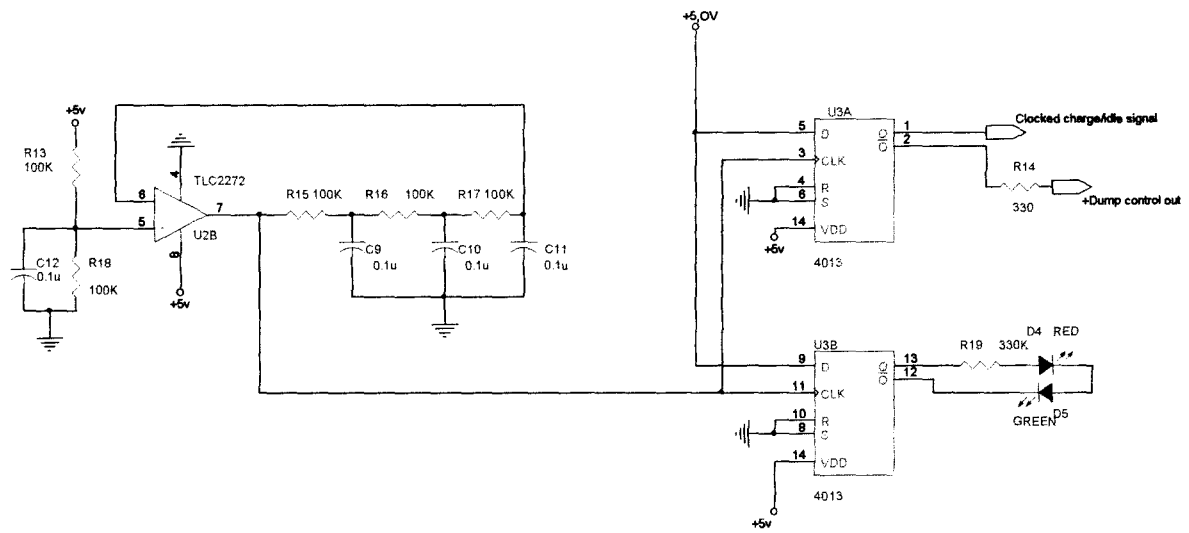

Fig 3.4.2 Current switching and FET drive circuit

3.4.3 Current routing circuitry

The clocked charge/idle signal switches bipolar transistor Q3 on and off. The Q3 signal is used to switch power MOSFET Q2, which switches the solar current on and off through the battery. The solar charging current flows through the heavy lines on the schematic. Diode D3 prevents the battery from discharging through the solar panel at night. Fuse F1 prevents excessive battery current from flowing in the event of a short circuit. Transzorb TZ1 absorbs transient voltage spikes that may be caused by lightning.

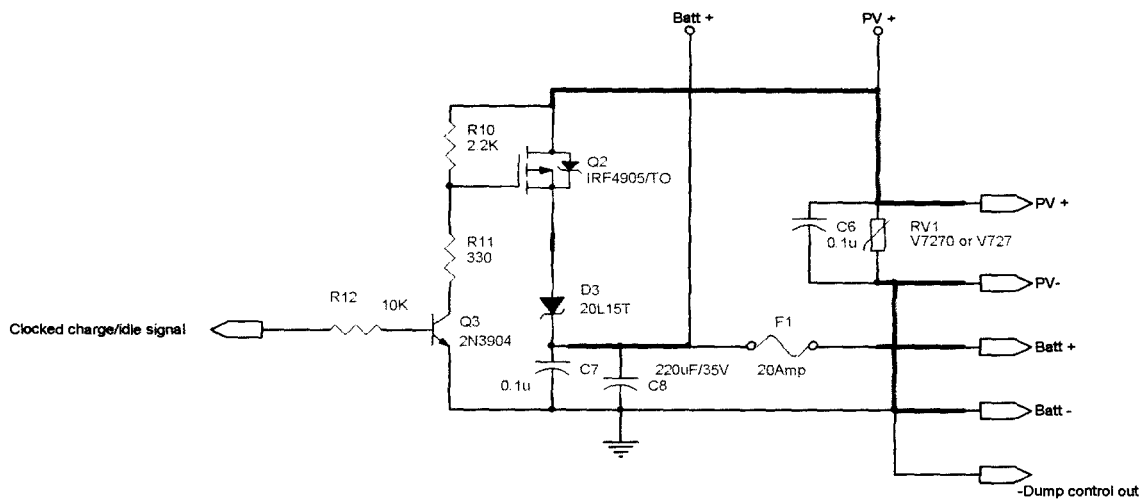

Fig 3.4.3 Current routing circuit

3.5 CIRCUIT IMPLEMENTATION

The circuit was constructed using the following basic components:-

1. Inverter IC for oscillator (4069UB):- This logic inverter is used to make about 40Hz to 70Hz square wave.
2. Power Regulator IC (78L05):- This 3-pin IC is used to make stable +5V from +12V.
3. Transistor for FET drive (2SC1815):- This is the transistor to drive the MOS FET with the square wave signal by 4069UB. The output of oscillator is converted into the 0V to 12V to control the FET with this transistor.
4. Variable resistor for the frequency adjustment: - This is the variable resistor to adjust an oscillation frequency.
5. Capacitor for oscillator: - We used the tantalum capacitor with 2.2 μ F.
6. Resistors: - We used power film type of 1/8 W.
7. Multilayer ceramic capacitor for power bypass: - This capacitor is used to pour the high frequency component of the power into the ground.

8. Printed board: - A Vero-board was used. It was cut to the desired size.
9. Transformer: - I used a transformer with the following specification.
Primary side voltage : 220-230V
Secondary side voltage : 12V (without center-tap)
Secondary side current : 20A
Size : 100mm(W), 85mm(H) and 100mm(D)
Weight : about 2.5Kg
10. Power MOS FET (2SJ471):- This is P channel MOSFET.
The maximum drain current is 30A.
When the FET is in the ON condition, the resistance between drain and source is 25 milli-ohms. So, the electric power loss when the 20A electric current flows in the ON condition is 10 W.
11. Power MOS FET (2SK2956):- This is N channel MOS FET.
The maximum drain current is 50A. When the FET is in the ON condition, the resistance between drain and source is 7 milli-ohms. So, the electric power loss when the 20A electric current flows in the ON condition is 2.8 W.
12. Power MOSFET (IRF4905/TO)
13. FETs (2N3904 & 2N3905):- C-MOSFET.
14. Heat sink: - An FET is used in the ON condition or the OFF condition. The electricity consumption of the FET is small. But I used a large heat sink for the safety.
The size is 100mm x 100mm x 17mm
15. Fuse: - A Fuse must be used to protect the circuit when the oscillator switching of the input current stops and a large electric current flows on the secondary side of

transformer. I used a pipe glass-type fuse for the easiness of the exchange. The fuse rating is 15A.

16. Op-Amp IC (TLC2272CP):- Float voltage comparator IC.
17. CMOS IC (CD4013BE):- D-type flip-flop which produce a square wave charge/idle signal that is synchronized with the frequency of the clock oscillator.
18. Thermistor (2.0K@25°C):- Negative temperature coefficient of resistance thermistor.
19. Light emitting diodes (red and green).
20. ON/OFF switch

3.6 FINAL ASSEMBLY AND CASING

We used a plastic casing for the project. We selected a case according to the size of the transformer. The size is 360mm width, 85mm height and 133mm depth.

For the DC input, due-to polarity, we used an in-to-in plug which has a structure which does not connect oppositely. We used an outlet for the home electronics equipments for the A.C output.

We used wiring materials of 15A rating for the wiring which the big electric current on the 12V side flows through.

Since the heat generated by the FETs rise up, the FETs are installed on a low position on the heat sink. We also painted silicon grease on the FETs so that the heat would spread more rapidly through the heat sink. Because both 2SJ471 and 2SK2956 are mold type, it does not need to use silicon rubber for the insulation. We also made holes by the sides of the casing to give sufficient ventilation.

The case was almost full when a transformer and the assembled board was installed, we put control unit to the front panel.

Careful work was needed so as not for the soldering iron to touch the vinyl wires because the wire was thick and the case was narrow. We used an 80-W soldering iron. The small soldering iron cannot solder a thick wire.

I connected a wire from the drain of the FET with the terminal of the transformer. Each drain could be connected at the place of the heat sink, but because the space was narrow, I extended a wire from each drain and connected them with the terminal of the transformer.

Chapter four

TESTING

The battery's negative and positive terminals were connected to the board's BAT- and BAT+ terminals respectively. The solar panel's negative and positive terminals were then connected to the board's PV- and PV+ terminals respectively.

The solar Panel was pointed towards the sun. As the sun shines on the panel, the red LED lights up. The LED was shaded from direct sunlight to be visible. The LEDs can be red, green, or alternating red and green depending on the battery voltage.

The solar panels' voltage was measured with the voltmeter. The result was recorded. The battery's voltage was also measured with the voltmeter and recorded.

The solar panel must be at a higher voltage than the battery for the SCC circuit to charge the battery.

4.1 ALIGNMENT

The equalize switch (closest to the board edge) was turned off. The potentiometer, R3 was turned 25 times clockwise so that the red LED is ON.

R3 was then turned counter clockwise until the LEDs starts blinking red and Green. This is the float voltage setting of the battery.

While measuring the battery voltage, the R3 was adjusted clockwise to align the float voltage set point. Since the LED turns red before the battery voltage reaches the desired float voltage, we left the battery to charge for a while.

When the battery is fully charged, its voltage equaled the float voltage and the LEDs blinked red and green alternatively. According to battery manufacturer's recommendations for the optimal float voltage setting, the float voltage should be set when the board and battery are at room temperature. Typical 12V set points are 13.8V for a gel cell and 14.5V for a wet cell. The float voltage was adjusted again, after the battery was fully charged and the LED is green with occasional red flashes.

4.2 USE

Connect the solar panel to the solar charge controllers PV terminals; connect the battery to the solar charge controller's battery terminals.

Put the solar panel in the sun, and watch the battery charge up.

When the battery is low and the sun is shining, the red LED lights up. As the battery reaches the float voltage, the Light emitting diodes will alternate red/green. When the sun goes down, the LEDs will shut off.

The output of the battery is the input to the inverter circuit as shown below

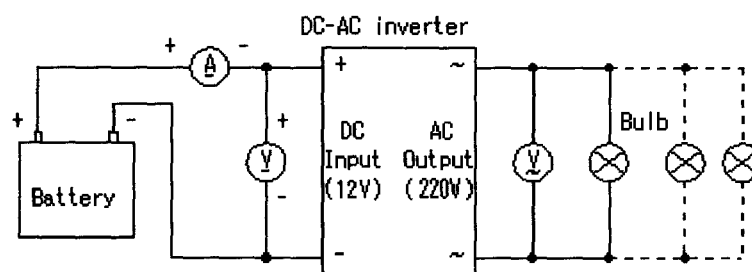

Fig 4.2 Solar Inverter use

4.3 PERFORMANCE EVALUATION OF INVERTER

While varying the load by changing the wattage of the bulb, we measured the input voltage, the input electric current and the output voltage.

The output voltage falls when a big load is connected. The electric power consumed by the bulb varies with the output voltage. So, converting to the consumption electric power according to the change of the voltage. In this case, I assume that the resistance value of the bulb doesn't change. However, the resistance value of the bulb changes with the consumption electric power. So, the result has errors by this conversion. Also, the voltage and the current are not sine wave. The result has more errors. However, these errors didn't have a big influence on the result.

For the 60-W bulb

The resistance value of the bulb is given by:

$$R = V^2/P = (220)^2/60 = 807 \Omega$$

(I assume that this value doesn't change with the voltage.)

The consumption electric power when the voltage is 215V is given by:

$$P = V^2/R = (215)^2/807 = 57.5 \text{ W}$$

When the output power is about 220W, the 10A electric current flows through the input. This is the maximum rating of this inverter. In this case, the output voltage is falling to about 200V. When connecting any more loads, the output voltage falls more. So, in case of practical use, the output of 250W is a limit for this inverter. A heavy current flows in the

secondary of the transformer when the battery is completely discharged and the inverter circuit stops. The 15A fuse should be used to protect the inverter circuit from this current.

We used a thermocouple thermometer to measure the temperature rise of the FET when the inverter is used in the continuous duty with the maximum load. The measurement place is the heat sink, where the FETs are placed.

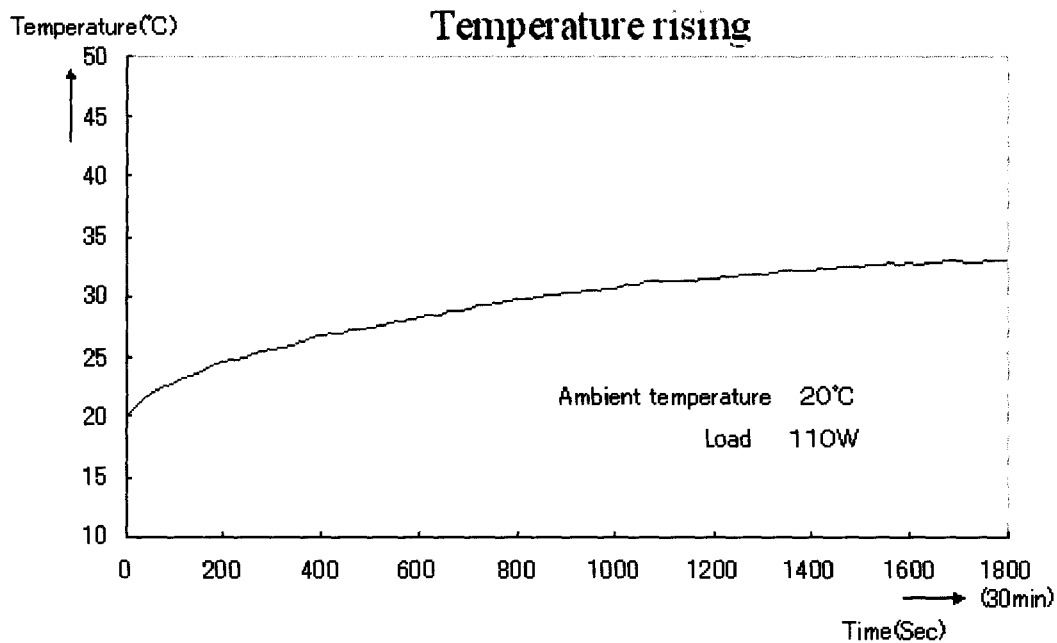

Plate 4.4.1 Temperature performance of solar inverter

The output of the inverter was observed using a two-channel oscilloscope. The output signal is a square wave. When the load becomes big, the wave form of the output voltage will be slightly changed by the nature of a coil of the transformer.

There is a slight change in the wave form of the rising edge and the falling edge. However, it is permitted to say that it is hardly changing.

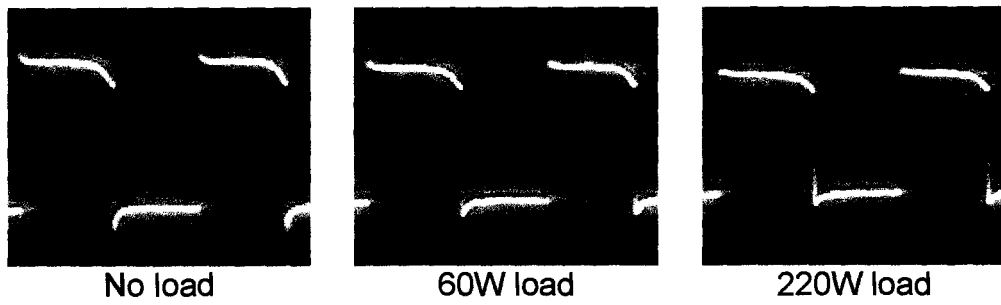

Plate 4.4.2 The output signal waveform

4.4 RESULTS

The performance evaluation of the solar panel can be summarised using the graph below:-

100W 组件 I-V 曲线图

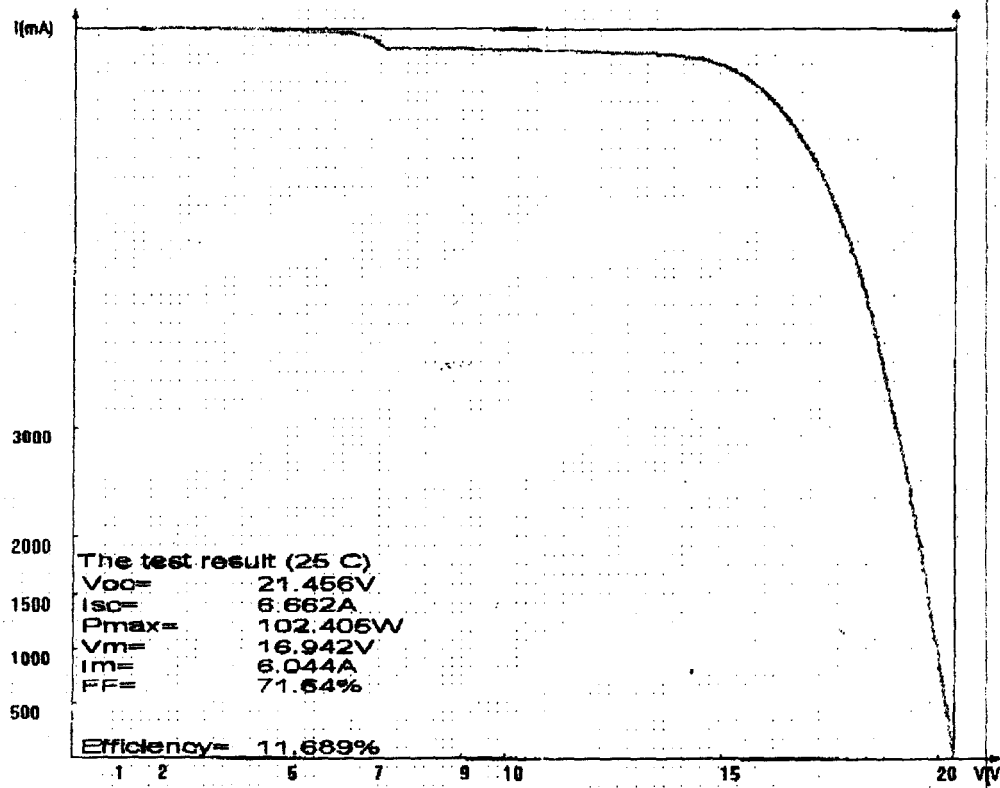

Plate 4.3.1 Performance evaluation of the 100W Solar Panel.

After a series of tests, the following average results were obtained as shown in table 4.3.1 below. The battery floats at 14.5V.

Sunshine charging time (hours)	Battery voltage (volts)
1	11.0
2	11.9
3	12.6
4	13.4
5	14.0
6	14.5

Table 4.3.1 Average solar charger test results

4.5 DISCUSSION

It is advisable to match the solar panel's maximum current to the battery's amp-hour rating (C), a typical battery charging current is C/20, so a 100-amp hour battery should have a solar panel rating of around 5 amps. Consult the battery manufacturer's data sheets for the best rating.

Systems where the battery is frequently discharged way down should occasionally be run in equalize mode from several hours to a full day.

4.6 CAUTION

Reversing the battery polarity can damage capacitor C8.

Large batteries can produce dangerous currents that can cause burns and fire hazards.

Remove loose metal jewelry when working with lead acid batteries.

The internal resistance of the battery used is very low and a high electric current (over 100A) flows through if its terminals are short-circuited. So short-circuiting the battery was absolutely avoided.

Chapter five

CONCLUSIONS

After all said and done, a solar inverter was successfully designed and constructed. The inverter could power about three electrical appliances whose combined capacity is 250W. The solar charger ensures long battery life and can fully charge a drained battery within 6 hours under good sunlight conditions. The solar inverter was tested and found to be in perfect working condition.

5.1 PROBLEMS ENCOUNTERED

Apart from the initial cost capital and the difficulties in obtaining some of the project components, no other problem encountered during the cause of the project design and construction. Actually, I think the initial capital is worth it because from experience, this design has a very long life span of about 20years.

5.2 RECOMMENDATIONS

5.2.1 Dump load Circuit

When the battery reaches the float voltage, the main circuit turns off the solar power. This otherwise wasted power can be steered to a power resistor or other load device through the second IRF-4905 MOSFET transistor. Typical uses of the dump current would be to warm the battery bank in a cold climate, or to heat a small water tank. In installations where the

main battery reaches a full charge early in the day, the dump current can be used to provide power to a secondary solar charge controller/battery pair.

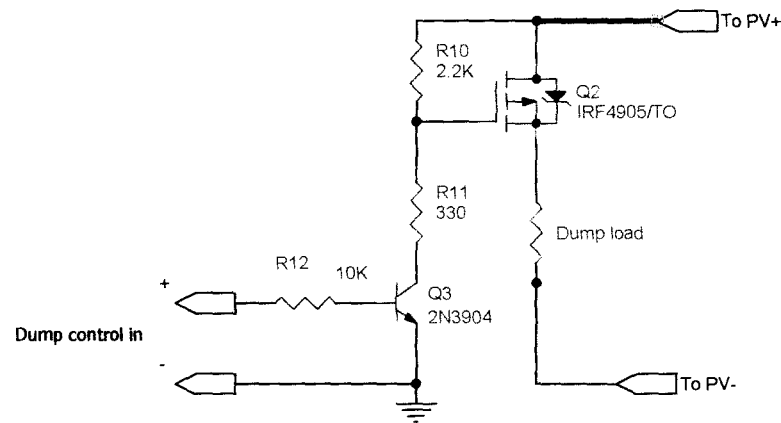

Fig 5.3.1

5.2.2 Solar energy from space

One possibility for the future is the use of excess solar-generated electric energy as a supplemental source for existing power networks. Uncertain economics and reliability, however, will make this plan difficult to implement.

A futuristic proposal to produce power on a large scale envisions placing giant solar modules in geostationary Earth orbit. Energy generated from sunlight would then be converted to microwaves and beamed to antennas on Earth for conversion to electric power. The Sun would shine on a solar collector in geostationary orbit almost 24 hours a day; moreover, such a collector would be high above the atmosphere and so would receive the full power of the Sun's rays. Consequently, such a collector would gather eight times more light than a similar collector on the ground. To produce as much power as five large nuclear power plants (1

billion watts each), several square miles of solar collectors, weighing 10 million pounds, would need to be assembled in orbit. An Earth-based antenna five miles in diameter would be required to receive the microwaves. Smaller systems could be built for remote islands, but the economies of scale suggest advantages to a single large system.[2]

13. Dunbar, P.M., and J.R. Hauser, "A study of efficiency in low resistivity silicon solar cells," *Solid state Electronics*, 19, 1976, p.95
14. Howell, P., "Generating electricity from solar energy," *Electronics and Power*, 21, 1975, p.625.
15. <http://www.dutchsolar.com/download/inverters/phillips.pdf>
16. "[http://en.wikipedia.org/wiki/Inverter_\(electrical\)](http://en.wikipedia.org/wiki/Inverter_(electrical))"
17. <http://www.solarpanelinfo.com/solar-panels/inverters/>
18. "Electricity." *Microsoft® Encarta® 2006* [DVD]. Redmond, WA: Microsoft Corporation, 2005.
19. <http://whyfiles.org/041solar/main2.html>

REFERENCES

1. Levine, Randolph H., and Lang, Kenneth R. "Sun." *Microsoft® Encarta® 2006* [DVD]. Redmond, WA: Microsoft Corporation, 2005.
2. Holladay, April. "Solar Energy." *Microsoft® Encarta® 2006* [DVD]. Redmond, WA: Microsoft Corporation, 2005.
3. A.K. Theraja & B.L. Theraja, A Textbook Of Electrical Technology(2003) S. Chand & Company Ltd. (Pp 792-800)
4. <http://www.renewable-energy-source.info/solar-energy.htm>
5. <http://www.jaycar.com.au/images/inverter>
6. <http://whyfiles.org/041solar/main3.html>
7. <http://www.national.com/history.htm>
8. A. G. Milnes, Semiconductor Devices and Intergrated Electronics(1987); Van Nostrand Reinhold Company Inc. (pp 705-753)
9. Bedford, B. D.; Hoft, R. G. et al (1964). *Principles of Inverter Circuits*. New York: John Wiley & Sons
10. Barnett, A.M., and A. Rothwarf, "Advances in the development of efficient thin film CDS/Cu₂S solar cell," Conference Record of the twelfth IEEE Photovoltaic Specialists Conference, 1976, p. 544.
11. Rothwarf, A. and K.W. Boer, "Direct conversion of solar energy through photovoltaic cells," Progress in Solid-State Chemistry, 10, 1975, p.71.
12. [http://grchistory.grc.nasa.gov/NASA Glenn Research Center History Timeline.htm](http://grchistory.grc.nasa.gov/NASA_Glenn_Research_Center_History_Timeline.htm)

Appendix one

BILL OF ENGINEERING MEASUREMENTS AND EVALUATION (BEME)

Battery Charger Circuit components

S/No	Function	Description/Specification	Quantity	Price/unit(Naira)	Total
1	Capacitor	0.1uF	10	20	200
2	Capacitor	0.01u	1	20	20
3	Capacitor	220uF/35V	1	30	30
4	Diode	1N4148	2	10	20
5	Zener Diode	1N5242/12V Zener	2	10	20
6	Zener Diode	20L15T Zener	2	10	20
7	LED	RED	2	10	20
8	LED	GREEN	2	10	20
9	Fuse	20Amp	1	10	10
10	FET	2N3905	2	10	20
11	FET	IRF4905/TO	2	30	60
12	FET	2N3904	2	30	60
13	Thermistor	2.0K/25°C NTC Thermistor	2	0	0
14	Varistor	V7270 or V727 Varistor	2	150	300
15	Resistor	270k	1	10	10
16	Resistor	330	4	10	40
17	Resistor	100K	7	10	70
18	Resistor	470K	1	10	10
19	Resistor	75K	1	10	10
20	Resistor	2.2K	2	10	20
21	Resistor	180K	1	10	10
22	Resistor	200K	1	10	10
23	Varistor	10K	1	10	10
24	On/Off Switch	SW	1	40	40
25	Power regulator IC	UA78L05AC	2	80	160
26	Op Amp IC	TLC2272CP	2	100	200
27	CMOS IC	CD 4013BE CMOS	2	80	160

Total=1550

Inverter componets

S/No	Function	Description/Specification	Quantity	Price/Unit(Naira)	Total
1	Capacitor	100uF/25V	1	30	30
2	Capacitor	2.2uF/15V	1	20	20
3	Fuse	20Amp	1	10	10
4	Transistor	2SC1815	4	10	40
5	FET	2SJ471	4	30	120
6	FET	2SK2956	4	20	80
7	Resistor	1K	2	10	20
8	Resistor	10K	2	10	20
9	Resistor	100K	1	10	10
10	Resistor	2.2K	1	10	10
11	Resistor	2K	1	10	10
12	T1	STEPUP TRANSFORMER	1	1500	1500
13	CMOS IC	CD 4069	2	150	300

Total=2170

Grand Total= N 3,720.00

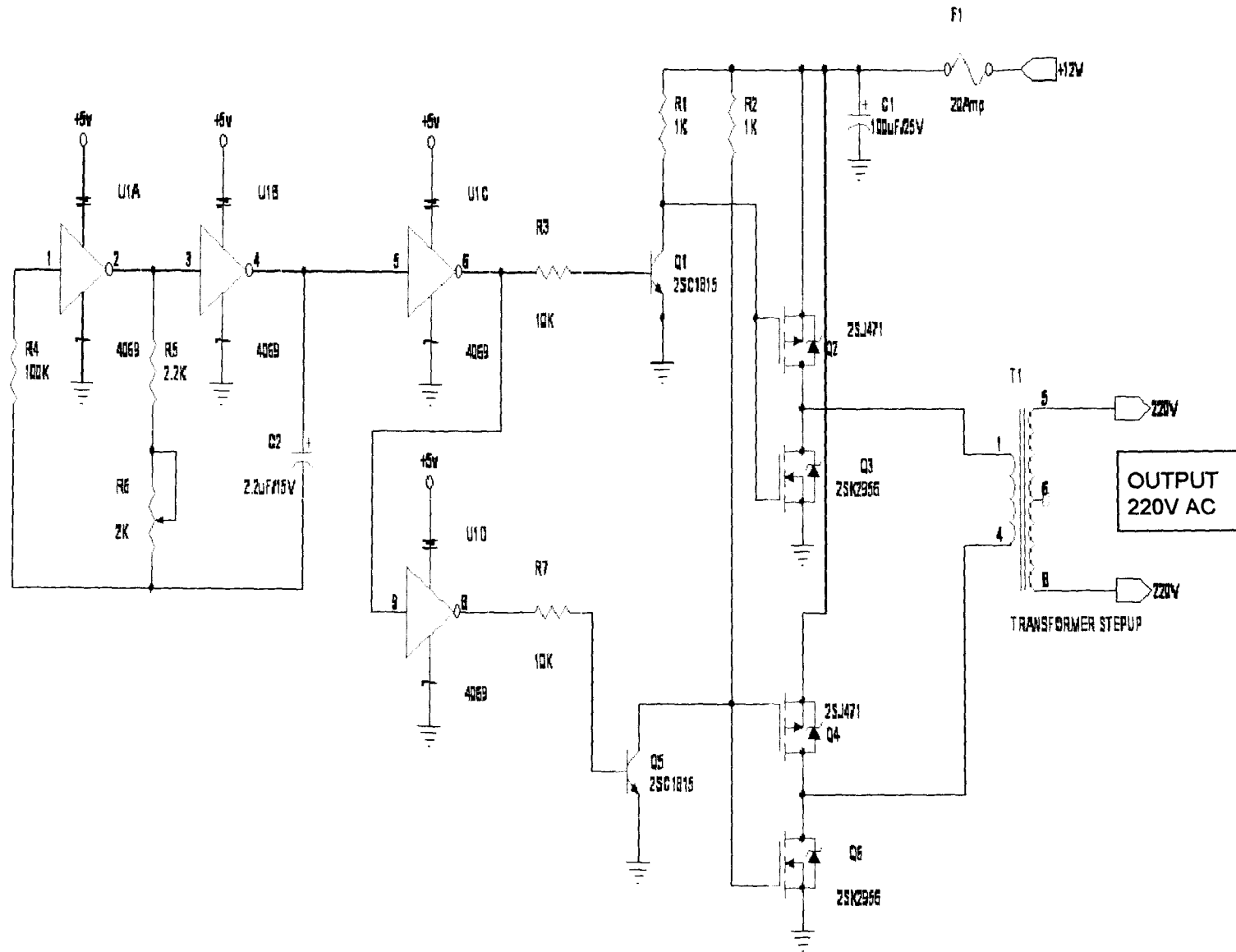

INVERTER CIRCUIT

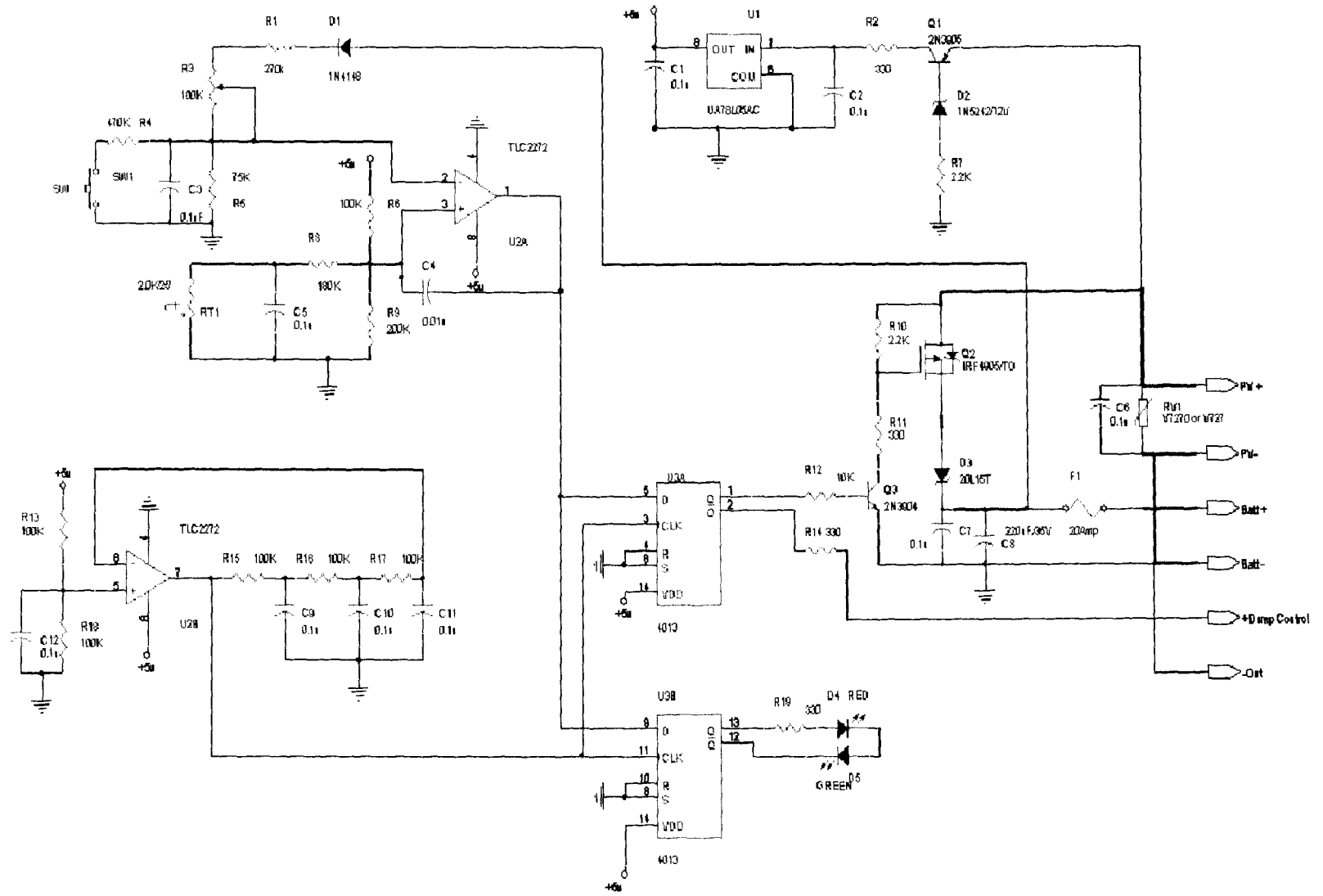

SOLAR CHARGE CONTROLLER CIRCUIT DIAGRAM

Appendix four

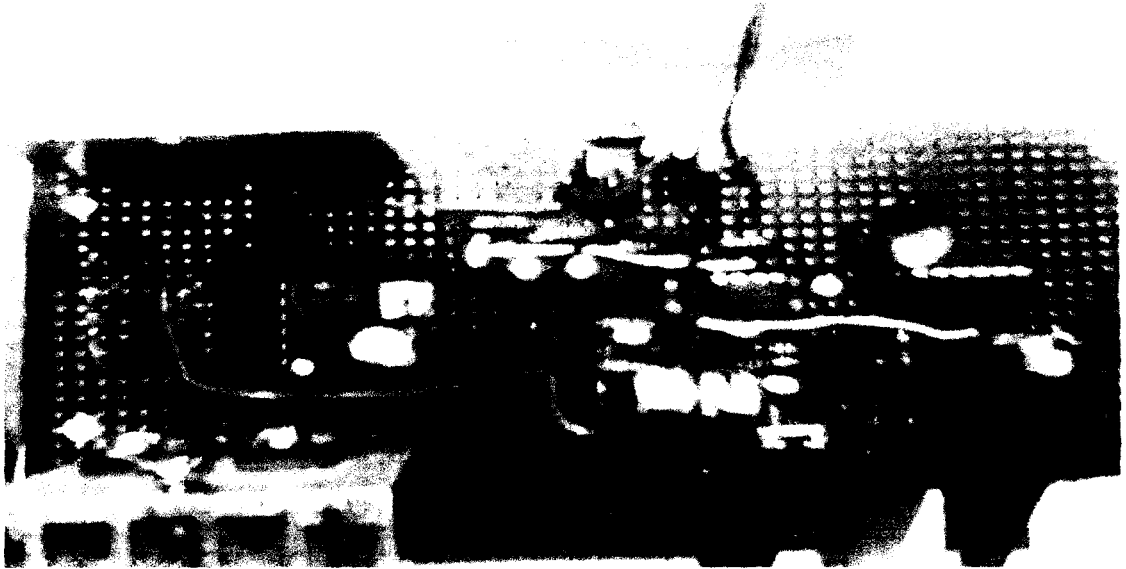

Components assembled on PCB board

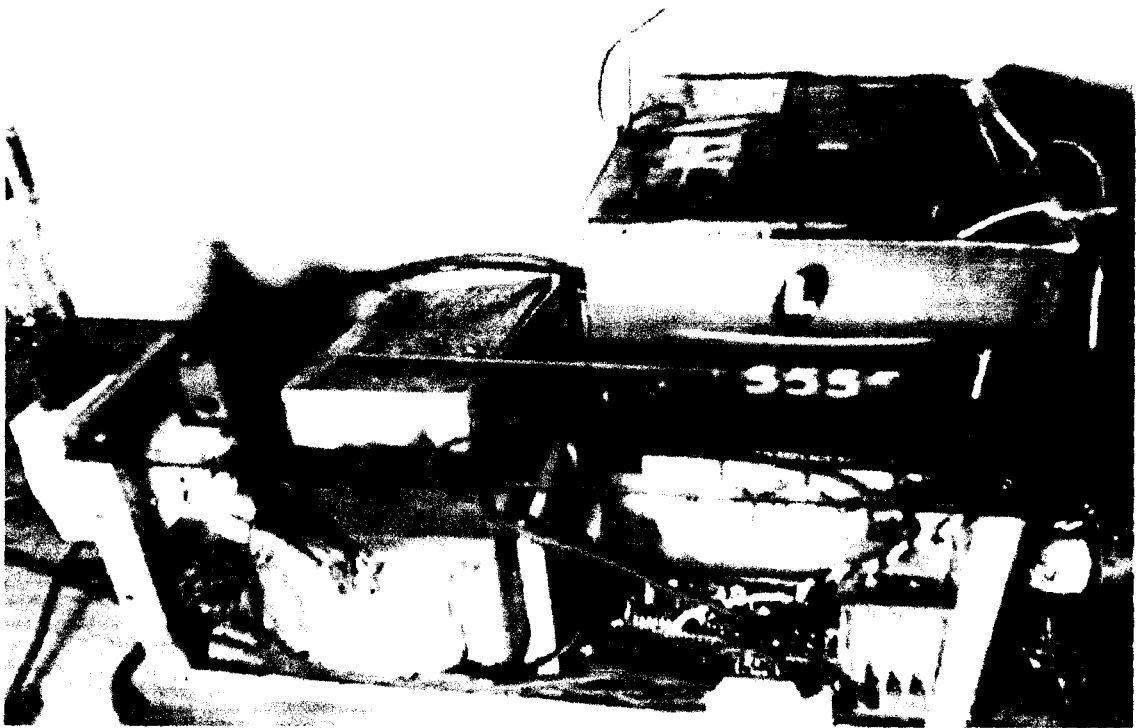

Casing for Solar Inverter

GLOSSARY

- AC - Alternating Current
- DC - Direct Current
- FET - Field Effect Transistor
- MOSFET - Metal Oxide Semiconductor Field Effect Transistors.
- CMOS - Complementary Metal Oxide Semiconductor
- LCD - Liquid Crystal Display
- DIP - Dual Inline Package
- IC - Integrated Circuit
- LED - Light Emitting Diode
- OP-AMP - Operational Amplifier
- SIP - Single Inline Package
- TTL - Transistor-Transistor Logic
- PV - Photovoltaic
- SCC - Solar Charge Controller