

**DESIGN AND CONSTRUCTION OF A
REMOTE CODED ACCESS
SECURITY**

SYSTEM

BY

**ZIBIRI SHEHU TIJANI
99/8424EE**

**DEPARTMENT OF ELECTRICAL
AND COMPUTER ENGINEERING.**

**SCHOOL OF ENGINEERING AND
ENGINEERING TECHNOLOGY.**

**FEDERAL UNIVERSITY OF
TECHNOLOGY, MINNA
NIGER STATE, NIGERIA.**

NOVEMBER 2005.

**DESIGN AND CONSTRUCTION OF A REMOTE
CODED SECURITY
SYSTEM**

BY

**ZIBIRI SHEHU TIJANI
99/8424EE**

**DEPARTMENT OF ELECTRICAL AND
COMPUTER ENGINEERING**

**SCHOOL OF ENGINEERING AND ENGINEERING
TECHNOLOGY**

**FEDERAL UNIVERSITY OF TECHNOLOGY,
MINNA
NIGER STATE NIGERIA**

**PROJECT SUBMITTED IN PARTIAL
FULFILLMENT OF THE REQUIREMENT
FOR THE AWARD OF BACHELOR OF
ENGINEERING (B.ENG) DEGREE IN THE
ELECTRICAL / COMPUTER DEPARTMENT OF
THE FEDERAL UNIVERSITY OF TECHNOLOGY,
MINNA-NIGER STATE, NIGERIA.**

NOVEMBER 2005

DECLARATION

I hereby declare that this project (remote coded security system) work for the award of B.Engr Degree has no bearing to any work done by any person or group of people and a record of my research and practical work was constructed by me under the supervision of Mr. M.A. Saddiq, a lecturer in the department of electrical / computer engineering, Federal university of technology, Minna.

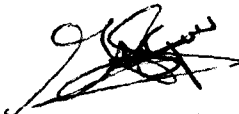

.....

Mr. M.A. SADDIQ

Project supervisor

2/02/05
.....

Date

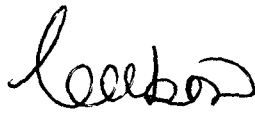

.....

ZIBIRI SHEHU TIJANI

Student

2/12/05
.....

Date

CERTIFICATION

This is to certify that this project **REMOTE CODED SECURITY SYSTEM** was designed by Zibiri Shehu Tijani for the partial fulfillment of the award of Bachelor degree in electrical/computer engineering.

.....

Mr. M.A SADDIQ
PROJECT SUPERVISOR

2/12/05
.....

Date

.....

ENGR. M.D. ABDULLAHI
H.O.D

27/12/06
.....

Date

.....

EXTERNAL EXAMINER

.....

Date

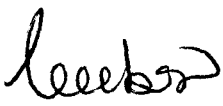
.....

ZIBIRI SHEHU TIJANI
STUDENT

2/12/05
.....

Date

DEDICATION

This project is dedicated to the almighty Allah who saw me through my course of study and especially through this project work, my parents Brigadier General and Mrs. S. Zibiri for their care, assistance both morally and financially and all those aspiring to be electrical Engineers.

ACKNOWLEDGEMENT

First and foremost, all glory goes to Almighty Allah who has guided me, taught me and for his immense grace and protection throughout my academic pursuit.

My profound gratitude goes to my parents, Brig Gen and Mrs. Zibiri who have always been there for me, financially, morally, in every aspect of my life. I thank you so much for your kindness and prayers. This also goes to my brothers and sisters, Dr Zibiri, Mrs. Falilat Kadiri, Ismaila, Ibrahim, Sadiya, Habiba, and Maryam for their love and support during the course of my study.

My profound gratitude also goes to my supervisor, Mr. M.A Saddiq, a man of honour who supervised my project work and gave me professional advice and technical guidance on my project work. He also made time available for me during the period of my critical illness despite is tight academic schedule.

I express my gratitude to our Head of department Engr M.D Abdullahi and all staffs and lecturers in the department for their guidance in the different academic works they taught.

I also express my gratitude to my dear friend Deola Mosebolatan for her kind support and prayer, not forgetting Miss Caroline Onos for her king gesture towards my work.

Finally my sincere gratitude goes to all my course mates, Olisah Agusiobu ,Stanley Ezumezu my Guru, Etito, Mopol, George, Jacob, Akweuze my able class rep, for their firm and unalloyed cooperation and understanding, we were able to work as a bonded team throughout our stay, .May God bless you all in all your endeavors.

ABSTRACT

Remote coded access security systems are used to restrict people from gaining access to a place, equipment, items or database depending on the electronic logic applied to the switching terminal as described here.

To open the system a 3 digit password stored in the group of latches (74374) must be entered in the correct sequence by first resetting the system. The comparator (7845) unit of the system compares the entered code with that already stored in the latches; access is granted if the password corresponds together by switching an electrical device.

The password can also be entered via a remote control which transmits pulses in form of infrared rays and op-amp (LM 393) consisting of the photo diode which receives the transmitted rays, this is enabled by using a 7490 decade counter to count the pulses.

This project has a built in alarm system that consists of two monostable 555 timer, the alarm system signals an intruder, if the codes are entered wrongly three times.

This system finds application everywhere, including banks, military database systems and equipments, conglomerates, schools, etc.

TABLE OF CONTENT

Content	Pages
Title	i-ii
Declaration	iii
Certification	vi
Dedication	v
Acknowledgement	vi
Abstract	vii
Table of content	viii-ix
CHAPTER ONE	
1.0.0 General Introduction	1
1.1.0 Introduction	1-2
CHAPTER TWO	
2.0.0 Literature review	3-4
2.1.0 Project layout	5
CHAPTER THREE	
3.0.0 Design and analysis	6
3.1.0 General overview	6-7
3.1.1 Principle of operation	8
3.1.2 Diode matrix keyboard (input stage)	9
3.1.3 Thyristor latching circuit	10
3.1.4 Alarm circuit	11-12

3.1.5 Power supply stage	13-15
3.1.6 Latch control stage	16
3.1.7 Latch comparator stage	17
3.1.8 Counters	18-21
3.1.9 Other passive components	22
3.2.0 IC Timers	23-27
3.3.0 Construction, Testing and result/ Inference	27
3.3.1 Construction	27-29
3.3.2 Project casing	29
3.3.3 Testing	30
3.3.4 Result	30
CHAPTER FOUR	
4.0.0 Conclusion and recommendation	32
4.1.0 Conclusion	32
4.2.0 Recommendation	33
Reference	34

CHAPTER ONE

1.0.0 GENERAL INTRODUCTION

1.1.0 INTRODUCTION

Electronic systems refine, extend or supplement human facilities and ability to observe, perceive, communicate, remember, calculate or reason. Electronic systems are classified as either analog or digital.

Analog systems change their signal output linearly with the input and can be represented on a scale by means of a pointer. In the other hand, digital instruments or circuits, represent their output as two discrete levels ('1' or '0') and could show their output in a digital display either numerically or alphabetically.

Digital systems in general are more legible (in terms of output) and are more precise and accurate since their output always maintains two discrete levels.

The digital coded access security system is an electronic device in which a particular code is programmed on the device and any user will have to enter that code via a keyboard or remote control to gain an access to particular equipment with an appropriate interface circuit. The equipment might be electronic in nature, a door lock or any electromechanical device that suits the objective of the project.

In this case the system is designed to work with electronic equipment, in which the interface will be via a relay to the particular equipment, wiring will be specially done such that the equipment cannot be easily removed and plugged to another socket.

The system uses a remote control which sends pulses in the form of infrared rays to the receiver to encode data to the system. The encoded data is compared with the

programmed data and if they are the same, access is granted by sending a high to a switching circuit which controls an interface system. A group of parallel latches hold the various codes and another group of digital comparators will compare the codes with that of the programmed code and give an output which will switch a secondary element (e.g. a relay or solenoid) to control an electrical or electromechanical device.

The unit finds place almost everywhere, in schools, banks, or offices etc. the system could as well be used to code computers used in the various departments to avoid fraud and other malpractices.

CHAPTER TWO

2.0.0 LITERATURE REVIEW

The earliest lock in existence is an Egyptian lock made of wood, found with its key in the ruins of Nineveh in ancient Assyria?

In construction it is the proto type of the modern cylinder lock. Locks and keys are also mentioned in the Old Testament, and the Greeks and Romans used locks of simple design. Medieval artisans designed locks of exquisite detail, the perforations and curvings often having no relation to the working of the lock. With the exception of the development of ward locks, however, little was done to improve the efficiency and convenience of locks until the late 18th century.

In the 19th century locks, keyless locks and electronic locks were invented and improved. Subsequent development has resulted in mass production, improvement of materials, and increasing complexity of the working mechanisms, including the increasing use of automatic electronic alarm and safety devices.

The principle of locks in the advancement in technology made machine tools, computer systems, electronic devices and manufacturing methods become more sophisticated, locks were produced with closer part tolerance resulting in better security. Locks were later combined with coding systems and alarm systems that automatically signals an intruder if the codes are entered wrongly.

In 1883 George Lush person applied for a patent for his invention which would alarm by means of electric communication. This was initially a revolving lamp in the exterior of the protected premises or the use of bells. It was not until 1923 the intruder alarm became generally available. Since that time, lock equipment has been designed

which uses the principle of ultrasonic, microware, infrared light, television current monitored wiring, magnetic recorders, vibration sensors, capacity sensors, microphone, many type of switches and electronic security systems.

Today new security technologies threaten the dominance of mechanical coding systems and key locks. The key card developed in the early 1980s for the use in the hostels, is a small credit card that holds coded information that is magnetically imprinted allowing a guest to enter the room or device. The code is changed when the person checks out of the room or stops using the electronic device. The keyless coding systems are the most recent of the modern locks, they include card operated lock, electronic lock and Remote coded lock which his protect is all about.

The locking system is interfaced with an electronic device or computer systems. The technique developed to protect single computer systems and networked – linked computer systems from accidental or international harm. Such harm includes destruction of computer hardware and software loss of data, and the deliberate invasion of databases and applications by unauthorized individuals.

Data may be protected by such basic methods as locking up terminus and replicating data in other storage facilities. More sophisticated methods include limiting data access by requiring the user to have an encoded card or to supply an identification number or password, to be able to open that device or electronic system for use.

Humanity owes its present relatively comfortability standard of life and expectation of further advancement to security. The process of security changes have been going on for millions of years and will continue due to the advancement in technology.

2.1.0 PROJECT LAYOUT

This project write up is divided into four chapters for easy comprehension of what the project is all about.

Chapter one consist of the introduction which present a brief insight to the main concepts behind the work, the aim and objective of carrying out the project work.

Chapter two consists of the literature review which shows previous or related work that have been done on this project and the project outline showing the division of the project work into chapters.

Chapter three consists of the design and analysis which gives a clear description of the step by step design of the project work with the aid of diagrams with clear explanations. It also consists of the working operation which shows the [principle on which the device works on and how to use it, the construction aspect, the testing and result/inference. in this chapter all the technique used in combining the different IC components and the passive component to the realization of the circuit diagram of the project work was discussed. Testing procedures as well as result and inference deduced from the test performed were also discussed in this chapter.

Chapter four, the last chapter of the project consists of the recommendation which provide suggestion for the improvement of the design work and conclusion which shows what have been achieved from doing the project work.

CHAPTER THREE

3.0.0 DESIGN AND ANALYSIS.

3.1.0 GENERAL OVERVIEW

In this project design, complementary metal oxide semiconductor (CMOS) integrated circuits (ICs) were chosen for all the ICs used because of its wide operating voltage of between + 3Vd.c to + 18Vd.c, and its reduced power consumption. Also CMOS devices do not need the voltage to be closely regulated as its transistor-transistor logic (TTL) counterpart.

The circuit is a digital circuit as against an analogue circuit, since digital circuits are used as switching circuits where exact values of voltages and currents are not important, only the range (HIGH or LOW) in which they fall. Information storage is also easy. This is accomplished by special switching circuits that can onto information and hold it for as long as necessary.

The low power consumption of this device makes it to be powered from a battery since it does not make unusual demand on power supplies because of its minimal requirement for supply current (only a few microampere on quiescent state). This battery is required in case of power outage making it reliable.

In order to analyse the entire circuit, it was broken down into ten broad subsystems namely, input unit (Dot matrix keyboard), Thyristor latching circuit, Alarm circuit, power supply stage, latch control stage, latch / comparator stage, counters, passive components, IC Timers and Remote control unit. Each of these subsystems was further divided into modules to ease design and enhance simplicity.

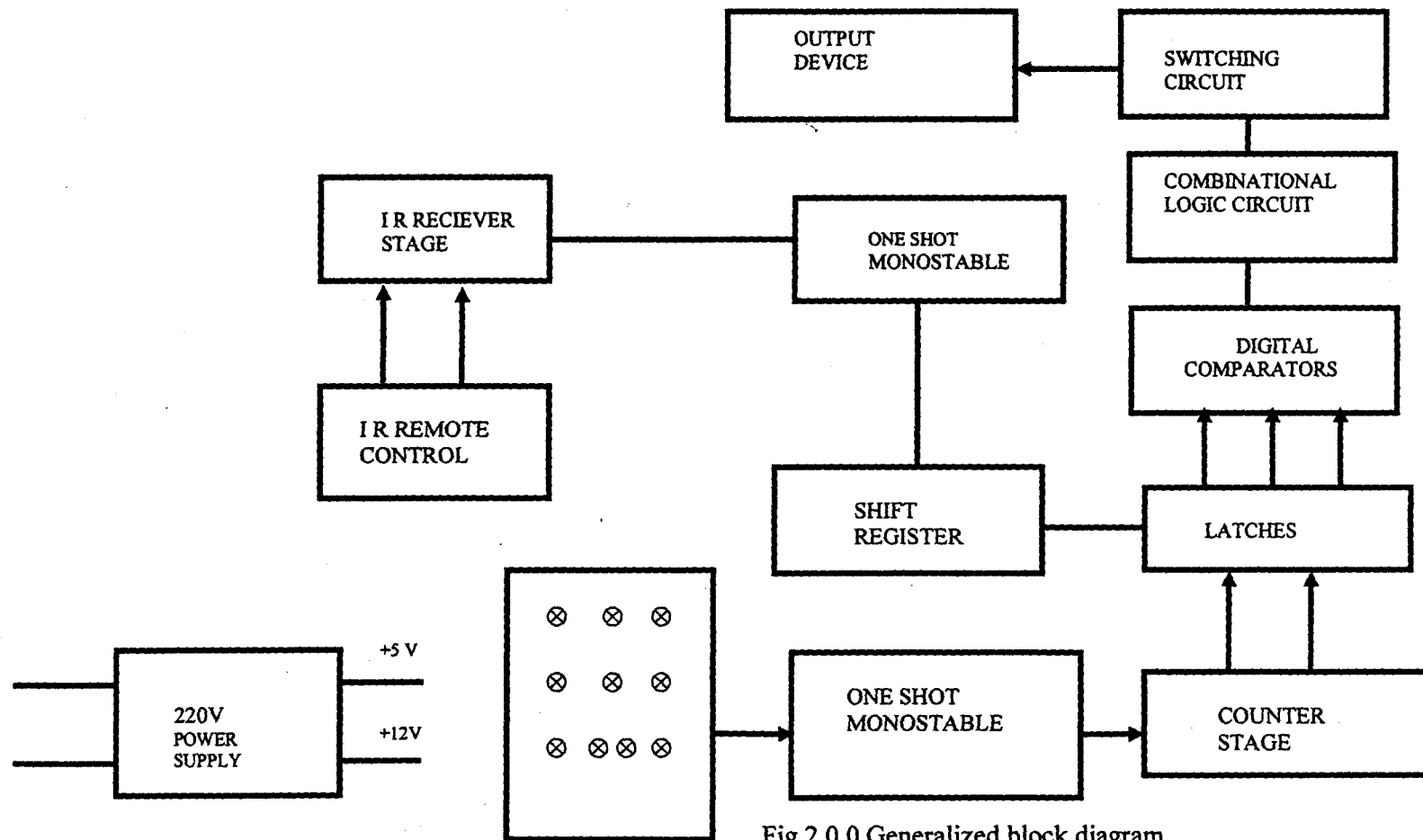

Fig 2.0.0 Generalized block diagram

3.1.1 PRINCIPLE OF OPERATION.

The operation of the system involves coding the system with a 3-digit pass word, and entering a three digit number to gain access to the system. If the encoded number is the same as that of the preset code, access is granted, and power is supplied to the equipment.

The diode matrix keyboard is used to enter binary data to the series of latches (wired in transparent mode), and enabling is done using a one-shot monostable stage. The stored data is preset in the magnitude comparator stages. The data is fed to the input of all the latches and enabling of particular latches is done from the shift register.

Once data is stored in the latches the stored data is compared with the already preset data in the magnitude comparators, and the output of the comparators go to a four input AND gate, which gives an output if all inputs are high. The output is fed to a switching circuit (in this case, a thyristor switch) which controls a secondary device, which might be a motor opening a door or a relay switching power to an electrical device. Isolation of mains from the circuit is done using the relay since the relay contacts are electrically isolated from the coil. The various stages and modules are analyzed below.

3.1.2 DIODE MATRIX KEYBOARD.

The diode matrix keyboard is designed using a diode matrix arrangement to achieve equivalent BCD or binary output for respective inputs. Fig 3.1.2 below shows the circuit of the diode matrix keyboard.

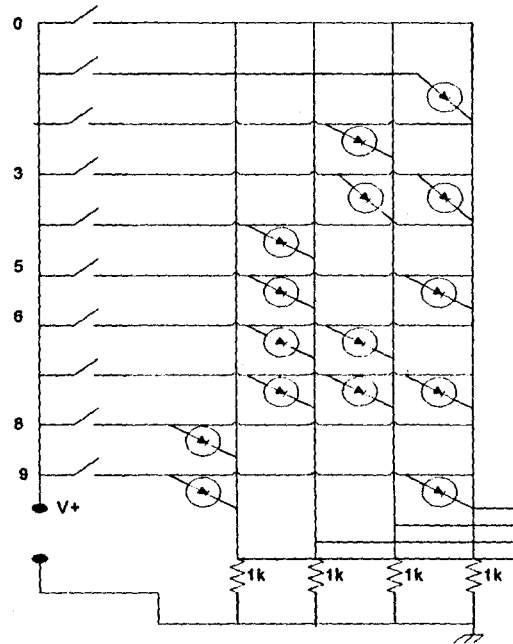

Fig 3.1.2 diode matrix keyboard.

3.1.3 THYRISTOR LATCHING CIRCUIT.

The thyristor stage, once triggered by the switching circuit, latches a high voltage in its cathode. The output of the cathode is used to power a delay monostable which in turn triggers an alarm circuit.

The timing process can be aborted or reset, by resetting switch S1 (which is a normally closed switch in the thyristor anode). Fig 3.1.3 shows the circuit of this stage.

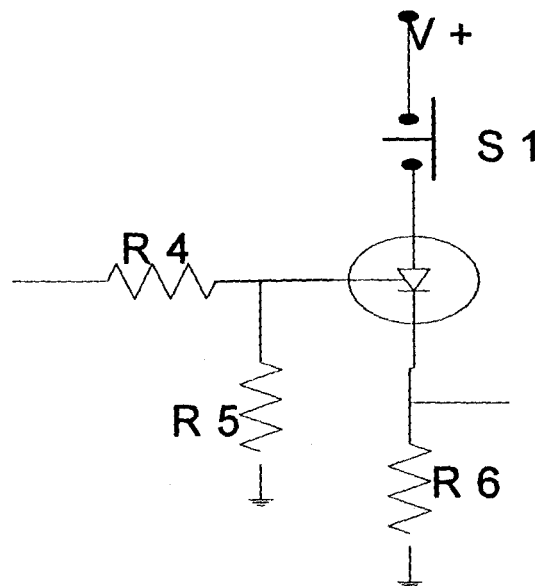

Fig. 3.1.3 Thyristor switching/latching circuit.

The gate voltage required to switch the thyristor to forward conduction is always indicated in the data sheet. The thyristor gate voltage V_{GT} in this case is 2V (from data sheets) hence, since the output of the transistor switch gives +12Vdc; we want the drop across R5 to be 2V

$V_{R5} = 2V$, and $V_{in} = 12V$,

$$\text{But } V_{R5} = \frac{R5 \times V_{in}}{R4 + R5}$$

Now letting $R5 = 1k$. Gives $R4 = 5K$ (4.7k preferred value).

Upon switching the thyristor 12V is dropped across R6 and remains there until the resetting occurs by switching depressing S1. The reset switch is placed in a secret place only where any authorized user of the device would see it.

3.1.4 ALARM CIRCUIT.

The alarm circuit is a two tone siren type alarm. It falls under the category of security alarm systems. To scare the supposed intruder and also to alert passers by that there is a problem with the particular system. The alarm circuit is a combination of two astable multivibrators. The astable oscillates at different frequencies of which one is used to modulate the other. Modulation is achieved from pin5 (control voltage). For normal astable operation pin 5 goes to zero via a capacitor of $0.01\mu F$ but if a voltage of between 45% and 90% of V_{cc} applied is applied to the to pin5, frequency modulation occurs.

Coupling the voltage via a capacitor creates a kind of warble tone, due to the charging and discharging of the battery. Fig 3.1.4 shows the circuit of the two tone alarm.

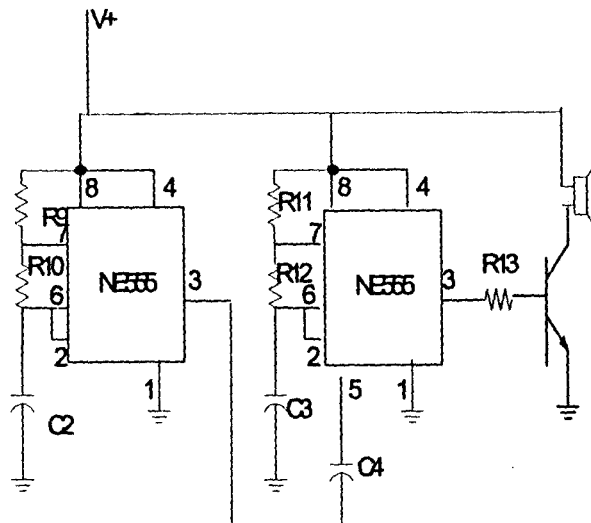

Fig 3.1.4 two-tone siren.

The first monostable is used to modulate the second which generates a constant tone. The warble effect is achieved by coupling the modulating signal via capacitor C4. For the first monostable a frequency of 3Hz is generated.

DESIGN CALCULATIONS;

$$t_1 = 1.1C(R_1 + R_2) \text{ seconds (where } t_1 = \text{ON time)}$$

$$t_2 = 0.693CR_2 \text{ seconds (where } t_2 \text{ is the OFF time)}$$

$$\text{Since } F = \frac{1}{T}$$

$$\& T = t_1 + t_2$$

$$F = \frac{1}{\ln 2C(R_1 + 2R_2) \text{ seconds}}$$

$$F = \frac{1.44}{(R_1 + 2R_2) C} \dots\dots\dots (1)$$

Letting $R_1 = 10K$ and $C = 100\mu F$ for $F=0.5Hz$ (for the modulating astable)

Substituting the values into equation 1

$$R_2 = 9.4K$$

For $F=1 KHz$, letting $R_1=47K$ and $C=10nF$ (for the tone generator stage)

Substituting values to equation 1 gives $R_2=48.5K\Omega$

A variable resistor of $100K$ was however used.

3.1.5 POWER SUPPLY STAGE

All stages in the project uses $+5V$ except the transistor stage that controls the relay, which uses a voltage of $+12V$ and of course the transmitter stage which uses a $9V$ battery. The power supply stage is a linear power supply type and involves in step down transformer, filter capacitor, and voltage regulators. To give the various voltage levels.

The power supply circuit diagram is shown in fig. 3.1.5a

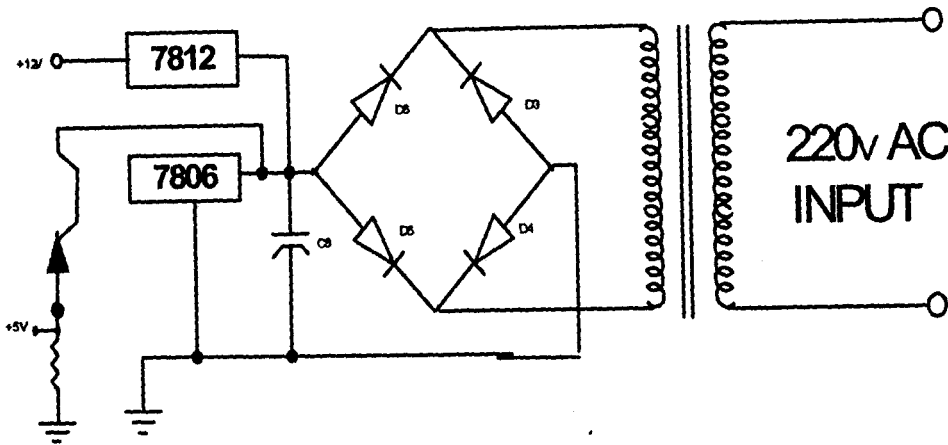

Fig 3.1.5a power supply circuit

The rectifier is designed with four diodes to form a full wave bridge network. C_1 is the filter capacitor and C_1 is inversely proportional to the ripple gradient of the power supply. Fig. 3.1.5b shows the ripple gradient

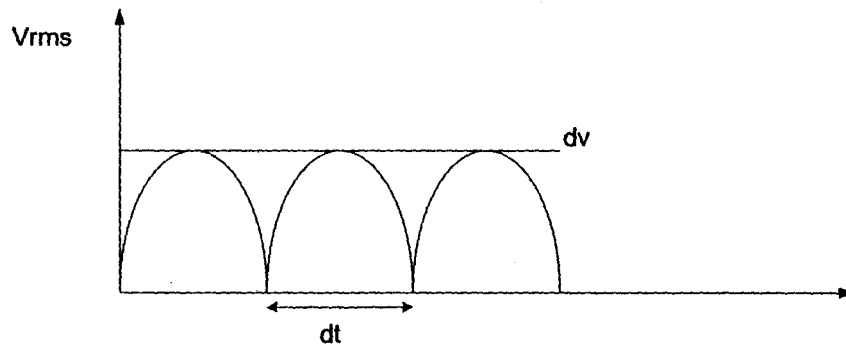

Fig. 3.1.5b ripple gradient of power supply stage.

Where dv is the ripple voltage for time dt , where dt is a dependent in power supply frequency.

For an rms voltage of 15volts (from transformer)

$$\begin{aligned}V_{\text{peak}} &= 15 \times \sqrt{2} \text{ (i.e., rms } \times \sqrt{2}) \\ &= 21.2\text{V}\end{aligned}$$

Hence letting a ripple voltage of 15% makes $dv = 3.18$

$$\text{But } \frac{1}{C} = \frac{dy}{dt}$$

$$C = \frac{dt}{dv}$$

$$= \frac{10\text{ms}}{3.1\text{v (where } dt = 10\text{ms for } 50\text{Hz)}}$$

$$= 3225.8\mu\text{F}$$

A preferred value of $3300\mu\text{F}$ was employed for the power supply stage.

IC6 & IC35 are 7806 and 7812 regulators respectively to generate +6 and +12, the transistor TR3 that is a buffer and drops 0.7V (V_{BE}) to reduce the +6 to 5.3V, which is approx. +5V.

3.1.6 LATCH CONTROL STAGE.

The latch control sends the latch enable signal to enable the latch. The 74373 latch used in this project is enabled by a LOW level signal. This is achieved by using a NOT gate to invert the output of the shift register. Fig.3.1.6 shows the circuit of this stage.

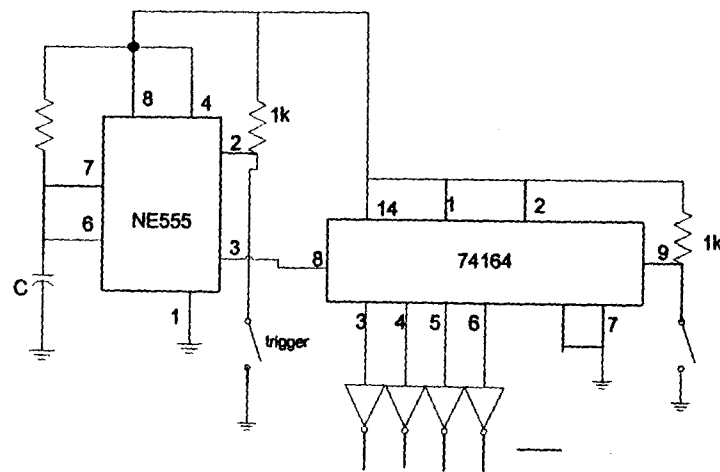

Fig 3.1.6. Latching control circuit.

DESIGN CALCULATIONS.

Since $T = 1.1 RC$,

For $T = 1s$, and letting $C = 100\mu F$,

$$R = \frac{1}{1.1 \times 100\mu F}$$

$$= 9.09k$$

= 10k preferred value.

Hence the monostable of IC4 has $R = 10k$, and $C = 10\mu F$.

For the second monostable, IC5 is designed for 10s, using the same design calculations, the value of R and C becomes 100k and 10 μ F respectively.

3.1.7 LATCH/ COMPARATOR STAGE.

The latch and digital comparator stage is where the password (3 - digit code) is set. The codes are set in one of the comparator 4bits input and the other inputs are connected to their corresponding latches. Changing the binary inputs to the comparators does not change the password. Fig. 3.1.7 shows the comparator and latching circuit.

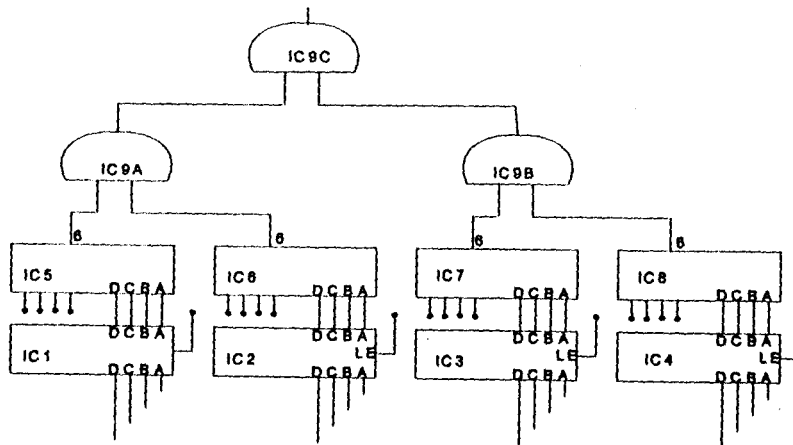

Fig 3.1.7 latching and comparator stage

The encoder stores all the data into the latches with the aid of the shift register. If the data fed in is equal to that stored in the comparator, the comparator gives an output of 1. If all the data is correct, all the comparators will output 1, and will send a 1 to a transistor switching circuit via a 3-input AND gate. The switching circuit will control a relay interface circuit which will switch power OFF an electrical device.

3.1.8 COUNTERS

Grouping of flip-flops together so that they act as a data store produces a register. Certain types of register can be used to count pulses and are known as counters. Flip-flops generally may be used to form counters but the JK flip-flop is the most popular and most flexible to use.

Counters generally are categorized to Asynchronous (ripple) and synchronous. They are made up of flip-flop, which are triggered sequentially (as in the case of Asynchronous counters) and simultaneously as in the case of synchronous counters. The simultaneous triggering of the ripple counter is useful in cases, which the propagation delay associated with ripple – through counter may be a problem.

ASYNCHRONOUS COUNTERS

Consider the three-stage counter using JK flip-flops connected in toggle mode shown in fig. 3.1.8a below.

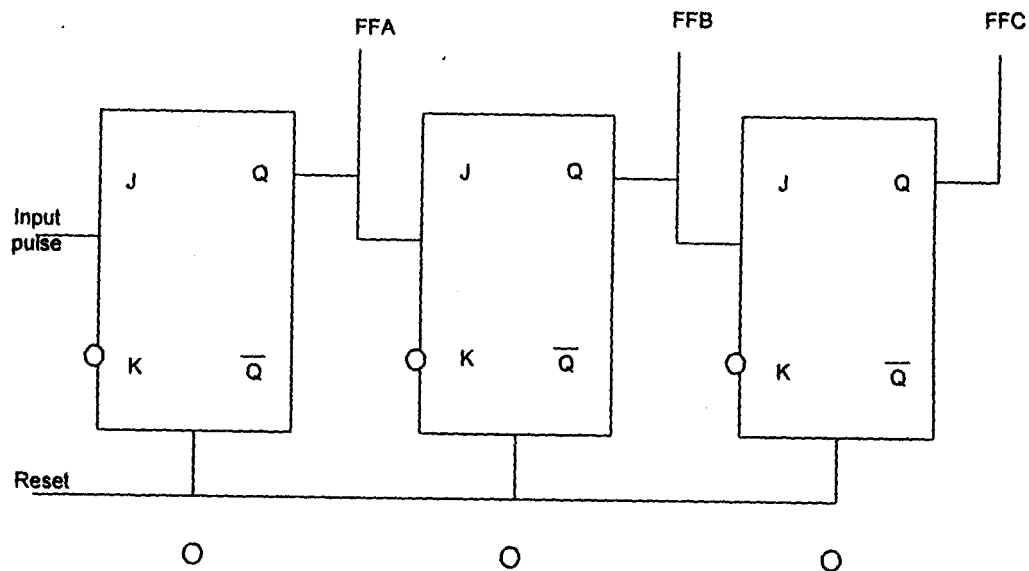

Fig. 3.1.8a asynchronous counters

If all outputs and initially reset to zero by an input going low in the clear line prior to the input signal arriving and the JK flip-flops are master-slave then the input pulse to flip-flop A (FFA) will have no effect on the QA output until the pulse changes from logic 1 to logic 0 level. However, the output QB reset at 0 since the input pulse to flip-flop B (FFB) has gone from 0 to 1. Similarly, QC will remain at 0.

When the second input pulse has arrived and gone from logic 1 to logic 0. However, this is a negative transition and as such will cause the output of (FFB) to toggle so that QB goes to 1. Since this is a positive transition QC will be unaffected and remains at 0.

At the end of the third input pulse, QA again toggles; this time to logic 1 QB and QC retain their values of 1 and 0 respectively. At the end of the fourth input pulse, QA toggles

and falls to 0. The transition from 1 to 0 at the input to FFB causes QB to fall to 0 and this transition in turn causes FFC to toggle so that QC goes to 1.

This procedure repeats until the output completes the cycle and resets should the pulse signals at the input still be present.

The modulo of a counter is the total count it provides. The counters so far described can count from zero to seven inclusive and are known as modulo 8 counters.

The count of 8 is produced from three stages (since $2^3 = 8$).

Similarly a counter of 2 could be produced by one stage ($2 = 2$) and a count of 16 by 4 stages.

The modulo 10 counter or otherwise the decade counter is very important since this is required in the conversion of binary counts to the seven segment display.

In cases where modulus of counters are required and problems of unwanted count or bits arise alternative method using feedback and dividers are used.

So far we have designed Asynchronous counters using the flip-flops in the toggle mode with the single input to be counted brought to the clock input of the least significant bit (LSB) and the output stage used to clock the next stage. This design seems to be error free but could give rise to errors if a special count value is required of the counter. For cases such as this a commercial counter with reset is recommended.

A commercially available counter is the 7490 which is been used in this project. This circuit is internally divided into two sections giving a $\div 2$ and a $\div 5$ representation. The IC pin is shown in fig 3.1.8b

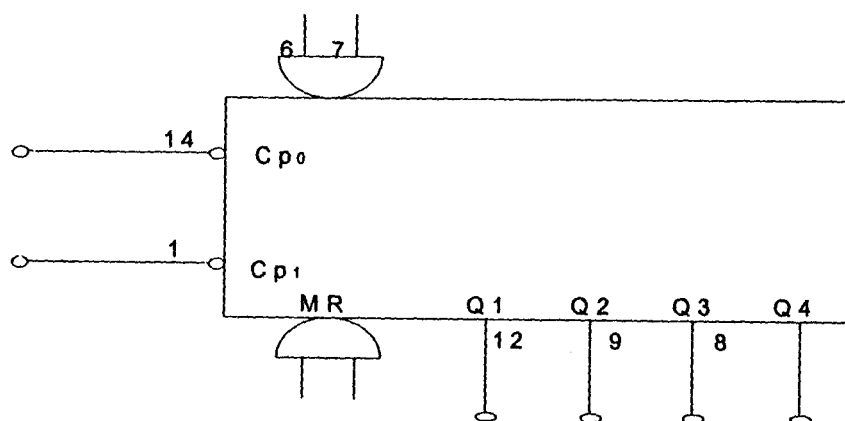

Fig 3.1.8b 7490 Decade counter

The 7490 counter when used as BCD counter or an equivalent decade counter could be cascaded to give larger decimal counts. Suppose it is required to build a counter to count from 000 to 999 before units being used to clock the next count, which represents tents. The QD output of the tents counter would likewise be used to trigger the 7490 to

be used to count hundreds. The arrangement is shown in Fig 3.1.8c cascaded 7490 decade counters

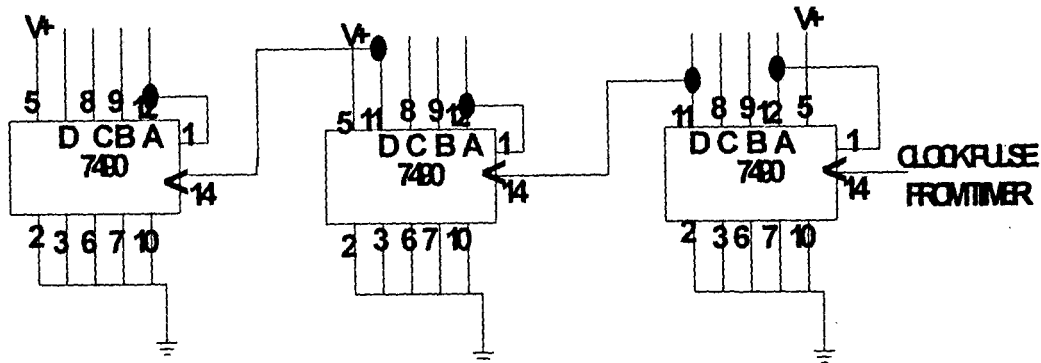

Fig. 3.1.8c cascaded decade counters.

Each of the counters can count from 0 to 9 and in the case of the units counter, once the count is complete a carry is passed to the next (tens) counter so that a count of ten is recorded. The units count continues to count up to 9 and when resetting produces a count of 20 (2 on the tens counter and 0 on the units counter). Via a suitable decoder the BCB output of each counter could be used to derive a display element such as an LED seven-segment display, gas-discharge etc. so that a direct visual output can be obtained.

Other types of commercially available counters exist like the 4 – bit binary counter (7493), presettable up-down counters (74192), GRAY CODE COUNTERS, EXCESS 3 COUNTER, e.t.c. (For further details on counters, consult RS Maddock – Electronics a course for Engineers pg (241 – 277).

Synchronous counters are left out since they are not of relevance to our scope of work.

3.1.9 OTHER PASSIVE COMPONENTS

Passive components are components, which cannot amplify power and require an external power source to operate. They include resistors, capacitors, diode, indicators, and transformers etc. their application range from potential dividers to control of current (as in resistors), filtration of ripples voltages and blocking of unwanted D.C voltages (as in capacitors). They form the elements of the network circuit oscillator stages and are also used generally for signal conditioning in circuits. Their schematic diagrams and symbols are shown in Fig 3.1.9a-d below.

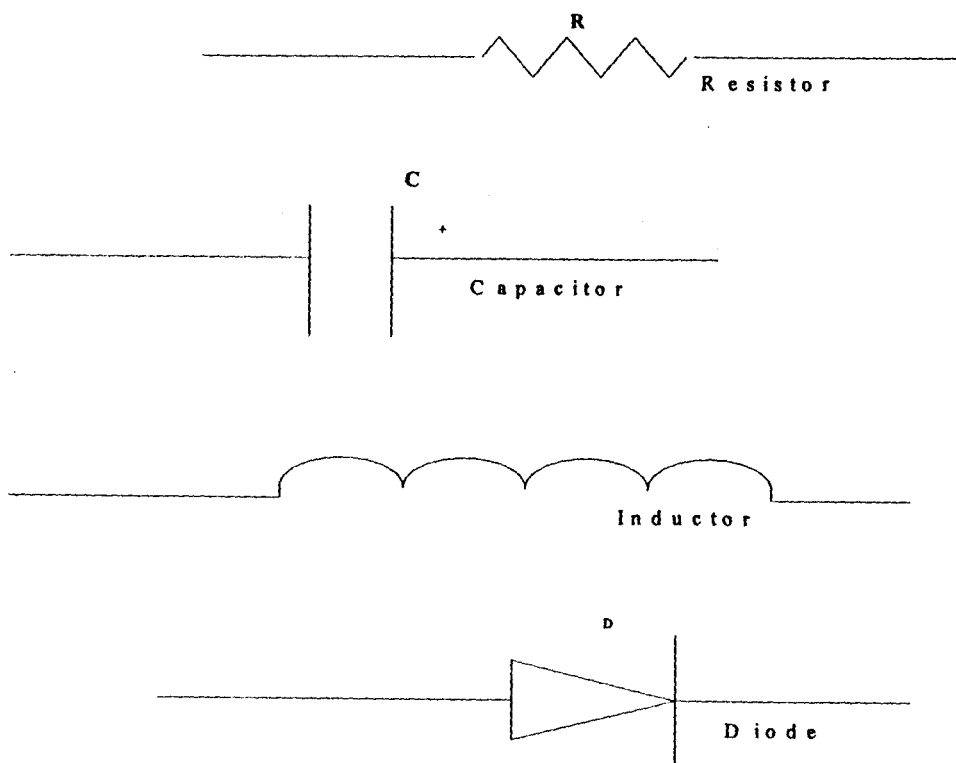

Fig3.1.9a-d schematic representation for passive components.

3.2.0 IC TIMERS

Timing circuits are those which provide an output change of state after a predetermined time interval. Timing circuits could be modified to function as Monostables, Astables and Bistables. The emanation of IC timing devices. The most popular of the present IC timers is the 555 timer, which is available in an eight pin dual in line package, in both bipolar and cmos forms. The 555 timer comprises of 23 transistors, 2 diodes and 16 resistors in its internal circuitry. Its functional block is shown in Fig 3.2.0a

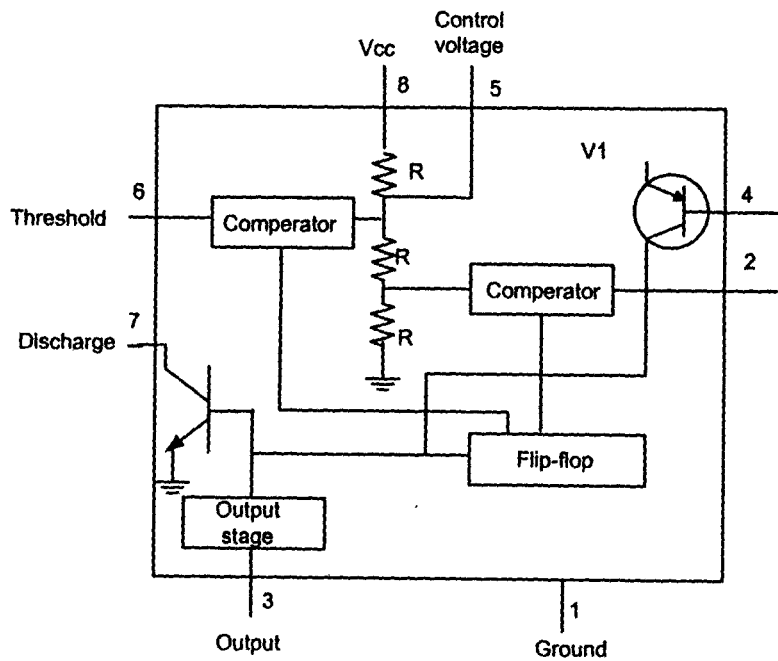

Fig 3.2.0 a 555 Timer (internal) block diagram

The functional block diagram consist of two comparators, a flip – flop,two control transistors and a high current output stage.

The two comparators are actually operational amplifiers that compare input voltage to internal reference voltages which are generated by an internal voltage divider chain of three 3kΩ resistors. The reference voltages provided, are $1/3 V_{cc}$ and $2/3 V_{cc}$. When the input voltage to either of the comparators is higher than the reference voltage for that comparator, the amplifier goes into saturation and produces an out put signal to trigger the flip – flop. The output of the flip- flop controls the output stage of the timer. Below shows the pin configuration of the 555 timer.

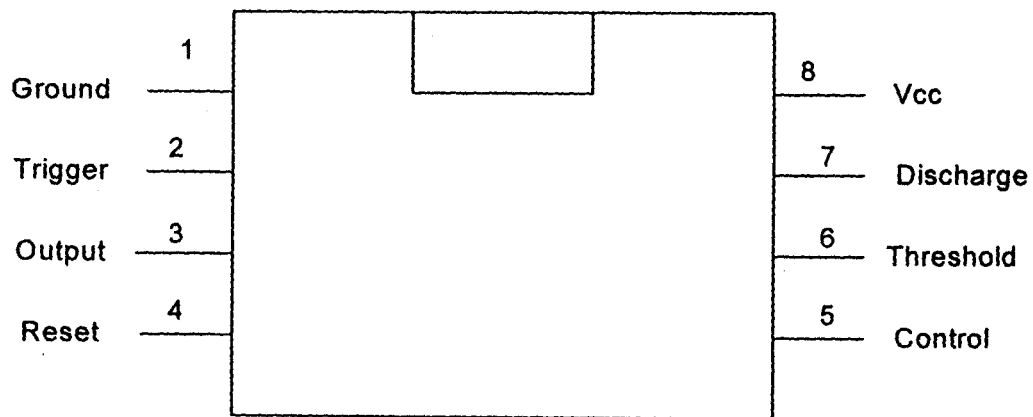

Fig 3.2.0b 555 timer pin orientation.

The 555 timer chip works from a d.c supply of 3 – 15v and can source or sink up to 200mA at its output.

The astable operation produces free running pulses which could be used as an oscillator and can give frequency output in the range of a fraction of 1Hz to 1MHz. The oscillator output give square wave pulses as shown in Fig 3.2.0c

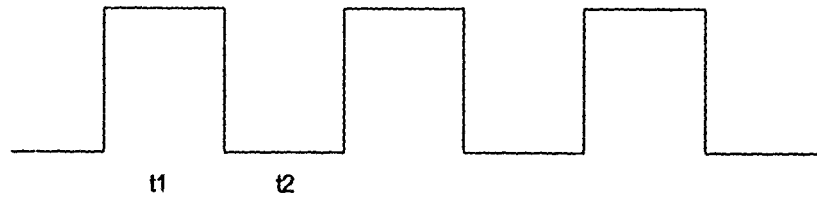

Fig 3.2.0c Square wave pulses of the 555 timer.

where t_1 is the ON time and t_2 is the OFF time.

$$F = \frac{1}{T} \quad (\text{where period } T = t_1 + t_2).$$

But,

$$t_1 = 0.7 (R_A + R_B) C,$$

$$t_2 = 0.7 R_B C$$

hence,

$$F = \frac{1.44}{(R_A + 2R_B) C}.$$

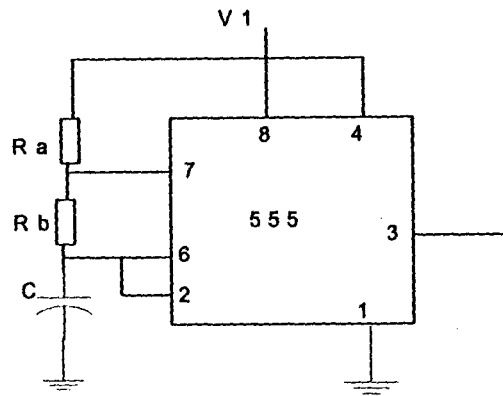

Fig 3.2.0d typical astable 555 timer configuration

fig 3.1.9e below shows the monostable mode connection, sometimes referred to as a one shot, used basically for timing purposes.

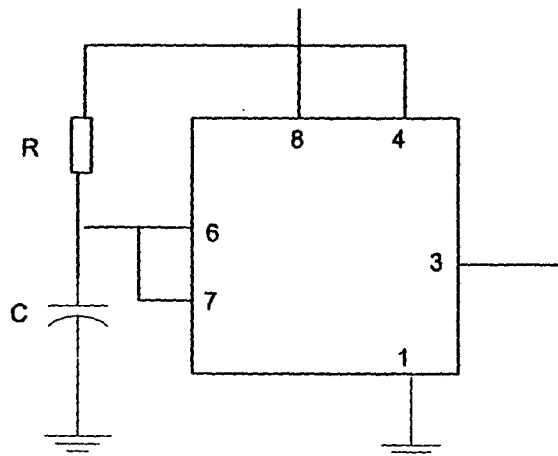

Fig 3.1.9e monostable mode of the 555 timer

In the monostable mode, only one external resistor R is required and threshold (pin 6) is joined to the discharge (pin 7).

A rectangular pulse is produced when the trigger signal is applied to the trigger input. The monostable is triggered by the falling (negative going) edge of an external pulse. It then returns to its one stable state (low output) to await the next trigger pulse. The trigger pulse must be $< 1/3V_{cc}$, for timing to occur. The time duration of the trigger pulse must be less than the output pulse time. The time for the output pulse is given by $T = 1.1RC$.

3.3.0 CONSTRUCTION, TESTING AND RESULT / INFERENCE

3.3.1 CONSTRUCTION

In the construction work the manufacturer's data sheet of the different ICs transistor used for this project were studied to know about each pin and the different functions they perform and how to connect them.

The construction involves three stages, the initial stage was the construction of the project on the breadboard. This involves the arrangement of the components according to the circuit diagram giving attention to the polarity of polarized components (such as diodes, LEDs, transistor and electrolytic capacitor) on the breadboard. The circuit was powered using a 12v d.c supply with a 12v battery backup cell. This is to check that the circuit diagram is working as designed, before transferring the components to the Vero board.

The second stage was the transferring of the components in unit to the Vero board to ease construction work and to help detect fault if any one arise. The second stage involves planning a rough layout of the project on the Vero board using paper to show how and where the components making up the project work are to be mounted on the Vero board.

In planning the layout physical proximity of these components and the multiple constructions required between integrated circuits (ICs) and other passive components were considered so as to effectively minimize the number and size of wire links. The Vero board was cut into two sizes, one for the power unit and the other for the remaining components making up the access system taking into consideration the components spacing and clearance between components to avoid fault. The mounting of the diodes, electrolytic capacitor and the transformer forming the power unit were done to its Vero Board taking note of the polarity of the electrolytic capacitor, diodes and LEDs and the primary side and the secondary side of the transformer. This was then compared with that of the circuit diagram and soldered. The other IC components and the passive components forming the Remote access were also mounted using IC sockets for ICs that are prone to fault from excessive heat from the soldering iron. This was also compared with the circuit diagram taking note of the polarities of the LEDs and the power supply to the ICs.

The third stage was the soldering. Soldering was performed with due regard to safety. It was carried out using a low voltage soldering iron, operated from a transformer connected to the mains. A hot soldering iron is essential if good solder joints are to be produced. The hot soldering iron was placed so that it touches both the soldering lead and the terminal to be soldered. These steps were repeated for the soldering of each passive components, IC chips and IC sockets to the Vero board. Over heating of the joint (terminal) was avoided because it could damage the components being soldered and also soldering of bridge linking tracks together was avoided.

Flexible wires were then soldered to link to the different components that form the circuit together while referring to the manufacturer's data sheet and to the circuit

diagram so that all components were properly connected the right way round. On completion, the Vero board was carefully checked for any loose leg not soldered properly and for any wrong connection of polarized components.

The circuit was tested before it was fixed onto the device by entering the password code to open the system and testing this password code and wrong password codes, so as to rectify any problem before it is fixed to the device.

3.3.2 PROJECT CASING

A metal casing was used for the construction of the project because of its availability, space, ease of drilling holes, its physical outlook and ease of modification.

In construction of the project, the push buttons were placed on the casing to ease access and the interface properly mounted to ease connection to devices .

3.3.3 TESTING

The device which is a multi-purpose system was tested after construction to check if the circuit is working according to the design. The devices was tested as follows ;

- 1) When the device was connected to the power supply the wrong password was entered.
- 2) With the device still powered and the reset button pressed and released, the right password was entered.
- 3) With the device still connected to the power supply the access system was locked and the wrong password was entered three times and then the right password was entered without pressing the reset button

- 4) The reset button) was pressed and released and the right password was entered.
- 5) With the right password entered and the light emitting diode ON the password was changed by pressing and releasing the reset button) was pressed and released after the third decimal number to be used as password has been entered and the steps 1-3 above were repeated for the new password.
- 6) Lastly the access system was locked and the reset button was pressed and released to store another new password and this new password was entered to open the lock.

3.3.4 THE RESULT

The following results were obtained for the tests, as stated in section 3.3.3 above.

- 1) When the system was powered on and the wrong password entered, the access system was locked.
- 2) With the second step, the access system opened when the right password was entered.
- 3) With the third step, an alarm was raised when the password was entered wrongly 3 times.
- 4) With the fourth step, the access system opened.
- 5) For fifth step, when the password was changed the access system still opened.

CHAPTER FOUR

4.0.0 CONCLUSION AND RECOMMENDATION

4.1.0 CONCLUSION

From the foregoing section it can be seen that the design and construction of a Remote coded access security system, just like any other project work requires planning and implementation. This project work has been a very challenging task. The project has given me the opportunity of getting a better understanding of some basic electronic principle and implementing practically .The problem of getting the necessary textbook for research construction and report write up had to be contented with. Even with this most of the construction and project write up was carried out through painstaking research.

The design and construction of the Remote coded access security system has successfully being constructed as explained in chapter three of this project write up. From the various test carried out and the result obtained, it has shown however that the aim of the project as stated in chapter one of this write up has been achieved and since the principle used for the project worked accordingly to specification and quite satisfactory.

The remote coded access security system is relatively affordable reliable, uses low power consumption, easier to operate and provide high level of security.

Its multi-purpose ability distinguishes it from other types of security access system as it can be interfaced with an electronic device via a parallel port.

4.2.0 RECOMMENDATION

The following suggestions are given on the project work generally and Remote coded access security system in particular.

- (1) I recommend that the department should help students in their project work and that project should be given to student before they go on the Industrial Attachment program so as to make them have broader view and research widely on their project.
- (2) I also recommend that this project Remote coded security access system be used in, multinational companies, Banks, Schools, Military System, Tertiary Institutions.

Since the design can still be improved on, the following suggestions listed below were made to serve as a basis (guide) for further research in this project in the improvement of this project design work.

- (1) A voice recognition system can be included into the circuit; this enhances the security capability of the device. It works on the principle that the device has the Artificial intelligence to ask for a passcode, the system opens with the correct passcode entered.
- (2) An interface with a parallel port can be incorporated with a special program used to run it. This aids the device to be interfaced with electronic devices that uses parallel port e.g. computer systems, printers Routers etc.

REFERENCES

- 1) B.L THERAJA and A.K THERAJA. a textbook of electrical technology, 21st edition, Ranjendra Ravida printer Ltd., New Delhi-India, 2002, pp822-826, 919-930, 1673-1676.
- 2) EWARD HUGHES, Electrical technology, 7th edition, Longman group publishers Ltd., United Kingdom, 2002 pp461-463, 668, 673-675.
- 3) <http://www.motorola.com>
- 4) <http://www.onsemi.com>
- 5) LEN JONES, Basic electronics for tomorrow's world, 2nd edition, The press syndicate of the university of Cambridge England, 2002, pp232-236, 241-260, 309-320.
- 6) PAUL HOROWITZ, WINFIELD HILL, The art of electronics, 2nd edition, Cambridge University press, United Kingdom, 2002 pp20-21, 44-46, 53-57, 63-64, 284, 471-480, 486, 504-510.
- 7) R.J MADDOCK and D.M CALCUTT. Electronics; A course for engineers, 2nd edition, Longman group publisher Ltd., United Kingdom pp232-236, 241-260, 309-320
- 8) R.J TOCCI and N.S WIDMER. Digital system: Principles and application, 7th edition, V on Hoffman press Inc. New Jersey, USA, 2002, pp183-205, 220-226, 340-344, 361-363, 383, 512-523.
- 9) TOM DUNCAN, Success in electronics, 2nd edition, John Murray (publisher) Ltd., 2001, pp. 90-123, 127, 215-322.
- 10) W.L FAISLER An introduction to modern electronics, john willey and sons Inc New York. 1991. pp 323,327.