

DESIGN AND CONSTRUCTION OF AN AUTOMATIC CAR DEMOBILIZER WITH HIJACK ALARM SYSTEM

By

**AWODELE S. OLUFIKAYO
99/8105EE**

**A PROJECT
SUBMITTED IN PARTIAL FULFILMENT OF THE
REQUIREMENTS FOR THE AWARD OF BACHELOR OF
ENGINEERING (B. Eng) DEGREE IN ELECTRICAL AND
COMPUTER ENGINEERING**

TO THE

**DEPARTMENT OF ELECTRICAL AND COMPUTER
ENGINEERING**

FEDERAL UNIVERSITY OF TECHNOLOGY MINNA.

NOVEMBER, 2005

TABLE OF CONTENTS

CERTIFICATION.....	I
DECLARATION.....	II
ACKNOWLEDGEMENT.....	III
DEDICATION.....	IV
ABSTRACT.....	V
CHAPTER ONE	
1.0 INTRODUCTION.....	1
1.1 MOTIVATION.....	3
CHAPTER TWO	
2.1 LITERATURE REVIEW.....	4
CHAPTER THREE	
3.0 DESIGN ANALYSIS AND PRINCIPLES OF OPERATION.....	6
3.1 MODE OF OPERATION.....	6
3.2 POWER CONTROL UNIT.....	8
3.3 SIGNAL GENERATION.....	9
3.4 TIMING CIRCUIT.....	11
3.5 CAR INTERRUPTION STAGE.....	13
3.6 ALARM UNIT	14
CHAPTER 4	
4.0 CONSTRUCTION, TESTING, AND PACKAGING	19
4.1 CONSTRUCTION.....	19
4.2 TESTING	19

4.3 ASSEMBLING OF COMPONENT.....21

4.4 CASING22

4.5 PROTECTION AND CONTROL.....22

4.6 TROUBLESHOOTING AND MAINTENANCE23

CHAPTER FIVE

**5.0 DISCUSSION OF RESULTS, CONCLUSION AND
RECOMMENDATION.....24**

5.1 DISCUSSION OF RESULTS.....24

5.2 CONCLUSION.....24

5.3 RECOMMENDATION25

REFERENCE.....26

CERTIFICATION

This is to certify that this project was carried out by Awodele S. Olufikayo of the Department of Electrical/Computer Engineering of the School of Engineering and Engineering Technology of the Federal University of Technology Minna, under the supervision of

Mr. Abraham Usman for the award of Bachelor of Engineering (B.Eng).

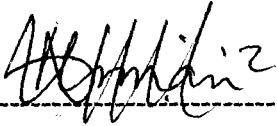

Mr. A.U Usman

5TH DEC, 2005

Date



Engr. M.D Abdullahi

16/02/06

Date

External Supervisor

Date

DECLARATION

I hereby declare that this project is written by me Awodele S. Olufikayo and that the contents are the result of my own design and calculation. All information obtained from published and unpublished works of others have been well acknowledged by means of reference.

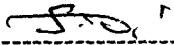

Awodele S. Olufikayo

99/8105EE



Date

DEDICATION

This project is dedicated to Almighty God for sparing my life to see the end of the program and also to my parents Mr. Samuel Awodele (of blessed memory) and Mrs. Comfort Awodele.

ACKNOWLEDGEMENT

It is said “gratitude is a memory of heart” I am therefore grateful to the Almighty God for the successful completion of my course in Electrical/Computer Engineering. From the depth of my heart I will like to express my sincere gratitude to my parents

Mr. Samuel Awodele (of blessed memory) and Mrs. Comfort Awodele, for their moral and financial support throughout my stay in the university. I also wish to express my deep appreciation and gratitude to my brothers and sister Oluwole Awodele, Oludele Awodele , Olufunsho Awodele, Abiodun Awodele and Iyabo Awodele for giving me the love and support throughout my academic career.

I am greatly indebted to my able wonderful and supportive supervisor Mr. Abraham Usman who through his advice gave this project a meaningful direction. My thanks also goes to the HOD and lecturers for their contributions towards the laying of fundamental knowledge which is put together to achieve the aim of this work piece.

Finally, special thanks also goes to my friends and colleagues, Thomson, Peace, Sunday, Dapo, Stanley, Abdul Razaq and others for their support and encouragement given me during the course of my study.

ABSTRACT

The automatic car demobiliser with hijack alarm system is designed with pulse generator to be delayed for about five minutes after the car is hijacked. At the end of the time frame it triggers a silicon controlled rectifier (SCR) to activate a relay. The relay in turn demobilizes any automobile system it is connected to and the alarm is also triggered and continues until the owner of the vehicle comes. The demobilizer is recommended for every car owner.

CHAPTER ONE

1.0 INTRODUCTION

Car theft and burgling is a common phenomenon these days owing to the high cost of cars and spare parts. At most times the owners of such stolen vehicles cannot afford to replace them. Thus the use of electronics car antitheft has become a necessity due to this ugly trend. These days most car security systems come with the car from manufacturer, and at times are brought off the shelf and installed by the car users.

As houses, business and lives can be secured, so should properties such as cars be secured. The security of the car should not stop having document of insurance, other means of preventing and protecting car theft should be employed.

As an electrical engineer this was a motivation in using the knowledge of electronics to combat this problem. A better solution toward these problems is to use an automatic switch to demobilize a car. The advantage of the automatic switch is the time delay that is added should in case the car is snatched at gunpoint, once the switch is pressed the intruder can only have the car running for a preset or predetermined minutes before the security system is activated thus demobilizing the car. The inclusion of an alarm system is to alert the car owner once the security system is activated.

This project tile "Design and Construction of an automatic car demobiliser with hijack alarm system" was built around a pulse generator (IC Timer). The pulse generator is delay for five minutes which is the time it will take for the IC timer to go from HIGH state to LOW state. At the end of time frame, it triggers a silicon control rectifier (SCR) which acts as a switch, which in turn activates the relay that has been connected in to the car system to interrupt the mobility of the car and to activate the alarm system to alert the car owner.

f

One of the advantage of this security system is that it guarantees the security of the car whether in motion or not, provided the switch is connected in such a way that the intruder will activate it unknowingly e.g. by turning the ignition of the car and disconnecting the ignition coil of the car. This in turn activates the alarm installed with the system to alert the owner of the presence of an intruder.

This project as a whole is designed to meet certain aims and objectives which include:

- i) To generate pulse using the IC timer.
- ii) To provide a time delay.
- iii) To interrupt the car system once it is activated.
- iv) To trigger on the alarm to alert the owner.

1.1 MOTIVATION

Most people suffer from incidents that are clearly available, although not known to some. This challenges force to take up a better solution to solving this singular problem that has put many car owners now to become pedestrians.

Although security system for cars has for a long time been in existence, this one I'm sure will help to clear the loopholes left behind for the armed robbers from initial method.

Therefore the design and construction of this project work is in such a way that it will be of interest to any one that needs and values his/her property.

Chapter one of this project reports gives introduction to general principle and importance of the project, its advantages, objectives and challenges of the project.

Chapter two explained the literature review .

Chapter three of this project deals with design analysis and principles of operation, include the power control unit, the signal generation, time delay, car interruption and alarm system.

Chapter four is the construction, testing and packaging of the project.

Chapter five contains the discussion of results, conclusion and recommendation.

CHAPTER TWO

2.0 LITERATURE REVIEW

Car security system wouldn't have been thought necessary. At a time cars were non-existent and when they were eventually made there was no much need for security system, since car stealing was not a problem. Events of 1896 and beyond changed all that. Cars became natural targets for thieves being valuable, reasonably easy to resell and processing a built-in gate way system. Some studies claim that a car gets broken into every twenty seconds in the United States ^[1]. Nigeria and infact Minna and its environs have not been left out of the cases of car theft. Since all these insecurity act as stated that is stealing and hijack of automobiles. both the manufacturer and the user are faced with the challenges of making it secured against thieves and unauthorized persons. The first measure used by the manufactures is the use of ignition key and car door lock. Since only the car user or authorized person have access to the key, it makes it secures against any intruder. As time has provided this method does not ensure adequate security of the car in the car since wire can bridge to start the car in the absence of key and most car lock can be picked by the intruder.

Various methods have been used by car users which include disconnection of battery, chaining of the stirring wheel etc. All this methods as well as the previous ones does not ensure adequate security of the car. Men of the underworld have designed means of beating all security measures and make way with vehicle. Another disadvantage of this method is that it does not provide any security if the car is snatched at gun point.

Due to the advent of technologies today there are various manufacturers. These security systems make use of various principles and method. Although all these methods provide better security for the car, it dos not guarantee 100% security. Intruders in most cases were

able to discover limitations and short come of all these security gadgets and are still able to make away with cars.

When thyristor , integrated circuits and other electronics components were invented , it was considered a revolution small, fast , reliable and effective, it quickly replaced the vacuum tube^[3]. Desirable electrical constructions become realizable. Most designs that had to be constructed in enormous surfaces could have been done on surface as small as a breadboard. This invention, among other developments, also had a significant impact on construction of car security system. As technology improves better security system will be designed that will provide better security to life and property of car users.

CHAPTER THREE

3.0 DESIGN ANALYSIS AND PRINCIPLE OF OPERATION.

The automatic car demobiliser with car hijack alarm system consists of components such as resistors, capacitors, thyristor, relay switch, IC timer and loud speaker which converts the electrical signal or pulses to sound.

The components are arranged in such a way that the principle of operation can be grouped into different stages. The stages include:

- I. Power control unit
- I. Signal generation
- II. Time delay
- III. Car interruption
- IV. Alarm system

3.1 MODE OF OPERATION.

The system depends on the triggering ON of the switch. The circuit is directly powered from the car battery and earthing is achieved through the interior light circuitry which is designed to operate when the door is open or when the ignition key is turned once the system PUSH switch is ON.

The system has advantage, as the system can be used when the car is stationary or in motion.

When in motion the system can only be activated by pressing the push-switch hidden in the car should in case the car is snatched at gun point which in turn activates the system at a preset time.

In the case where the car is stationary, the door is opened or the ignition key is turned the system is automatically activated. Figure 3.1 shows how the connection looks like from the car battery to the security system.

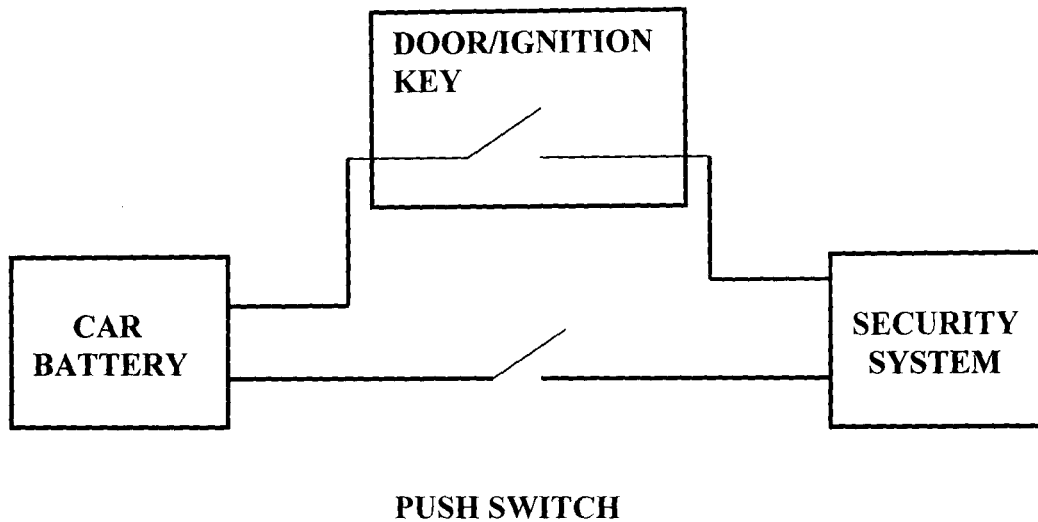

Figure 3.1

The system is built around the 555 IC timer connected in astable mode, that provides free running oscillation. The time delay mode is RC-controlled by two external components. Timing from microseconds to hours is possible.

The time delay is possible by the external components, R_a , R_b and C_t (as shown in the circuit). Immediately the switch is ON, 12 volts from the car battery drop across the IC timer and the source terminal of the thyristor. Thyristor is a gate controlled semiconductor that requires a gate voltage to be switched on.

The inclusion of the inverter is to make sure that the first pulse, from the timer that produced an High output at pin 3 is inverted to low at the output of the inverter. The thyristor gate

voltage remains zero. When the pulse signal is low at preset time, the output of the inverter becomes high and thus provides the gate voltage that switches ON the thyristor. Once the gate of the thyristor is triggered ON, it remains in the ON state even if the gate voltage is removed, unless the voltage is reset.

The voltage in turn activates the normally closed relay connected to the electronic fuel pipe and the ignition coil. At the same time activates the alarm system that alerts the car owner of the presence of an intruder.

In summary the arrangement of R_A , R_B , C_T in fig 3.3a, is timing determining components. C_1 which is 0.01uf is used to block false or unwanted triggering.

4069 is an inverter that inverts the output of 555 timer. If the input of the inverter is low the output will be high hence it triggers the silicon controlled rectifier to energize the relay. But if the input of the inverter is high the output of the same inverter will be low and it does not trigger the silicon controlled rectifier, therefore the relays will not be activated.

R_1 reduces the current that flows to the gate silicon control rectifiers

3.2 POWER CONTROL UNIT.

The system is supplied with a 12V dc from the car battery. The power is controlled by an electronic push switch that is located in a hidden place in the car.

A switch is ordinarily a device or component used to break a contact as used in this project. It breaks off the continuous passage of electric voltage [DC] from the supply (12V). In order to ensure the security of the car when stationary, the push switch is designed to be used as the main switch controls the positive supply of the system. The earthing is obtained from the circuitry in the car system which may be connected to the car door or ignition key. The design is made in such a way that if the main switch is closed and either the car door or

ignition key is turned it completes the contacts of the negative supply and thus the system is activated. The system can be deactivated if the main switch is open; this even if the car door is open or the ignition key is turned ON the positive supply to the security system is still cut-off.

3.3 SIGNAL GENERATION

The 555 timer is connected in astable mode and oscillates at a very high frequency for signal generation. Figure 3.3 below shows the timer used in an astable mode.

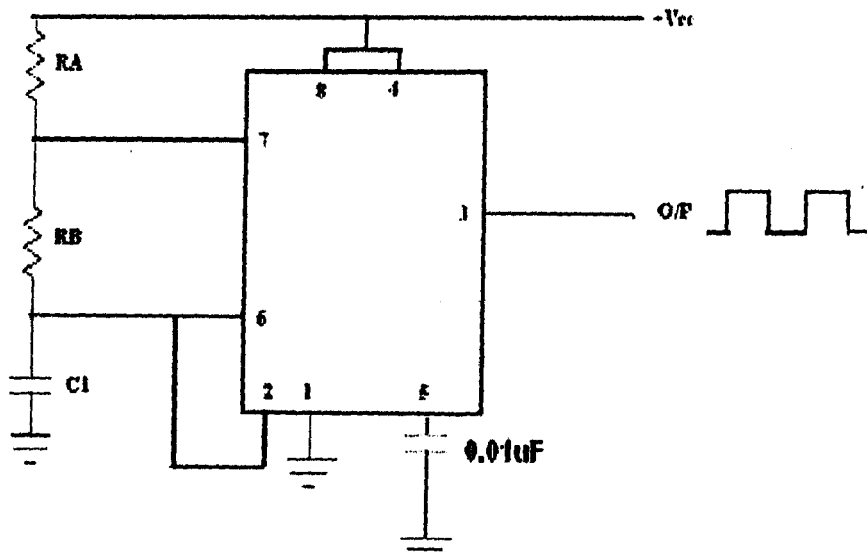

Figure 3.3a 555 Timer IC

The trigger (pin 2) input is connected to the threshold (pin 6) and the discharge output to the junction of the two external timing resistor R_A and R_B . An assumption that at time $t=0$ the latch has been set, causing V_{out} (voltage at pin 3) to switch to V (ON) and the discharge transistor is turned OFF. The timing capacitor C_1 charge towards V_{cc} at a time constant.

$$T_1 = (R_A + R_B) C_T$$

At time t_1 $V_{cap} = V_2$, causing the latch to reset. Hence V_{out} switch to V_2 and this discharges toward ground with a time constant:

$$T_2 = R_B C_T$$

But time t_2 , $V_{cap} = V_1$ and then the output of the comparator 1 causes latch to set the whole timing cycle repeat itself.

$$V_{cap}(t) = V_{cc} (1 - 2/3) e^{-t/T}$$

Where $T_1 = (R_1 + R_2) C_T$. The latch is reset at time T_1 when $V_{cap}(t) = V_2 = 2/3 V_{cc}$

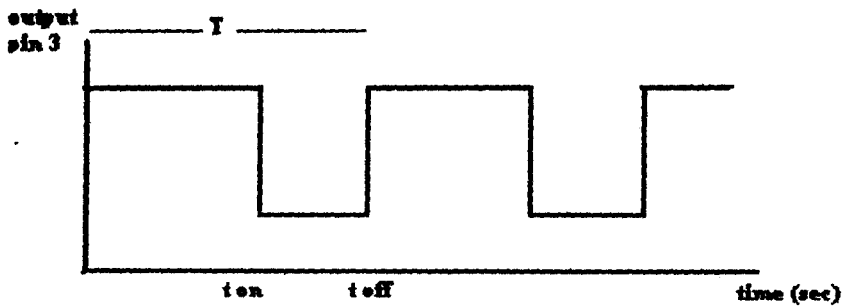

Figure 3.3b 555 Timer connected in astable mode

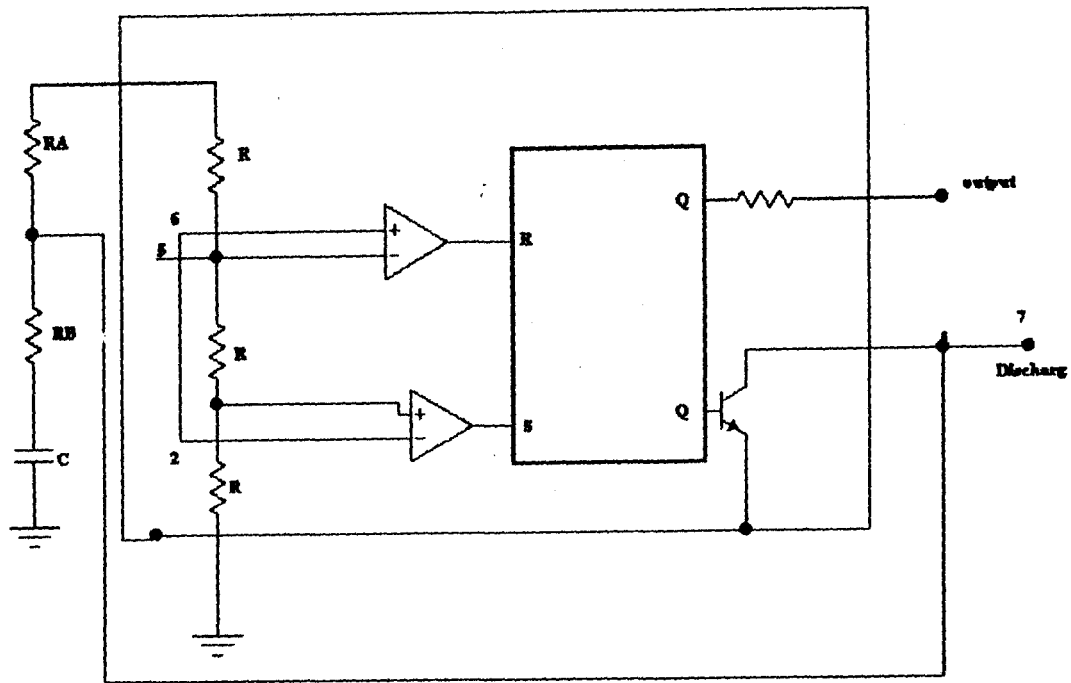

Figure 3.3c Internal connection of 555 Timer in Astable mode

3.4 TIMING CIRCUIT

At this stage of the system 5 minutes delay is required, hence only the first edge of the square wave is needed that is the t_{on} of the timer output (pin 3)

$$t_{on} = 5 \text{ min}$$

$$T_{on} = 0.69 (R_A + R_B) C_T$$

$$5 * 60 \text{ secs} = 0.69 (R_A + R_B) C_T$$

Selecting appropriate value of resistors R_A and R_B , C_T is calculated by substituting into the equation above. For t_{on} to be approximately equal to t_{off} , R_A is made several times greater than R_B .

Using $R_A = 470k$, $R_B = 450K$ and C_T is calculated below

$$T_{\text{high}} = 5 \text{ min} = 300 \text{ secs.}$$

$$C_T = T_{\text{ON}} / \{0.69 (R_A + R_B)\}$$

$$= 300 / \{0.69 (920K)\}$$

$$= 4720\mu\text{f, is the value of } C_T \text{ used}$$

$$T = T_{\text{on}} + T_{\text{off}}$$

$$T_{\text{on}} = 0.69 (R_A + R_B) C_T$$

$$T_{\text{off}} = 0.69 (R_B C_T)$$

$$T = \text{period}$$

$$= 0.69 (R_A + R_B) C_T + 0.69 R_B C_T$$

$$= 0.69 C_T (R_A + R_B) R_B$$

$$T = 0.69 * 470t - (1370k)$$

$$T = 444.291 \text{ secs}$$

$$T = 7.4 \text{min approx. } 7 \text{mins } 30 \text{ secs}$$

$$F = 1/T = 1 / 444.3$$

$$= 2.25 \text{MHz}$$

To achieve a time delay of 5 min, before the alarm circuit and the delay is triggered, an inverter was used at the output of the timer circuit to invert the output at pin 3.

Since the astable mode of the 555 timer is regenerative, meaning it does not need an input signal. The timer starts its time count as soon as the circuit is powered on. A thyristor is used at this stage for switching. At the output of the NAND gate (inverter) a resistor was used to overcome the faulty triggering that occurs when an inverter is used to trigger a very sensitive component like triac or thyristor as in the case of this project.

THYRISTOR AS A SWITCH.

A thyristor can be considered as a PNP transistor connected to an NPN transistor as shown below.

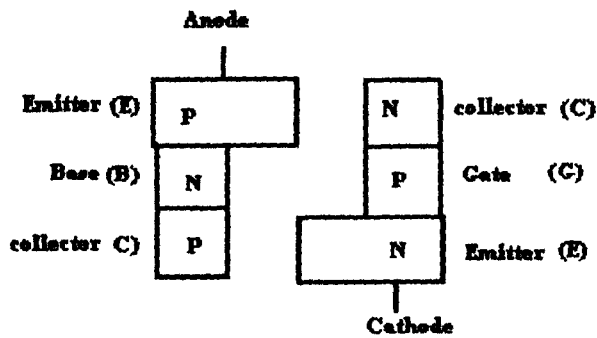

Figure 3.5 Thyristor

With the anode being positive with respect to the cathode, upon the application of a small positive trigger to the terminal, the npn transistor begin to conduct collector current in the npn transistor is equal to the current flowing towards the base of the pnp transistor.

Both transistors assume proper bias levels to ensure that the device conducts after the termination of trigger. As mention earlier the SCR turns off when the anode is reduced to a value less than the holding current.

3.5 CAR INTERRUPTION STAGE.

In the casa of this project, two relays are used. One of the relays which is a normally closed relay is to be connected to the ignition coil, while the other is to be connected to the electronic fuel pipe. Immediately the thyristor is switched ON, current supply to the relays open the contact of the normally closed and thus break the continuity of the system .The

reason why two relays are used is to ensure that when one fails the other will still be able to interrupt the normal operation of the car system.

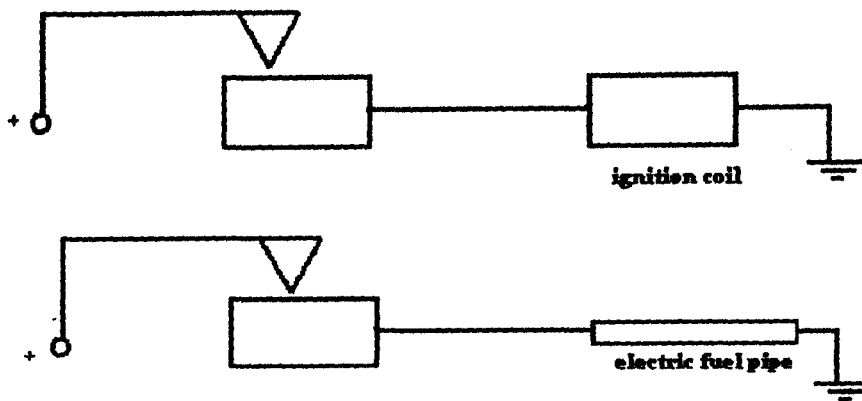

Figure 3.6 Relay

3.6 ALARM UNIT

The alarm circuit is triggered approximately 5 mins after the intrusion upon the car has occurred. This is achieved by the use of an inverter and thyristor as explained earlier. The output of the inverter triggers the thyristor that power the alarm circuit and the relay.

The alarm circuit is made up of two IC timer that the connection includes:

- i. Astable mode
- ii. Monostable mode

The timer generates oscillation producing voltages that in a regular fashion, the waveforms of the voltages are repeated in equal successive intervals of time. The instruments that produce repetitive waveforms that are square, triangular or saw tooth in shape are called relaxation oscillators. The term "relaxation" is used because during the generation of the waveforms there is a period of activity in which there is a sharp

transition from one state to another. This is then followed by a relatively quiescent one after which the whole cycle is repeated.

Oscillators can be constructed so as to operate at frequencies as low as one or two cycles an hour or as high as hundreds of megahertz. The selection of a suitable frequency or range of frequencies depends upon the function that the oscillator is required to perform.

The square waveform is rich in harmonic and so it is used in this project to generate the pulses used in the alarm circuit. The pulse is thus generated by 555 timer connected in astable mode.

The frequency is given as $f = 1 / T$

Where $T = 0.69 (R_A + 2R_B) C$

The second IC timer was connected in monostable mode as shown in fig 3.7. The monostable depends on the output of the astable IC. A coupling capacitor was used at the output of the astable to the input of the monostable and its function is to block d.c voltage to allow a.c voltage to pass to the monostable IC.

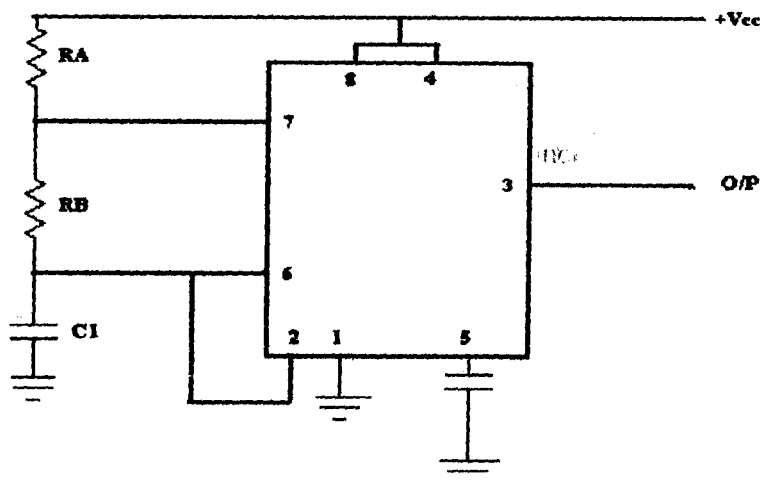
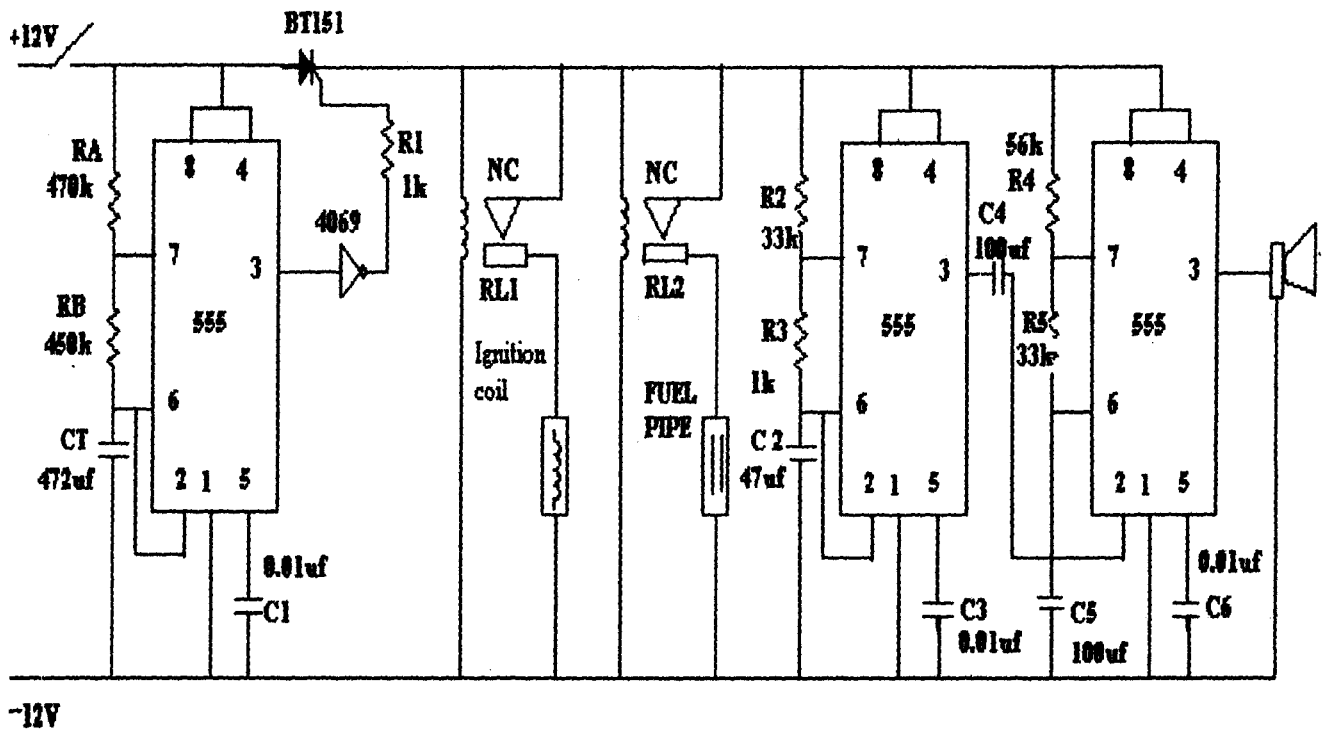
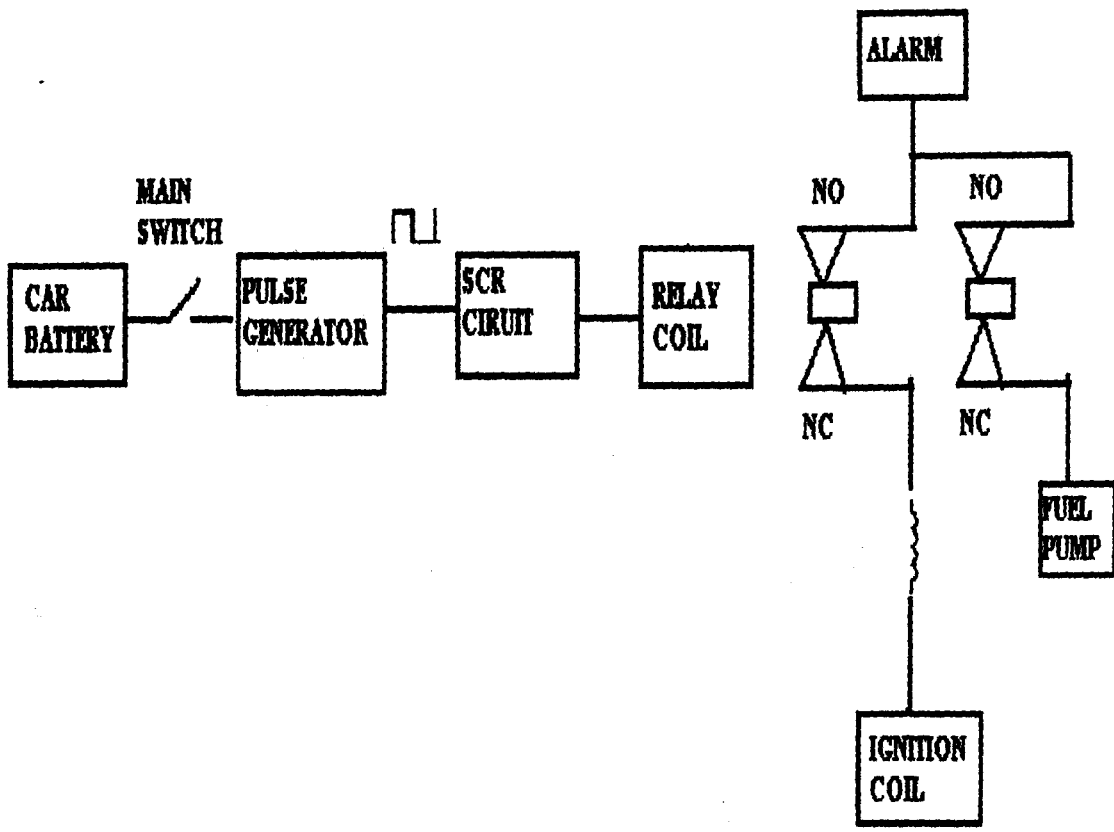

Fig 3.7 Astable mode

The monostable is a two tone generator with its output (pin 3) connected to a speaker that converts electrical energy to sound. Such sound produced could easily cut through commercial or industrial noise such as traffic, office or factory noise.



Circuit diagram of the automatic car demobilizer with hijack alarm system



BLOCK DIAGRAM FOR THE AUTOMATIC CAR DEMOBILIZER

CHAPTER FOUR

4.0 CONSTRUCTION, TESTING AND PACKAGING.

4.1 CONSTRUCTION

Construction is basically the mounting or assembling, connection, casing and the arrangement of components.

As mentioned in chapter three the system is made up of five different stages which include:

- i) Power control unit
- ii) Signal generation
- iii) Time delay
- iv) Car interruption
- v) Alarm system

In the process of construction of the project, the construction was carried out in stages on a breadboard and tested to have satisfactory output. The stages were being coupled with appropriate coupling devices which have been well designed to match the situation. After coupling all the stage sand satisfactory performance obtained, the layout diagram was drawn as it should appear on the printed board. The components were then transferred on to the Vero board, cuttings were made on the Vero board were continuity was not needed.

4.2 TESTING

Testing is the verification of the constructed items performance with regards to the expected output or results.

The principle of operation of each stage and the expected output has been treated in chapter three.

In this chapter the practical output waveforms of each stage and voltage levels at various points were monitored and measured respectively. Resistance values were just as stated in the data book or rated on the components

This was done in order to compare these results with the expected theoretical values. The results obtained were drawn from the waveforms and voltage respectively.

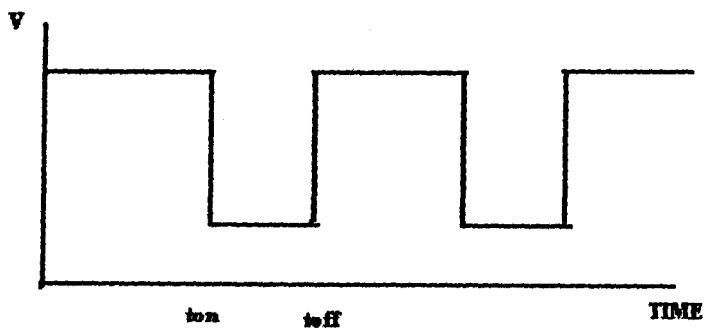

Figure 4.2(a) Output of timer circuit

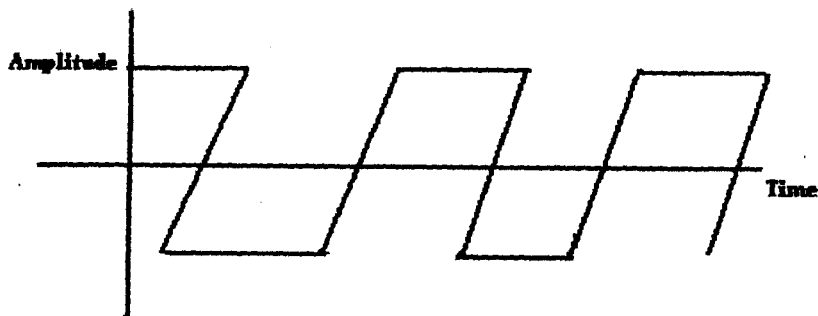

Figure 4.2 (b) Output waveform to speaker

4.3 ASSEMBLING OF COMPONENTS

Assembly work is sectionalized according to drawing operations. This enables easy identification of problems along the lines as work progresses. At first the power supply unit (i.e. 12v battery) is provided and tested okay follow by the timing circuit. Timing circuit is assembled as shown in the circuit diagram. It was equally tested to see if the calculated time delay is correct. A 12volts relay is mounted on the vero board and is well configured.

This arrangement acts as an external remote to the system. It is a prime mover of the entire components in the system. Lastly the astable multivibrator was also mounted to be fed by the relay contact.

The circuit at large was finally tested. However if problem is encountered at any stage, the problem is detected and rectified before the next stage is mounted. This is because it will ensure easy detection of the problem and hence reduce time wastage, possible damages to the components and condemnation of other components due to heating and wrong mounting when the work is done without testing at each stage.

Thus sectionalization helps for neatness of the jobs, safety of the components and economy of time.

4.4 CASING

The constructed hardware was enclosed in a wooden box. The various units of the hardware were firmly fitted to the base and sides of the box. A sketch giving the position of the mounted components and units is shown below.

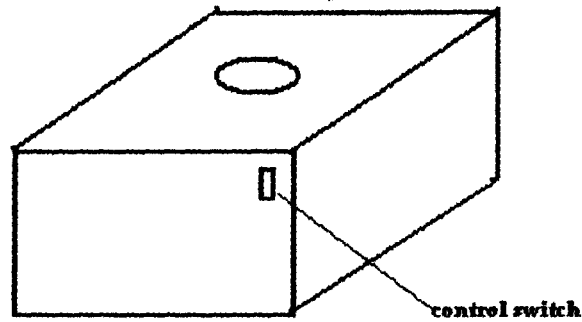

Figure 4.4 Casing

4.5 PROTECTION AND CONTROL.

With reference to the design and construction of his project there is every need for the system protection. The protection of this system due to its nature is basically centered on the packaging mode.

Due to the fact that the system is to be installed in a hidden place preferably in the dashboard par of the vehicle, there is therefore insufficient supply of air to the device. It his then protected from being overheated by the provision of a wooden enclosure covered with yellow formica capable of resisting heat dissipated by the component and external heat due to motor engine.

More for the device to function as desired, the control components, as designed in the system must meet its wiring requirement. The componenets for the control of this project are switches, the two switches (ON-OFF) type and the vehicle door switch which contributes to the automatic nature of the device. One of the ON-OFF switches is used as power switch and equally as a reset switch.

4.6 TROUBLESHOOTING AND MAINTAINANCE

This is a brief finding and rectification of faults in equipment. The following several methods and stages depending upon the nature of the equipment and faults.

In the maintenance of any electronic device troubleshooting can be said to be the most difficult once the faulty component has been traced the rest of the problem is as good as solved.

Fault diagnosis carried in state of the concerted circuit it is naturally split into several parts such as such as the power circuit the signal generation, time delay, car interruption and the alarm system as in this project.

Some faults causes and their rectifications are given below.

S/N	FAULT	CAUSES	REMEDIES
1	System not functioning	1. Check the door switch. 2. Check the connection	1. Remove it if it is faulty 2. Correct if desired.
2.	Demobilize before time delay expires	Check the supply voltage (more than 12v)	Correct by servicing the alternation (charger)
3.	Demobilized and failed to mobilize	. Disconnect, open the system and check the relays	Replace the relays

CHAPTER 5

5.0 DISCUSSION OF RESULTS, CONCLUSION AND RECOMMENDATION

5.1 DISCUSSION OF RESULTS

The automatic car demobilizer with hijack alarm system work on the principle of set execute and reset mode as observed from the hard ware test carried out. A common voltage with magnitude of about 12V is required throughout the circuit. Opening of the door of the car or when the ignition key is turned once the system push switch is ON trigger the relay and the alarm circuit and this result to the demobilizing of the system after 5 minutes.

5.2 CONCLUSION

After careful design and construction of the project it was tested and proved to be successful. Some problems were encountered during construction which include the non availability of exact design values in the market and lack of Integrate Circuit (IC) tester to Check the condition of the ICs bought.

In conclusion, the aim of designing the car demobiliser with hijack system that is cheaply affordable and able to prevent the hijacking of cars has been achieved as observed from the test carried out on the device.

5.2 RECOMMENDATION

This project has been logically designed to be able to rescue all possible approaches to car theft and to give maximum protection to the owner. It is therefore recommended for all car owners.

The scope of the work leaves much room for greater improvement mostly to time constraint and limited resources. The circuit could be further enhanced to cater for a lot of other needs in car security.

It is therefore suggested as a further improvement on this project to incorporate a sequential logic lock to further turn off and on the ignition switch.

Reference:

- [1]. Tom Harris; how car alarm works, how stuff works, Inc. [http://electronics, Howstuffworks.com/alarm](http://electronics,Howstuffworks.com/alarm)
- [2]. Charles A. Schuler; 'Electronics principle and applications' (1990)
Fifth Edition, Glencoe/McGraw-Hill publisher
- [3]. History of integrated circuit, e-museum, [http:// www.google.com](http://www.google.com)
- [4]. B.L Theraja & AK Theraja ' A textbook on Electrical Technology'
- [5]. RALP J. SMITH, Second Edition 'Electronic Circuit Devices' (1968)
(John Wiley and sons Canada)
- [6]. Rutkowski G.B (1988); Solid State Electronics, Macmillan publishing company; New York
- [7]. W.A Dennis, Electronic Components and Systems, (1982) Butterworth and co (publishers) ltd