

DESIGN AND CONSTRUCTION OF 2KVA INVERTER

BY

ISAAC PATRICK

MATRICULATION NUMBER:

2006/24376EE

**A FINAL YEAR PROJECT SUBMITTED TO THE DEPARTMENT OF ELECTRICAL
AND COMPUTER ENGINEERING, SCHOOL OF ENGINEERING AND
ENGINEERING TECHNOLOGY, FEDERAL UNIVERSITY OF TECHNOLOGY,
MINNA, IN PARTIAL FULFILMENT OF THE REQUIREMENTS OF THE AWARD
OF THE BACHELOR OF ENGINEERING (B. ENG.) DEGREE IN ELECTRICAL
AND COMPUTER ENGINEERING**

November, 2010

DEDICATION

This project work is solely dedicated to Almighty God the giver of wisdom to wise and knowledge to the discerning or understanding for his mercy, guidance, provision and protection..

DECLARATION

I, ISAAC PATRICK, declare that this work was done by me and has never presented elsewhere for the award of degree. I also here by relinquish the copyright to Federal University of Technology, Minna.

ISAAC PATRICK

MR. TOLA OMOKHAFE

(Name of Student)

(Name of Supervisor)

Isaac Patrick 9/11/2010

(Signature and date)

Mr. Tola Omokhafa 9/11/2010

(Signature and date)

ENGR. A.G. RAJI

Supr Dr. G. I. Ighalo

(Name of H.O.D.)

(Name of External Examiner)

Ag. (Jan. 11, 2011)

(Signature and date)

Supr Dr. G. I. Ighalo 1/12/10

(Signature and date)

ACKNOWLEDGEMENT

My Sincere and Profound gratitude goes to God (my Maker, my Helper and my Shield) for the understanding, wisdom, knowledge and favour that I enjoyed during the period of this project. I am also appreciating the effort of my parents, my brothers for all their supports in finance, through advices, prayers and encouragements. My profound gratitude goes to my supervisor, Mr TOLA OMOKHAFE and my laboratory technician, Mr AJIBUWA for theirs assistance during the practical aspect of project work. my apperiation also goes to my H.O.D for the lecture delivered on power electronics which was the basis of my project work. and the entire lectura of electrical and computer engineering department my the Almighty God bless you in return.

TABLE OF CONTENT

Title page.....	i
Dedication.....	ii
Declaration.....	iii
Acknowledgement.....	iv
Abstract.....	vs
CHAPTER ONE	1
1.0 INTRODUCTION.....	1
1.1 AIMS AND OBJECTIVE	2
1.2 SIGNIFICANCE OF STUDY.....	2
1.3 SCOPE OF THE STUDY.....	3
1.4 METHOD OF STUDY.....	3
CHAPTER TWO	5
2.0 LITERATURE REVIEW	5
2.1 UNINTERRUPTABLE SYSTEM STRUCTURE	7
2.2 THE AC-DC-AC INVERTER CIRCUIT.....	7
2.3 THE IMPORTANCE OF INVERSION	7
2.4 APPLICATION OF INVERTER.....	8
CHAPTER THREE	9
3.0 DESIGN STRATEGY AND PRINCIPLE OF OPERATION	9
3.1 THE INPUT TRANSFORMER	9
3.2 THE FULL WAVE BRIDGE RECTIFIER	13
3.3 WORKING PRINCIPLE	14
3.4 CIRCUIT CALCULATION	15
3.5 THE OSCILLATOR/DRIVE STAGE	17
3.6 THERE ARE BASICALLY TWO CLASSES OF OSCILLATORS NAMELY	18
3.7 METAL-OXIDE-SEMICONDUCTOR FIELD EFFECT TRANSISTORS (MOSFETs).....	19

3.8	CALCULATION OF INPUT POWER (pin)	20
3.9	CONSTRUCTIONAL DETAILS	22
CHAPTER FOUR		25
TEST, RESULT AND DISCUSSION.....		25
4.1	CIRCUIT CONSTRUCTION	25
4.1.1	VERO BOARD	25
4.1.2	TRANSFORMER CONSTRUCTION AND TESTING.....	25
4.1.3	TESTINGTESTS AND RESULTS	26
4.1.4	TESTING OF OSCILLATOR UNIT	27
4.2	TESTING OF SWITCHING UNIT	28
4.3	PRECAUTIONS OBSERVED	28
4.4	RELIABILITY.....	29
4.5	THE RELIABILITY OF COMPONENTS USED.....	29
CHAPTER FIVE		31
CONCLUSIONS.....		32
5.1	CONCLUSION.....	32
5.2	RECOMMENDATION	32
REFERENCE.....		33
APPENDIX.....		34

Fig 1 relationship between inverter and/standby systems	2
Fig 2 Block diagram of 2kVA inverter	4
Fig 3.0 Shell type transformer	12
Fig 4.0 Driver circuit unit	18
Fig 5.0 complete circuit diagram	24
Fig. 6 Temporary work of Driver circuit	30
Fig. 7 2kVA Inverter Device	31

Table 4.1 Tests carried out and results obtained..... 26

ABSTRACT

This project, 2KVA inverter power supply is one of the applications of power electronic semi-conductor device system. The maximum power requirement is met by the use of power mosfets (metal oxide semi-conductor field effect transistor) in particular IRF3205 is used for this project because of its versatility of power rating of 200watt and amps rating of 110A. More also maximum power requirement is met with use of rated transformer of specified input and output voltage as well as frequency in the cause of this project, finally this project was carefully carried out, designed and constructed to the given specification where by the output can be compared with exiting ones in the market and economical is more cheaper.

CHAPTER ONE

1.0 INTRODUCTION

Utility electric power supply in Nigeria, have evolved to supply bulk electric energy to domestic, commercial and industrial customers. Statistics have shown that power failures are rare in some countries, but in country like ours, it is a frequent occurrence. Power outages are most troublesome utility many companies are faced with problems. These result mainly from faults. Such outages generally take from some few minutes to sometimes, period of hours or even days. These always create significant negative effect on the productivity of an industry or company. For instance, a data company can suffer a great loss of data may take hours or days to rebuild. In the area of transportation where the use of Electric trains, tramps, lifts etc power outage can be dangerous. In medical area, this could be life threatening these and several other factors call for the use of a stand-by power unit to safeguard the losses.

An inverter is one the solution to power outages .it is basically an application of an AC/DC'DC/AC converter. It is a power supply system connected between the user equipment with or without outages. Apart from the above, the supply is also free from frequency variations, spikes and transients. Inverter power supply system fall into the family of equipment termed Emergency/standby system. It development can be traced back to the beginning of computer age in the 1950's.

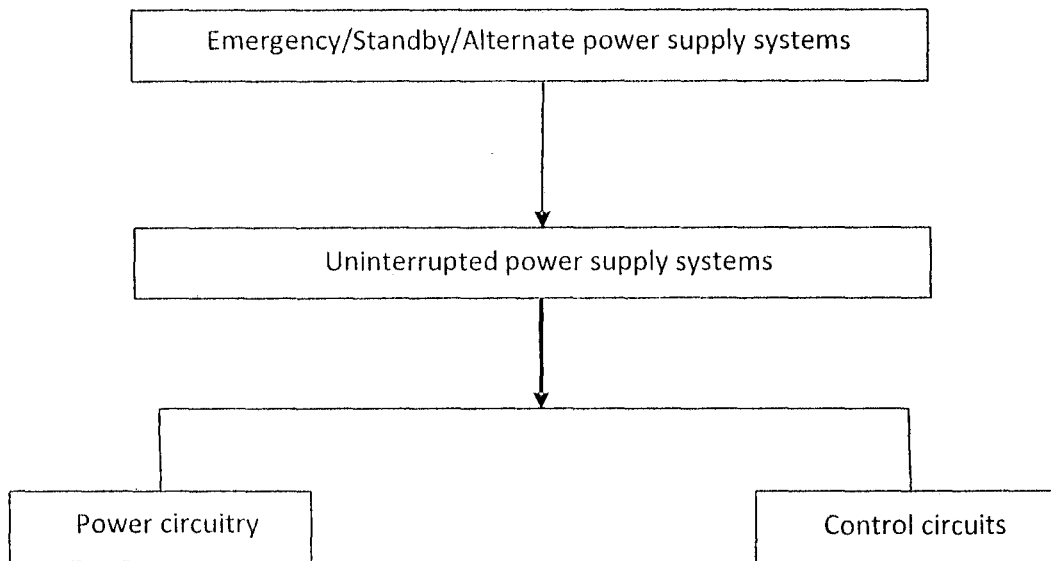

Fig 1.1 relationship between inverter and/standby systems

1.1 AIMS AND OBJECTIVE

This project is aimed at designing and constructing a 2KVA capacity inverter with automatic battery charging unit. This is to use a unique and simple means to achieve a better result taking into consideration the cost implementation.

1.2 SIGNIFICANCE OF STUDY

This project has a significance role to play in providing a lasting solution to losses incurred by industries in particular and the general society at large during possible power outages .though, there has been in existence various types of uninterrupted power system this application is unique in the sense that it combines the attribute of cold starting with

this application is unique in the sense that it combines the attribute of cold starting with the use HEXFET 111 MOSFET equipment with an integral body diode as the switching device thereby prolonging the lifespan of the system. It has a very high overload carrying capacity and latest design in the market which reduces the cost of entire circuitry.

1.3 SCOPE OF THE STUDY

the scope of these projects is limited to load up to 2KVA capacity .this means that it can carry load like an air conditioners (AC), refrigerator, television, VCD and some electrical appliances like standing fans, florescent lamb, incandescent lamb. Etc. Which are not more than 2KVA

1.4 METHOD OF STUDY

The method use in this study is by consulting textbooks, journals and data book various designer manual and consultant who are versatile in designing and constructing inverter or who are practically oriented in designing inverter.

In the construction IRF3205 (a special and recently modified power MOXFET) has been used as a controllable switching device because of its vast advantages over other electronic controllable switching device such as thyristors and transistors in addition to above advantages to the RF3205 body diode was also exploited.

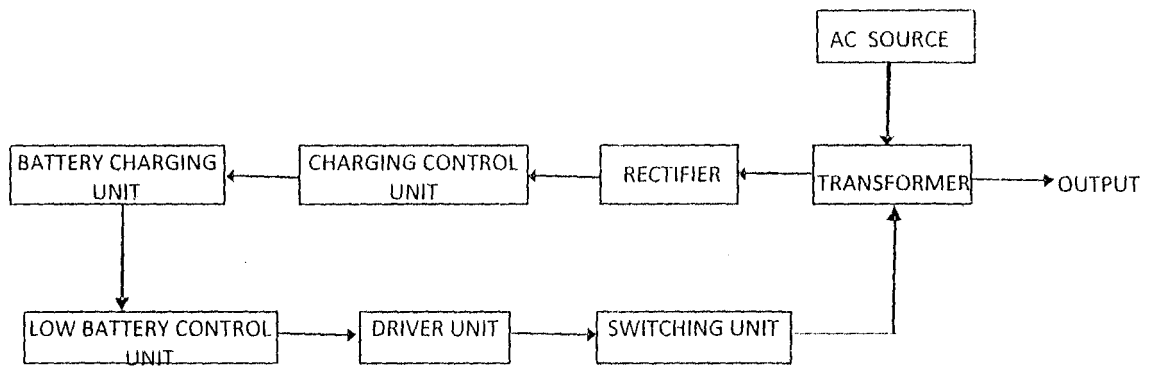

Fig 1.2 Block diagram of 2kVA inverter

CHAPTER TWO

2.0 LITERATURE REVIEW

As has been earlier on, utility power systems have evolved to supply bulk electric energy to customers for load such as lighting, heating, motors and other equipment that can tolerate momentary and long interruptions without damage and with incidental inconveniences. To supply such loads to meet their concept of reliability, utility companies employ feeder and capacitor switching, step feeder regulators, voltage reduction measures, and occasional complete interruption for critical maintenance work. However, a small fraction of the total consumer load consisting of emergency lighting, medical facilities, transportation, data processing and communication centre cannot tolerate utility quality power. As a result, a family of equipment termed emergency/standby systems has been developed to provide high quality power for that of the customer load, which requires it.

An Emergency power system is defined as an independent reserve source of electric energy, which upon the failure of the normal source, automatically provides reliable steady electric power within a specified time to critical devices and equipment whose failure to operate satisfactorily would jeopardize the health and safety of individuals or result in danger to property. A one line diagram for a system in which a solid (solid-state) uninterruptible power system provides the Emergency power is shown in fig.2. The module consists of a charger, a battery an inverter. The module is usually provide with a bypass circuit that transfer the Emergency load to the normal source either automatically if the power system or normally to isolate the power system for maintenance. The high-speed static switch closes first followed by the closing of the bypass circuit breaker and operating of the output CB. The inverter operates to supply the

emergency load continuously; it does operate in a standby mode .But this project operates in a standby mode (i.e. cold start).

The earliest inverter developed used the conventional thyristor because that was the only device available. This version requires extensive commutation networks using capacitors, and inductors to bring about turn-off, which is an advantage and the need to include inverse parallel connected feedback diode was not possible with thyristor.

The recent development of the transistor solved these problems enumerated with the thyristor version as they are now widely used and they have the added advantages of fast switching speed with less loss.

The most recent development in switching devices was the IRF 3205 Power MOSFET developed in 1979, which is by far, the fastest switching device yet. It is a voltage controlled device, which is suitable for this particular project. They offer many advantages over the thyristor models, in both linear and switching applications.

These advantages include very fast switching, absence of second breakdown, wide safe operating area and a very high, almost infinite dc gain. They require no snubbers and have low switching losses. They can be driven direct from buffer logic and the design can be used for different power rating unlike with other devices. The HEXFET 111 powers MOSFET have very high overload holding capacity (about 1200%) and have avalanche capacity, which is lacking in other devices.

2.1 UNINTERRUPTABLE SYSTEM STRUCTURE

The basic functional component of the system can be group into two main areas:

1. The power circuitry, which consists of in transformer, rectifier, battery bank, the inverter, the switching unit and the output transformer.
2. The control is made up of the following rectifier control, control relay, inverter control and the charge's control.

2.2 THE AC-DC-AC INVERTER CIRCUIT

The heart of uninterruptable power system is the inverter unit that accepts ac line power and delivers a transient free ac power to the critical load.

The inverter may receive its DC power from battery when the ac line power source is interrupted up to several minutes, but in most industrial applications, a rectifier feed it. The configuration is classified as DC converter because it is a two stage static frequency converter in which ac power at network frequency is rectified and then filtered in DC link before being inverted to ac at an adjustable frequency. Rectification and inversion are performed by discrete standard diodes and transistor a stable multivibrator circuit. Inverters can be classified as voltage source or current source. But only the will be discussed being the method adopted in this project.

2.3 THE IMPORTANCE OF INVERSION

The need for ac power source becomes imperative with an unreliable and unsteady utility power regime as ours. Therefore, comes in the inversion system.

Inversion simple means the method of changing a readily available dc source to an ac source of varying or steady frequency and voltage.

Inversion simple means the method of changing a readily available dc source to an ac source of varying or steady frequency and voltage.

2.4 APPLICATION OF INVERTER

- (a) Generation of 50/60Hz, fixed voltage ac from dc source
- (b) Speed control of three phase induction motors.
- (c) Induction heating
- (d) Standby power supply.

CHAPTER THREE

3.0 DESIGN STRATEGY AND PRINCIPLE OF OPERATION

The design of an inverter is such a task that demands utmost accuracy because of role it in replacing the main supply automatically with negligible or no deviation from the signal parameters.

3.1 THE INPUT TRANSFORMER

For this to be achieved, effectively, the calculations to be carried are as following

This transformer step up the ac input voltage needed for rectifier input .since the initial charging current of the battery is between 2A and 4A, the transformer is required to able to handle the current

Input/primary winding voltage, $V_P=240V$ (supply voltage) secondary current is =9A

(Chosen) we can now calculate for I_P using the formula below.

$$\frac{V_P}{V_S} = \frac{I_S}{I_P} \dots \dots \dots (1)$$

$$I_P = V_S \times \frac{I_S}{V_P}$$

$$I_P = 240v \times \frac{8.69}{220} = 9.4A$$

The shell type-transformer was preferred over the core type transformer in this project due to its economy of copper wire, high-voltage transformer or multi-winding design and higher flux concentration.

Working with the former mentioned parameter, the cross-sectional area, of the magnetic path, A_i , can be calculated thus

Lamination thickness=0.5mm

Number of laminations=63

Stock of laminations $0.5 \times 63 = 31.5\text{mm}$

Width of outer lamination limb, $a = 14.5\text{mm}$ (1/2 of 29)

Width of central limb, $b = 29\text{mm}$

Gross core area $= 31.5 \times 29\text{mm} = 913.5\text{mm}^2$

Net area of iron (stacking factor) of 0.9

$A = 0.9 \times 31.5\text{mm} \times 29\text{mm} = 822.15 \times 10^6$

Where $F = 50\text{Hz}$ (supply frequency)

B_{max} = maximum flux density = 1.35T (Assumed)

A_i = calculated

To find the primary and secondary number of turns N_1 and N_2 respectively.

Where 2.95 is gotten from

$N_p/V_s = 650/220 = 2.95$

$N_1 = 220 \times 2.95 = 649.5 + 5\%$

$= 650\text{turns}$

$$=650\text{turns}$$

While for secondary per winding is

$$70/24=2.95$$

For the secondary side N2

$$N2=24 \times 2.95=70.8+5\%$$

$$=70\text{turns}$$

The size of the copper wire for the primary and secondary windings of the transformer are calculated thus-value of conductor required in the primary, when current J is $4/\text{mm}^2$ and current is since

$$I_p=2000/12=166.67$$

While for

$$I_s=2000/240=8.33$$

Therefore

$$J=I/A$$

$$\text{Where } A = \frac{\pi d^2}{4}$$

$$d_p = \sqrt{4} \times \frac{166.67}{3.142 \times 4} = 7.28\text{mm}$$

$$d_s = \sqrt{4} \times \frac{8.695}{3.142 \times 4} = 2.76\text{mm}$$

From table 9D3 of fifteenth edition of the Regulation, the following size of wires for primary and secondary windings were chosen to be SWG 20 and SWG 18 respectively.

The diagram of the shell type transformer is shown below:

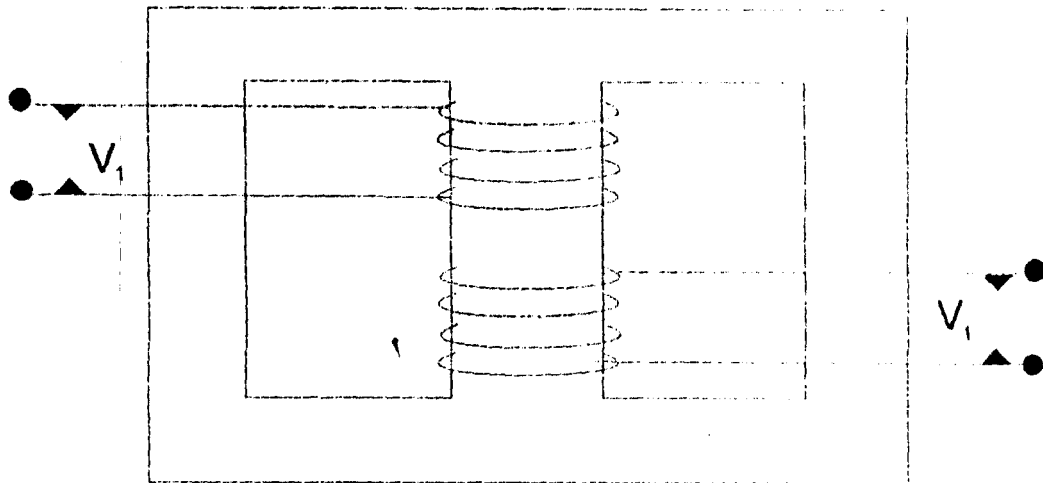

Fig 3.0 Shell type transformer

WORKING PRINCIPLE OF THE TRANSFORMER

A transformer is a static (or stationary) piece of apparatus by means of which electric power in circuit is transformed into electric power of the same frequency in another circuit. It can raise or lower the voltage in a circuit but with a corresponding decrease increase in current. The physical basis of a transformer is mutual induction between two circuit linked by a common magnetic flux. In its simplest form, it consist of two inductive coils which are electrically separated but magnetically linked through a path of low reluctance as shown in fig The two coils possess high mutual inductance. If one coil is connected to a source of alternating voltage, an alternating flux is set up in the laminated core, most of which is linked with the other coil in which it produces mutually induced emf (to faraday's laws of Electromagnetic induction $e=Mdi/dt$). If the second coil circuit is closed, a current flow in it and so electric energy is transferred (entirely

magnetically) from the first coil to the second coil. The first coil, in which electric energy is fed from the ac supply mains, is called primary winding and the other from which energy is drawn out, is called secondary winding. In brief, a transformer is a device that

1. Transfers electric power from one circuit to another
2. It does so without a change of frequency
3. It accomplishes this by electromagnetic induction and
4. Where the two electric circuits are in mutual inductive influence of each other.

3.2 THE FULL WAVE BRIDGE RECTIFIER

It is the most frequently used circuit for electronic D.C power supplies. It requires four diodes as the transformer used is not centre tapped and has a maximum voltage of V_{sm} (maximum value of transformer secondary voltage).

The full wave bridge rectifier is available in three distinct physical forms.

1. Four discrete diodes
2. One device inside a four terminal case
3. As part of an array of diodes in an ac

Four discrete power diodes were chosen for this project and all four were mounted on heat sinks.

The diagram is as shown below.

The diagram is as shown below.

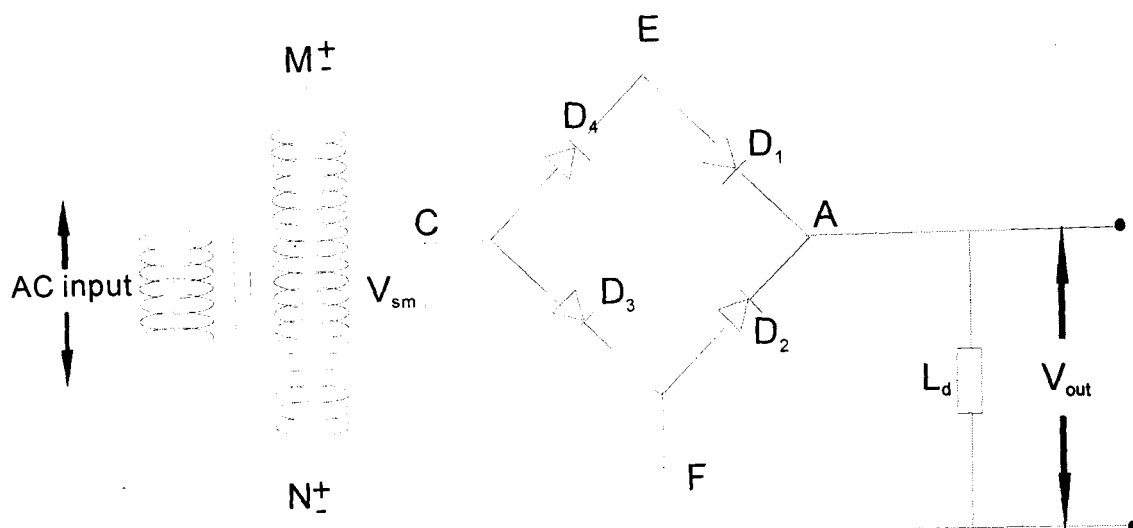

Each diode chosen can handle 8A in the forward direction as the initial charging current from flat battery is about 4A so as not to destroy the diode.

The PIV (peak inverse voltage) of each diode should be able to handle the entire voltage across the secondary of the transformer. The part number of the diodes used is IN3883R with PIV of 50V and forward current of 8A at temperature of 100.

3.3 WORKING PRINCIPLE

Using fig (3.2), during the positive input half-cycle, terminal P of the secondary is positive and Q is negative. Diode D1 and D3 become forward biased(ON) whereas D2 and D4 are reversed biased (OFF) Hence, current flows along PEABCFQ producing a drop across RL in the same direction AB during both half-cycle of the ac input supply. Consequently, point A of the bridge rectifier always acts as an anode and point C as cathode. The output voltage across RL is shown below; its frequency is twice that of supply frequency.

3.4 CIRCUIT CALCULATION

To find values R1 and R3 to maintain the LEDs longer life assumes the dc current (Idc) for each LEDs as 30mA

$$R = \frac{V_{dc} - 2}{I_{dc}} \dots \dots \dots (6)$$

Where 2 is the rated voltage drop across a LED

$$R = \frac{153 - 2}{30 \times 10^{-2}} = 443$$

D1 which was the phase control for SCR1, was chosen to be IN4001, based on the Vrms of secondary side of the transformer which is

$$V_{rms} = 17v$$

$$PVI = V_{rms} = 17V$$

Applying a safety factor of 2

Diode rating $17 \times 2 = 34v$ standardized to 50V (IN4001) which is a universal diode can handle up 1A

To select SCR1 cognizance is taken of initial high charging current it should handle which is about 4A therefore any thyristor capable of handling that current or higher, can be chosen and should be mounted on a heat sink.

SCR1 was chosen to be BTY79 which has the following characteristics:

$$\text{Frequency} = 50\text{Hz}$$

$$\text{Forward voltage} = 1000V$$

$$\text{Forward current} = 10A (85^{\circ}c)$$

For SCR1, since it is gated 'ON' or 'OFF' through R4-C1-RV1-ZD1 network which monitors the battery's terminal voltage, it is required to handle much current value. So any 50Hz, low -current SCR can do the job. C106D chosen and its parameter are:

Frequency: =50Hz

Voltage: 400v

Current: =2.2A

To find R4 we must first chosen the value of ZD1 to be used in getting ZD1 is chosen to be 6.8V

To get R4

Where V_i (min) =12V

V_Z : =6.8V

I_{MAX} =4A

It is necessary to point out at this point that $R4 < R4(max)$.

Since the current is not in milliamps, it is necessary to multiple the final value by 1000

$R4 (max) = 1.3k\Omega$

Since $R4 < R4(max)$, R4 was chosen to be 1.2k Ω . C1 is chosen to be between 50 μ F and 100 μ F and the voltage value should be twice the terminal voltage.

C1 was chosen to be 1000 μ F, 25V the value of R4 IS necessary to be high to prevent any accidental triggering of the SCR2 so R5 was elected to be 10K Ω .the value of RV1 was chosen to be 4.7K Ω

The component values for the charger control/regulatory unit are thus.

Resistors

R1, 2, 3-470 Ω

R4-1.2K Ω

Potentiometer: RV1-4.7K Ω

Capacitor: C1=1000 μ F, 25V (electrolytic)

Semiconductors

SCR1-BTY79

SCR2-C106D

D1-IN4001

ZDI-6.8V, 400MW

LED1, 2-TIL220.

3.4 THE OSCILLATOR/DRIVE STAGE

The SG3524 is a fixed frequency pulse with modulation voltage control circuit.

An oscillator may be defined in any of the following ways

1. It is a circuit which converts dc energy into ac energy at Avery high frequency

2. It is electronic sources of alternating current (ac) or voltage having sine, square or saw tooth or pulse shapes.
3. It is a circuit that generates an ac output signal without requiring any externally applied input signal.

3.6 THERE ARE BASICALLY TWO CLASSES OF OSCILLATORS NAMELY

1. Sinusoidal (or harmonic) oscillators-which produce an output having sine wave form
2. Non-sinusoidal (or relaxation) oscillators –they produce an output which has square, rectangular or saw tooth wave form or pulse shape

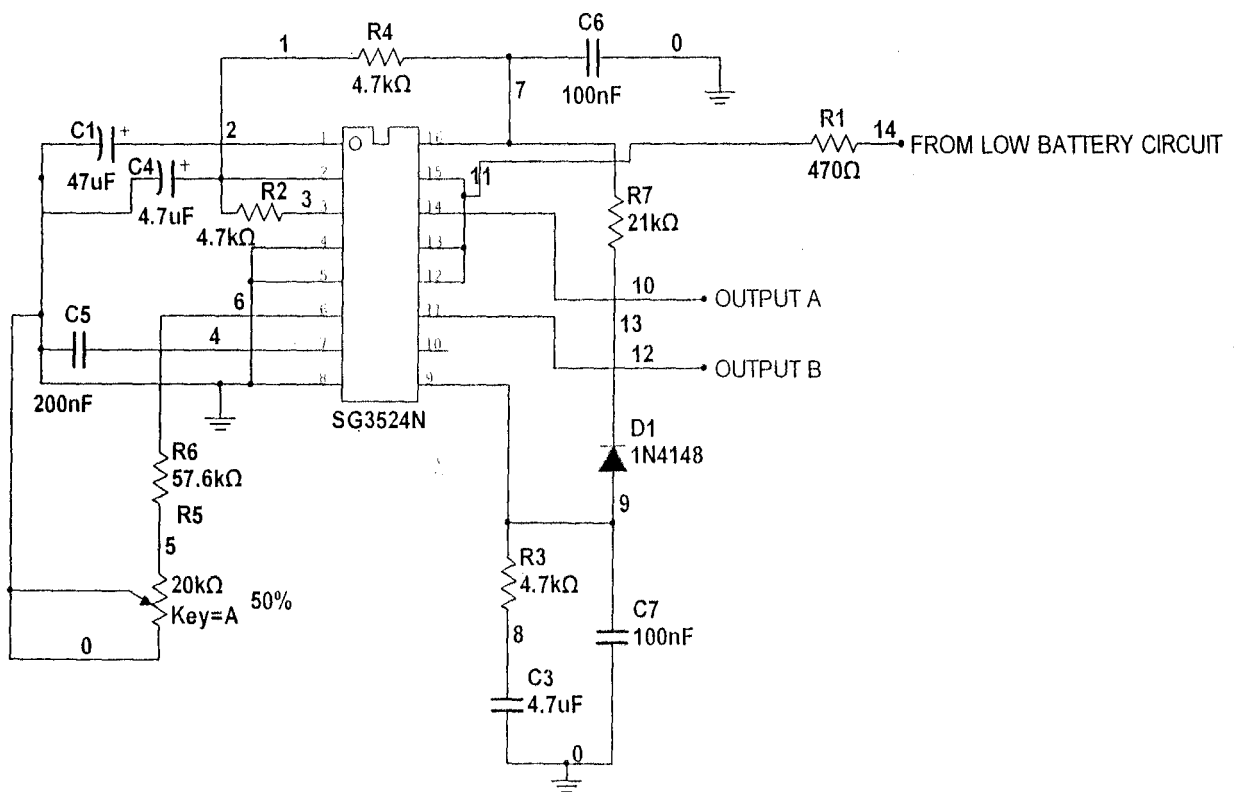

Fig 3.3.Driver circuit unit

The regulator operator at a frequency that is programmed by one timing resistor (RT) and one timing capacitor (CT) RT-established a constant charging current for CT, which is fed to the comparator providing linear control of the output pulse width by the error amplifier contain an un-board 5V regulator that serves as a reference, as well as powering the initial control, circuit is also useful in supply external support function.

SG3524 and to programmed by RT and CT according to the approximate formula

$$F = 1.18 / RTCT \text{ Where RT: in } 1K\Omega \text{ CT: is in } \mu F$$

Practical value of CT fall between 0.001 and 0.001 μF practical value of RT fall between 11.8 and 100K Ω . This result in a frequency range typical from 120HZ

3.6 METAL-OXIDE-SEMICONDUCTOR FIELD EFFECT TRANSISTORS (MOSFETs)

The circuit symbol of an n-channel MOSFET is show in Fig. 2-9a. It is a voltage-controlled device, is indicated by the i-v characteristics as shown in Fig. 2-9b. The device is fully on and approximates a closed switch which the gate source voltage is sufficiently large. The MOSFET Is off when the gate source voltage is below the threshold value, $V_{GS(th)}$. The idealized characteristics of the device operating as switch as shown in Fig. 2-9c.

MOSFETs require the continuous application of a gate-source voltage of appropriate magnitude in order to be in the on-state. No gate current flows except during the transitions from on to off or vice versa when the gate capacitance is being charged or discharged. The switching times are very short, being in the range of a few tens of nanoseconds to a few hundred nanoseconds depending on the device type.

The on-state resistance $r_{DS(on)}$ of the MOSFET between the drain and source increases rapidly with the device blocking voltage rating. On a per unit area _____ the on-state resistance as a function of blocking voltage rating BV_{DSS} can be expressed as

$$r_{DS(on)} = \frac{k}{BV_{DSS}^4} \quad (2-9)$$

Where k is a on state that depends on the device geometry. Because of this, only devices with small voltage ratings are available that have low on=state resistance and hence small conduction losses.

However, because of their fast switching speed, the switching, the switching losses can be small in accordance with Eq. 2-6. From a total power loss standpoint, 300 – 400V. MOSFETs compete with bipolar transistors only if the switching frequency is in excess of 30 – 100 kHz. However, no definite statement can be made about the crossover frequency because it depends on the operating voltages, with low voltages favoring the MOSFET.

MOSFETs are available in voltage ratings in excess of 1000V. But with small current ratings and with up to 100A at small voltage ratings. The maximum gate-source voltage is ± 20 , although MOSFETs that can be controlled by 5-V signals are becoming available.

MOSFETs are easily paralleled because their on-state resistance has a positive temperature coefficient. This causes the device conducting the higher current to heat up and this forces it to equitable share its current with other MOSFETs in parallel.

3.7 CALCULATION OF INPUT POWER (p_{in})

With specification of 2KVA expected rating of the design, some assumptions are made such as:

Specification =2KVA, $V_{out}=220-200$, $V_{dc}=12v$, $p_{in}=2000Va$

CALCULATION OF THE INPUT CURRENT (I_{in})

From the fundamentals it is well known that

$P=IV$, where p =power rating,

I =input current and

V =input voltage

Hence, $I_{in}=P_{in}/V_{in}$

Since V_{dc} to the inverter is 12v from the battery, and a direct current, there is no presence of phase angle, therefore $\cos\phi=1$. Hence, the above formula holds. It is inevitable that there must be some sort of voltage drops possible due to the internal resistance of the battery cells. This drop at its maximum can be taken to be 0.5v since the maximum gate to source voltage specification of MOSFET is (± 20).

Assuming a maximum V_{in} of 11.5 recall $V_{dc} > V_{in}$ from the above,

$$I_{in} = 2000/11.5 = 174A$$

Each of the MOSFET switches will handle half of this in current, which implies that

$$I=174/2=87A$$

In order not to overstress a single device and also due to the fact that high current is involved, each switching segment is made to have five MOSFETS in parallel to share the current given by

$$I_{sp}=87/5=17.4A$$

The voltage to be handle by switch is given by

$$V_{sw}=2 \times 12=24v$$

As a result of this, the switching device chosen to use is POWER MOSFET IRF3205 this is to the ease of paralleling the single gate driver required.

THE INVERTER/OUTPUT TRANSFORMER

This inverter/output transformer is a set up and centre tap transformer. This is because the 12Vdcv supply from the battery and outputs from the inverter section are fed to it through the speed power MOSFETS switches. It therefore, steps up the alternating input to about 240Vac for the load end.

It principle of operation is similar to the input transformer earlier discussed, with the exception that this one now steps up the voltage unlike in the former case which steps down the voltage.

3.7 CONSTRUCTIONAL DETAILS

Step-up transformer that step-up voltage from 12ac to 240 50Hz with a primary current of about 173A maximum primary current of 10A it is needed. it is a 12V centertap transformer.

$$\frac{E1}{E2} = \frac{N2}{N1} \dots \dots \dots (12)$$

Where k (the constant) is known as the transformer is called step down transformer assuming $E1=12v$

$$E2=240v$$

$$\frac{E1}{E2} = 20. \text{ Where } k=20 \text{ and shows that the transformer will function effectively.}$$

Since the power rating of the inverter has being given to be 2000KVA

The transformer lamination is still 0.5mm, the core is rectangular in shape, the limb is 29mm

Wide and the outer limb is 14.5mm

$$AP = I_p / \delta = 174 / 5 = 34.8 \text{ mm}$$

To find the diameter of the copper wire

$$A = \frac{\pi d^2}{4} \dots \dots \dots (13)$$

$$D_p = 6.65 \text{ mm.}$$

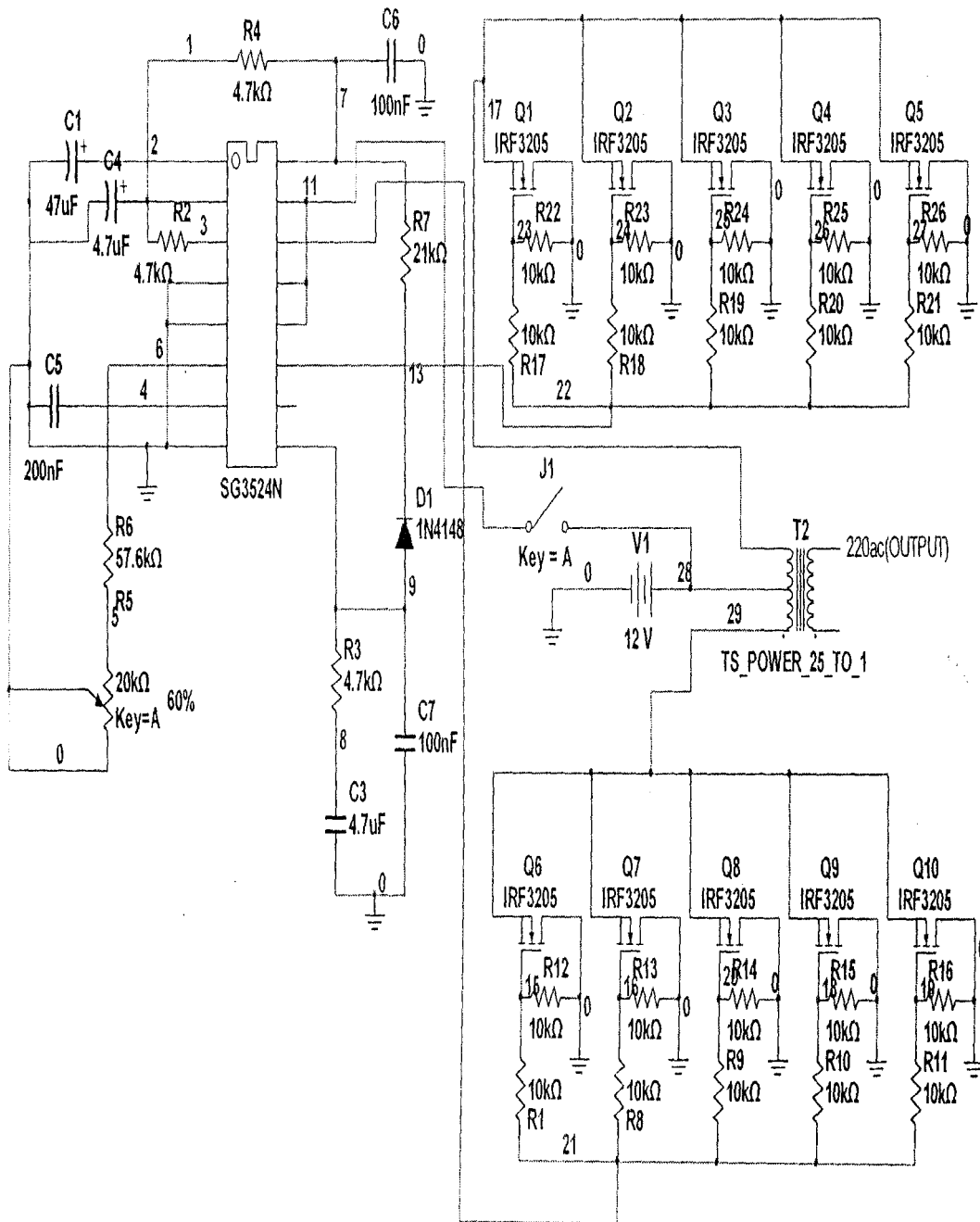

Fig 3.4 complete circuit diagram

CHAPTER FOUR

TEST, RESULT AND DISCUSSION

4.1 CIRCUIT CONSTRUCTION

The circuit construction started with the metric layout of components on paper, which was carefully cross-checked for flaw before being conveyed to the breadboard for initial testing. This was done in sequence order to avoid installation errors this with power supply components down to the output transformer, after satisfied with the output performance, the entire components were convey to the Vero board for permanent soldering.

4.1.1 VERO BOARD

The Vero board is the material use for permanent soldering of the tested components. Before being used, it was vividly purified from dust using emery cloth. The respective slots for each soldering were than marked out before placing the component in their respective slots. A 40watt soldering iron was used so as not to overheat the components during soldering, thereby ensuring that they not damaged by excess heat.

4.1.2 TRANSFORMER CONSTRUCTION AND TESTING

The transformer carry the two coils, is constructed from the tesolite. The lamination is then cut out in the shapes of 'E's and 'I's in order to absorb or disallow vibration and also make the work neater standard. These are inserted one after the other alternatively on each side of the former. Wooden mallet is then used to close to tap in the lamination properly to the entire air gap.

This is usually done after the primary and secondary winding on the former, moving in cyclic direction and the end; it will be separated from the beginning of the secondary winding with a transformer insulating paper. After this, the secondary winding was wound on top of the primary winding and all taping were brought out. When the lamination have been inserted properly, the whole coil of the transformer will be immersed in a container of varnish and later brought out to dry in sun for about three hours, covering the entire coil with impregnated paper to provide mechanical protection against damages followed by bolt and nuts were then used to hold the lamination firmly into place, before any test is carried out.

4.1.3 TESTING TESTS AND RESULTS

The following tests were carried out during and upon completion of the work, and the result tabulated below;

Table 4.1 Tests carried out and results obtained

TEST	RESULTS OBTAINED
1. 220V was applied across the secondary of the transformer of the inverter.	12.5V was measured across the primary.
2. A 12V battery was used to power the oscillator.	The voltage across the collector and ground was measured to be 3.7V.
3. A fully charged 12V battery was connected to the inverter.	220V was measured across the terminals of the secondary of the transformer.
4. The inverter was continually loaded to 1300W	The output voltage continually dropped as it was loaded to 220V, the laminations of the transformer and the MOSFET began heating gradually
5. The inverter was left on for a period of time without loading it.	The output voltage remained stable.
6. The secondary of the transformer of the inverter was connected to the AC mains.	The charging voltage measured across the terminals of the battery was dependent on the supply voltage.
7. The inverter was left on so the battery could completely discharge.	At 9V the inverter automatically switched off.
8. The automatic voltage regulator was tested for regulation.	The output voltage was a constant 220V.
9. The inverter and AVR combination was operated and loaded on the inverter mode.	The output voltage was a constant 220V.
10. While the inverter and AVR combination was on the inverter mode, the mains switch was turned on.	The inverter was immediately cut-off and the battery began charging without interruption of supply to the load

Testing like continuity test of all the coil sections of the transformer were performed, including insulation resistance test between the primary and secondary windings, between

the winding and the core using a multi-meter. The transformer was then powered by using NEPA source, the desired and calculated values was then obtain and losses were discovered to be very minimal and negligible.

4.1.4 TESTING OF OSCILLATOR UNIT

After the oscillator section have soldered, it was tested by feeding 12volt into it and digital multimeter was used to measured the ACV and DCV whereby oscillating pin of SG3524N,that is pin 11 and 14 are connected to the source of the MOSFETs.

4.2 TESTING OF SWITCHING UNIT

After mounting the ten MOSFETs on the heat sinks, they were then properly soldered using thick gauge wire for the drain and source as they intended to handle high current values. They are then linked to the oscillating unit and the secondary of the transformer is then connected to the gate of the MOSFETs and the output is then taken from the ends terminal of the primary side of the transformer, showing clearly that there no problem with design. The results obtained also imply that the design parameters were adhered to.

4.3 PRECAUTIONS OBSERVED

The following were the precautions taken in the cause of this project design and construction.

1. The power supply was always turned off when not in use.
2. The transformer was grounded
3. The casting was earthed
4. The off-target solder splashes were carefully removed to avoid short-circuit

5.Ensured that all components were connected in conformity with their polarity before testing and soldering

6.The power MOSFESTs were left in anti-static supping bags until required for testing or soldering

4.4 RELIABILITY

Reliability can be defined as the probability that a component, device or system will perform its prescribed duty without failure for a given time when operated correctly in a specified environment

Probability-: implies reliability cannot be prescribed with certainty, i.e. not deterministic

Operated correctly-: without misuse or abuse

Specified environmnet-: expected operating condition (temperature, humidity, dust, e.t.c)

4.5 THE RELIABILITY OF COMPONENTS USED

About 90% of the components used in this project design are electronic components, which are robust, rugged and can withstand stress and are noted for their long life.

Therefore, under normal condition, this device has a long life guarantee

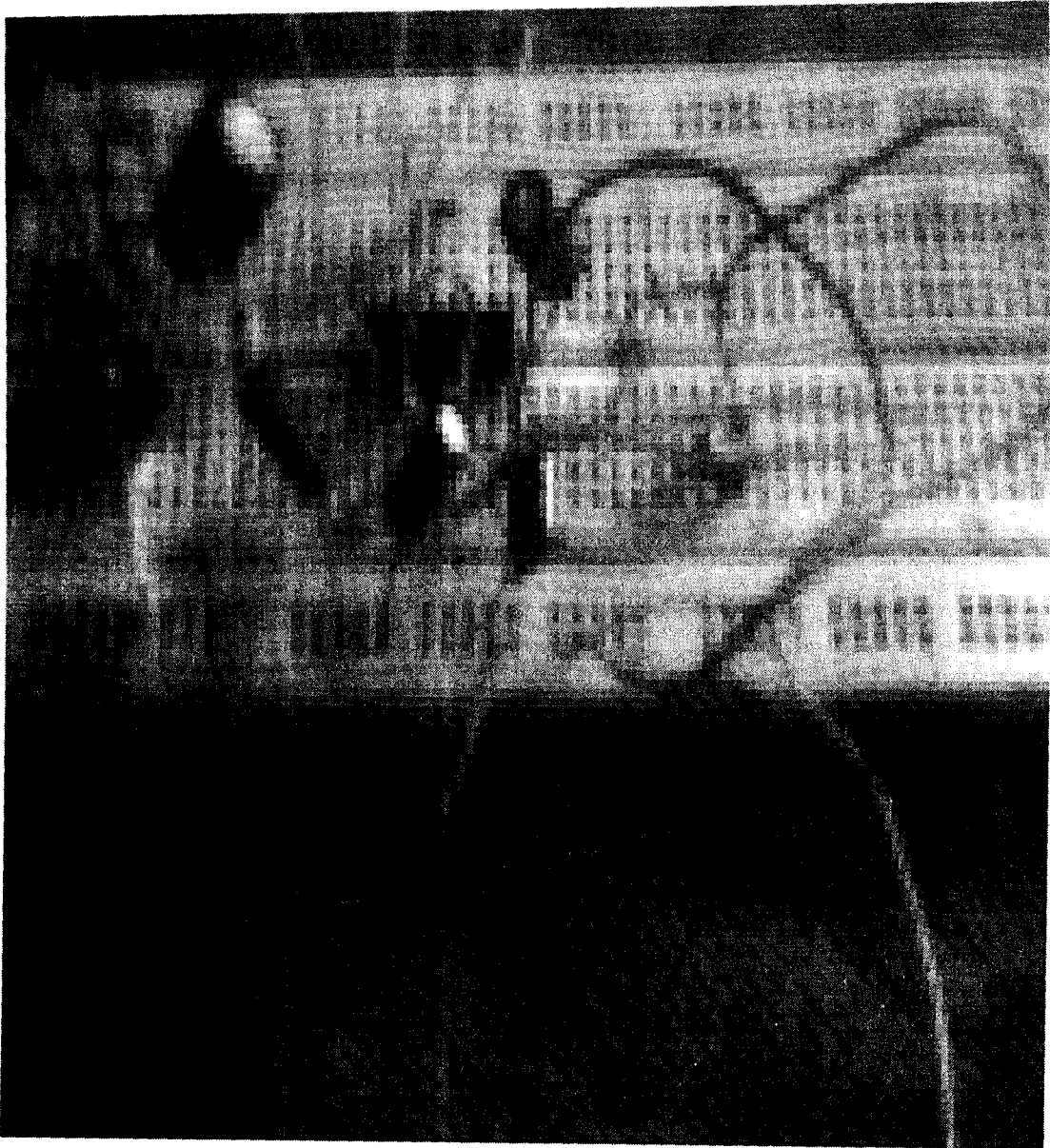

Fig. 4.1 Temporary work of Driver circuit



Fig. 4.2 2kVA Inverter Device

CHAPTER FIVE

CONCLUSIONS

In every endeavor of life, there must be problems. But they must important aspect of such endeavor is how those problems are solved.

Some of the problems I encountered as the course of these projects are as follow-:

The first was how to come out a with a fusible circuit design, because nobody as has work on 2kvA, both on net and electrical laboratory, it really big problem that almost made to have a change of project, but with the help of multism I finally conquer.

The second problem was the oscillating path because transistor could not oscillate, so with the help SG3524 I got Victoria over the oscillating unit or section.

The third problem was that the first MOSFETs were of low power rating, how I discovered it was by powering the circuit the multi-meter attempt picking but couldn't because the MOSFETs rating were of lower rating than then the transformer rating, so I was able to overcome that problem by replacing it with MOSFETs of rating equally to transformer rating.

5.1 CONCLUSION

The aim of this project is to design and construct a 2kVA inverter (DC-AC). This was satisfactorily achieved. This inverter is design with low battery circuit indicating when the battery is low

5.2 RECOMMENDATION

In both rural and urban area, consumer suffers untold hardships due to incessant output ages. There is also the need for government to support our tertiary institution financially and encourage the various departments of electrical and computer engineering to go into production such devices that will benefit the country in general.

I therefore recommend it for production by the Department of Electrical/computer Engineering of Federal University of Technology, Minna.

REFERENCE

- [1] <http://www.mitedu/open courseware. Com>
- [2] Engr, Raji: lecture notes and power electronics Department of Electrical Engineering Federal University of Technology Minna p,47—55
- [3] Dr. Tsado, Lecture note on power system protection Department of Electrical Engineering Federal University of Technology Minna
- [4] Theraja B.L and A.K.A
- [5] Engr,Dr ,Y. Adediran,lecture note on engineering reliability Department of Electrical Engineering Federal University of Technology Minna. P1
- [6] B. L Theraja and A. K Theraja, Electrical technology, S. Chand and company Ltd., New Delhi, 2007, pp.1115-2432.
- [7] Mohan N. et al, Power electronics converters applications and design, John Wiley and Sons Inc. 1989, pp.88-155.
- [8] Inverter FAQ (2006, November 08) www.powerstream.com/inFAQ.htm.
- [9] Owen, Edward L. "Origins of the Inverter" (1996, January/February).
- [10] Ed Gurdjian and Carol Maxwell "inverter history" (2000, March) www.rvtechstop.com/articles/Invhist.pdf
- [11] K. Thorborg, Power electronics, Prentice Hall International Ltd., United Kingdom, 1988, pp.246-453.
- [12] R. Sittig and P. Roggwiller, Semiconductor devices for power conditioning, Plenum Press, New York, 1982.

APPENDIX

Standard Wire Gauge	Diameter		Turns of wire		Cross-sectional area		Res. per length (for copper wire)		Mass per length		Current Capacity / A	
	in	mm	in ⁻¹	mm ⁻¹	<u>kcmil</u>	mm ²	Ω/km	Ω/kft	lb/ft	kg/m	750 kcmil / A	500kcmil/A
000000 (7/0)	0.500	12.7	2.00	0.0787	250	127	0.136	0.447	0.759	1.13	333	500
000000 (6/0)	0.464	11.8	2.16	0.0848	215	109	0.158	0.519	0.654	0.973	287	431
00000 (5/0)	0.432	11.0	2.31	0.0911	187	94.6	0.182	0.598	0.567	0.844	249	373
0000 (4/0)	0.400	10.2	2.50	0.0984	160	81.1	0.213	0.698	0.486	0.723	213	320

000 (3/0)	0.372	9.45	2.69	0.106	138	70.1	0.246	0.807	0.420	0.625	185	277
00 (2/0)	0.348	8.84	2.87	0.113	121	61.4	0.281	0.922	0.368	0.547	161	242
0 (1/0)	0.324	8.23	3.09	0.122	105	53.2	0.324	1.06	0.319	0.474	140	210
1	0.300	7.62	3.33	0.131	90.0	45.6	0.378	1.24	0.273	0.407	120	180
2	0.276	7.01	3.62	0.140	76.2	38.6	0.447	1.47	0.231	0.344	102	152
3	0.252	6.40	3.97	0.156	63.5	32.2	0.536	1.76	0.193	0.287	84.7	127
4	0.232	5.89	4.31	0.170	53.8	27.3	0.632	2.07	0.163	0.243	71.8	108
5	0.212	5.38	4.72	0.186	44.9	22.8	0.757	2.48	0.137	0.203	59.9	89.9
6	0.192	4.88	5.21	0.205	36.9	18.7	0.923	3.03	0.112	0.167	49.2	73.7
7	0.176	4.47	5.68	0.224	31.0	15.7	1.10	3.60	0.0941	0.140	41.3	62.0

8	0.160	4.06	6.25	0.246	25.6	13.0	1.33	4.36	0.0778	0.116	34.1	51.2
9	0.144	3.66	6.94	0.2773	20.7	10.5	1.64	5.38	0.0630	0.0937	27.6	41.5
10	0.128	3.25	7.81	0.308	16.4	8.30	2.08	6.81	0.0498	0.0741	21.8	32.8
11	0.116	2.95	8.62	0.3339	13.5	6.82	2.53	8.30	0.0409	0.0608	17.9	26.9
12	0.104	2.64	9.62	0.379	10.8	5.48	3.15	10.3	0.0329	0.0489	14.4	21.6
13	0.0920	2.34	10.9	0.428	8.46	4.29	4.02	13.2	0.0257	0.0383	11.3	16.9
14	0.0800	2.03	12.5	0.492	6.40	3.24	5.32	17.4	0.0194	0.0289	8.53	12.8
15	0.0720	1.83	13.9	0.547	5.18	2.63	6.56	21.5	0.0157	0.0234	6.91	10.4
16	0.0640	1.63	15.6	0.615	4.10	2.08	8.31	27.3	0.0124	0.0185	5.46	8.19
17	0.0560	1.42	17.9	0.703	3.14	1.59	10.9	35.6	0.00952	0.0142	4.18	6.27

18	0.0480	1.22	20.8	0.820	2.30	1.17	14.8	48.5	0.00700	0.0104	3.07	4.61
19	0.0400	1.02	25.0	0.984	1.60	0.811	21.3	69.8	0.00486	0.00723	2.13	3.20
20	0.0360	0.914	27.8	1.09	1.30	0.657	26.3	86.1	0.00394	0.00586	1.73	2.59
21	0.0320	0.813	31.3	1.23	1.02	0.519	33.2	109	0.00311	0.00463	1.37	2.05
22	0.0280	0.711	35.7	1.41	0.784	0.397	43.4	142	0.00238	0.00354	1.05	1.57
23	0.0240	0.610	41.7	1.64	0.576	0.292	59.1	194	0.00175	0.00260	0.768	1.15
24	0.0220	0.559	45.5	1.79	0.484	0.245	70.3	231	0.00147	0.00219	0.645	0.968
25	0.0200	0.508	50.0	1.97	0.400	0.203	85.1	279	0.00121	0.00181	0.533	0.800
26	0.0180	0.457	55.6	2.19	0.324	0.164	105	345	984 μ	0.00146	0.432	0.648
27	0.0164	0.417	61.0	2.40	0.269	0.136	127	415	.817 μ	0.00122	0.359	0.538

28	0.0148	0.376	67.6	2.66	0.219	0.111	155	510	665 μ	990 μ	0.292	0.438
29	0.0136	0.345	73.5	2.89	0.185	0.0937	184	604	562 μ	836 μ	0.247	0.370
30	0.0124	0.315	80.6	3.18	0.154	0.0779	221	726	467 μ	695 μ	0.205	0.308
31	0.0116	0.295	86.2	3.39	0.135	0.0682	253	830	409 μ	608 μ	0.179	0.269
32	0.0108	0.274	92.6	3.65	0.117	0.0591	292	957	354 μ	527 μ	0.156	0.233
33	0.0100	0.254	100	3.94	0.100	0.0507	340	1120	304 μ	452 μ	0.133	0.200
34	0.00920	0.234	109	4.28	0.0846	0.0429	402	1320	257 μ	383 μ	0.113	0.169
35	0.00840	0.213	119	4.69	0.0706	0.0358	482	1580	214 μ	319 μ	0.094 1	0.141
36	0.00760	0.193	132	5.18	0.0578	0.0293	589	1930	175 μ	261 μ	0.077 0	0.116

37	0.00680	0.173	147	5.79	0.0462	0.0234	736	2410	140 μ	209 μ	$\frac{0.061}{7}$	0.0925
38	0.00600	0.152	167	6.56	0.0360	0.0182	945	3100	109 μ	163 μ	$\frac{0.048}{0}$	0.0720
39	0.00520	0.132	192	7.57	0.0270	0.0137	1260	4130	82.1 μ	122 μ	$\frac{0.036}{1}$	0.0541
40	0.00480	0.122	208	8.20	0.0230	0.0117	1480	4850	70.0 μ	104 μ	$\frac{0.030}{7}$	0.0461
41	0.00440	0.112	227	8.95	0.0194	0.00981	1760	5770	58.8 μ	87.5 μ	$\frac{0.025}{8}$	0.0387
42	0.00400	0.102	250	9.84	0.0160	0.00811	2130	6980	48.6 μ	72.3 μ	$\frac{0.021}{3}$	0.0320
43	0.00360	0.0914	278	10.9	0.0130	0.00657	2630	8610	39.4 μ	58.6 μ	$\frac{0.017}{3}$	0.0259

44	0.00320	0.0813	313	12.3	0.0102	0.00519	3320	10900	31.1 μ	46.3 μ	$\frac{0.013}{7}$	0.0205
45	0.00280	0.0711	357	14.1	0.00784	0.00397	4340	14200	23.8 μ	35.4 μ	$\frac{0.010}{5}$	0.0157
46	0.00240	0.0610	417	16.4	0.00576	0.00292	5910	19400	17.5 μ	26.0 μ	$\frac{0.007}{68}$	0.0115
47	0.00200	0.0508	500	19.7	0.00400	0.00203	8510	27900	12.1 μ	18.1 μ	$\frac{0.005}{33}$	0.00800
48	0.00160	0.0406	625	24.6	0.00256	0.00130	13300	43600	7.78 μ	11.6 μ	$\frac{0.003}{41}$	0.00512
49	0.00120	0.0305	833	32.8	0.00144	730 μ	23600	77500	4.37 μ	6.51 μ	$\frac{0.001}{92}$	0.00288
50	0.00100	0.0254	1000	39.4	0.00100	507 μ	34000	112000	3.04 μ	4.52 μ	$\frac{0.001}{33}$	0.00200