

DESIGN AND CONSTRUCTION OF SIREN FOR AMBULANCE

BY

ABDUL SHADRACH

2005/21985EE

**A THESIS SUBMITTED TO THE DEPARTMENT OF
ELECTRICAL AND COMPUTER ENGINEERING,
FEDERAL UNIVERSITY OF TECHNOLOGY MINNA,
NIGER STATE.**

**IN PARTIAL FULFILLMENT OF THE
REQUIREMENT FOR THE AWARD OF BACHELOR
IN ENGINEERING (B.ENG) ELECTRICAL AND
COMPUTER ENGINEERING DEPARTMENT.**

November, 2010.

DEDICATION

This project is dedicated to GOD Almighty, the great I AM, fountain and source of all wisdom, knowledge and understanding, my beloved parents, brothers and sisters. My fiancée Anna for her love support and encouragement my lovely mother for Ernest prayers and care. May God in his infinite riches reward you all.

DECLARATION

I, Mr. Abdul Shadrach, do solemnly declare that this piece of work is borne out of my ingenious conceptions and research and that, it has never been presented anywhere else prior to this moment either for a degree or any other purpose whatsoever.

ABDUL SHADRACH

.....

(Name of student)

APR 15/11/2010

(Signature and Date)

ENGR A.G. RAJI

(Name of H.O.D)

APR 11 (Jan. 11, 2011)

(Signature and Date)

PROF. ORIA USIFO

.....

(Name of supervisor)

.....

(Signature and Date)

ENGR DR. G. I. IGHAB

(Name of External Examiner)

APR 12/10

(Signature and Date)

ACKNOWLEDMENT

My profound gratitude and appreciation first to the one and only wise GOD the keeper and the sustainer of life who has kept and preserved my life to this time, I say all glory, honor and adoration to his name for ever. Support is the foundation for success in any human Endeavour, I can't but say a big thank to the following people:

To my mum Mrs. Dorcas Abdul for her motherly care and support, mummy God blesses and keeps you. My supervisor PROF. ORIA USIFO for giving me your time and attention to go through and correct this work, your words of advice gave me the courage to face the work to completion, Thank you sir. To my only Sister and Brothers, Sis Chenemi, Bro Monday and you all are a source of encouragement I love you all. To all my lecturers for the knowledge you have imparted in me, I am grateful. And to all my friends, I will love to say a big thank you.

ABSTRACT

This project, “Design and Construction of Siren for Ambulances” is built around a 555 timer integrated circuit. The project is design to meet the safety requirement that is lacking in many emergency units especially the medical sector. The 555 timer unit was interfaced with some other components to achieve the set objectives. Frequency is generated by the first 555 timer which is modulated by the second 555 timer. The output is immediately fed into the amplifying unit thus producing the required ambulance tone. It also incorporates the lamp flasher unit which indicates the proximity of the ambulance during traffic and emergency situations.

Table of contents

Title Page.....	i
Dedication.....	ii
Declaration.....	iii
Acknowledgement.....	iv
Abstract.....	v
Table of Contents.....	vi
Chapter One.....	1
1.1 Introduction	1
1.2 Brief History Of Siren.....	2
1.3 Aim and Objectives.....	3
1.4 Scope Of Study.....	3
1.5 Significant Of Study.....	4
1.6 Abstract.....	4
1.7 Design Methodology.....	4
1.8 Block diagram.....	5

Chapter Two:	6
2.1 Literature Review.....	6
2.2 Classification Of Siren.....	7
2.3 How siren works.....	7
2.4 Constructional Components.....	8
2.4.1 The Transformer.....	8
2.4.2 The Amplifier.....	8
2.4.3 Transistors.....	9
2.4.4 555 Timer Circuits.....	10
2.4.4.1 The Comparator.....	11
2.4.4.2 Flip Flop.....	13
2.4.4.3 The Resistors.....	13
2.4.4.4 The 555 Timer Pin Functions.....	14
2.4.4.5 Modes Of Operation Of A 555 Timer IC.....	14
2.4.5 The Transducer (The Speakers).....	18
2.4.6 The Regulator IC.....	19
2.4.7 Diodes.....	19
2.4.8 Resistors	20

2.4.9	Capacitors.....	21
2.4.10	The Bridged Rectifier.....	22
Chapter Three: Design and Construction.....		25
3.1	The Power Supply Unit.....	25
3.1.1	Transformer.....	26
3.1.2	Rectifier.....	27
3.1.3	The Filter.....	28
3.1.4	Voltage Regulator.....	29
3.2	Design of the oscillator unit.....	30
3.2.1	Tone Generator Circuit.....	30
3.2.2	Ambulance Tone Generator circuit.....	33
3.3	The Power Amplifying unit.....	35
3.4	The lamp flasher unit.....	38
3.5	The general circuit diagram.....	43
Chapter Four: Test, Result and Discussion.....		44
4.1	Testing	44
4.2	Design And Construction.....	44
4.3	Discussion Of Results.....	45

4.4 Precautions46

Chapter Five: Conclusion and Recommendation.....47

5.1 Problem faced.....47

5.2 Conclusions47

5.3 Recommendations.....47

References.....48

Index.....49

List Of Figures

Fig 1.1 Block diagram of an ambulance siren

Fig 2.1 the transformer

Fig 2.2 the practical, schematic and symbolic transistor diagram

Fig 2.3 The internal circuitry of a 555 timer IC

Fig 2.4 the comparator circuit

Fig 2.5 the flip-flop circuit

Fig 2.6 Astable configuration of a 555 timer

Fig 2.7 555 Astable output, a square wave

Fig 2.8 the waveform of a 555 duty cycle

Fig 2.9 Monostable Configuration

Fig 2.10 the transducer load of a 555

Fig 2.11 The 7812 IC Regulator

Figure 2.12 The Linear Resistors

Figure 2.13 The Capacitor

Figure 2.14 the practical diode bridge rectifier.

Figure 2.15 the bridge circuit

Figure 2.16 the bridge mode of operation

Figure 3.1 Power Supply Units

Figure 3.2 The transformer circuit.

Figure 3.4 positive conventional of current in a full bridge rectifier.

Figure 3.3 RC Filter-Rectifier

Figure 3.4 the regulator IC unit

Figure 3.3 the tone generator unit

Figure 3.4the ambulance tone generator

Figure 3.5The power amplifier unit

Figure 3.8 the lamp flasher unit.

Fig 3.9 The General Circuit Diagram Of An Ambulance Siren

CHAPTER ONE

INTRODUCTION

The Electronic siren systems are well known, perhaps the most prevalent public address system use by emergency and law enforcement vehicles. The Siren is a portable electronic warning device often mounted or placed on a moving vehicle, which produces a loud wailing sound. It has an audible sound which can thus be further improved for other purposes such as the alarm system. When used as the ambulance siren, the driver keys it by depressing a switch on the microphone, thus activating the microphone and allowing transmission.

In the past, such electronic sirens have generally included a single yelp oscillator or wail oscillator. The invention comprises a completely electronic siren. The electronic siren further includes means for mixing the signals from the yelp and wail oscillators, and an amplifier output circuit for broadcasting the output from the mixer through a suitable externally connected speaker. Thus, the output circuit of the electronic siren is useful as a public address system. The output from the electronic siren will provide either a horn or siren sound from the wail oscillator a push button yelp is provided for in the manual position if this connection is elected.

Brief details of how this ambulance siren tone is achieved are given later in the course of this write up. This project is aimed at providing some basic improvement on the previously existing siren systems. With some of the few features incorporated into the system design, it has made the system to find applications in various fields. Aside being used as an ambulance siren, with little modifications, it can also be used as a police siren, fire emergency siren, entertainment escorts for executives, and security alarm system.

1.2 BRIEF HISTORY OF SIREN

Sometimes before 1799, the first siren was invented by the Scottish natural philosopher (physicist) Robison. Robison's sirens were used as musical instruments; specifically, they powered some of the pipes in an organ. Robison's siren consisted of a stopcock that opened and closed a pneumatic tube. The stopcock was apparently driven by the rotation of a wheel. In 1819 an improved siren was invented and named by Baron Charles Cagniard de la Tour De la Tour's siren consisted of two perforated disks that were mounted coaxially at the outlet of a pneumatic tube. One disk was stationary, while the other disk rotated. The rotating disk periodically interrupted the flow of air from the fixed disk, producing a tone De la Tour's siren could produce sound under water suggesting a link with the sirens of Greek mythology; hence the name of the instrument.

Most modern sirens includes the civil defense, tornado sirens, or the sirens on emergency service vehicles such as ambulances, police cars and fire trucks. Most governments have standards for vehicle-mounted sirens. For example, in California, sirens are designated Class A or Class B. In non-technical terms, a Class A siren is so loud it can be mounted nearly anywhere on a vehicle. Class B sirens are not as loud and must be mounted on a plane parallel to the level roadway and parallel to the direction the vehicle travels when driving in a straight line.

Sirens must also be approved by local agencies. The approval is important because it ensures the devices perform adequately. Moreover, using unapproved devices could be a factor in determining fault if a collision occurs.

1.3 AIMS AND OBJECTIVES

As earlier mentioned in the general introduction, this project is aimed at designing and constructing a siren system that can produce and an ambulance siren tone or sound. This actually was the idea conceived. Because there has not been any work done to bring out a single electronic siren system that can perform this function, I decided to embark on this work with the following objectives.

The objectives are;

- ❖ To provide a basic means of avoiding traffic for the ambulance during emergency situations
- ❖ The flasher light on the ambulance creates awareness at night to the accident victims.
- ❖ The presence of siren on an ambulance also ensures that the ambulance gets to their destination within a short period of time.
- ❖ The output circuit of the electronic siren is useful as a public address system.

1.4 SCOPE OF WORK

This project can be further improved into a public address system, alarm and other sound related issues. Scope of this work is limited to the use of tone generator to produce audible sound. It further incorporates circuits such as oscillators, modulators, and amplifiers to synthesize a selected siren tone (i.e. the wail and the yelp sound) which is played through external speakers. The oscillator is adapted to operate manually by means of a push button. The amplifier output circuit is also utilized as an output circuit for a variable volume speaker. Additional amplifier structure for

increasing the output of the electronic siren may also be provided in accordance with the invention for further improvement.

1.5 SIGNIFICANCE OF STUDY

This project has a significant role to play in proffering a lasting solution to the availability of siren and to improve technicians and individuals that are capable of fixing all sirens related fault or issues. This project is unique as it combines the attribute of power amplifier in conjunction with an integral body of other components such as the 555 timers for generating the needed frequency of oscillation. It has very high definition for producing frequency within the range of 400 to 1200hertz and latest design in the market which reduces the cost of the entire circuitry.

1.7 DESIGN METHODOLOGY

The siren was design and constructed after carrying out serious research into the theoretical and analytical aspect by consulting textbooks, WebPages, various design manuals and consultations of learned individuals with vast practical experience. In construction, the 555 timer IC was used as the frequency generating components device. The timers IC were configured in astable mode by interfacing other passive components such as the resistors and capacitors. The first tone generated is fed into another astable configuration for modulation to the desired ambulance tone. Finally the tone is passed into the amplifier unit which consists of a transistor circuit and a sound transducer.

1.8 BLOCK DIAGRAM OF AN ELECTRONIC AMBULANCE SIREN.

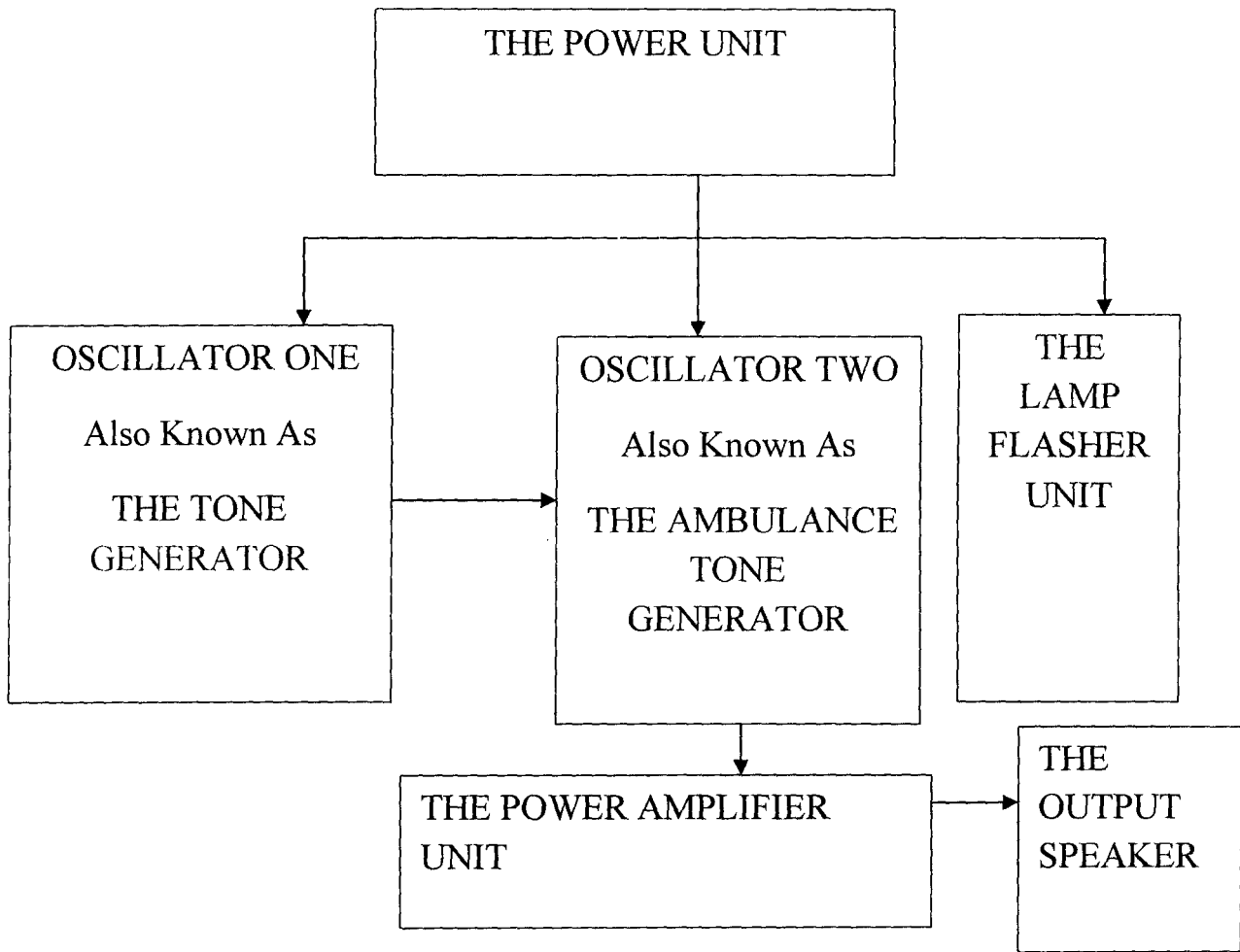

Figure 1.1 block diagram of an electronic ambulance siren

CHAPTER TWO

2.1 LITERATURE REVIEW

Most modern sirens includes the civil defense, tornado sirens, or the sirens on emergency service vehicles such as ambulances, police cars and fire trucks. Governments have standards for vehicle-mounted sirens. For example, in Nigeria sirens are designated Class A or Class B. In non-technical terms, a Class A siren is so loud it can be mounted nearly anywhere on a vehicle. Class B sirens are not as loud and must be mounted on a plane parallel to the level roadway and parallel to the direction the vehicle travels when driving in a straight line[4]

There are two general types of siren viz:

1. Pneumatic and
2. Electronic

Many fire sirens also pull double duty as tornado or civil defense sirens, alerting an entire community of impending danger. Most fire sirens are either mounted on the roof of a fire station, or on a pole next to the fire station. Fire sirens can also be mounted near government buildings, on top of tall structures such as water towers, as well as in systems; where several sirens are sporadically placed around a town for better sound coverage. Most fire sirens are single tone and mechanically driven by electric motors with a rotor attached to the shaft. Some newer sirens are electronically driven by speakers, though these are not as common. The most common types of sirens used include the Federal Signal Model 7, Model 2, Model 5, Thunderbolt 1003, Screamer and the Sterling (now Sentry) siren Model M, among others. [2]

2.2 CLASSIFICATION OF SIRENS

Sirens can be classified into two broad categories viz:

1. Class a siren-In non-technical terms, a Class A siren is so loud it can be mounted nearly anywhere on a vehicle.
2. Class b siren-Class B sirens are not as loud and must be mounted on a plane parallel to the level roadway and parallel to the direction the vehicle travels when driving in a straight line.

Sirens must also be approved by local agencies. The approval is important because it ensures the devices perform adequately. Moreover, using unapproved devices could be a factor in determining fault if a collision occurs.[4]

2.3 HOW SIREN WORKS

The electronic siren constitute of four modules, this include the power unit, the tone generator unit, the power amplifier unit and the flasher light unit.a regulated voltage supply is provided for the electronic siren. The regulated voltage supply provides a separate bias voltage for the electronic siren as well as the required regulated operating voltage from an approximately 12-volt

The tone Generator comprises of two 555timer circuits. The first 555timer in the tone oscillator unit is wired as a tone generator and the second 555 timer on the left is an astable multivibrator which produces the ambulance siren tone by modulating the tone supplied by the first timer. Its output is to frequency modulate the right 555timer. This causes the right timers frequency to alternate between 440Hz and 550Hz. The transistor is used to help strengthen the signal to the speaker. While the flasher unit constitute of a light indicator which flashes the light each time the circuit is powered

2.4 CONSTRUCTIONAL COMPONENTS OF SIREN

The electronic siren encompasses several major components during its design and construction. These major constructional components of siren include:

1. The transformer
2. The amplifier
3. The bridge rectifier
4. The capacitor filter
5. Regulator IC
6. The 555timer
7. Resistors
8. Transistors

2.4.1 THE TRANSFORMER

These are electrical devices which transfer electric energy from one circuit to another through magnetic means [9]. The electric energy is transferred without a change in frequency and power but there may be changes in the magnitudes of quantities such as voltage and current. A transformer is a device which uses the phenomenon of mutual induction to change the values of alternating voltages and currents. Losses in transformers are generally low and thus efficiency is high. Being static they have a long life and are very stable.

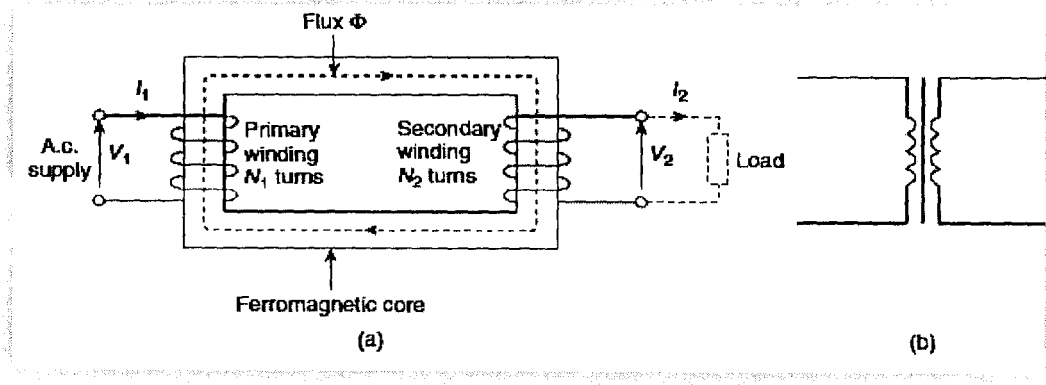

Figure 2.1 the transformer

2.4.2 Transistors

A transistor has two P-N junctions. These act as two diodes connected together with similar terminals (electrodes). They fall into two basic classes: Bipolar Junction Transistors (BJTs) and Field Effect Transistors (FETs). The BJTs are current controlled devices while the FETs are voltage controlled devices.

The BJT has three terminals: emitter, base and collector and these terminals are present in the two types of BJT which are NPN and PNP. It is because the transistor (BJT) makes use of both types of charge carriers (holes and electrons) that they are called bipolar. The transistor also comprises two p-n junctions and for this reason it is a junction transistor; hence the name – bipolar junction transistor [9]. The emitter is relatively heavily doped. The base region is relatively lightly doped and some electron-hole recombination takes place. The control of current from emitter to collector is largely independent of the collector-base voltage and almost wholly governed by the emitter-base voltage. See diagram below.

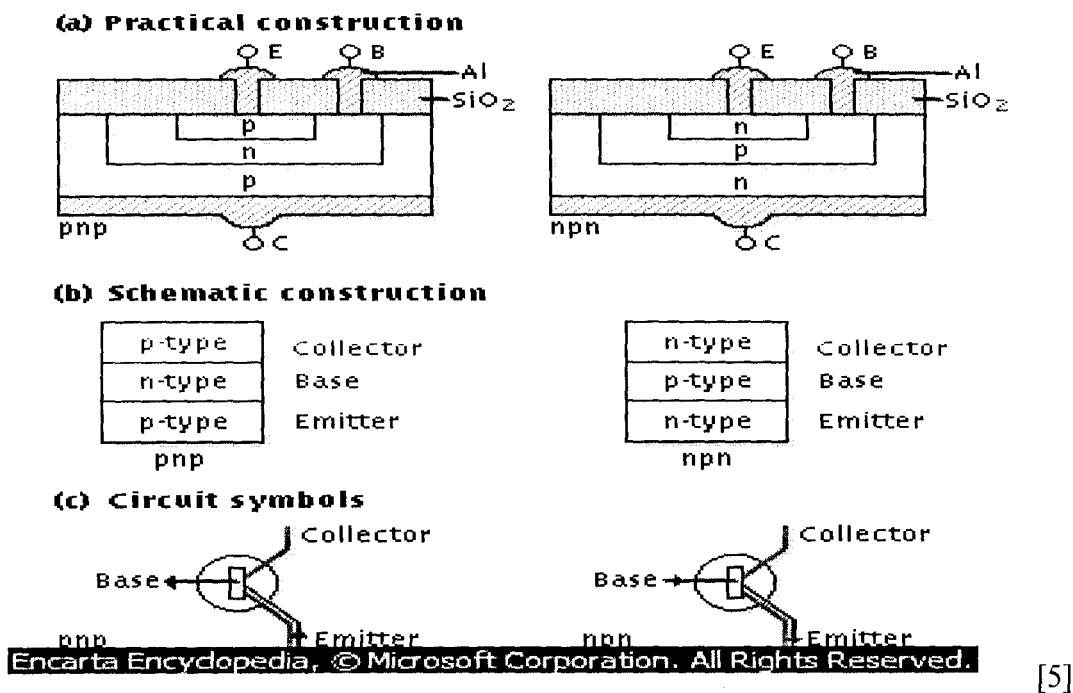

Figure 2.2 the practical, schematic and symbolic transistor diagram

2.4.4 THE 555 TIMER CIRCUIT IC

The LM555 is a highly stable device for generating accurate time delays or oscillation. Additional terminals are provided for triggering or resetting if desired. In the time delay mode of operation, the time is precisely controlled by one external resistor and capacitor. For astable operation as an oscillator, the free running frequency and duty cycle are accurately controlled with two external resistors and one capacitor. The circuit may be triggered and reset on falling waveforms, and the output circuit can source or sink up to 200mA

The Internal Circuitry of a 555 Timer IC [6]

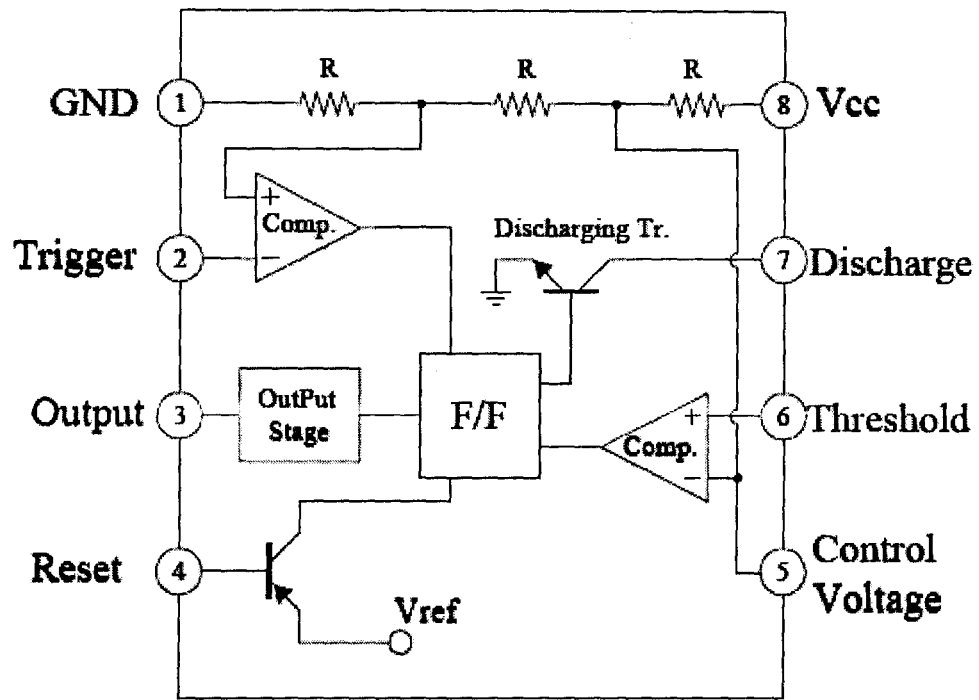

Figure 2.3 The internal circuitry of a 555 timer IC

The figure above shows the main internal circuit components of the 555 timer IC. It has the following active components:

2.4.4.1 The Comparator: the (-) input of comparator 1 is pegged at $\frac{2}{3} V_{cc}$ while the (+) of comparator 2 is pegged at $\frac{1}{3} V_{cc}$ (i.e., if pin 5 is not used).

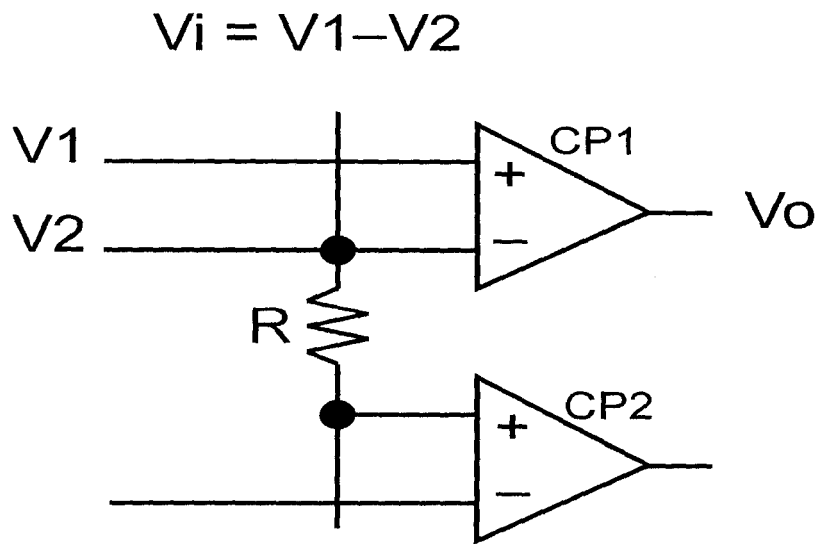

Figure 2.4 the comparator circuit

This establishes the internal voltage thresholds to which the externally connected inputs of the comparators will be compared. The behavior of the voltage levels of the external inputs of the comparators are determined by the external components connected to them, which are usually resistors and capacitors. The comparators are able to set/reset a flip-flop, which in turn determines whether the discharge transistor Q1 is 'on' or 'off'. [5]

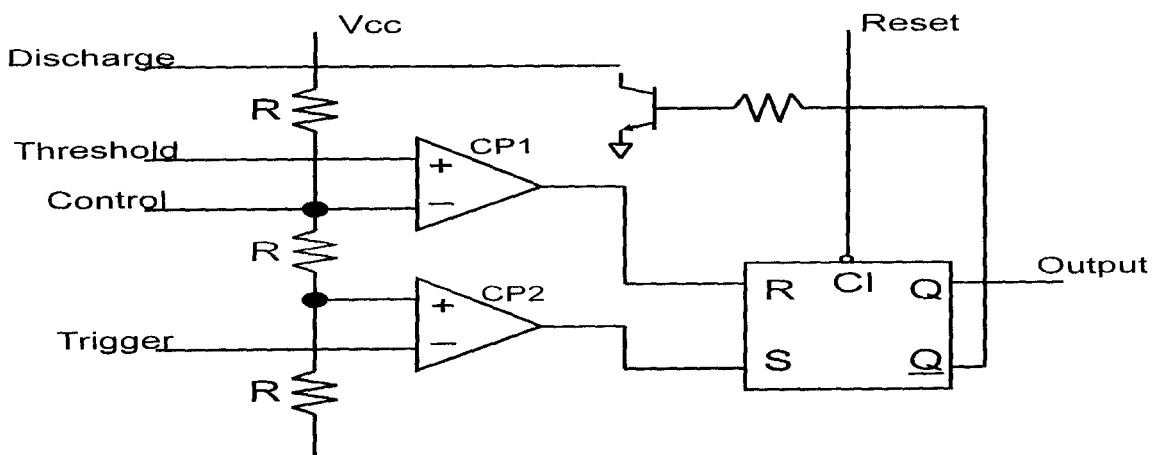

Figure 2.5 the flip-flop circuit

2.4.4.2 The Flip-Flop: A negative going pulse at pin 2 makes comparator 2's output go high, which causes the flip-flop to set, which outputs a '1' at pin 3. The flip-flop is reset in two ways: by a negative-going pulse at pin 4 or by allowing the (+) input of comparator 1 to exceed $2/3 V_{cc}$, usually by allowing a capacitor connected to pin 6 to charge up. The discharge path connected between pin 7 and pin 6 and the flip-flop state determine when and how the pin 6 capacitor discharges and, consequently, how the (+) input voltage of comparator 1 decays so that a new timing cycle may begin.

There are the equivalent of over 20 transistors, 15 resistors, and 2 diodes, depending on the manufacturer. Some of the more attractive features of the 555 timer are: Supply voltage between 4.5 and 18 volt, supply current 3 to 6 mA, and a Rise/Fall time of 100 nSec

2.4.4.3 The Resistors: The operation of the 555 timer revolves around the three resistors that form a voltage divider across the power supply, and the two comparators connected to this voltage divider. While the Threshold current determines the maximum value of $R_a + R_b$. For 15 volt operation the maximum total resistance for $R_a + R_b$ is 20 M Ω . The supply current, when the output is 'high', is typically 1 milli-amp (mA) or less. The initial monostable timing accuracy is typically within 1% of its calculated value, and exhibits negligible drift with supply voltage. Thus long-term supply variations can be ignored, and the temperature variation is negligible. [6]

2.4.4.4 THE PIN FUNCTION OF A 555 TIMER CIRCUIT

Trigger Input: when $< \frac{1}{3} V_s$ ('active low') this makes the output high ($+V_s$). It monitors the discharging of the timing capacitor in an astable circuit. It has a high input impedance $> 2M\Omega$.

Threshold Input: when $> \frac{2}{3} V_s$ ('active high') this makes the output low ($0V$). It monitors the charging of the timing capacitor in astable and monostable circuits. It has a high input impedance $> 10M\Omega$ Providing the trigger input is $> \frac{1}{3} V_s$, otherwise the trigger input will override the threshold input and hold the output high ($+V_s$).

Reset Input: when less than about $0.7V$ ('active low') this makes the output low ($0V$), overriding other inputs. When not required it should be connected to $+V_s$. It has an input impedance of about $10k\ \Omega$

Control Input: this can be used to adjust the threshold voltage which is set internally to be $\frac{2}{3} V_s$. Usually this function is not required and the control input is connected to $0V$ with a $0.01\ \mu F$ capacitor to eliminate electrical noise. It can be left unconnected if noise is not a problem.

The Discharge Pin is not an input, but it is listed here for convenience. It is connected to $0V$ when the timer output is low and is used to discharge the timing capacitor in astable and monostable circuits.

2.4.4.5 MODES OF OPERATION OF A 555 TIMER

The 555 timer operates in various modes among which include:

Astable Mode: An astable circuit produces a square wave. This is a digital waveform with sharp transitions between low (0V) and high (+Vs). The durations of the low and high states may be different. The circuit is called an astable because it is not stable in any state i.e the output is continually changing between 'low' and 'high'. As shown below

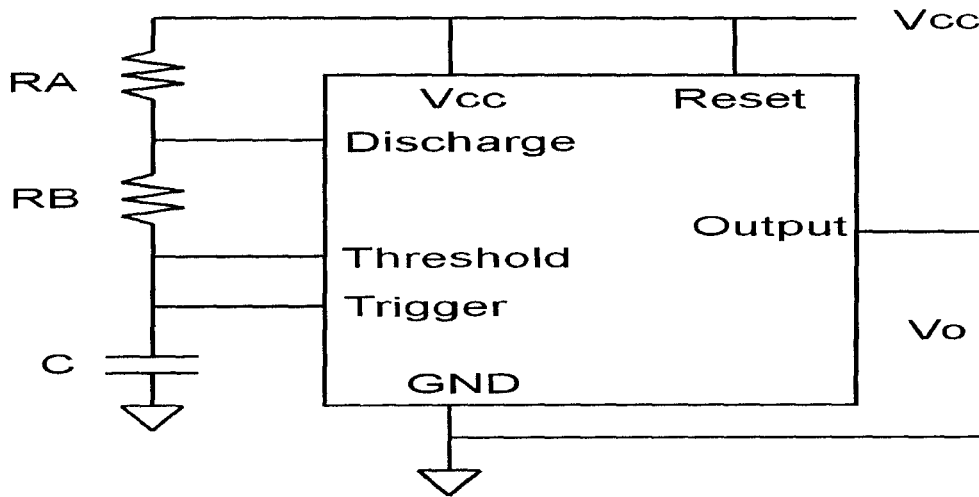

Figure 2.6 Astable configuration of a 555 timer

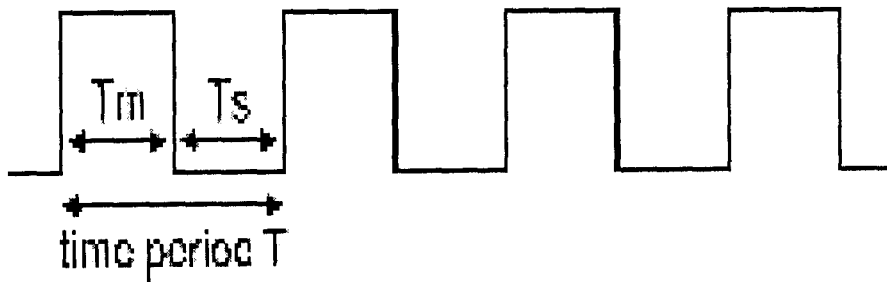

Figure 2.7 555 Astable output, a square wave

(T_m and T_s may be different) the time period (T) of the square wave is the time for one complete cycle, but it is usually better to consider frequency (f) which is the number of cycles per second.

$$T = 0.7 \times (R_1 + 2R_2) \times C_1 \quad \dots\dots\dots 2.1$$

And

$$F = \frac{1.4}{(R_1 + 2R_2) \times C_1} \dots\dots\dots 2.2$$

T = time period in seconds (s)

f = frequency in hertz (Hz)

R1 = resistance in ohms Ω

R2 = resistance in ohms Ω

C1 = capacitance in farads (F)

The time period can be split into two parts: $T = T_m + T_s$2.3

Mark time (output high): $T_m = 0.7 \times (R_1 + R_2) \times C_1$ 2.4

Space time (output low): $T_s = 0.7 \times R_2 \times C_1$ 2.5

Many circuits require T_m and T_s to be almost equal, this is achieved if R_2 is much larger than R_1 . [3]

Duty cycle

The duty cycle of an astable circuit is the proportion of the complete cycle for which the output is high (the mark time). It is usually given as a percentage.

For a standard 555/556 astable circuit the mark time (T_m) must be greater than the space time (T_s), so the duty cycle must be at least 50%:

$$\text{Duty cycle} = \frac{T_m}{T_m + T_s} = \frac{R_1 + R_2}{R_1 + 2R_2} \dots\dots\dots 2.7$$

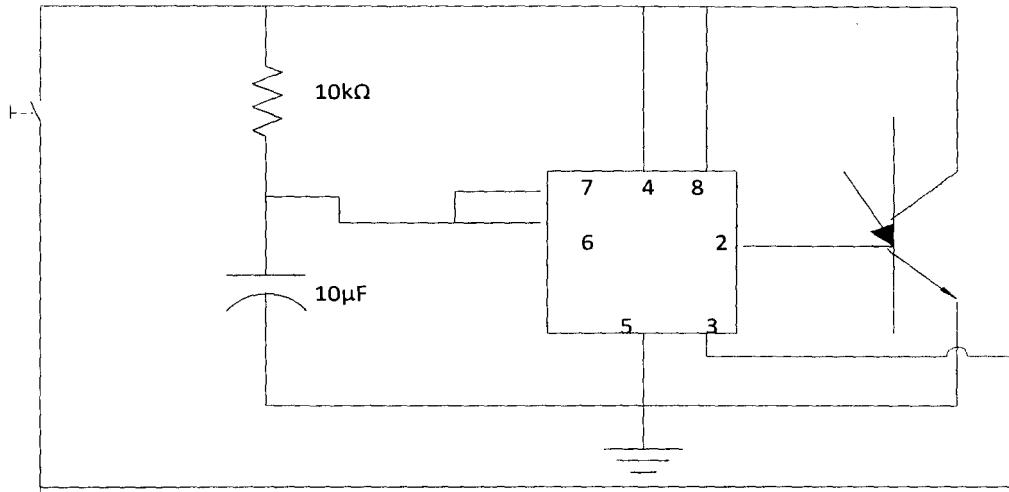

Figure 2.9 Monostable Configuration

2.4.5 THE SPEAKERS

The output of a standard 555 can sink and source up to 200mA. And it is sufficient to supply many output transducers directly, including LEDs (with a resistor in series), low current lamps, piezo transducers, loudspeakers (with a capacitor in series), relay coils (with diode protection) and some motors (with diode protection). The output voltage does not quite reach 0V and +Vs, especially if a large current is flowing.

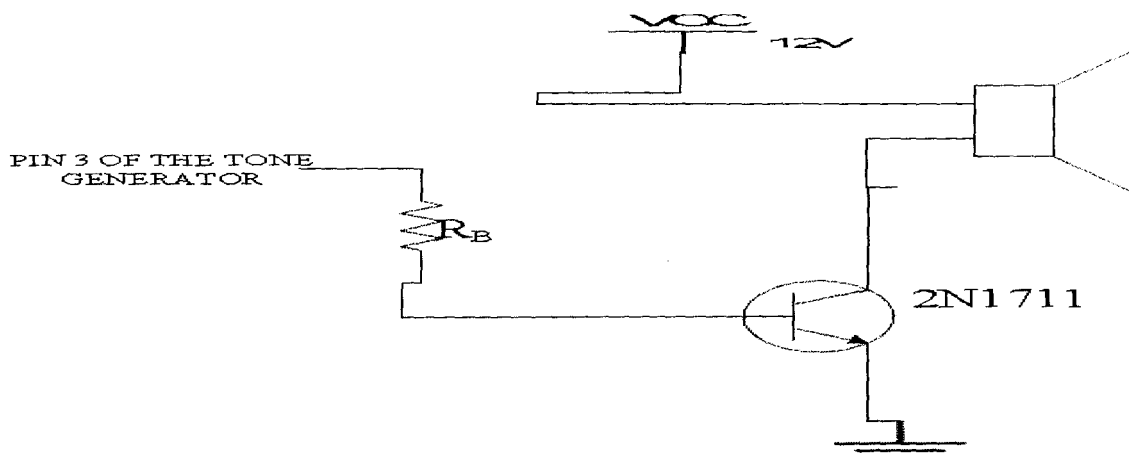

Figure 2.10 the transducer load of a 555

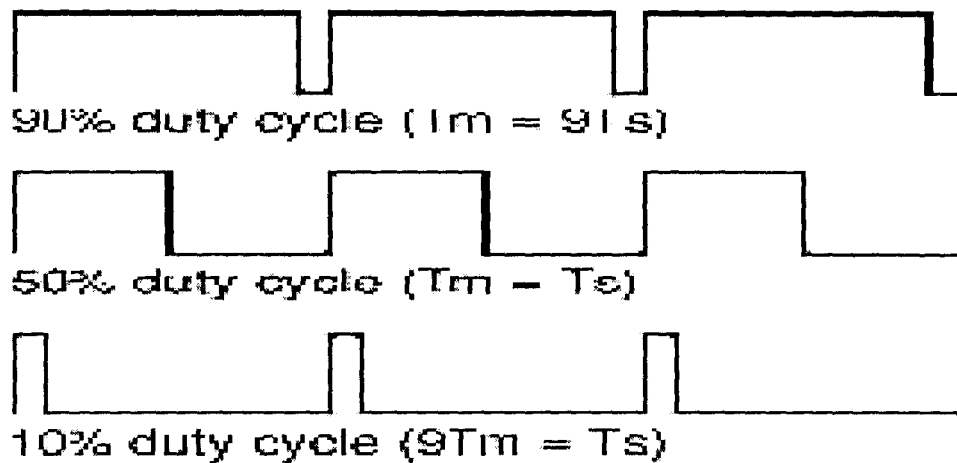

Figure 2.8 the waveform of a 555 duty cycle.

The Monostable Mode: In monostable mode, the timing interval, t , is set by a single resistor and capacitor, as shown below. Both the threshold input and the discharge transistor (pins 6 & 7) are connected directly to the capacitor, while the trigger input is held at $+V_{CC}$ through a resistor. In the absence of any input, the output at pin 3 remains low and the discharge transistor prevents capacitor C from charging. When an input pulse arrives, it is capacitive coupled to pin 2, the trigger input. The pulse can be either polarity; its falling edge will trigger the 555. At this point, the output rises to $+V_{CC}$ and the discharge transistor turns off. Capacitor C charges through R towards $+V_{CC}$. During this interval, additional pulses received at pin 2 will have no effect on circuit operation. The standard equation for a charging capacitor applies here. The capacitor will charge until its voltage reaches $(2/3) + V_{CC}$, [4]

2.4.6 THE REGULATOR IC (LM 7812)

The 7812 IC regulator serves both to remove the last of the ripple and to deal with variations in supply and load characteristics. It would be possible to use a smaller reservoir capacitor (these can be large on high-current power supplies) and then apply some filtering as well as the 7812 regulator, but this is not a common strategy. The extreme of this approach was to dispense with the reservoir capacitor altogether and put the rectified waveform straight into a choke-input filter. All this was achieved to ensure that the current waveform is smoother and consequently the rectifier no longer has to deal with the current as a large current pulse, but instead the current delivery is spread over the entire cycle. The downside is that the voltage output is much.6]

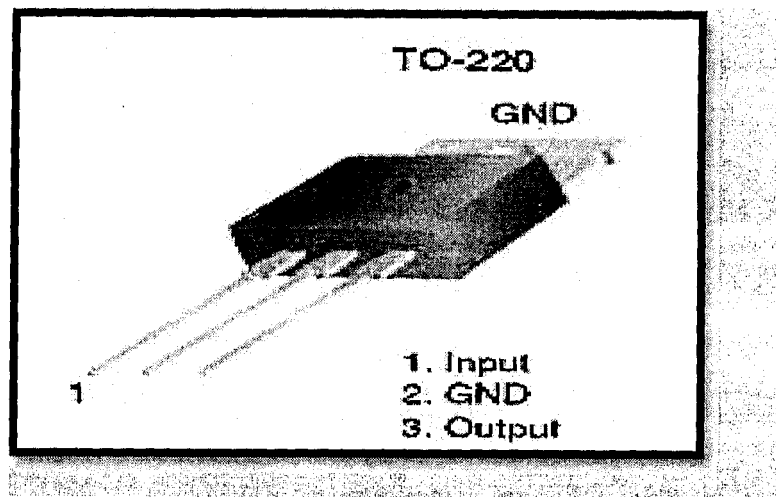

Figure 2.11 The 7812 IC regulator

2.4.7 DIODE

Diode is a electronic device that allows the passage of current in only one direction. The first such devices were vacuum-tube diodes, consisting of an evacuated glass or steel envelope containing two electrodes – a cathode and an anode. The diodes commonly used in electronic circuits are semiconductor diodes as will be used for the construction bridge rectifiers in this circuit. There are different diodes used in electronic

circuits such as Junction diode, Zener diode, Photo diodes, and tunnel diode. Junction diodes consist of junction of two different kinds of semiconductor material. The Zener diode is a special junction type diode, using silicon, in which the voltage across the junction is independent of the current through the junction.[6]

2.4.8 RESISTORS

All 555timers IC rely upon an external resistor and capacitor to determine the off-on time intervals of the output pulses.

Resistors generally offered Resistance which is a property of any object or substance to resist or oppose the flow of an electrical current. The quantity of resistance in an electric circuit determines the amount of current flowing in the circuit for any given voltage applied to the circuit, according to Ohm's law. The unit of resistance is the ohm, the amount of resistance that limits the passage of current to one ampere when a voltage of one volt is applied to it. The standard abbreviation for electric resistance is R and the symbol for ohms in electric circuits is the Greek letter omega, Ω . For certain electrical calculations it is convenient to employ the reciprocal of resistance, $1/R$, which is termed conductance, G. The unit of conductance is the mho, or ohm spelled backward, and the symbol is an inverted omega, \mathcal{U} .



Figure 2.12 The Linear Resistors

2.4.9 CAPACITORS

We prefer to use electrolytic capacitors over ceramic as they are more accurate. The important point to be noted is that although the resistors, mica capacitors are non-directional, Electrolytic capacitors have to be used in the circuit with terminals with the right polarity i.e. the terminal with marking of ground or -ve is always the anode(it has a shorter leg). If these are connected with opposite polarity, the capacitor won't work & would in fact burst![3] For a fixed arrangement of conductors and insulator, the ratio Q/V is a constant called the capacitance, C which is the ability of a capacitor to store charge. The relationship can be written thus:

$$C = \frac{Q}{V} \dots\dots\dots 2.11$$

But $Q = I \times T$

$$\Rightarrow C = I \times \frac{T}{V} \dots\dots\dots 2.12$$

Capacitors are used for different purposes which include tuned circuits, oscillators, power supplies, etc. The diagram below reveals the circuit symbol of capacitors found today.[12]

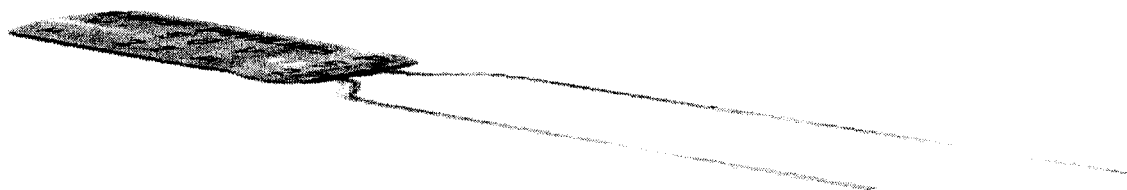

Figure 2.13 the capacitor

2.4.10 THE DIODE BRIDGE RECTIFIER

Diode Bridge is an arrangement of four diodes in a bridge configuration that provides the same polarity of output for either polarity of input. When used in its most common application, for conversion of an alternating current (AC) input into direct current a (DC) output, it is known as a bridge rectifier. A bridge rectifier provides full-wave rectification from a two-wire AC input, resulting in lower cost and weight as compared to a rectifier with a 3-wire input from a transformer with a center-tapped secondary winding.[3]

The essential feature of a diode bridge is that the polarity of the output is the same regardless of the polarity at the input. [7]

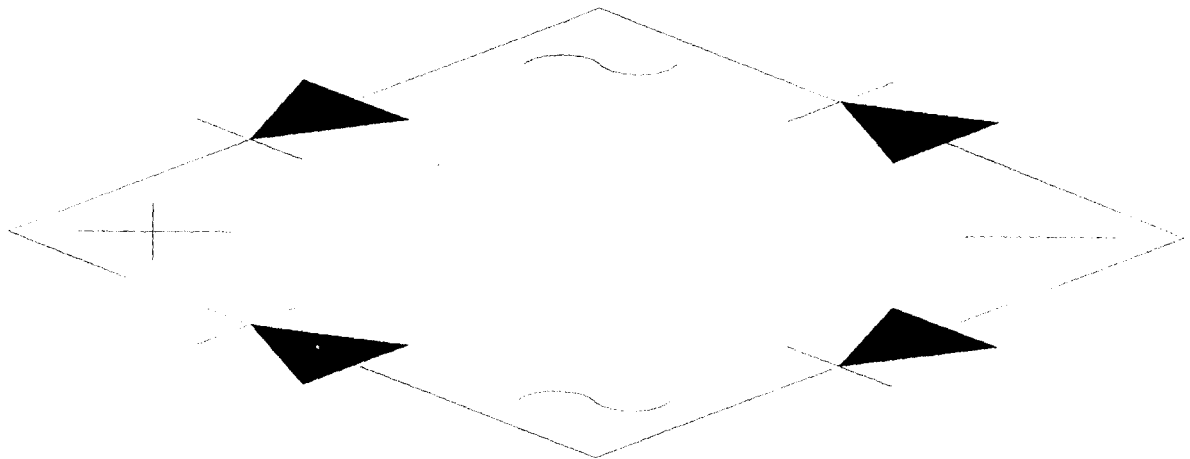

Figure 2.14 the practical diode bridge rectifier.

BASIC OPERATION

According to the conventional model of current flow originally established by Benjamin Franklin and still followed by most engineers today, current is assumed to flow through electrical conductors from the positive to the negative pole. In actuality, free electrons in a conductor nearly always flow from the negative to the positive pole. In the vast majority of applications, however, the actual direction of current flow is irrelevant. Therefore, in the discussion below the conventional model is retained.[5]

In the diagrams below, when the input connected to the left corner of the diamond is positive, and the input connected to the right corner is negative, current flows from the upper supply terminal to the right along the red (positive) path to the output, and returns to the lower supply terminal via the blue (negative) path.

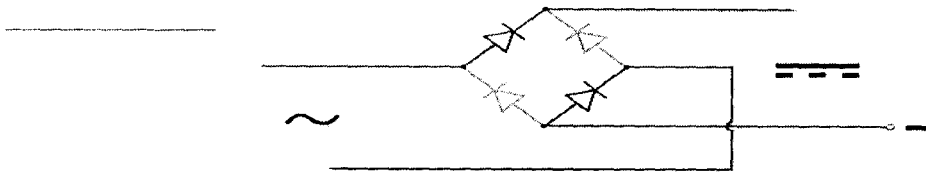

Figure 2.15 the bridge circuit

When the input connected to the left corner is negative, and the input connected to the right corner is positive, current flows from the lower supply terminal to the right along the red (positive) path to the output, and returns to the upper supply terminal via the blue (negative) path. [1]

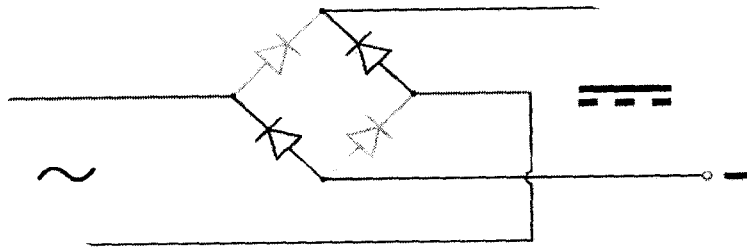

Figure 2.16 the bridge mode of operation

In each case, the upper right output remains positive and lower right output negative. Since this is true whether the input is AC or DC, this circuit not only produces a DC output from an AC input, it can also provide what is sometimes called "reverse polarity protection". That is, it permits normal functioning of DC-powered equipment when batteries have been installed backwards, or when the leads (wires) from a DC power source have been reversed, and protects the equipment from potential damage caused by reverse polarity.

Prior to the availability of integrated circuits, a bridge rectifier was constructed from "discrete components", i.e., separate diodes. Since about 1950, a single four-terminal component [1]

CHAPTER THREE

INTRODUCTION

For easy design and realization of the set objectives, top down design method was used. This involves breaking the whole conceived idea into manageable piece called the module. Hence the design of the individual stages of the ambulance siren consists of the following units:

1. The power supply unit
2. The oscillator unit(tone generator unit)
3. The power amplifier unit also known as the sound unit and
4. The flasher unit also referred to as the indicator unit.

With the above sub grouping, the design process was easier to carry out. The interconnection of the various subunits is as shown in the figure 3.1 below.

3.1 THE POWER SUPPLY UNIT

The power supply unit is the basic unit that supplies dc power to drive the siren system. The system was designed to operate on 12V supply that can be derived from either batteries or AC mains with suitable supply circuits as will be discussed in detail.

The power supply unit comprises of

- i. An AC supply
- ii. A step-down transformer
- iii. The full bridge rectifying circuit.
- iv. The filter circuits
- v. And the regulator IC. As shown in the figure 3.2 below.

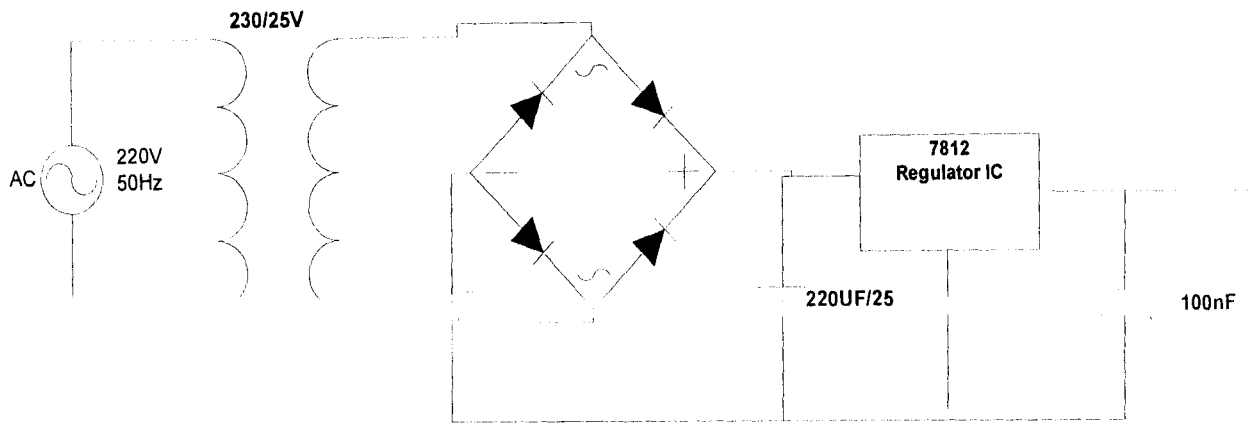

FIGURE 3.1 POWER SUPPLY UNITS

3.1.1 TRANSFORMER

The transformer is a device consisting of two closely coupled coils (i.e the secondary and the primary windings) it transforms AC voltages from one level to another. An AC voltage applied to the primary appears across the secondary, with a voltage multiplication proportional to the turn's ratio. A step down transformer of 220/12volts and a current rating of 500mA was used in this project.

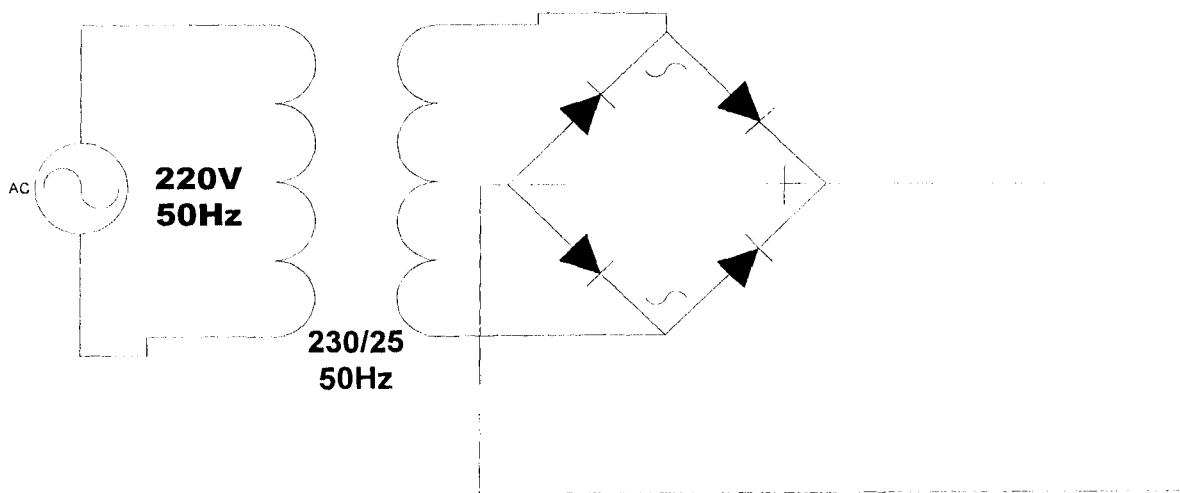

Figure 3.2 The transformer circuit.

3.1.2 Rectifier

Since every electronic equipment in this project makes use of DC voltage, the stepped down AC voltage from the transformer must be rectified to dc before it can be useful to the system. The rectifier converts alternating current (AC) to direct current (DC). To ensure the rectification of all the input, a bridge rectifier was used for the rectification purpose thus improving the efficiency of the system. The output of a full wave rectifier is a pulsating voltage. The rectification process converts both polarities of the input waveform to DC (direct current). To achieve the full wave rectification, four diodes were connected as shown in the figure below.

Figure 3.3 full-wave rectifier using 4 diode.

DESIGN SPECIFICATION.

Composition	Type	Part Number	Usage	Max. Operation Current And Reverse Voltage
Diode	Silicon	IN4001	Rectification	1A, 50V

According to the conventional model of current flow originally established by Benjamin Franklin and still followed by most engineers today, current is *assumed* to flow through electrical conductors from the positive to the negative pole.

When the input connected to the red terminal is positive, and the input connected to the blue terminal of the input side is negative, current flows from the upper supply terminal to the right along the red (positive) path to the output, and returns to the lower supply terminal via the blue (negative) path as shown in the figure below.

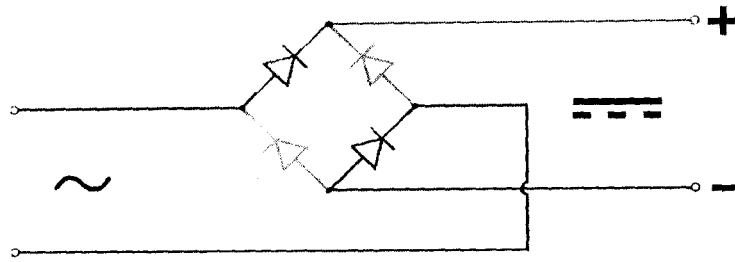

Figure 3.4 positive conventional of current in a full bridge rectifier.

Calculations

Since the rectifier is a full wave rectifier, the frequency is 50Hz the capacitor value of about 1000uf is used in order to give the required smoothing.

The reactance required is calculated thus,

$$X_C = 1/(2\pi fc) \dots\dots\dots 3.1$$

Therefore,

$$X_C = 1/(2\pi \times 1000 \times 10^{-6} \times 50)$$

$$X_C = 1.863\Omega$$

Hence a close value of 2Ω was chosen as the limiting resistor and the current though the smoothing capacitor is given by the expression, $2\pi fc$

3.1.3 The filter

In order to produce steady DC from the rectified AC supply, a smoothing circuit made up of capacitor was used. To achieve this, a smoothing capacitor was placed at the DC output of the rectifier. The peak output voltage of the supply transformer is = V_P ,

$$\text{Where } V_P = 2V_{RMS} \text{ and } V_{RMS} = 12\text{volts}$$

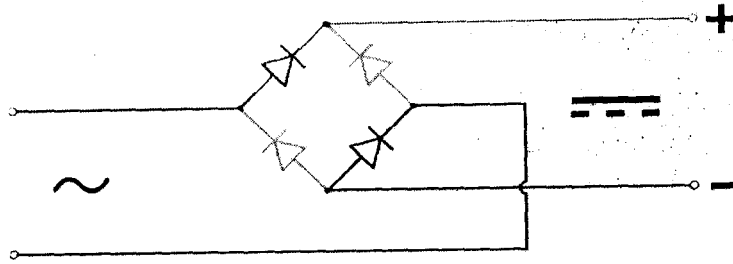

Figure 3.4 positive conventional of current in a full bridge rectifier.

Calculations

Since the rectifier is a full wave rectifier, the frequency is 50Hz the capacitor value of about 1000uf is used in order to give the required smoothing.

The reactance required is calculated thus,

$$X_C = 1/(2\pi fc) \dots\dots\dots 3.1$$

Therefore,

$$X_C = 1/(2\pi \times 1000 \times 10^{-6} \times 50)$$

$$X_C = 1.863\Omega$$

Hence a close value of 2Ω was chosen as the limiting resistor and the current though the smoothing capacitor is given by the expression, $2\pi fc$

3.1.3 The filter

In order to produce steady DC from the rectified AC supply, a smoothing circuit made up of capacitor was used. To achieve this, a smoothing capacitor was placed at the DC output of the rectifier. The peak output voltage of the supply transformer is = V_p ,

$$\text{Where } V_p = 2V_{RMS} \text{ and } V_{RMS} = 12\text{volts}$$

$$V_p = 12 \times 2$$

$$V_p = 24 \text{ volts}$$

The peak to peak current of the supply is $I_p = I_{DC} = 600 \text{ mA}$

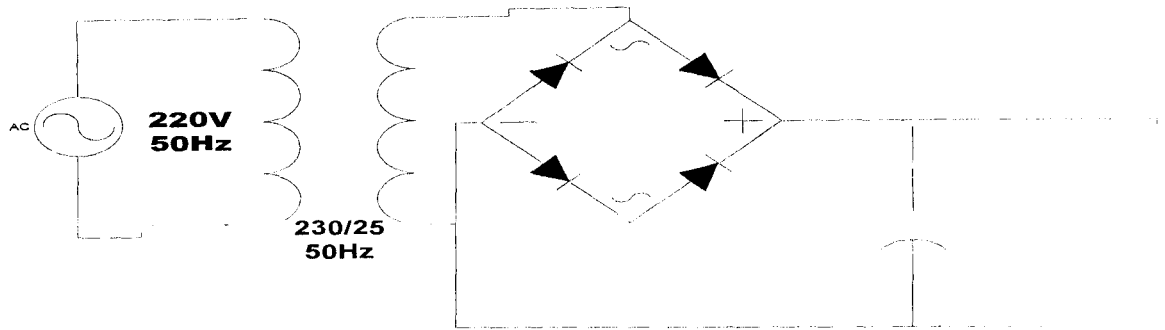

Figure 3.3 RC Filter-Rectifier

3.1.4 Voltage regulator

Due to variations in DC output voltage with changes in load or input voltage, a regulator is connected between the filter and the load. The regulator provides nearly constant DC output voltage even when variation in load occurs. For this project, a 7812 voltage regulator IC was used. As shown in the figure below.

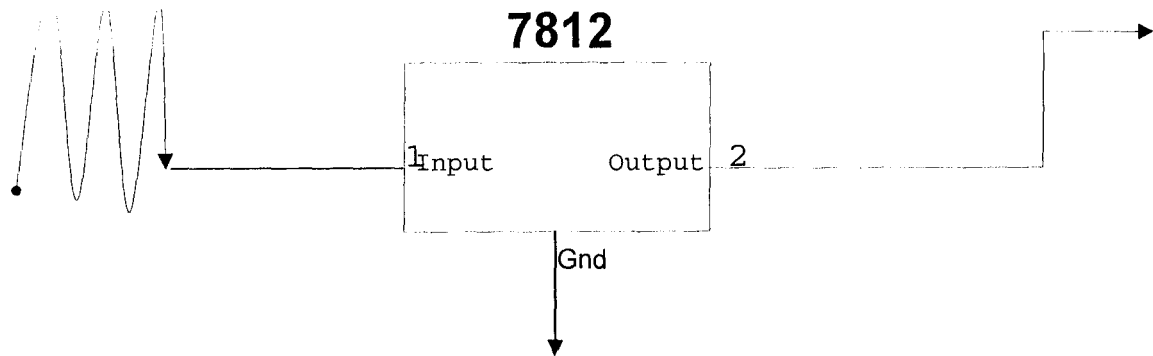

Figure 3.4 the regulator ic unit

3.2 DESIGN OF THE OSCILLATOR UNIT

With the 555 timer configured to operate in the astable mode free running multivibrator, two different circuits were obtained to generate the needed ambulance siren tone. One is the tone generator and the second is the ambulance tone generator.

3.2.1 THE TONE GENERATOR CIRCUIT

The heart of this system is the tone generator designed around IC₁. It is a fairly conventional 555 timer IC configured in a free running multivibrator astable mode as shown in the figure below.

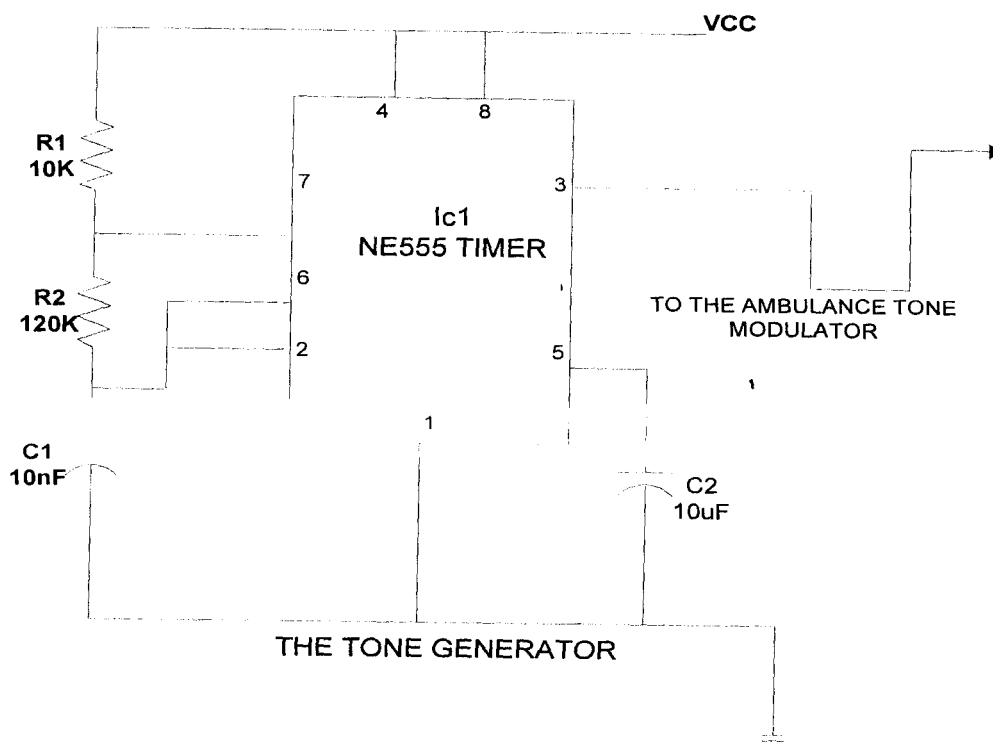

Figure 3.3 the tone generator unit

In astable mode, the '555 timer ' puts out a continuous stream of rectangular pulses having a specified frequency of 576Hz. Resistor R_1 is connected between V_{CC} and the discharge pin (pin 7) and another resistor (R_2) is connected between the discharge pin (pin 7), and the trigger (pin 2) and threshold (pin 6) pins that share a common node. Hence the capacitor is charged through R_1 and R_2 , and discharged only through R_2 , since pin 7 has low impedance to ground during output low intervals of the cycle, therefore discharging the capacitor. With the resistor value $R_1 = 10K$ ohms and a 10nF capacitor grounded. The grounded capacitor charges via the resistor R_2 as shown in the figure above.

CALCULATIONS

A duty cycle of 52% was chosen to obtain the value of the resistor R_2 . The duty cycle of a 555 timer IC configured in a multivibrator mode is defined by the expression thus:

$$\text{Duty cycle} = \frac{(R_1+R_2) \times 100}{(R_1 + 2R_2)} \dots\dots\dots 3.2$$

Where $R_2 =$ to be obtained, and R_1 is assumed to be 10×10^3 ohms

Therefore

$$52 = \frac{(10 \times 10^3 + R_2) \times 100}{(10 \times 10^3 + 2R_2)}$$

$$10 \times 10^3 + R_2 = 5.2 \times 10^3 + 1.04R_2$$

$$(1.04 - 1)R_2 = 10 \times 10^3 - 5.2 \times 10^3$$

$$0.04R_2 = 4.8 \times 10^3$$

$$R_2 = 4.8 \times 10^3 / 0.04 = 120K \text{ohms.}$$

$R_2 = 120K$ ohms. Therefore a resistor value of 120k ohms was used for R_2 .

To obtain the Frequency of oscillation i.e. the frequency produced by the oscillator, the expression below was used:

$$F_r = \frac{1.44}{(R_1 + 2R_2)C_1} \dots\dots\dots 3.3$$

Thus

$$F_r = \frac{1.44}{(10K + 2 \times 120K) \times 0.01 \times 10^{-6}}$$

$$F_r =$$

The time for which a high output is obtained

$$t_1 = 0.693(R_1 + 2R_2) C \dots\dots\dots 3.4$$

$$0.693(10k + 2 \times 120k) \times 0.01 \times 10^{-6}$$

$$t_1 = 0.9 \text{msec}$$

Time for which a very low output is obtained

$$t_2 = 0.693R_2 C_1 \dots\dots\dots 3.5$$

$$0.693(120k) \times 0.01 \times 10^{-6} \quad \text{Therefore, } t_2 = 0.83 \text{msec}$$

To obtain the total time of oscillation, Let T be the total time of oscillation

$$T = t_1 + t_2 \dots\dots\dots 3.6$$

$$T = (0.9 + 0.83) \text{ msec}$$

$$= 1.73 \text{msec}$$

3.2.2 THE AMBULANCE TONE GENERATOR

The second 555 timer IC makes up the oscillator use to generate the ambulance tone. The advance configuration or set up use to achieve the right period of oscillation for both high and low output is shown in figure 3.4 below.

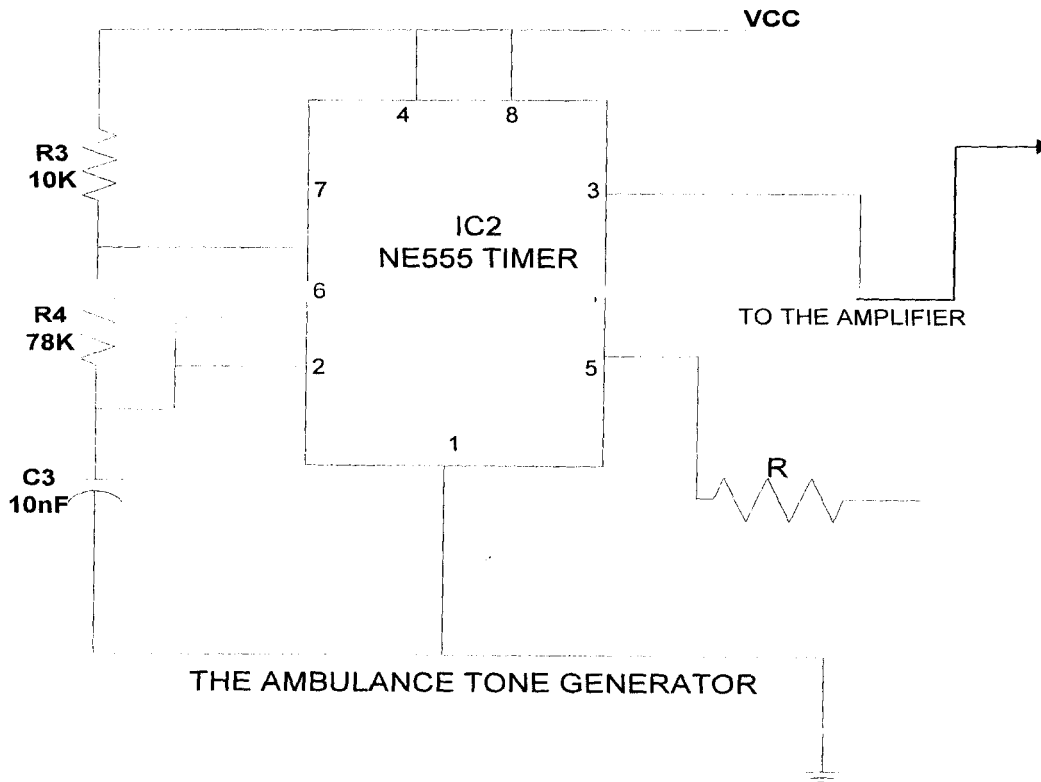

Figure 3.4the ambulance tone generator

CALCULATIONS

By Choosing a duty circle of 53%, capacitor value of 10microfarad, and a resistor $R_3 = 10\text{kohms}$. To obtain the value of R_4 , the same expression for the duty circle was used, thus:

$$\text{Duty cycle} = \frac{(R_1+R_2) \times 100}{(R_1 + 2R_2)} \dots\dots\dots 3.7$$

This implies that:

$$53 = \frac{(10 \times 10^3 + R_4) \times 100}{(10 \times 10^3 + 2R_4)}$$

$$10 \times 10^3 + R_4 = 5.3 \times 10^3 + 1.06R_4$$

$$(1.06 - 1)R_4 = (10 - 5.3) \times 10^3$$

$$0.06R_4 = 4.7 \times 10^3$$

Therefore,

$$R_4 = \frac{4.7 \times 10^3}{0.06}$$

Hence $R_4 = 78 \text{Kohms}$.

Therefore a commercial resistor value of 68k ohms was used for R_4 due to the availability in the market.

To obtain the Frequency of oscillation i.e. the frequency produced by the oscillator for the ambulance tone generation, the expression below was also used:

$$F_r = \frac{1.44}{(R_3 + 2R_4)C_4} \dots \dots \dots 3.8$$

Therefore,

$$F_r = \frac{1.44}{(10 + 68) \text{K} \times 10 \times 10^{-6}}$$

$$F_r = 1.85 \text{Hz}$$

The time for which a high output was obtained as

$$t = 0.693(R_3 + 2R_4) C_4 \dots \dots \dots 3.9$$

$$0.693(10k + 2 \times 68k) \times 10 \times 10^{-6}$$

$$T_1 = 0.54 \text{sec}$$

Time for which a low output is obtained

$$t = 0.693R_4 C_3 \dots\dots\dots 3.10$$

$$0.693(68k) \times 10 \times 10^{-6}$$

Where $K = 10^3$

$$t_2 = 0.47 \text{sec}$$

Total time of oscillation T

$$T = t_1 + t_2 \dots\dots\dots 3.11$$

$$T = (0.54 + 0.47) \text{msec}$$

$$= 1.01 \text{sec}$$

3.3 THE POWER AMPLIFIER UNIT

The purpose of an amplifier in this circuit is to amplify or strengthen the signal produced by the oscillators. Since the signal must be enlarged much more, enough to power a transducer.

A power transistor PMC D716/0 was used from the data specification book.

$$H_{fe}(\text{max}) = 20$$

The transistor is essentially a valve, like a water valve, that varies the amount of current flowing through the circuit based on the input signal from the source. A signal

from the 555 timer oscillator circuit causes the transistor to reduce or lower its resistance and allowing current to flow. However, the amount of current allowed to flow by the transistor is based on the size of the signal coming from the oscillator unit. Hence the frequency of the oscillator signal also determines how quickly the transistor operates.

The 1.85Hz tone from the first oscillator causes the transistor to open and close 1.85 times per second so, the transistor controls level (or amplitude) and frequency of the electrical current sent to the speaker, like a valve, and this is how it achieves its amplifying action. The figure below shows a circuit diagram for the power amplifier unit.

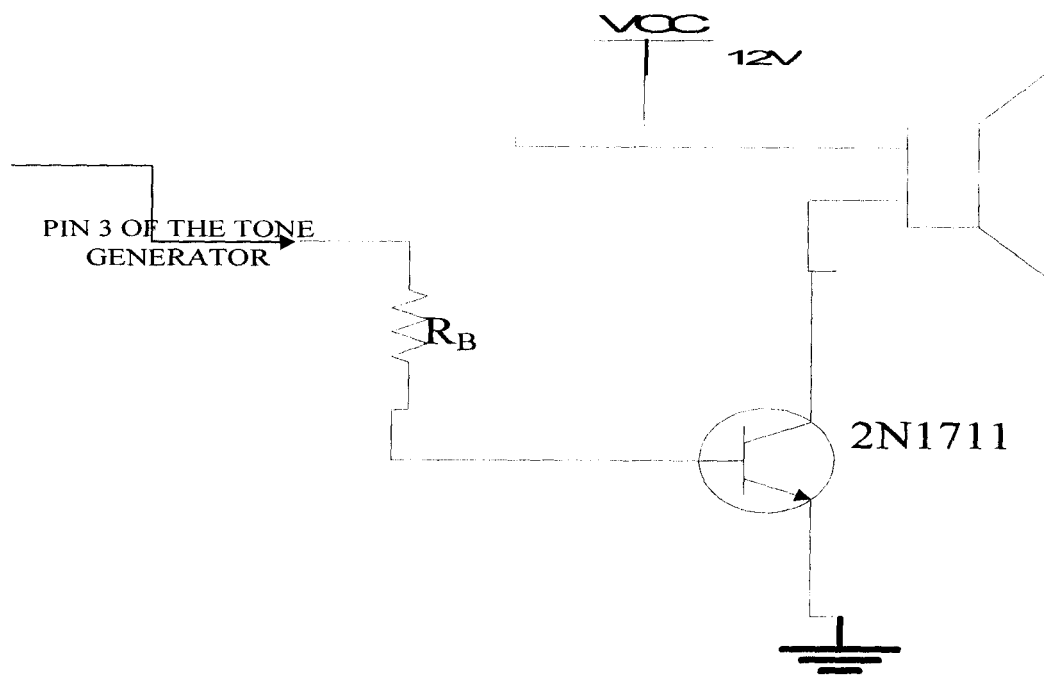

Figure 3.5The power amplifier unit

CALCULATIONS

Using $h_{fe}=12$ as the forward emitter gain. we have from the above diagram,

V_{in} = output voltage of the oscillator unit or circuit.

$$V_{in} = 8 \text{ volts,}$$

From the output expression of the transistor,

$$I_C = \frac{V_{CC}}{R_L} \dots\dots\dots 3.12$$

R_C = the resistance of the horn speaker which is equal to 25ohms

$$I_C = \frac{13.2}{25} = 0.53A$$

$$I_B = \frac{I_C}{h_{fe}} = \frac{0.53}{12} = 0.04A$$

From the transistor output expression,

$$V_{IN} = V_B + V_{BE} \dots\dots\dots 3.13$$

V_{BE} = base emitter voltage, V_B = base voltage

$$8 = V_B + 0.7$$

Therefore, $V_B = 8 - 0.7 = 7.3$ volts

$$R_B = \frac{V_B}{I_B} = \frac{7.3}{0.04} = 182.5 \text{ohms}$$

$$\text{The output power, } P = I^2 R \dots\dots\dots 3.14$$

$$P = 0.53^2 \times 25 = 7.02 \text{Watts}$$

3.4 THE LAMP FLASHER UNIT

The lamp flasher units of the ambulance siren consist of a 555 timer IC configured in a astable mode whose out put is connected to a transistor leading to the indicator (bulb or LED). As shown in the figure below.

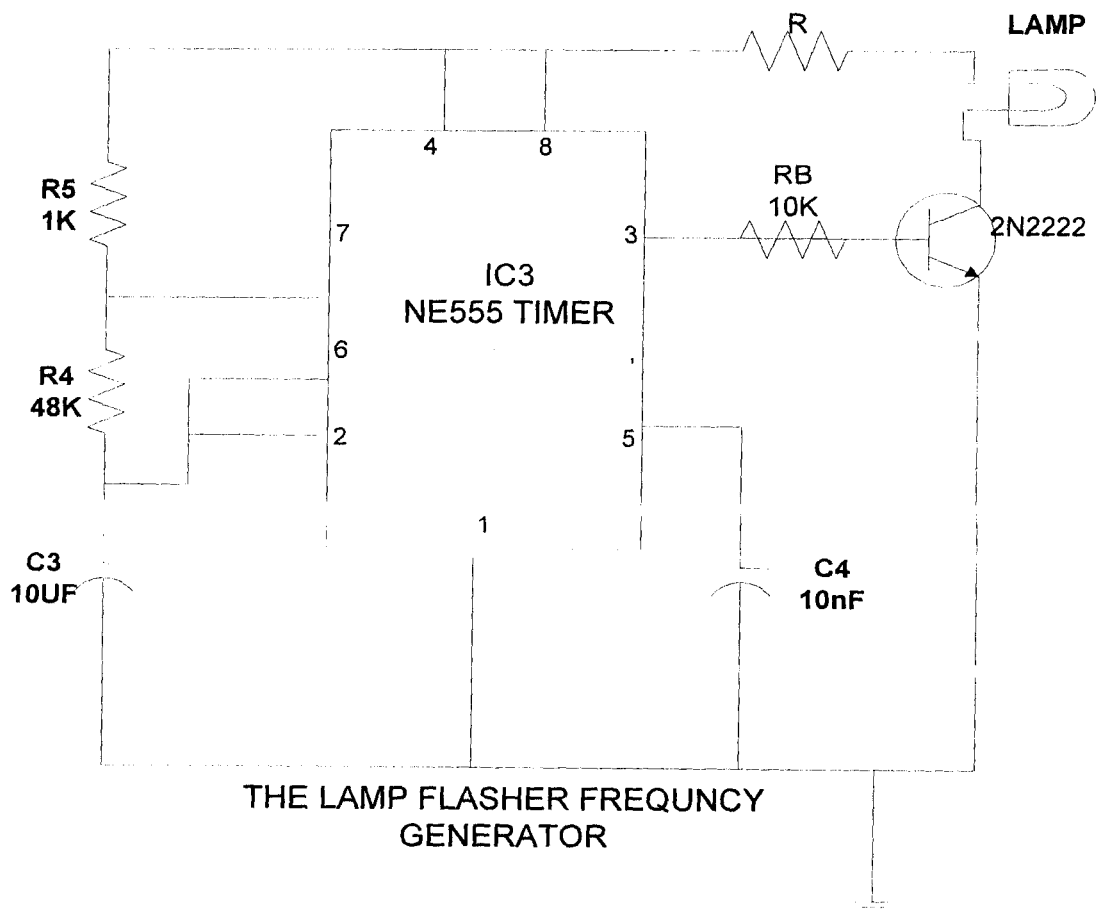

Figure 3.8 the lamp flasher unit.

Choosing a frequency F of 1.5Hz, capacitor $C_3 = 10\text{microfarads}$ and a resistor $R = 1\text{Kohms}$.

The frequency of oscillation

$$F_r = \frac{1.44}{(R_5 + 2R_6)C_5} \dots\dots\dots 3.15$$

Thus

$$1.5 = \frac{1.44}{(1K + 2R_6) \times 10 \times 10^{-6}}$$

$$1 \times 10^3 + 2R_6 = 1.44 \times 15 \times 10^{-6}$$

$$1 \times 10^3 + 2R_6 = 96 \times 10^3$$

$$2R_6 = 95 \times 10^3$$

$$R_6 = 95 \times 10^3 / 2$$

$$R_6 = 47.5 \text{Kohms}$$

$$F_r = 1.85 \text{Hz}$$

A commercial value of 46Kohms was used

$$\text{The period of oscillation, } T = 1/f \dots\dots\dots 3.16$$

$$T = 1/1.5 = 0.67 \text{sec.}$$

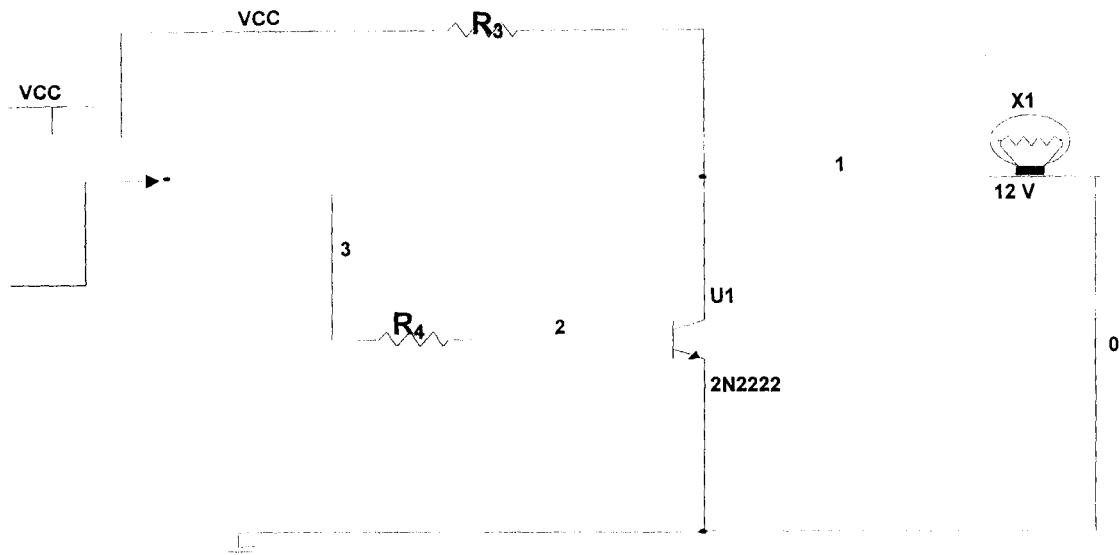

To calculate the value of R, we assumed an output voltage of 555 timer to be 9 volts and input current to 150mA.

$$\begin{aligned} \text{Therefore, } R_3 &= \frac{V_{CC} - 9}{150 \times 10^{-3}} \\ &= \frac{13.2 - 9}{150 \times 10^{-3}} \end{aligned}$$

$$R_3 = 2800 \text{ ohms} = 2.8 \text{ Kohms}$$

To calculate for R_B assuming a collector current

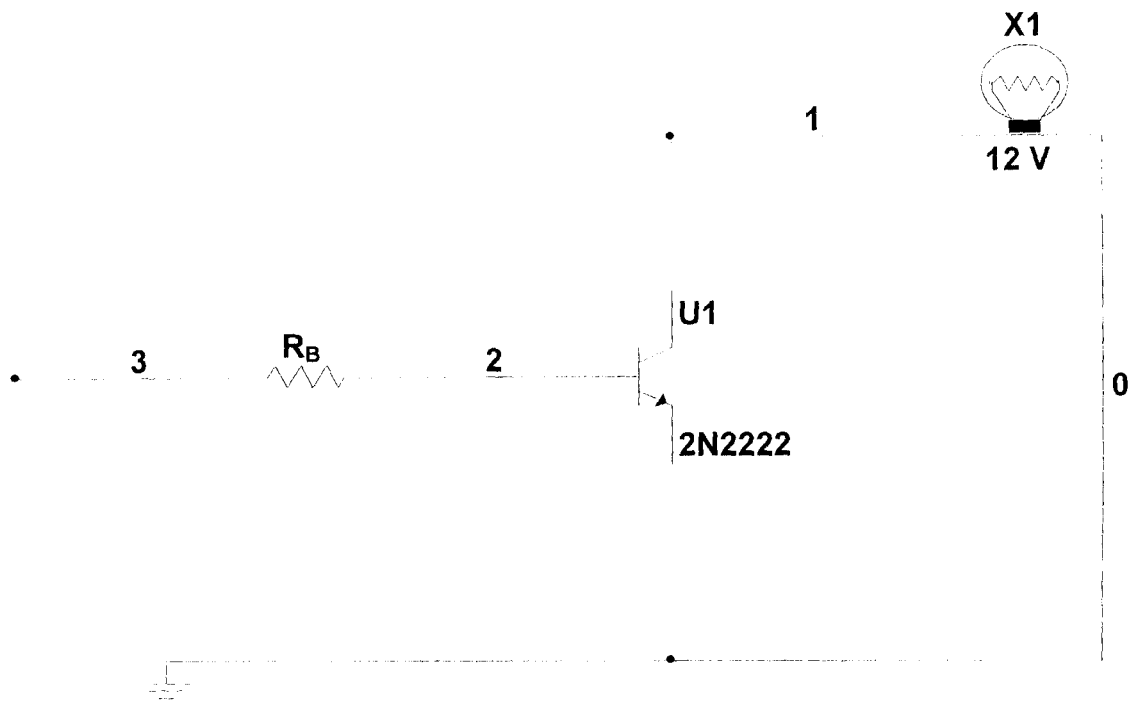

$$I_C = 0.8A$$

From the output expression,

$$V_{CE} = V_C + V_E \dots\dots\dots 3.17$$

where V_E = emitter voltage, V_C = collector voltage and V_{CE} = collector emitter voltage.

$$13.2 = 9 + V_E$$

$$V_E = 13.2 - 9$$

$$V_E = 4.2\text{volts}$$

From the input equation

$$V_{IN} = V_E + V_{BE} + V_B = 0.7 + V_E + V_B \dots\dots\dots 3.18$$

$$V_B = 8 - 4.2 - 0.7 = 3.1\text{volts}$$

Considering the data specification sheet, taking the gain H_{fe} for the T_{ip} 31 IC transistor to be 100,

$$I_B = h_{FE}/100$$

$$I_B = 0.8/100$$

$$= 8 \text{ m amp}$$

$$R_B = R_4 = 3.1/8 \text{ Ma} = 387.5 \text{ ohms}$$

380ohms was chosen as a commercial value.

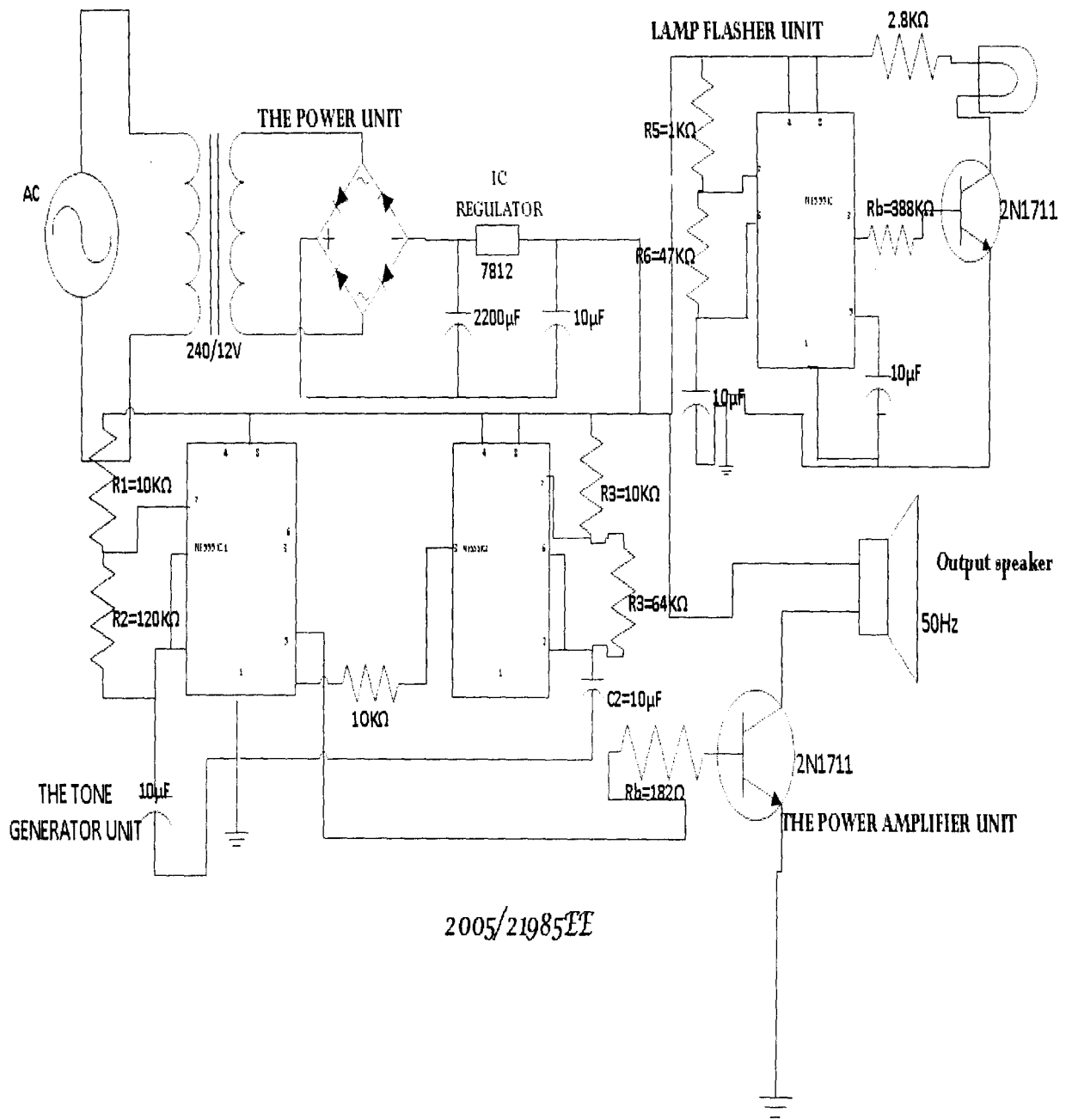

Figure 3.9 The General Circuit Diagram Of An Ambulance Siren

CHAPTER FOUR

TESTS AND RESULTS

4.1 TESTS.

It is one thing to construct but the actual beauty of a project is for the construction to pass all test and work to specifications. This project was physically and functionally realized. Adequate tests were carried out at each stage of the project in order to determine the outputs at the different stages. The tests were done prior to the soldering on the Vero-board in stages and after the whole work was coupled, a general test was carried out on the project. Different input voltages were recorded from the variable resistor and their corresponding output voltages were also measured and recorded at the transformer using some of the testing and troubleshooting processes listed below.

Digital Multimeter: The digital multimeter basically measures voltages, current, frequency, continuity, temperature and transistor polarity. Effective implementation of the design on the board requires adequate measurement of all the previously mentioned parameters.

4.2 DESIGN AND CONSTRUCTION

The design and implementation of this project was carried out using computer aided software known as the MULTISM. With each block designed and tested. This test was carried out on a breadboard result for each test was collected and recorded. The required and specified components were obtained and tested stage by stage and it was found to be functional on the breadboard within the design specifications.

The entire components were then transferred on a vero board. The stripes on the vero were adequately cleaned with methylated spirit in order to remove any conductor or dirt which might cause any form of short circuiting the circuit.

For easy replacements when necessary, the bases of the integrated circuits were soldered to the vero board instead of soldering the ICs directly to avoid overheating of the components. Great care was taken in handling the ICs to avoid any form of static induction during soldering to avoiding damaging the ICs.

4.3 DISCUSSION OF RESULTS.

After tests were carried out, the following were the results obtained at the different stages:

THE POWER SUPPLY UNIT

MODULE	OUTPUT	FREQUENCY
AC supply	220volts	50Hz
Transformer	25volts	50Hz
Rectifier	25volts	-
Regulator	12volts	-

THE OSCILLATOR UNIT

Module	Output	Frequency	High Time	Low Time	Total Time
Oscillator 1			0.9msec	0.83msec	1.73msec
Oscillator 2		1.85Hz	0.54sec	0.47sec	1.01sec

THE LAMP FLASHER UNIT

Module	Output	Frequency	Total Time
Oscillator		1.85Hz	0.67sec.
lamp	12volts	-	-

THE POWER AMPLIFIER UNIT

Transistors	$H_{fe} = 12$	8volts input	$I_C =$ 0.53A	$I_B =$ 0.04A	$R_B =$ 185.2 Ω	total power = 7.02watts
Transducer(speaker)	25 Ω resistance					

General test on coupled units:

It can therefore be deduced from the above table that a decrease in the output of the oscillator signal also results in a decrease in the general output supplied by the power amplifier system.

4.4 PRECAUTIONS.

Proper and neat soldering were carried out on each module of the model to avoid unnecessary short circuiting on the board. Components soldered on the Vero-board were spaced from each other to avoid short circuiting. The project was tested to determine its reliability and durability.

BILL OF QUANTITIES

COMPONENTS	UNITS	PRICE PER UNIT(NAIRA)	COST (NAIRA)
NE 555 timer IC	3	200	600
TRANSFORMER	1	500	500
CAPACITORS	9	50	450
VARIABLE RESISTORS	3	150	450
VERO BOARD	1	2000	2000
CASING	1	2000	2000
TOTAL	18	4,900	6,100

CHAPTER FIVE

CONCLUSION

5.1 PROBLEMS FACED.

Challenges encountered during the coupling and testing of the model were numerous. There were periods when the 555 IC kept burning frequently due to short circuiting and unbalanced voltage outputs. Obtaining the right frequency for the tone generator posed a whole lot of problem. Similarly getting the appropriate resistor and capacitor value to produce the required ambulance was also a serious challenge. At low voltage cut off, the transistors also kept burning as a result of large currents at the base.

5.2 CONCLUSSION

A modern ambulance siren sound was obtained at the end of the construction.

However, the sound/tone obtained was not as defined as expected.

The required frequency for the siren was realized. The electronic siren worked fine and was efficient.

5.3 RECOMMENDATION

For a clearer tone and more definitive feasibility of sound, the use of microcontroller should be incorporated. This will go a long way in eliminating noise and other variability factors.

5.4 SUMMARY.

This project was designed to generate a siren sound for ambulances. This was achieved by the use of two ne555 timers IC, one of which generates the ambulance

tone while the other generates the frequency tone generator. In order for the output transducer to be loud with a well-established sound output, a transistor is connected to the output of the ambulance tone generator. The model also incorporates the light flashing unit of the siren which serves as the indicator for the ambulance.

REFERENCES.

- Eng. Dr OriaUsifo, *Electrical Networks Design and Installation in Buildings, Fredorus LTD, Benin City, Nigeria, 2004*, pp iv, pp25-46
- . K. Ravi, K. O. George, Tay Chen Hui, *New School Physics, FEP International, Singapore, 1991*, pp 437.
- K. Ravi, K. O. George, Tay Chen Hui, *New School Physics, FEP International, Singapore, 1991*, pp 463.
- M. D. Abdullahi, *Lecture Notes on Electrical Installations and Design.*
- ALLAGMAGANI J.C. *Project report on Design and Construction of an Uninterrupted lighting system for F.U.T.Minna library, July 1991.*
- John O'Malley Ph.D, *Shaum's Outline of Theory and Problems of Basic Circuit Analysis, 2ed, McGRAW-HILL, 1992*, pp 28.
- Ian Sinclair, John Dunton, *Practical Electronics Handbook, 6ed, Elsevier Ltd, 2007*, pp 29.

2007, pp 157

O. N. Bishop, Basic Electronics, *Macmillan*, pp 40

B. L. Theraja, A. K. Theraja, My Textbook of Electrical Technology, *S. Chand and Company Ltd*, Ram Nagar, New Delhi, 1999, pp 1999.

B. L. Theraja, A. K. Theraja, My Textbook of Electrical Technology, *S. Chand and Company Ltd*, Ram Nagar, New Delhi, 1999, pp 1677.