

**DESIGN AND CONSTRUCTION OF A MULTI
SENSOR RADIO WAVE ALARM SYSTEM**

**BY
OKON ASUQUO A.**

REGISTRATION NUMBER: 98/7152EE

**PRESENTED TO THE DEPARTMENT OF
ELECTRICAL AND COMPUTER ENGINEERING,
IN PARTIAL FULFILLMENT OF THE REQUIREMENT
FOR THE AWARD OF BACHELOR OF ENGINEERING
(B. ENG.)**

**SCHOOL OF ENGINEERING AND
ENGINEERING TECHNOLOGY
FEDERAL UNIVERSITY OF TECHNOLOGY, MINNA,
NIGER STATE
November 2005**

ATTESTATION

This is to certify that this project "Design and construction of a multi sensor radio wave alarm system" was undertaken by Okon Asuquo A. in partial fulfillment of the requirement for the award of Bachelor of Engineering (B.Eng) in electrical and computer engineering of the Federal University of Technology, Minna, Niger state.



Mr. S. N. Rumala (supervisor)

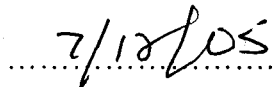

Date

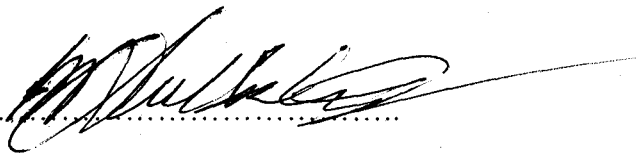

Engr. M. D. Abdullahi (HOD)

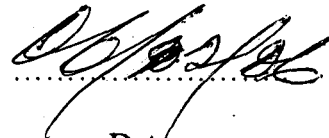

Date

.....
(External supervisor)

.....
Date

DECLARATION

I hereby declare that this project "Design and construction of a multi sensor radio wave alarm system" was conceived, investigated and actualized in its entirety by me. Information sources though have been duly acknowledged.



Okon Asuquo A.
(Student)

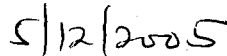

Date

ACKNOWLEDGEMENT

I want to express my heart felt gratitude to my parents Prof. E.E Okon and Mrs. A. E Okon for their moral and financial support and for bearing with me for the stress and demands I placed on them during the course of my undergraduate program. They taught me the meaning of hard work and never stopped challenging me to bring out the best in me, thank you very much. I also want to say a big thank you to my siblings; Lily, Ernest, Ebong, Edem and Mfon for their encouragement and support.

My sincere gratitude also goes out to my supervisor Mr. S. N. Rumala who went beyond the call of duty of a supervisor to challenge, encourage and draw out the creativity in me. Thank you sir, for your support and assistance. I must not fail to thank Prof. F. O. Akinbode for his tremendous support and invaluable assistance for which I remain most grateful.

Finally, I wish to thank my friends and colleagues, too numerous to mention. However special mention must be made of; Chikezie, Ngbede, Dele (Yomi), Innocent, Uche, Mlaku, Adele, Maxwell and Dooyum. I will always cherish the moments we shared together. You all affected my life in more ways than one. Above all you dared me to succeed.

DEDICATION

I dedicate this project work to the glory of the Everlasting God who kept and sustained me throughout my course of study and who is the source of my inspiration.

ABSTRACT

In recent times the use of alarm system as a security device and means of detecting crime has become increasingly widespread. More so, these alarm system have become sophisticated in design and application in order to match the increased level in crime. These days alarm systems are incorporated into various areas such as process monitoring and control, emergency warning system, industrial/domestic supervision, surveillance systems and a host of other but to mention a few.

This project titled "Multi sensor radio wave alarm system" therefore seeks to provide an efficient and effective means of crime detection. It transmits an audible beep or tone (alarm signal) on radio frequency as well as operating a speaker (or siren). The presence of an intruder is detected either by a light dependent resistor or a switch when it is opened. Thus this neat device can alert the police and the house owner when he is away from home by means of radio frequency transmission as well as neighbours via the aid of a speaker or siren.

The adaptability of this device makes it unique in that it can be incorporated in industries to monitor changes in parameter e.g. temperature, pressure, light intensity etc. by modifying the sensor to fit the particular application or condition. It can also be used in security outfits to monitor restricted areas and indicate the presence of any unauthorized person(s).

TABLE OF CONTENT

<i>Content</i>	<i>Pages</i>
Title page	i
Attestation	ii
Certification	iii
Acknowledgement	iv
Dedication.....	v
Table of contents.....	vii
Chapter one: Introduction.....	1
1.1 Statement of the problem.....	1
1.2 Aim and objective of the project.....	1
1.3 Operation of the multi sensor radio wave alarm system	2
1.4 Methodology	3
1.5Block diagram	5
1.6 Project outline.....	5
Chapter two: Literature review	7
2.1 Historical background of alarm system.....	7
2.2 Classification of alarm system and application	7
2.2.1. Alarm detectors	8
2.2.2 Alarm indicators.....	8
2.3 The 555 timer IC.....	10

2.4	The light dependent resistor	11
Chapter three: Circuit design and analysis		14
3.1	Power supply/ charging unit	14
3.1.1	Transformer	15
3.1.2	Rectifier	17
3.1.2.1	Ripple factor	20
3.1.3	Filter	21
3.1.4	Regulator	23
3.1.4.1	The LM317T adjustable 3-terminal voltage regulator	23
3.1.4.1.1	Application unit for LM317T	24
3.2	The Schmitt trigger trip dark detector/switch circuit	26
3.3	1 KHz tone generator	30
3.3.1	Charging and discharging a capacitor	34
3.3.1.1	During charging	34
3.3.1.2	Time constant	36
3.3.1.3	During discharge	37
3.4	The transmitter/ Rf amplifier	40
3.4.1	Mathematical expression for Fm wave	42
3.4.2	Analysis of the transmitter	43
3.4.3	Determining the modulation index	48
3.5	The output	49
Circuit diagram		53
Chapter four: Construction and testing		54

4.1	Construction	54
4.2	Testing.....	55
4.2.1	Results	56
4.2.2	Difficulties encountered	56
	Photographs	57
	Chapter five: Conclusion and recommendation	60
5.1	Conclusion.....	60
5.2	Recommendation.....	60
	References	62
	Appendix.....	63

CHAPTER ONE

INTRODUCTION

1.1 STATEMENT OF THE PROBLEM

Security of lives and property is of extreme importance to nations, corporate organizations and individuals. No meaningful development and technological advancement can take place in the absence of peace. For this reason, the most developed nations in the world vote a sizeable portion of their annual budget on defense and national security. This also explains why the ministry of defense often gets the lion's share of the annual budget in Nigeria.

The September 11, 2001 attacks on the United State of America popularly referred to as 9/11 and also most recently the London bombing underscores the very essence of effective and efficient security. Nations that thought themselves to be very secure and impenetrable have suddenly realized that they have a soft under belly. To this end, they are having a review of their security policies and in some cases putting in tougher security measures and even over hauling their entire security system.

The surest bet therefore to providing security is putting in place an effective, efficient and reliable means of crime detection, as crimes are better handled if there can be prevented or nipped in the bud before they are committed.

1.2 AIM AND OBJECTIVE OF THE PROJECT

The aim of this project is to design and construct a multi sensor radio wave alarm system.

This simple device seeks to provide a means of security and crime detection that is effective and efficient. It equips the owner of the house with the means of monitoring the

security status of his house when he is within or away from home as well as alerting the police and neighbours when the security at his premises is breached.

With appropriate modification of the sensor, this device can be adopted in industries for monitoring processes and parameters in production to indicate or detect an abnormal condition.

1.3 OPERATION OF THE MULTI SENSOR RADIO WAVE ALARM SYSTEM

The multi sensor radio wave alarm system is designed to transmit alarm signals via radio frequency and through a speaker as well.

The sensors or detectors include a light dependent resistor and a normally closed magnetic reed (contact) switch which serve as inputs into the circuit. When the presence of an intruder is detected either by obstructing the illumination of the LDR (dark triggered) or by opening a door or window which opens the contact switch, a voltage level known as trigger voltage is applied to the base of a Schmitt trigger which triggers and operates in 1 of 2 modes. These modes are namely the latched and unlatched modes. In the latched mode; the alarm system is triggered once activated and remains triggered even after the trigger voltage has been removed while the unlatched mode only operates for the duration the trigger voltage is applied.

The output of the Schmitt trigger is used to power or activate a 1 kHz tone generator which provides the modulating signal. The tone generator is achieved by means of a 555 timer IC connected in the astable mode which in essence is an oscillator. Hence the 555 timer serves as an audio frequency oscillator.

Arising from the output of the tone generator are connected a speaker and transmitter units. First the 1 kHz tone is employed to drive an 8Ω speaker through a $10k\Omega$ limiting resistor and a single stage amplifier. A loud sound is heard from the speaker (or siren) each time the circuit is activated. Secondly the output from the tone generator is used to modulate a radio frequency

signal which is generated by a tuned parallel LC tank circuit. The modulator is a C9014 npn transistor connected in common base configuration. The output from this modulator is amplified by an RF amplifier coupled to an antenna for radiation into space. The antenna serves to transmit the signal to a designated location or even a nearby police station for instance, in the event of an intrusion.

The circuit is powered by 12 volt ac mains supply and a 12 volt all battery in addition. When the ac supply is present, the dc supply is disabled but as soon as the ac supply is interrupted, the dc supply immediately takes over serving as an alternative independent power source as well as a back up for the ac supply. In this way uninterrupted power is supplied to the circuit at any point in time since it is important that the alarm should always be operational. When in standby mode, the ac supply charges up the 12v battery. A given LED indicator is employed to indicate when the circuit is powered.

It should be noted that the circuit remains inactive as long as no trigger voltage is applied to the base of the schmitt trigger. The circuit immediately comes active as soon as a trigger voltage is present.

1.4 METHODOLOGY

For ease of design and construction, the circuit is divided into five (5) sections viz:

- i. The power supply/charging unit
- ii. The Schmitt trigger trip dark detector/switch unit
- iii. The tone generator unit
- iv. The transmitter/Rf amplified unit
- v. The speaker and antenna unit.

The power supply/charging unit consists of a 12V ac mains supply and a 12V battery source. An LM317T regulator is employed to give a regulated 12V output from the power section into the circuit. The dc supply provided by the battery provides back up for the ac supply. The ac supply charges the battery as well.

The detector/sensor unit uses a light dependent resistor (LDR) and a contact switch to activate a Schmitt trigger thus providing an input into the circuit. The LDR operates when it detects darkness by reason of an obstruction to a light source which keeps it idle when illuminated.

The reed switch which is normally closed activates the circuit when a door or window as the case maybe is opened. Also a mode select/reset button toggles between the different modes of the circuit and also resets the circuit.

A tone generator which is designed from an astable multi vibrator using a 555 timer IC is connected to the output of the Schmitt trigger. Thus the tone generator is only activated when the Schmitt trigger is triggered. A pulse of 1 kHz is generated by the astable circuit which operates as an oscillator.

The output of the tone generator (pin 3) is connected to an FM transmitter and a speaker unit as well. The modulating signal (1 kHz beep) is connected to the transmitter through a modulator, which combines the radio frequency signal and the modulating signal: thereafter the modulated signal is amplified by an Rf amplifier before it is sent to the antenna.

Finally the output stage comprises of the antenna that radiates the modulated signal sent to it and the speaker unit. The amplified modulated signal is radiated from the antenna to a designated location or a nearby police station. The second output from pin 3 of the 555 timer is connected to an 8Ω speakers which serves as a transducer, converting the electrical signal (1

kHz) into an audible sound. The sound is loud enough to alert neighbours about the presence of an intruder.

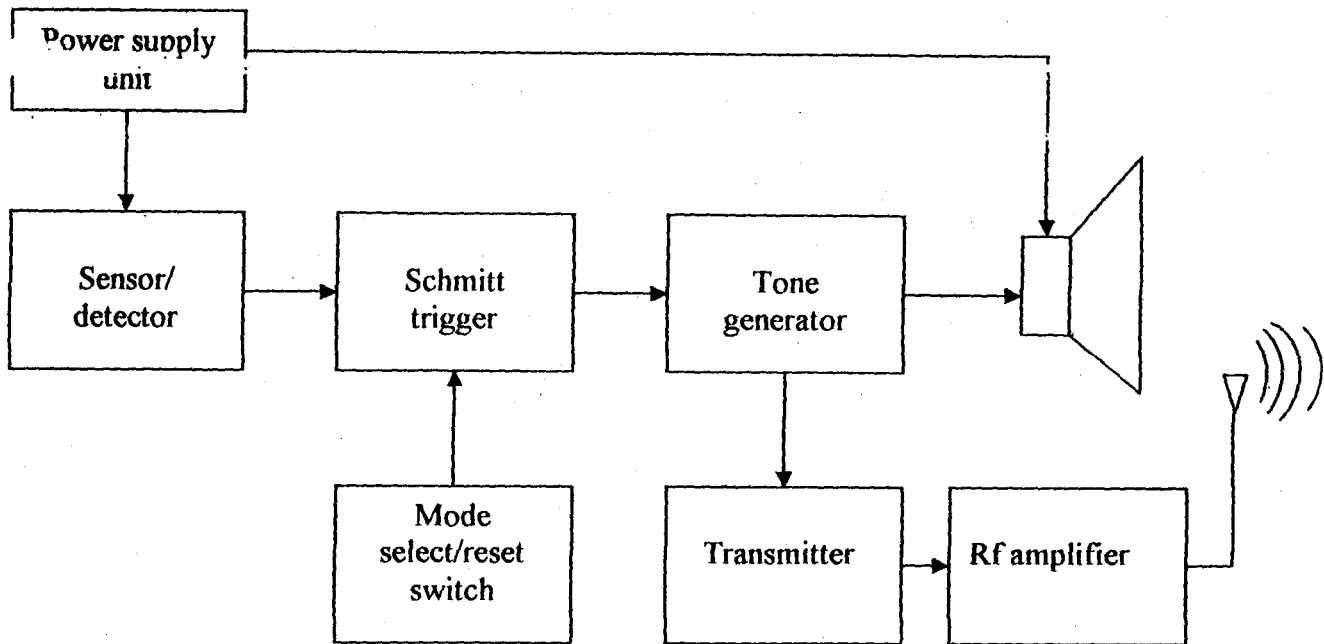

1.5 Block diagram representation of the circuit

1.6 PROJECT OUTLINE

This project seeks to design a neat and portable device which can detect the presence of an intruder or unwanted person and provide an effective and efficient means of alerting security personal or person (s) for assistance. To fulfill this objective, this project has been divided into chapters as follows:

Chapter one deals with the statement of the problem, the aim the project, mode of operation, the methodology involved, the block diagram representation of the circuit all of which form the introduction. Chapter two contains the literature review which gives the history of alarm systems classification of alarm systems and other related materials used in the course of the project. Chapter three deals with the circuit design and analysis. Chapter four entails construction and testing, the results obtained and some of the difficulties encountered. Finally,

chapter five caps it all up with the conclusion, recommendation and the reference materials consulted.

CHAPTER TWO

LITERATURE REVIEW

2.1 HISTORICAL BACKGROUND OF ALARM SYSTEMS

Looking at the various alarm systems present today, one can easily be misled into thinking of them as fairly new inventions. But their evolution dates back to almost a century and a half of hard work and ingenuity.

The system was first invented around 1853, and except for the telegraph invented in 1844, it was the earliest commercial application of electricity thereby predating even the telephone (1876).

Edwin Holmes, who founded the New York City Company pioneered the first commercial use of alarm and telephone systems and in the process became the manufacturer of the world first insulated wire conductor. To achieve this feat required that he had to install his own connection (poles and wiring) between alarm-protected sites and his central office.

So successful were these inventions that with his establishment in Boston and New York in 1858, his clientele soon included such prestigious firms as Bowery Bank, the manufactures Bank, the Bank of Montreal and an impressive list of other residential clients. In 1872, Holmes developed the electric safe cabinets thus providing jewelers and bankers with a means to safe guard their safe and vault assets.

2.2 CLASSIFICATION OF ALARM SYSTEM AND APPLICATIONS

Alarm systems are systems which operate a warning device after the occurrence of an abnormal or dangerous condition. Alarm systems are used to signal undesirable or dangerous situation such as the presence of an intruder or the existence of a runaway condition in a

petroleum refinery process. In factories, these systems signal such things as excessive process temperature or pressure or rapid change in process condition.

Alarm systems are usually open-loop control systems. A basic alarm system contains two essential components alarm detection and an alarm indicator. Frequently, they are remote control systems, that is, the detector is located remotely from the indicator.

2.2.1 ALARM DETECTORS

Alarm detectors are used to monitor a given situation and provide the information required to decide whether or not an abnormal or dangerous condition exists. The type of detector is determined by the particular application and by the nature of the physical quantity being detected. In a burglar system, a metallic tape is usually placed at entrances to the building. This tape has an electric current passing through it, which causes an electromechanical relay to be actuated. Any intruder entering the building breaks the tape, interrupting the current to the relay. This reenergizes the relay and causes the relay contacts to operate the alarm indicators.

In a petroleum refinery, process alarm systems are used to indicate abnormal or dangerous conditions in many phases of the refinery process. These detectors are used to warn operating personnel when process levels are changing too fast or have exceeded safe limits. They include thermocouple resistance temperature detectors (RTD), temperature sensitive switches, liquid flow detectors and pressure detectors.

2.2.2 ALARM INDICATORS

Alarm indicators are used to translate the information from alarm detectors into a warning signal when a predetermined limit is exceeded. The warning usually is accomplished by means of a visual or an audible signal. These signals can be as common place

as the flashing light and ringing bell that are often found at railroad grade crossing. It can also take the form of a visual indicator or a meter that provides information about pressure, temperature, voltage or some other physical quantity. Alarm indicators may also be by means of an electric printer or cathode-ray tube (CRT) connected to computers [1].

Owing to the very important role of alarm system, their use has become increasing wide spread. Their areas of application include but are by no means restricted to fire/smoke alarms, burglar alarm, and process alarm. For the purposes of this project, emphasis is on the burglar alarm.

A burglar alarm is a system that detects the presence of an intruder and gives an alarm. In the words of Marvin Riemann of the RCA Institutes Inc., “ if the primary aim is to deter intruders, a bell, horn, siren or light is used to give the alarm; if the primary aim is to apprehend intruders, a signal is transmuted by wire to a nearby police station or security office.

An electrical alarm system has circuits with pushbutton switches whose contacts are closed by the closing of doors and windows. When a door or window is opened, the switch contacts open and activate the alarm.

An infrared alarm system uses an infrared beam projected onto a photoelectric cell either directly or by means of mirrors. If an intruder interrupts the invisible infrared beam the break is detected, triggering the alarm. A wide area can be covered when mirrors deflect the beam.

An electronic alarm system has two balanced electronic oscillators connected to an antenna mounted in the area to be protected. The presence of an intruder near the antenna causes the oscillator to become unbalanced because of his body capacitance; the unbalance is detected triggering the alarm.

An ultrasonic alarm system constantly transmits and receives an ultrasonic wave pattern; a movement of an intruder causes the pattern of the received signal to differ from that of the transmitted signal. This difference is detected and used to trigger the alarm [2].

2.3 THE 555 TIMER

The 555 timer is used in this project as a tone generator. It is connected in the astable mode as an oscillator to generate a 1 KHz signal. The 555 timer is a very rugged and versatile chip whose development has come a long way. A brief history of the 555 timer is given below.

The 555 timer IC was designed and invented by Hans R. Camezind who holds other 20 U. S patents for different semiconductor invention. Camezind designed the 555 back in 1970 while employed for the engineering department at Signetics Corporation. The original application was for a timer and oscillator, but was moved well beyond that 555's are used everywhere from toys to consumer electronics and space electronics application these days. Even in 1997, a reference is made by Camezind, "Redesigning the old 555", IEEE spectrum, September 1997. Prior to his Signetics career Camezind worked at PR Mallory's research lab for six years.

The 555 timer IC was first introduced around 1971 by the Signetics Corporation as the SE555/NE555 and was called "The IC Time Machine" and won also the very first and only commercial timer IC available. It provided circuit designers and hobby tinkerers with a relatively cheap, stable and user-friendly integrated circuit for both mono stable and a stable application.

The idea for the 555 came up to accommodate first the old 565 PLL and later the 566. The PLL needed an oscillator to-lock-on to and the oscillator had to be sensitive enough to be insensitive to the large variation of parameters inside the PLL IC. So you would set the

frequency with a resistor and a capacitor, which was it Camezind used the basic principle of this to design his 555 timer. At the time prior to the 555, the oscillation has to be built from the ground up, 23 transistors, 2 zener diodes and 15 resistors. The design for the 555 took a year, from start to prototypes and small production quantities. The whole thing designed by one man, Hans R. Camezind, the one-man design house.

How did the 555 get its name? Signetics had "500" number, and the earlier product worked on by Camezind was the 565, 566 and the 567. It was arbitrarily chosen by signetics Art Fury, the marketing manager, who figured that the circuit was going to sell big then decided to pick the name 555. The first 555's were made both in plastic and metal cases. The 555 has been solidly used and produced for over 30 years still today over 1 billion a year (2003) are manufactured but now most at Samsung in Korea.

Since this device was first made commercially available, a myriad of novel and unique circuit have been developed and presented in several trade, professional and hobby publications.

From the foregoing it is seen that the 555 timer is a versatile and rugged chip. This inform the choice of the IC for the project and hence its incorporation into the design as the main IC.

2.4 THE LIGHT DEPENDENT RESISTOR

The light dependent resistor (LDR) is used in this as a sensor. However it is used here as a dark operated sensor. This means that the circuit only operates when the resistance of the LDR increases as a result of obstruction of light to its surface, thereby increasing the level of darkness around it.

The light dependent resistor also known as the photoresistor is a semi conductive device whose conductivity increases (or whose resistivity decreases) in proportion to the intensity of incident light.

As long as no light is incident upon the device, the light dependent resistor (LDR) has a certain high resistance called the dark resistance, R_d . It is one of the parameters of LDRs and may be as large as $10^4 - 10^7$ ohms. In bright sun light this resistance falls to about 100 ohms.

The associated current flowing through the device is called the dark current. When there is incident radiation with photons having sufficient energy, pairs of mobile carriers are generated (electrons and holes) in it, and its resistance decreases.

The performance of a photo resistor or LDR is usually assessed in terms of the specific sensitivity, that is, the integral sensitivity per volt of applied voltage;

$$S_{sp} = \frac{I}{\Phi V}$$

It is usually several hundred or thousand microamperes per lumen. Photo resistors have a linear V-I characteristic as shown in Fig 2.1 (a) and (b)

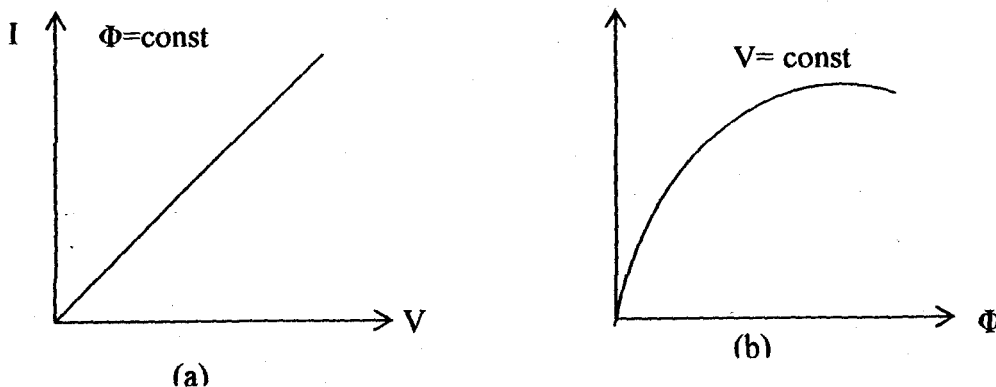

Fig 2.1 V-I characteristic of a photo resistor (LDR)

Semiconductor materials commonly employed in the manufacture of light dependent resistors include; Cadmium sulphide (CdS) and cadmium selenide (CdSe) which are sensitive to visible light. Lead sulphide (PbS) on the other hand is most sensitive to infrared light.

It should however be noted that light dependent resistors have a particular property in that they remember the lighting conditions in which they have been stored. This property is called Hysteresis. The hysteresis effect is most noticeable at low light levels. Storing the LDRs in light prior to use can minimize this memory effect. Light storage reduces equilibrium time to reach steady resistance values.

Common areas of application of the LDR include photographic light meters, security alarms and street lighting controllers.

The circuit symbol for an LDR is shown in fig 2.2

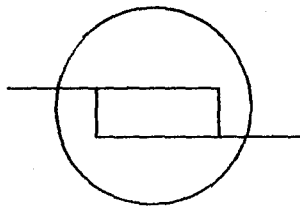

Fig. 2.2: The LDR symbol

CHAPTER THREE

CIRCUIT DESIGN AND ANALYSIS

In order to realize the design and implementation of this project, the project was further divided into functional units or sub circuits. The coupling together of these functional units results in the final circuit.

These functional units include:

- i. The power supply/charging unit
- ii. The Schmitt trigger trip dark detector/switch unit.
- iii. The tone generator unit
- iv. The transmitter/Rf amplifier unit
- v. The speakers and antenna output units

Each of these sub-circuits will be treated one after the other.

3.1 THE POWER SUPPLY/CHARGING UNIT

Most of the electronic devices and circuits require a dc source for their operation. They have the advantage of being portable and ripple free. However, their voltages are low, require frequent replacement and are expensive as compared to conventional dc power supplies. Since the most convenient and economical source of power is the domestic ac supply it is advantageous to convert this alternating voltage (usually 220 Vrms) to dc voltage (usually smaller in value). This process of converting ac voltage into dc voltage is called rectification and is accomplished with the help of a

- i. Transformer
- ii. Rectifier
- iii. Filter

iv. Voltage regulation circuit [3].

This project is powered by a 12v dc source. A 220v ac mains supply is rectified to produce a 12v dc supply. However the circuit also incorporates a charging unit for charging a 12v dc battery, which will provide alternative power to the circuit. In this way, a more efficient means of power is guaranteed and constant power to the circuit is maintained as the battery takes over as soon as the ac power fails in the event of power outage or disconnection by a burglar or intruder.

3.1.1 TRANSFORMER

A transformer is a static or stationary piece of apparatus by means of which electric power on one circuit is transformed into electric power of the same frequency in another circuit. It can raise or lower the voltage in a circuit but with a corresponding decrease or increases in current. The transformer operates on the principle of electromagnetic induction however mutual induction between two circuits linked by a common magnetic flux. Thus, the primary and secondary section of a transformer are electrically isolated from each other but are magnetically coupled.

In construction, transformers are generally of two types:

- i. Core type
- ii. Shell type

In the core type transformer, the windings surround a considerable part of the core while the shell type on the other hand has the core surrounding a considerable portion of the windings [3]. Each of these two types of transformers could be a step up transformer or a step down transformer. A step up transformer transforms a lower primary voltage into a higher secondary voltage while a step down transformer transforms a higher primary voltage into a lower

secondary voltage. For the purpose of this project, a step down transformer shall be employed to transform the 240v ac supply into a 12v ac supply. This is achieved by means of the emf equation of a transformer given by.

$$\frac{E_2}{E_1} = \frac{N_2}{N_1} = K$$

Where

E_1 = induced emf in the primary winding

E_2 = induced emf in the secondary winding

N_1 = number of turns in primary

N_2 = number of turns in secondary

K = voltage transformer ratio

If $N_2 > N_1$ i.e. $K > 1$, then transformer is a step up transformer

If $N_2 < N_1$ i.e. $K < 1$, then transformer is a step down transformer [3]

A simple circuit to illustrate the transformer action is shown below:

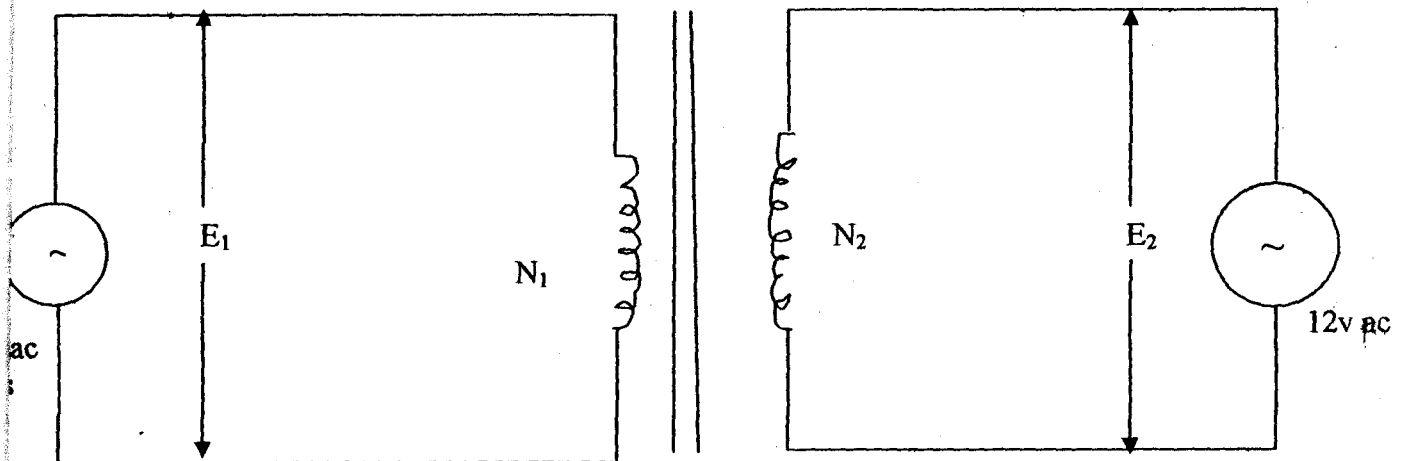

Fig. 3.1 Step Down Transformer

Since the ac voltage has been stepped down, a rectifier circuit is employed to convert the 12v ac to a 12v dc supply.

3.1.2 RECTIFIER

The process of obtaining unidirectional currents and voltage from alternating currents and voltages is termed rectification. Rectification is achieved by means of circuit called rectifiers. The principal device in rectifier is the diode, which allows current to pass in one direction while opposing the flow of current in the opposite direction [5]

There are two types of rectification viz.

- i. Half wave rectification
- ii. Full wave rectification

The half wave rectification uses (1) diode and allows currents to flow during one half cycle of the sinusoidal input voltage, hence the name half wave rectifier.

The full wave rectifier can be achieved using two (2) diodes as in the simple full wave rectifier or using four (4) diodes as in the bridge rectifier circuit. For the purposes of this project, the bridge rectifier shall be utilized for rectification of the 12v ac to the 12v dc supply. Figure 3.2 below shows a full wave bridge rectifier circuit.

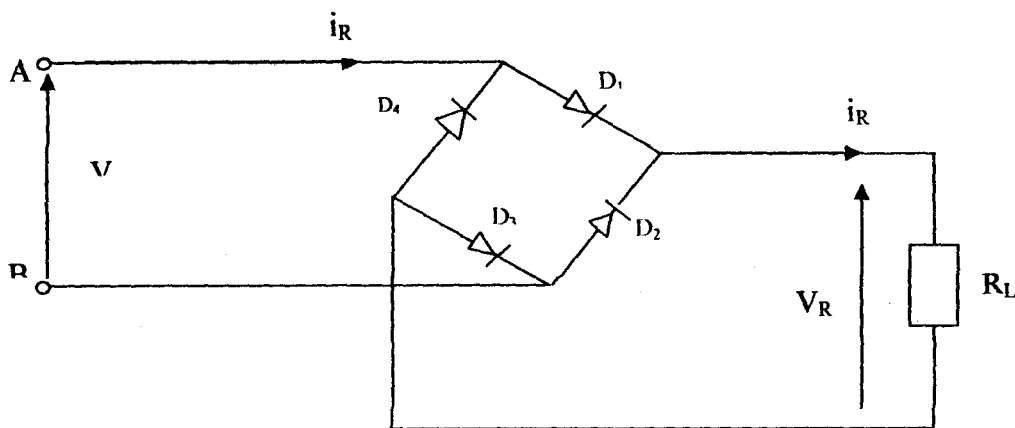

Fig 3.2 Full Wave Bridge Rectifier

The equivalent bridge rectifier showing the active circuit during each cycle is represented below in fig. 3.3(a) and (b)

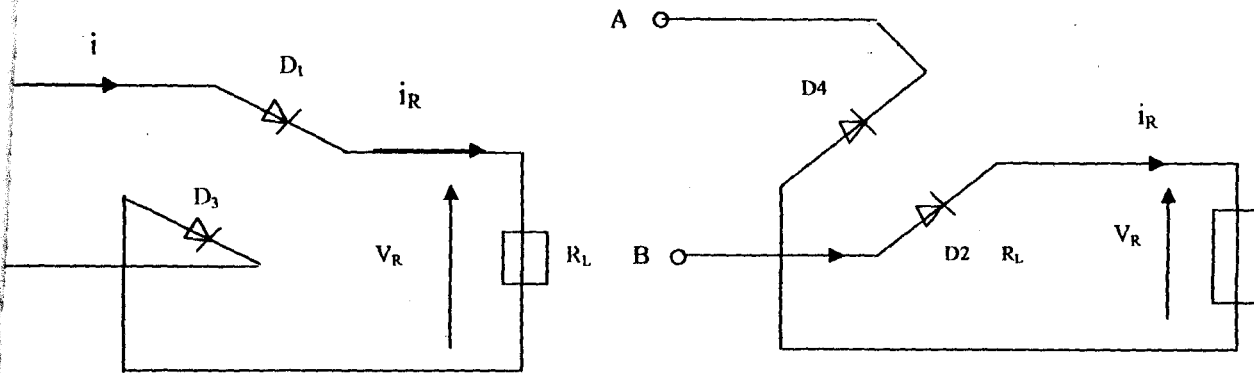

Fig 3.3 (a) Equivalent circuit of positive half cycle of bridge rectifier

(b) Equivalent circuit of negative half cycle of bridge rectifier

The waveform of the input into the rectifier and output from the rectifier are shown in the diagram below.

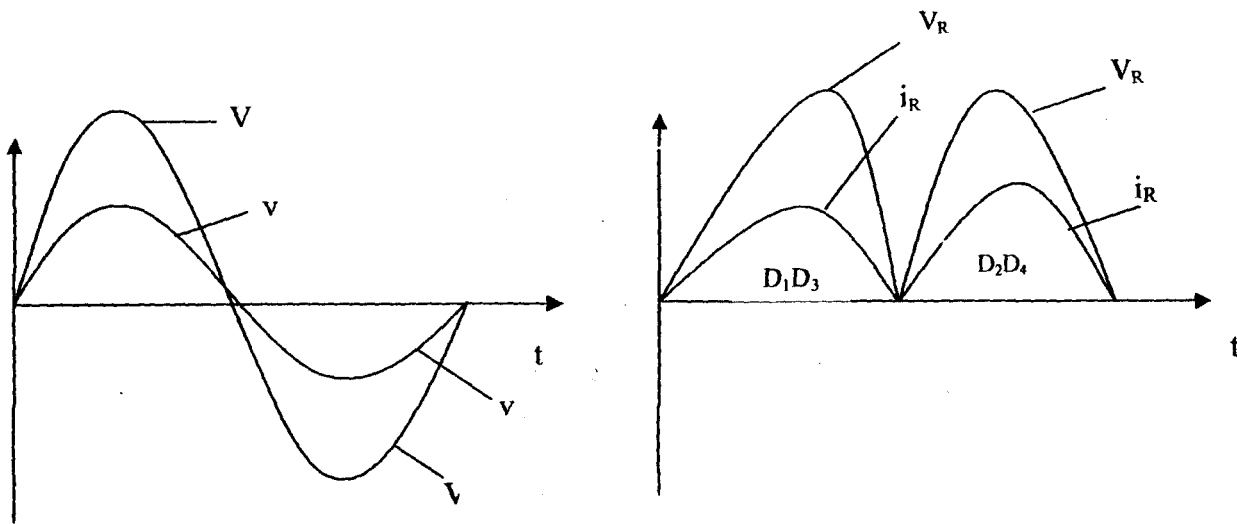

Fig. 3.4 (a) Sinusoidal input voltage

(b) output voltage from the bridge rectifier

Diodes D_1 and D_3 conduct during the positive half cycle while diodes D_2 and D_4 conduct during the negative half cycle. This results in a unidirectional positive voltage output with a lot of ac ripples alongside [5].

The instantaneous input voltage V , is given as

$$V = V_m \sin \omega t$$

The instantaneous current I , is given as

$$i = \frac{V}{R_L}$$

$$(V_m/R_L) \sin \omega t: 0 \leq \omega t \leq 2\pi$$

Since, rectification is aimed at providing a dc current the effective dc current is the average value of the waveform, then,

$$I_{dc} = \frac{1}{2\pi} \int_0^{2\pi} i(\omega t) d(\omega t)$$

This can be written as

$$I_{dc} = \frac{1}{2\pi} \left\{ \int_0^{\pi} \frac{V_m \sin \omega t d(\omega t)}{R_L} + \int_{\pi}^{2\pi} \frac{V_m \sin \omega t d(\omega t)}{R_L} \right\}$$

$$I_{dc} = \frac{V_m}{2\pi R_L} \left\{ \int_0^{\pi} \frac{V_m \sin \omega t d(\omega t)}{R_L} + \left| \int_{\pi}^{2\pi} \frac{V_m \sin \omega t d(\omega t)}{R_L} \right| \right\}$$

$$I_{dc} = \frac{V_m}{2\pi R_L} \left\{ \left[-\cos wt \right]_0^\pi + \left/ \left[-\cos wt \right]_{\pi}^{2\pi} \right/ \right\}$$

$$I_{dc} = \frac{V_m}{2\pi R_L} \left\{ (1 + 1) + / (-1 - (-1)) / \right\}$$

$$I_{dc} = \frac{4V_m}{2\pi R_L}$$

$$I_{dc} = \frac{2V_m}{\pi R_L}$$

$$I_{dc} = \frac{2I_m}{\pi}$$

This value of I_{dc} is depicted in fig. 3.5 below

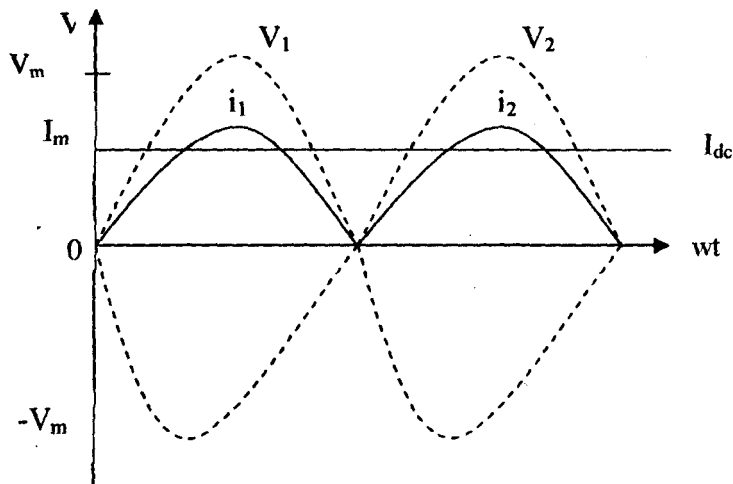

Fig. 3.5 Waveform showing direct current I_{dc}

3.1.2.1 RIPPLE FACTOR

Ripple factor, r , is a measure of effectiveness of rectification in a power supply often the output current of a rectifier certain ac components (harmonics) along the dc components.

Ripple factor r is expressed as

$$r = \frac{\text{rms value of ac components}}{\text{dc components}}$$

$$r = \frac{I_{ac}}{I_{dc}} = \frac{V_{ac}}{V_{dc}}$$

The power dissipated in the load resistance defines the rms value of current. Also the total power is the sum of the power dissipated by the dc and ac components, so that.

$$I_{rms}^2 R_L = I_{dc}^2 R_L + I_{ac}^2 R_L$$

$$I_{ac}^2 = I_{rms}^2 - I_{dc}^2$$

$$r = \frac{I_{ac}}{I_{dc}}$$

$$r = \frac{\sqrt{I_{rms}^2 - I_{dc}^2}}{I_{dc}}$$

$$r = \sqrt{\left(\frac{I_{rms}}{I_{dc}}\right)^2 - 1}$$

The lower the value of r , the more effective is the circuit conversion or rectification

A smoothing capacitor is then employed to filter out the ac ripple.

3.1.3 FILTER

The filtering action is achieved by means of a suitable capacitors connected across the rectifier and in parallel with the load R_L . This type of filter is known as capacitor input filter or shunt capacitor input filter.

This filter circuit depends for its operation on the property of a capacitor to charge up (i.e. store energy) during conducting half – cycle and to discharge (i.e. deliver energy) during the non-conducting half-cycle. In simple words, capacitor opposes any change in voltage. When connected across a pulsating dc voltage, it tends to smoothen out or filter out the voltage pulsation (or ripples). The filtering action of the simple capacitor filter when used in a full wave rectifier can be understood with the help of the figure of 3.6 and 3.7 below [3]

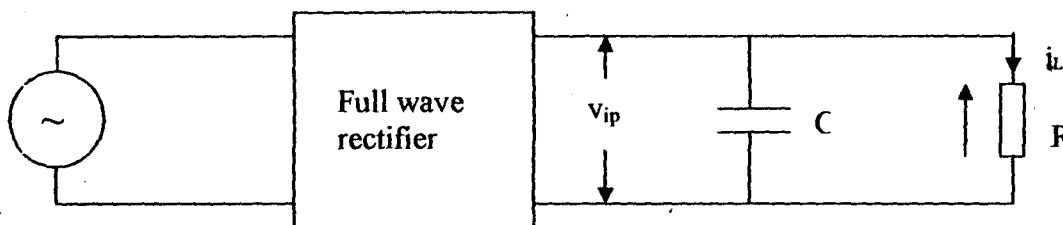

Fig. 3.6: Filter circuit

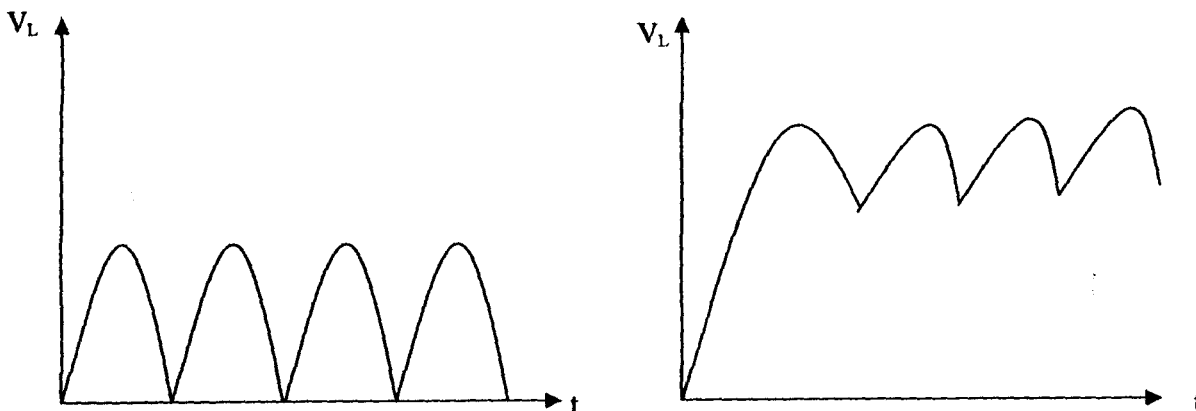

Fig. 3.7 (a) without filter

(b) with filter

As can be seen from the waveform, the output from the shunt capacitor filter though smoothed still has some ac ripple. In practice the dc voltage from the rectifier filter does fluctuate. The fluctuation arises from fluctuation in amplitude of supply voltage V_{in} such a dc power supply is called unregulated power supply because output voltage changes with changes

in load or input voltage. Regulated power supply can be achieved by using a voltage regulator circuit.

3.1.4 REGULATOR

A regulator is an electronic control circuit, which is capable of providing a nearly constant dc output voltage even when there are variations in load or input voltage. A source of regulated dc power is essential for all communication, instrumentation, computer or any other electronic system [3].

3.1.4.1 THE LM317T 3 – PIN ADJUSTABLE REGULATION

The LM317T adjustable is a 3 –pin terminal positive voltage regulator capable of supplying current in excess of 1.5A over a 1.2 to 3.7v output voltage. The LM317T regulator is exceptionally easy to be use and requires only two external resistors to set the output voltage. The LM317T further offer better line and load regulation than standard fixed regulator. The regulator is package in a standard TO220 standard transistor package, which is easily mounted and handled. In addition to higher performance than fixed regulators, the LM317T offers a full overload protection, and safe operating area (SOA) protection. All overload protection circuitry remains fully functional even with the adjustment terminal disconnected.

Normally, an LM317T requires no capacitor unless; the regulator is situated more than 6 inches from the input filter capacitors in which case an input bypass is needed. An optimal output capacitor can be added to improve transient response, and the adjustment terminal can be by passed to achieve very high ripple rejection ratios difficult to achieve with standard 3 – terminal regulator like the 78xx, 79xx, 723 etc [10]

3.1.4.1.1 APPLICATION HINTS FOR LM317T

The regulator develops a normal 1.25v reference voltage, V_{REF} , between the output and adjustment terminal. The reference voltage is impressed across program resistor R_1 , and since the voltage is constant, a constant current I , flows through the output set resistor R_2 , giving an output voltage of:

$$V_{out} = V_{REF} (1 + R_2/R_1) + I_{adj}R_2$$

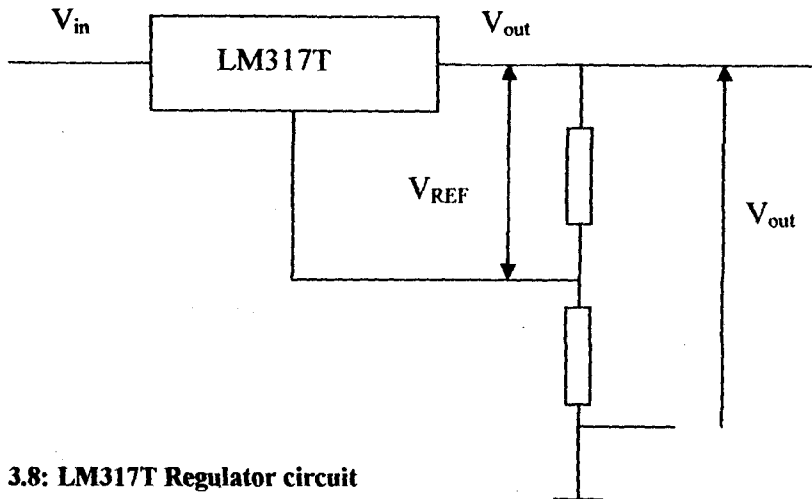

Fig. 3.8: LM317T Regulator circuit

The LM317T is designed to minimize I_{adj} and make it very constant with line and load changes. The LM317T was configured as a constant current, constant – voltage regulator to charge two 6v 4.5Ah lead acid batteries that provide system power back up.

At the beginning of the charge cycle when the battery voltage is less than that high enough to source 0.65v into the base of the 2SC1815GR, Q1 is off allowing the adjustable voltage regulation to operate as a constant current source. The regulator therefore forces a constant 1.25v across R_{Lim} , thus generating a constant current of:

$$I_{Lim} = (1.25v/R_{Lim}) A$$

R_{Lim} was chosen as 1 Ω to produce a charging current of 1.25A

As the batteries charge, their voltages rise and is passed at the output of the 12v zener diode. Once the battery voltage reaches (that present by the 20KΩ terminal resistor and V_z plus 0.6v needed to turn on Q_1 . Q_1 starts controlling the ADJ pin of the LM317T, which then starts to regulate the voltage across the battery, and the constant voltage portion of the charging cycle starts. Once the charger is in the constant voltage mode, the charger maintains a regulated voltage across the battery and the charging current is dependent on the start of charge of the battery. As the cells approach a fully charged condition, the charge current falls to a very low value.

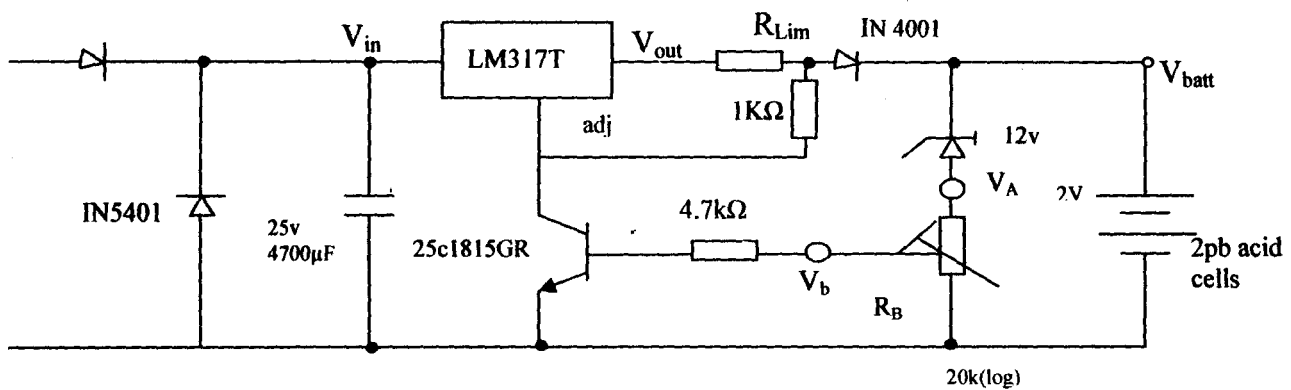

Fig 3.9: Charging unit

The circuit shows the LM317T configured to generate a constant voltage of 12.6v (minimum) and $(V_{in} - 1.25)$ V (maximum) across the two lead acid batteries

The output voltage is determined from the expression:

$$V_b = 0.6 = \frac{V_A \times R_B}{R_A + R_B} \dots\dots\dots i$$

$$\text{But } V_A = (V_{batt} - V_2) \\ = (V_{batt} - 12) V \dots\dots\dots ii$$

$$0.6R_A + 0.6R_B = V_A \times R_B \dots\dots\dots iii$$

Substituting equation (ii) into (iii)

$$0.6R_A + 0.6R_B = (V_{batt} - 12) \times R_B \dots\dots\dots (iv)$$

$$0.6(R_A + R_B) = V_{batt} \times R_B - 12R_B \dots\dots\dots (v)$$

$$V_{batt} \times R_B = 0.6(R_A + 0.6R_B) + 12R_B$$

$$V_{batt} = \frac{0.6R_A + 0.6R_B + 12R_B}{R_B}$$

$$V_{batt} = \frac{0.6R_A + 12.6R_B}{R_B}$$

$$V_{batt} = 0.6(R_A/R_B) + 12.6$$

Thus the battery voltage is programmable for any chosen value of R_A and R_B . The IN4001 diode is used to prevent the battery current from flowing through the LM317T regulator from the output to the input when the dc input voltage is removed.

The 25v 4700 μ f by pan capacitor is used to stabilize the operation of the charging subsystem. The two IN5401 diodes are used to prevent wrong battery connection. A LED indicator connected across the circuit comes on to indicate the presence of power when the switch is in the ON position and goes off to indicate the absence of power when the switch moves to the OFF position.

3.2 THE SCHMITT TRIGGER TRIP DARK DETECTOR/SWITCH CIRCUIT

The input stage of the circuit is built on a two – transistor positive feed back Schmitt trigger circuit that provides a snap action; on/off activation of the modulation and radio frequency (RF) transmitter. The basic arrangement of the Schmitt trigger circuit is shown in the figure of 3.10 below.

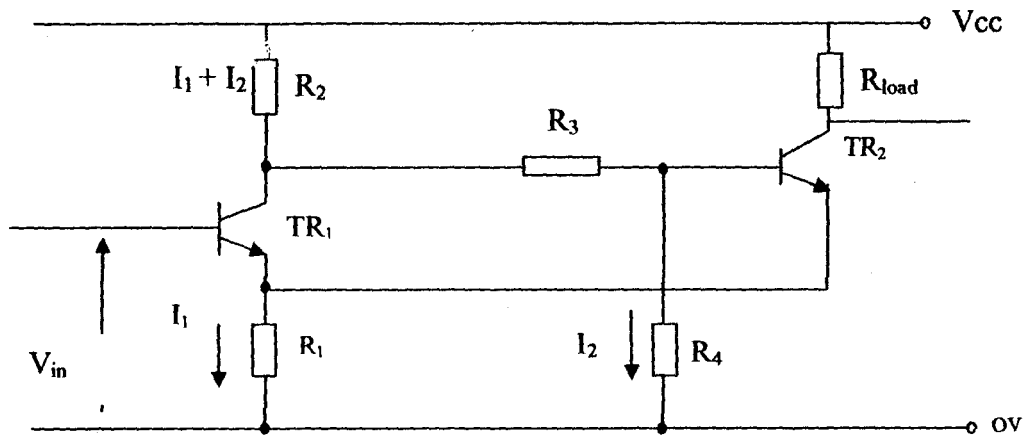

Fig. 3.10 Schmitt trigger circuit

Two voltage levels are important in the overall operation and design consideration of the Schmitt trigger: the first is V_{on} , the voltage applied to the base of TR_1 which causes it to switch to the on state; the second voltage level is V_{off} , the voltage at which transistor TR_1 switches off.

For practical purposes, hysteresis is needed in circuits like this to prevent oscillation/instability around a mean fixed control voltage and this hysteresis is the difference between V_{on} and V_{off} . Hysteresis means “lagging behind” and in a schmitt trigger circuit V_{off} lags V_{on} as shown in fig. 3.11 below.

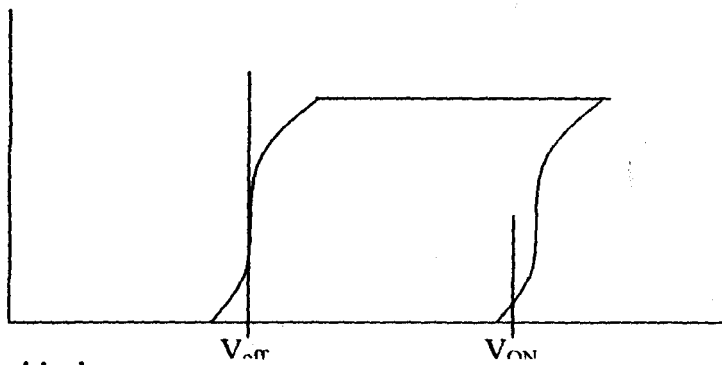

Fig. 3.11 Hysteresis loop

Hysteresis makes switching circuits considerably more useful in control systems as it is responsible for the sharp action effect.

Suppose TR1 is off and TR2 is on. Assume that the base current of TR2 is small compared with the current flowing through the voltage divider chain made up of R₂, R₃ and R₄. it can be seen that the base voltage of TR₂ is given by.

$$V_{b2} = V_{cc} \times \frac{R_4}{R_2 + R_3 + R_4}$$

Neglecting the small base emitter voltage of TR2 (0.64v for the transistor used, 25C1815GR), this voltage, V_{b2} is the voltage at the emitter of TR2, and hence at the emitter of TR1, since the two transistors are emitter – coupled. Again neglecting the small voltage across the base emitter of TR1 when this transistor switches on, the equation also gives the voltage required to switch on TR1. If the input voltage is greater than V_{on}, positive feedback will drive TR1 further ON and TR2 further OFF.

It is not likely that V_{off} will equal V_{on} since quite a sudden change in the circuit has caused TR1 to switch on and TR2 to switch off. However, suppose the base – emitter voltage of TR1 is reduced so that TR2 is just about to switch on. Since TR1 is already on and TR2 is just about to come on, the voltages at the bases of both transistors are close to their respective emitter voltage since they are connected together. Thus, the emitter and base terminals of these transistors are close to the voltage V_{off} then:

$$I_1 = V_{off}/R_1 \text{ and}$$

$$I_2 = V_{off}/R_4$$

And the voltage drop across R₂ and R₃ is given by

$$V_{cc} - V_{off} = (I_1 + I_2) R_2 + I_2 R_3$$

Substituting the values of I₁ and I₂ given above, the equation for V_{off} is obtained thus.

$$V_{off} = \frac{V_{cc}}{(1 + R_2/R_1 + R_2/R_4 + R_3/R_4)}$$

$$\text{Hysteresis} = V_{on} - V_{off}$$

For the circuit shown earlier, R_2 was chosen as $2.2K\Omega$ and $R_4 = 1K\Omega$, and V_{cc} fixed by a 5v regulator at approximately 4.72v. Calculating for the values of V_{on} and V_{off} yielded

$$V_{on} = \frac{4.72 \times 2200}{2200 + 2200 + 2200} = 1.5733v$$

$$V_{off} = \frac{4.72}{(1 + 2200/2200) + (2200/2200) + (2200/2200)}$$

$$= 4.72/2 = 1.18v$$

$$V_{\text{hysteresis}} = (1.5733 - 1.18) V = 0.393v$$

Considering the complete schematic of the RF alarm circuit, the base voltage of TR1 is held at 4.7 1v by the LDR 150K Ω potential divider network.

In this arrangement, the LDR is constantly illuminated; keeping its resistance very low and TR1 on since TR1's base voltage is now very close to 5v. With TR1 on, TR2 is off and consequently TR₃ is off since its base is almost at 12v. This cut off TR₃ and no current flows through TR₃ into the load. In this state, the transmitter, tone generator which is provided by the 555 timer and the modulator are powered down.

When the LDR is covered, i.e. the source of illumination is broken or the reed switch is opened, TR1's base voltage is removed, and it held off by the voltage at its emitter TR2 now conducts and pulls its collector very close to ground pulling TR3 into conduction. Since $V_a \gg V_b$ for TR₃ current flows through its CE junction into the connected loads and the erstwhile dead circuit is now powered on.

A switch is used as a latching device to control the mode of operation of the alarm circuit. A 7805 regulator is employed to give a 5V supply to Schmitt trigger circuit.

The Schmitt trigger can be made to operate in one of two modes; mode 1 and mode 2.

In mode 1 which corresponds to the open condition of the mode switch i.e. every designed-for condition when the LDR goes dark or the reed switch is opened; the oscillation/transmitter is powered briefly. This means that if the conditions are removed i.e. The LDR is illuminated and/or the reed switch is closed, the circuit stops generating an alarm tone. In this mode, the circuit can detect how many times the door has been opened, or how many times the LDR has been cut off from the source of illumination.

In mode 2 operation, the circuit acts as a transistor based thyristor in that once it is activated, it stays activated, whether the triggering condition are removed or not. This is the full alarm mode. Once latched, the oscillation/ transmitter sends out a 1 KHz tone on 92MHz frequency, which clearly lies in the FM (frequency modulation) spectrum or band. The tone generator also drives a loud speaker to generate an audible alert. The circuit can be disabled by switching over to mode 1 momentarily before switching back to mode 2.

Note, however, that the circuit will be activated again if the designed for condition are met i.e. door open or LDR cut off from its source of illumination.

3.3 1KHZ TONE GENERATOR

The 1 KHz tone is generated by means of a 555 timers connected in astable mode. The astable multi vibrator generates a continuous stream of rectangular off-on pulses that switch between two voltage levels. The frequency of the pulses and their duty cycle are dependent upon the RC network value. Thus, an astable multivibrator simply behaves as an oscillator [9] the tone generated from the astable multi vibrator serves as modulating signal which modulates the frequency of the carrier wave.

The figure below shows the 555 connected as an astable multivibrator. Both the trigger and threshold inputs (pin 2 and 6) to the two comparators are connected together to the external capacitor.

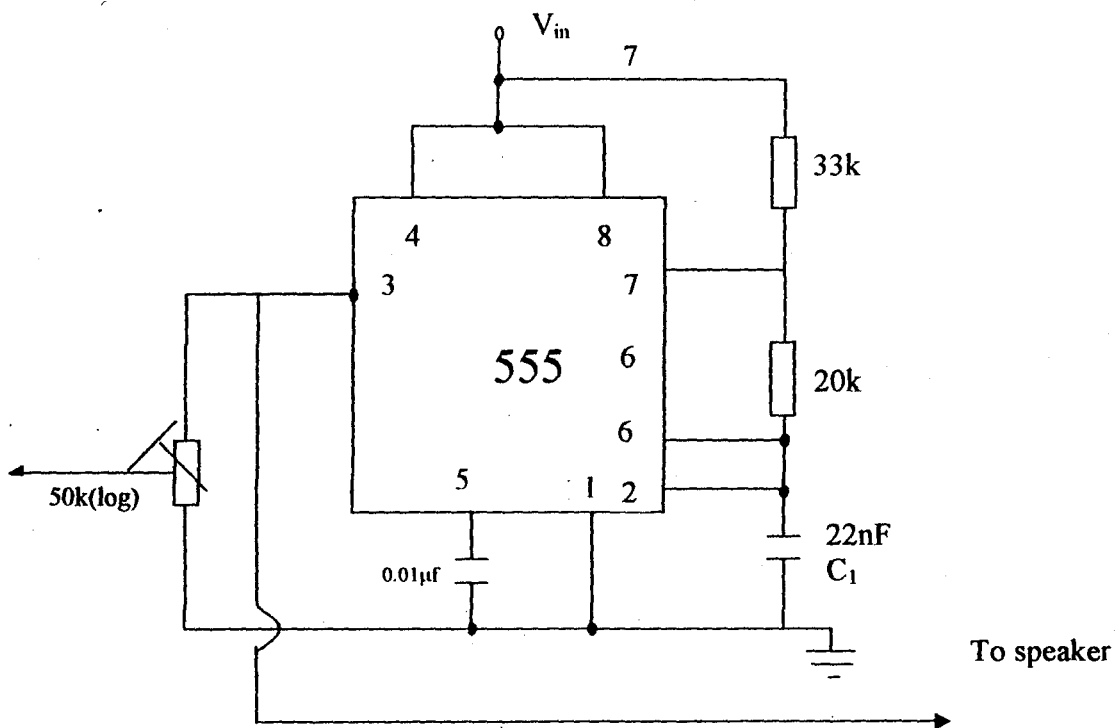

Fig. 3.12 Tone generator

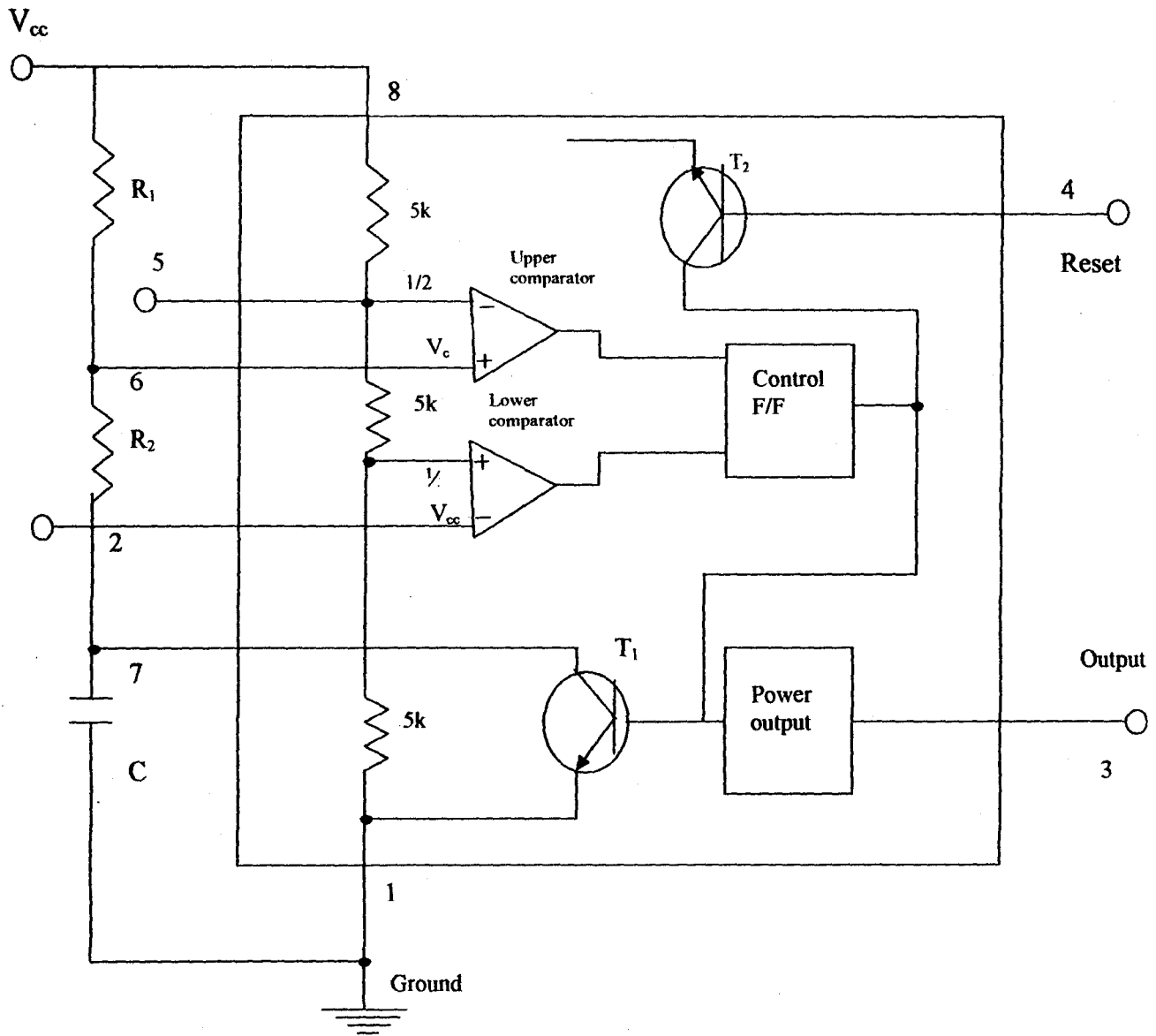

Fig. 3.13: Internal circuitry of a 555 timer

The capacitor charges towards the supply voltage through the two resistors R1 and R2. The discharge pin (7) connected to the internal transistor is connected to the junction of these two resistors.

When power is first applied to the circuit, the capacitor will be uncharged; therefore, both the trigger and threshold inputs will be near zero volts. The lower comparator sets the control flip-flop causing the output to switch high. That also turns off transistor TI (internal transistor of the 555). That allows the capacitors C1 to begin charging through R1 and R2. As soon as the charge on the capacitor reaches $\frac{2}{3}$ of the supply voltage, the upper comparator will trigger causing the flip-flop to reset. This causes the output to switch low. Transistor TI also conducts. The effect of T1 conducting causes resistor R2 to be connected across the external capacitor. Resistor R2 is effectively connected to the ground through internal transistor TI. The result of that is that the capacitor now begins to discharge through R2.

As soon as the voltage across the capacitor reaches $\frac{1}{3}$ of the supply voltage, the lower comparator is triggered. That again causes the control flip-flop to set and the output to go high. Transistor T1 cuts off and again the capacitor begins to charge. That cycle continues to repeat with the capacitor alternately charging and discharging, as the comparators cause the flip-flop to be repeatedly set and reset. [9]

The charging and discharging action of a capacitor is further explained in the next section.

3.3.1 EQUIVALENT CHARGING AND DISCHARGING ACTION OF THE 555 TIMER CAPACITOR

Consider the circuit shown below in fig. 3.14

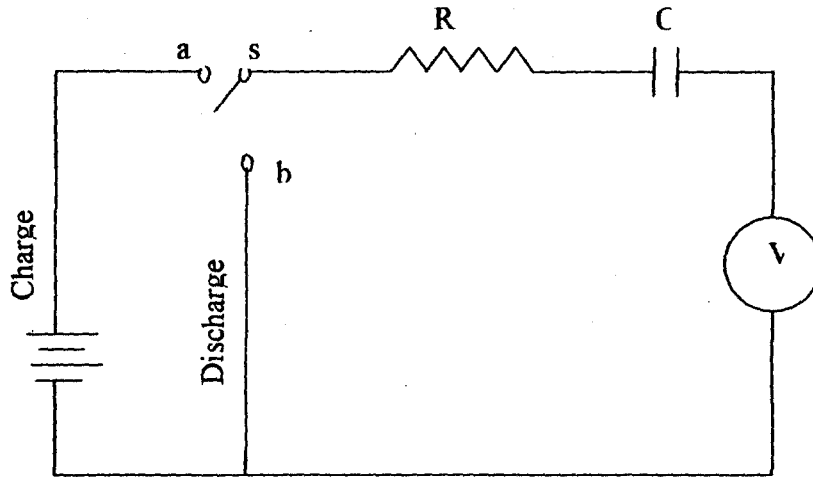

Fig. 3.14 Capacitor charging/ discharging circuit

Capacitor C is charged through a high resistor R from a battery of V volts. S is a single pole double throw (SPDT) switch used to either charge or discharge the capacitor. The voltage across C can be measured by a suitable voltmeter [3]

3.3.1.1 DURING CHARGING

During charging, the switch, s, is at position a and as such the circuit becomes:

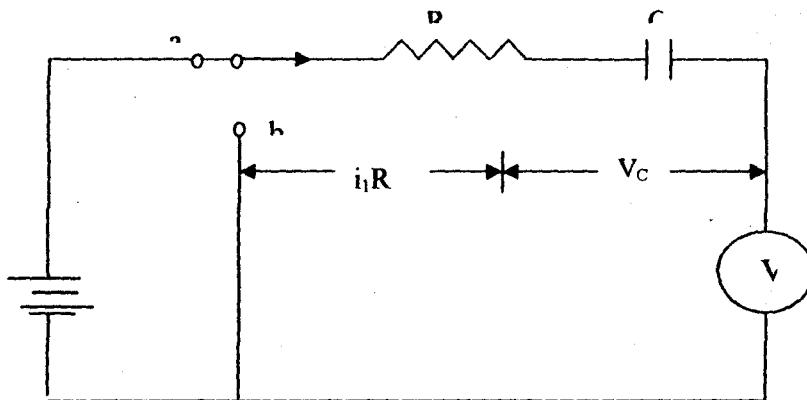

Fig. 3.15 Circuit showing the charging of the capacitor

The applied voltage v is always equal to the sum of (i) resistor drop ($i_c R$) and (ii) voltage across V_c

$$V = i_c R + V_c \dots\dots\dots i$$

Now $i_c = dq/dt = d/dt (CV_c) = Cdv_c/dt$

$$\therefore V = V_c + CR \, dV_c/dt \dots\dots\dots ii$$

Or $-dv_c/V - V_c = -dt/CR$

Integrating both sides, we get

$$\int -dV_c/(V - V_c) = -1/CR \int dt$$

$$\therefore \log_e (V - V_c) = -t/CR + K \dots\dots\dots iii$$

Where

K is the constant of integration whose value can be found from initial known condition. we know that at the start of charging when

$$t = 0, V_c = 0$$

Substituting these values in (iii), we get

$$\log_e V = K$$

Hence (iii) becomes

$$\log_e (V - V_c) = -t/CR + \log_e V$$

or $\log_e V - V_c = -t/CR = -1/\lambda$

Where $\lambda = CR =$ time constant

$$\therefore V - V_c/V = e^{-t/\lambda} \quad \text{or} \quad V_c = V(1 - e^{-t/\lambda}) \dots\dots\dots iv$$

Now $V_c = q/c$ and $V = Q/C$

(iv) Now becomes

$$q/c = Q/C (1 - e^{-t/\lambda}) \quad \therefore q = Q(1 - e^{-t/\lambda}) \dots\dots\dots v$$

Differentiating both sides of (v), we get

$$\begin{aligned} dq/dt = i_c &= Q d/dt (1 - e^{-t/\lambda}) = Q(1/\lambda e^{-t/\lambda}) \\ &= Q/\lambda e^{-t/\lambda} = CV/CR e^{-t/\lambda} \quad (Q = CV \text{ and } \lambda = CR) \end{aligned}$$

$$\therefore i_c = V/R \cdot e^{-t/\lambda} \quad \text{or } i_c = I_0 e^{-t/\lambda} \dots\dots\dots vi$$

Where I_0 is the maximum current = V/R [3]

3.3.1.2 TIME CONSTANT

Just at the start of charging, p.d across capacitor is zero, hence from (v) putting $V_c = 0$, we get

$$V = CR dv_c/dt$$

Initial use of voltage across capacitor is

$$(dV_c/dt) \text{ at } t = 0 = V/CR = V/\lambda \text{ volt/second}$$

If this rate of rise is maintained, then time taken to reach voltage V would have been

$$\frac{V}{V/CR} = CR$$

This is known as time constant (λ) of the circuit. Hence, time constant of an R-C is defined as the time during which voltage across capacitor would have reached its maximum value V had it maintained its initial rate of rise.

In equation (iv) if $t = \lambda$, then

$$\begin{aligned} V_c &= V (1 - e^{-t/\lambda}) = V (1 - e^{-1}) = V (1 - 1/e) \\ &= V (1 - 1/2.718) = 0.632v \approx 2/3 V \end{aligned}$$

Hence, time constant may be defined as the time during which capacitor voltage (or current) actually uses to 0.632 of its final steady value; since from (vi), at $t = \lambda$

$$I_c = I_0 e^{-1} = I_0/2.718 = 0.37I_0 \text{ [3]}$$

3.3.1.3 DURING DISCHARGE

During discharge the switch, s, moves to position is as shown in the circuit below in fig

3.16

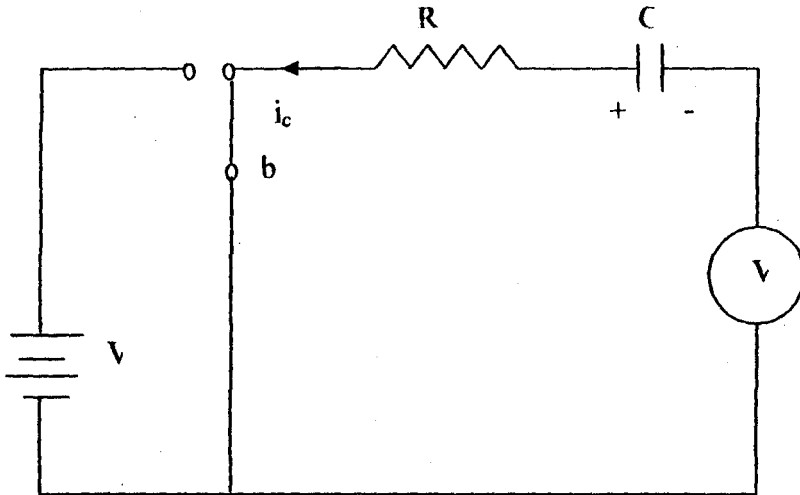

Fig 3.16 circuit showing the discharging of a capacitor

Since the battery is cut off from the circuit, therefore, by putting

$V = 0$ in (ii) we get

$$0 = CR \frac{dv_c}{dt} + V_c = -CR \frac{dv_c}{dt} \quad (\because i_c = -C \frac{dV}{dt})$$

$$\frac{dv_c}{V_c} = - \frac{dt}{CR}$$

Integrating both side we

$$\int \frac{dV_c}{V_c} = - \frac{1}{CR} \int dt$$

$$\therefore \log_e V_c = - \frac{t}{CR} + K \dots \dots \dots (vii)$$

At the start of discharge, when $t = 0$

$$\log_e V_c = 0 + K \quad \text{or} \quad \log_e V_c = K$$

But remember that $t = 0$,

$V_c = V$ (instantaneous value of the applied voltage)

So that

$$\log_e V_c = \log_e V = K$$

Putting this value into (vii) we obtain,

$$\log_e V_c = -t/CR + \log_e V$$

$$CR = \lambda,$$

$$\rightarrow \log_e V_c = -t/\lambda + \log_e V$$

$$\text{Or } \log_e V_c - \log_e V = -t/\lambda$$

$$\text{Log}_e V_c/V = -t/\lambda$$

$$\text{Or } V_c/V = e^{-t/\lambda}$$

$$\therefore V_c = V e^{-t/\lambda} \dots\dots\dots (viii)$$

Similarly, $q = Q e^{-t/\lambda}$ and $i_c = -I_0 e^{-t/\lambda}$

At $t = \lambda$, V_c becomes

$$V_c = V e^{-\lambda/\lambda} = V e^{-1}$$

$$V (1/2.718) = 0.368V [3]$$

Hence, time constant may also be defined as the time during which the capacitor voltage or current falls to 0.368 of its final steady value.

The resulting output is a continuous stream of the rectangular pulses as depicted in the figure of 3.17 below.

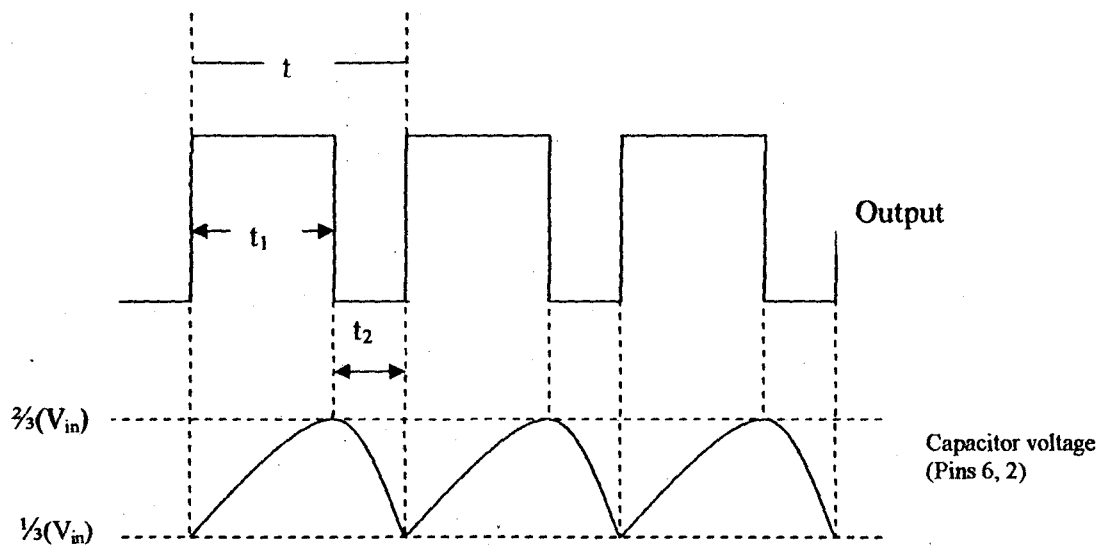

Fig. 3.17 Output waveform of an astable circuit

The frequency of operation of the astable circuit is dependent upon the values of R1, R2 and C1. From the manufacturer's data sheet, the frequency can be calculated with the formula:

$$f = \frac{1.49}{(R_1 + 2R_2) C_1} \quad [10]$$

From the circuit this gives

$$\begin{aligned}
 f &= \frac{1.49}{(33 \times 10^3 + 2 \times 20 \times 10^3) \times 22 \times 10^{-9}} \\
 &= \frac{1.49}{1.606 \times 10^{-3}} \\
 &927.77\text{Hz} \approx 1 \text{ KHz}
 \end{aligned}$$

The above frequency approximates to 1 KHz taking into account the tolerance values of the resistors.

It can be seen that the voltage values at the time constants during charging of the capacitor C1 of the 555 timer approximates respectively to the voltage values at the time constant during charging and discharging.

$$\text{Hence, } 2/3 V_{in} = V (1 - e^{-t/\lambda})$$

$$\text{and } 1/3 V_{in} = V e^{-t/\lambda}$$

The pulse is on for t_1 seconds and then off for t_2 seconds. The total period t is $t_1 + t_2$. The time interval is related to the frequency by the familiar relationship.

$$f = 1/t \quad \text{or } t = 1/f$$

The time interval for the on and off portions of the output depend upon the values of R_1 and R_2 .

The ratio of time duration when the output pulse is high to the total period is known as the duty – cycle. The duty – cycle can be calculated with the formula.

$$D = t_1/t = (R_1 + R_2)/R_1 + 2R_2$$

From the circuit

$$D = \frac{(30 + 20) K}{(30 + 2 \times 20) K} = \frac{50}{70} = 0.714$$
$$= 71.4\%$$

A duty – cycle of 71.4% means that the output pulse is on or high for 71.4% of the total period.

The duty –cycle can be adjusted by varying the values of R_1 and R_2 .

Studies have shown that the normal human ear is most sensitive to sound pressure vibrating at frequencies between 1 KHz – 3 KHz. Hence choice of 1KHz as the modulating tone [8]

3.4 THE TRANSMITTER/RF AMPLIFIER

This project work incorporates an FM transmitter for the purpose of transmitting or radiating the alarm signal via radio wave.

Frequency modulation (FM) is a system in which the amplitude of the modulation carrier is kept constant, while its frequency and rate of change are varied by the modulating signal [6]

The amount of change in frequency is determined by the amplitude of the modulating signal whereas the rate of change is determined by the frequency of the modulating signal [3]

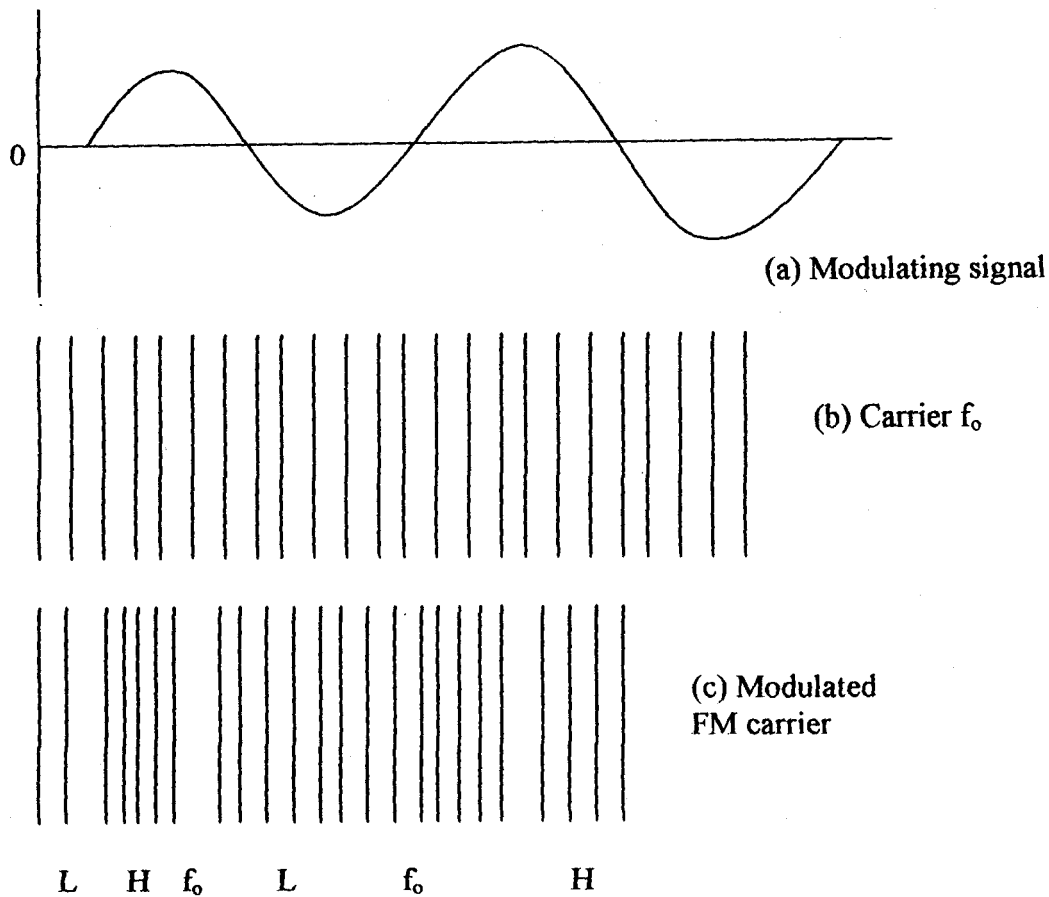

Fig. 3.18 Waveform of FM modulation

As shown above, in an FM carrier, information or (intelligence) is carried as variations in its frequency. Frequency of the modulated carrier increases as the signal amplitude decreases but decreases as the signal amplitude increases but decreases as the signal amplitude decreases. It is at its highest point when the signal amplitude is at its maximum positive value and is at its lowest

frequency when signal amplitude has maximum negative value. When signal amplitude is zero, the carrier frequency is at its normal frequency to (also called resting or centre frequency). This is the allotted frequency of the transmitter. In simple words, it is the carrier frequency on which a station is allowed to broadcast. [3]

3.4.1 MATHEMATICAL EXPRESSION FOR FM WAVE

The unmodulated carrier is given by $e_c = A \sin 2\pi f_o t$

The modulating signal frequency is given by $e_m = B \sin 2\pi f_m t$

The modulated carrier frequency f swings around the resting frequency f_o thus,

$$f = f_o + \Delta f \cdot \sin 2\pi f_m t$$

Hence, equation for the frequency modulated wave becomes

$$\begin{aligned} e &= A \sin 2\pi f t = A \sin [2\pi (f_o + \Delta f \cdot \sin 2\pi f_m t) t] \\ &= A \sin (2\pi f_o t + \Delta f / f_m \cos 2\pi f_m t) \\ &= A \sin (2\pi f_o t + m_f \cos 2\pi f_m t) \quad [3] \end{aligned}$$

Where m_f called the modulation index is given as

$$m_f = \frac{\text{frequency deviation}}{\text{modulation frequency}} = \frac{\Delta f}{f_m}$$

3.4.2 ANALYSIS OF THE TRANSMITTER

The FM transmitter is designed on the basic principle upon which the operations of all direct frequency modulators are based as shown in the figures below:

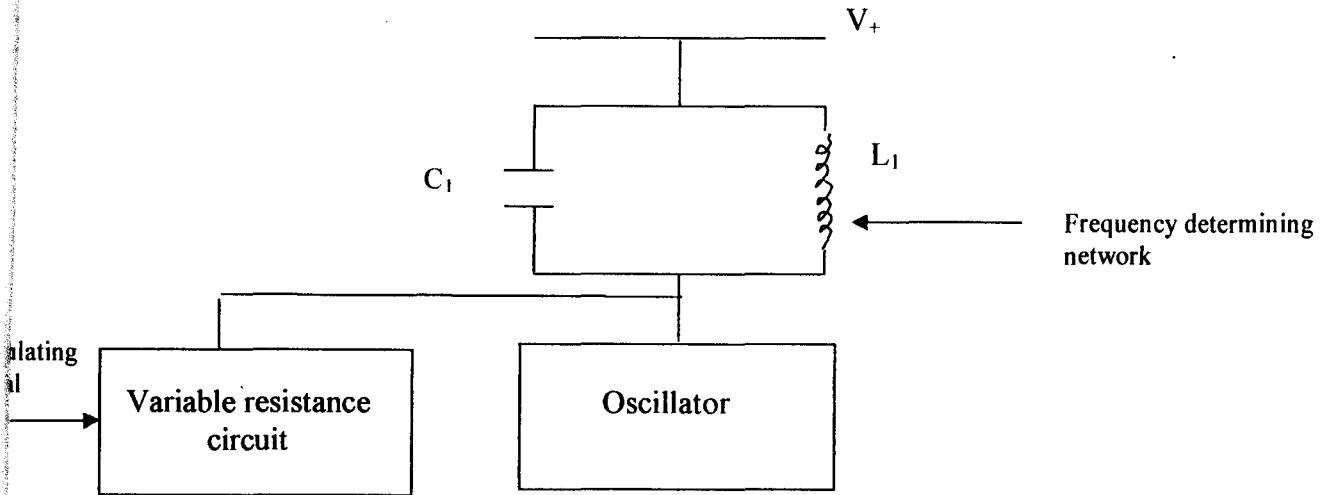

Fig. 3.19 Block diagram of direct frequency modulators

A circuit whose reactance, generally capacitive, can be controlled by the modulating signal is connected in parallel with the frequency determining type circuit $L_1 - C_1$ of the oscillator. A preset resistor from the output of the tone generator is used to vary the modulation index. This varies the amplitude of the modulating signal produced by the tone generator and hence the frequency deviation. When the modulating signal voltage is zero, the effective capacitance C_e of the variable – reactance circuit is such that the oscillation frequency is equal to the unmodulated carrier frequency. i.e.

$$f_{osc} = \frac{1}{2\pi\sqrt{L_1(C_1+C_e)}} = \frac{1}{2\pi\sqrt{L_1C_1}} \text{ Hz} \dots\dots\dots i$$

When the modulating signal is applied, the effective capacitance of the reactive circuit will be varied and thus in turn, will frequency modulate the oscillator

Let C_T change by an amount δC , then

$$f_{osc} + \delta f_{osc} = \frac{1}{2\pi \sqrt{C_T + \delta C_T}} \dots\dots\dots ii$$

Dividing equation (ii) by (i) give:

$$1 + \frac{\delta f_{osc}}{f_{osc}} = \sqrt{\frac{C_T}{C_T + \delta C_T}} = \frac{1}{\sqrt{1 + \frac{\delta C_T}{C_T}}} \dots\dots\dots iii$$

Since $\delta C_T \ll C_T$, equation (iii) can be written using the binomial theorem as:

$$1 + (\delta f_{osc}/f_{osc}) = 1 - (\delta C_T / 2C_T) \dots\dots\dots (iv)$$

Or $\delta f_{osc}/f_{osc} = - \delta C_T / 2C_T$

Equation (iv) states that a fractional increase in C_T will produce a fractional decrease in f_{osc} , which is approximately half as large.

Most direct frequency modulators are either some form of reactance frequency modulator or a varactor diode modulator.

The circuit of a transistor reactance modulator is shown below. Resistors R_1 , R_2 , R_3 and capacitors C_1 are the usual bias as decoupling components. Capacitor C_3 is a dc blocking

components which is necessary to prevent L_2 shorting the dc collector potential of I_1 to ground inductor L_1 is a radio frequency choke.

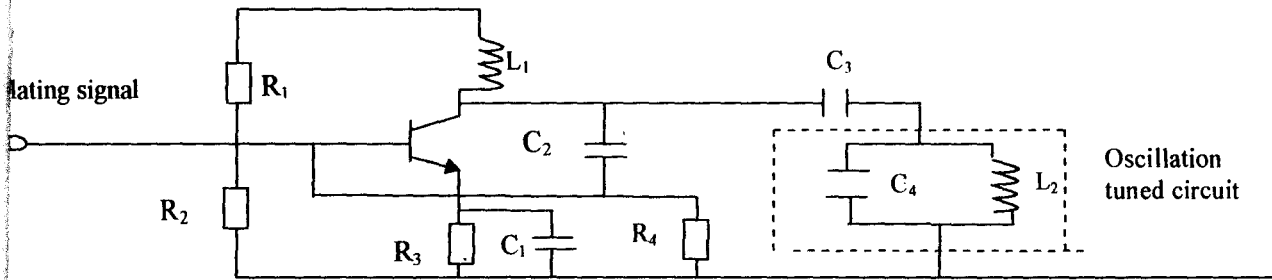

Fig 3.20 Transistor reactance modulator

The current i flowing in C_2 and R_4 is

$$i = \frac{V_{ce}}{R_4 + (1/j\omega C_2)} = \frac{V_{ce} j\omega C_2}{1 + j\omega C_2 R_4}$$

The voltage developed across R_4 is iR_4 and so the collector voltage of transistor T_1 is

$$\frac{g_m V_{ce} j\omega C_2 R_4}{1 + j\omega C_2 R_4}$$

The admittance ratio of the circuit is the ratio i/V_{ce} or

$$Y_{out} = \frac{g_m V_{ce} j\omega C_2 R_4}{1 + j\omega C_2 R_4} = jg_m C_2 R_4$$

Thus the circuit acts as the reactance of a capacitor whose value is $g_m R_4 C_2$. Frequency modulation of the oscillator frequency requires that the effective capacitance of the circuit be varied by the modulating signal. Since the capacitance is directly proportional to the mutual conductance of the transistor, it can be varied by applying the modulating signal to the base of T_1 . The impedance shunted across the oscillator tuned circuit by the modulator will have resistive component also, and this will lead to unwanted amplitude modulation of the oscillator.

Often this amplitude modulation is small and can be tolerated. If it cannot, a limiter is used to remove the amplitude variation.

The FM base reactance modulation used in this circuit design is shown below in fig.

3.21

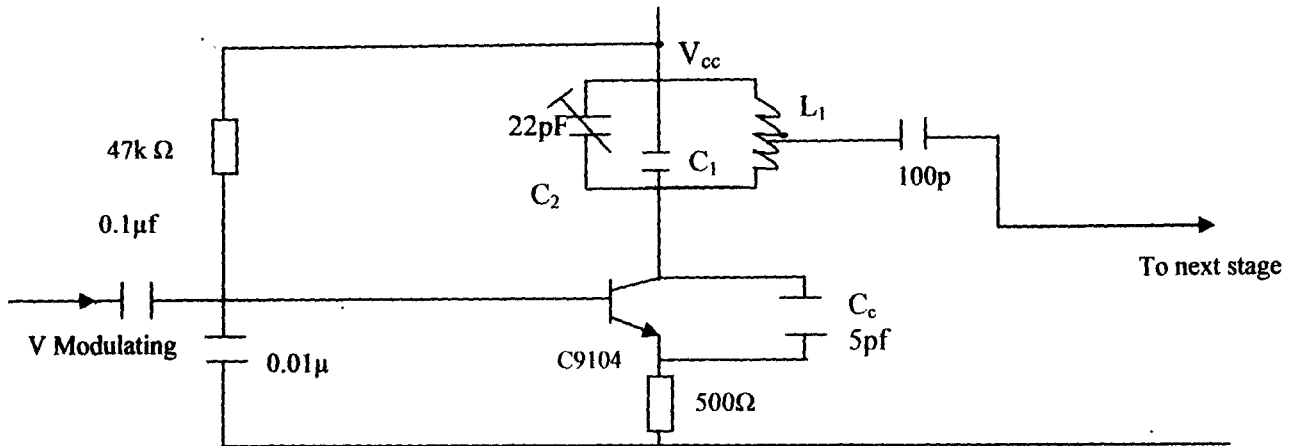

Fig 3.21 FM base reactance modulator

The transmitter is an npn transistor connected in the common base (CB) mode (the CB configuration offers the best high frequency response). In the common base mode, miller effect is eliminated and the large CE capacitance is no longer part of the output turned circuit like is in the common emitter (CE) mode.

With no modulating signal, the AC equivalent of the CB stage is as depicted below in fig 3.22

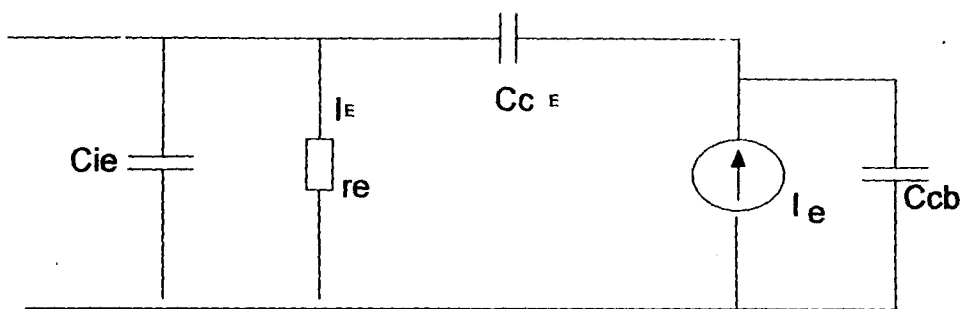

Fig. 3.22 Tuned collector stage

C_{CE} forms parts of the C – E feedback capacitance shunted by a 5pf external capacitance, and C_{cb} forms part of the capacitance of the tuned collector stage.

When a modulating signal is applied to the base of TR1, C_{cb} is effectively magnified by a factor proportional to the conductance of the transistor. This change in C_{cb} is translated to a change in oscillator frequency since C_{cb} is now effectively part of the frequency determining network as shown below in fig. 3.23

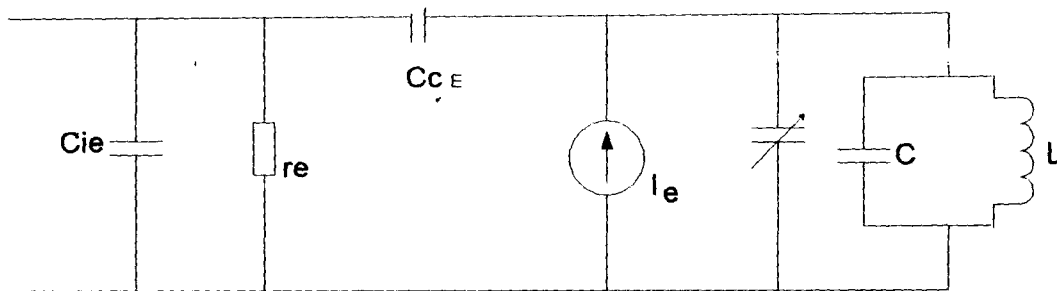

Fig. 3.23 Tuned collector stage coupled with a frequency determining network

The transistor modulator is built around an npn C9014 transistor.

For an amplifier in the CB mode, the base terminal is assumed clamped at 0V by the large base –earth capacitance. The output-tuned circuit is in the collector base junction and a 5pf collector to emitter capacitance provides coupling of RF energy to sustain oscillation.

Varying V_{mode} varies C_{cB} , which in turn varies f_{osc} since it is part of the output tuned circuit.

3.4.3 DETERMINING THE MODULATION INDEX.

The rate at which frequency shifts (also called frequency deviation) take place depends on the signal frequency. If for instance the modulating signal is 1KHz, then the modulated carrier wave will swing between its maximum frequency and lowest frequency 1000 times per second.

From the aforementioned, it can be deduced that: the amount of frequency deviation (or shift or variation) depends on the amplitude (loudness) of the audio signal. The louder the sound the greater the frequency deviation and vice versa. Also the rate of frequency deviation depends on the signal frequency.

The modulation index, m_f is given by the ratio

$$m_f = \frac{\text{frequency deviation}}{\text{modulation frequency}} = \frac{\Delta f}{f_m} \quad [3]$$

The mean (unmodulated) oscillation frequency of the oscillator was determined as 92MHz and since a single 1KHz tone modulates its base reactance capacitance, a very narrow bandwidth of theoretically ± 5 KHz was assumed. The modulating signal was 2v.

The peak frequency deviation (or carries swing) is 10Khz. From thee above, the modulation index for the circuit is calculated as.

$$m_f = \frac{\text{frequency deviation}}{\text{modulation frequency}} = \frac{5 \times 10^3}{1 \times 10^3} = 5$$

3.5 THE OUTPUT

The circuit is designed to give a two – way output consisting of a speaker (or siren) and an antenna. The speaker makes a loud noise as soon as the alarm is triggered either in the latched or unlatched mode. The purpose of the speaker is to alert neighbours or person in the vicinity about the presence of an intruder or burglar. In this way, help can be solicited from neighbours or even in some cases scare the burglar away. The speaker, which has an impedance of 8ohms, is driven by the output (pin 3) of the tone generator (555 timer) as shown below in fig.

3.24

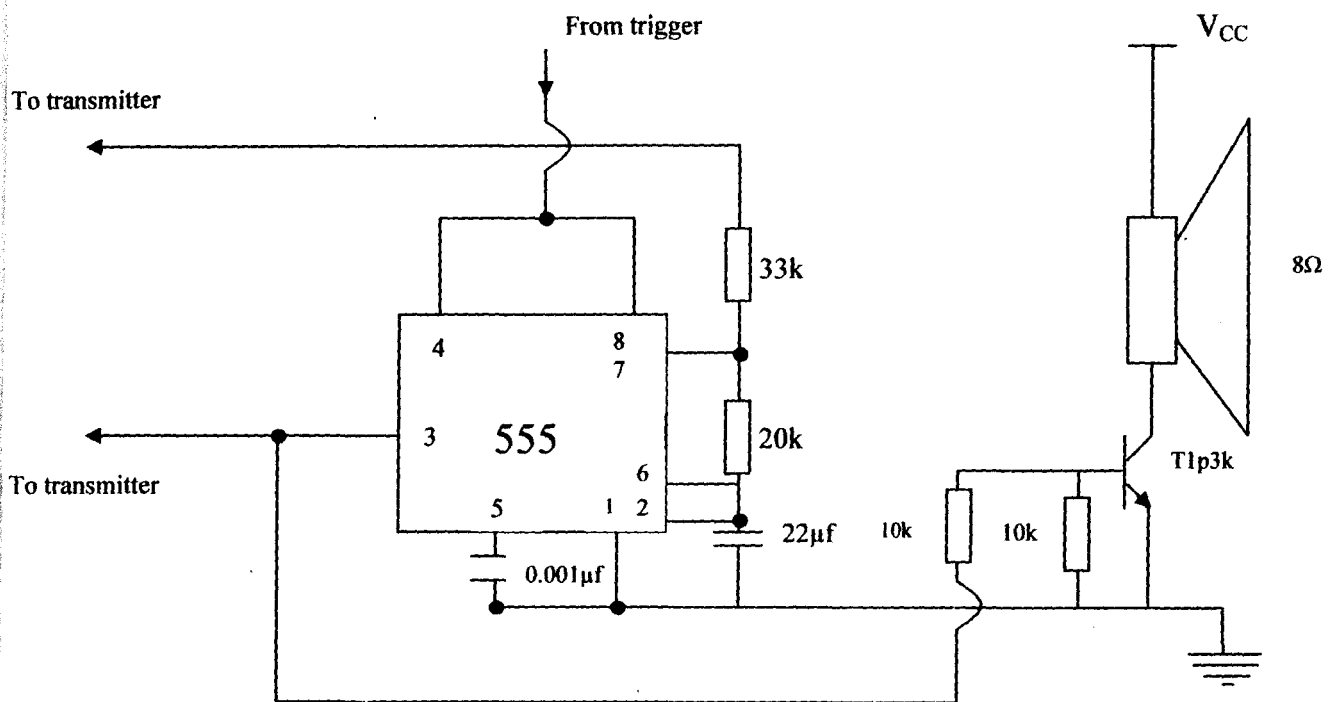

Fig. 3.24 An 8 ohm speaker driven by the output from the tone generator

The output from the tone generator is an astable multivibrator is passed through a 10KΩ limiter. The 10KΩ resistor provided a base bias for the T1P3k transistor, which serves to amplify the signal that drives the speaker. The result is a loud sound oscillating at a frequency of 1KHz.

The speaker is a transducer, which converts electrical signal from the output audio frequency amplifier into sound. The second output is the antenna, which radiates the signal from the transmitter into space.

An antenna is a structure that is generally a metallic object, often a wire or group of wires, used to convert high frequency current into electromagnetic wave and vice versa. It is designed to provide an effective coupling between space and the output of a transmitter of the input to a receiver [6]

Since electromagnetic waves are propagated at the speed of light, the frequency (f) and the wavelength (λ) of a radio wave are related to the velocity of light (v) by the equation;

$$V = f\lambda, \quad \lambda = V/f$$

Where $V = 3 \times 10^8$ m/s

From the above equation, it can be seen that the wavelength of a signal is inversely proportional to its frequency. Thus a very high frequency wave has a much shorter wavelength than a low frequency wave. This explains the use of very high frequencies as carrier waves to transmit signals as it reduces the size of the antenna required.

This project is designed to transmit on FM wave at a frequency of 92Mz. The wavelength λ is calculated as;

$$\lambda = V/f = \frac{3 \times 10^8 \text{ m/s}}{92 \times 10^6 / \text{s}} = 3.26 \text{ m}$$

For effective radiation of a signal, the maximum length of an antenna is one-quarter wavelength ($\lambda/4$) [3].

So the length of the antenna used in the circuit is calculated to be

$$\frac{3.26\text{m}}{4} = 0.815\text{m}$$

The diagram showing the connection of the antenna to the transmitter section of the circuit is depicted below:

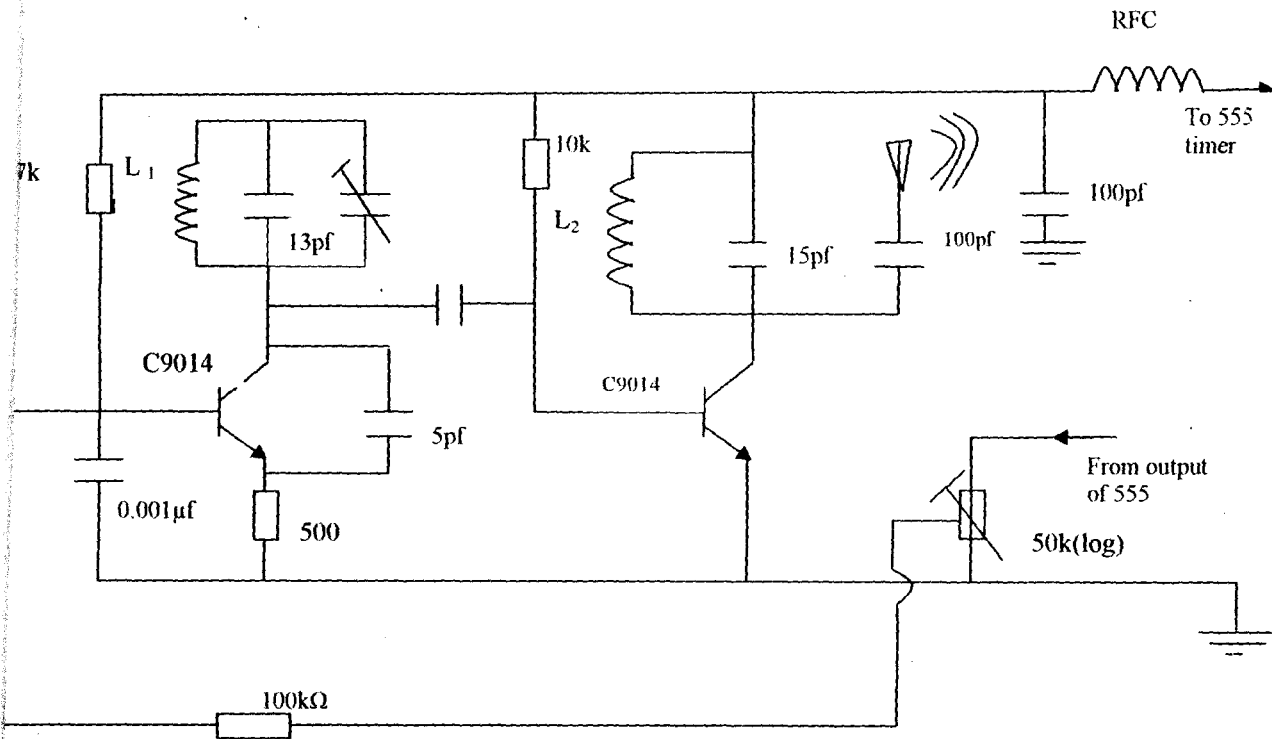

Fig. 3.25 Coupling of the antenna to the transmitter

The output from the 555 timer is passed through a preset resistor for purposes of adjusting the modulation index. The 100kΩ resistor provides a base bias for the modulator. The modulator consists of a C9014 transistor connected in common base configuration. The tank circuit comprising of a parallel combination of L₁, a 15pF capacitor and a variable capacitor form an

oscillator, which generates the carrier wave. The output of the tank circuit is coupled to the collector of the modulator from where a coupling capacitor is used to couple the modulated signal to the next stage.

The last stage consist of another C9014 transistor which serves to amplifier the modulated signal before it is coupled to the antenna which radiates the signal into space. It should be noted that the antenna is coupled to the circuit via another tank circuit provided by L_2 , a 15pf and a 100pf capacitors, which resonate at the frequency of transmission (circuit wave frequency). The frequency choke (RFC) provides dc load for the circuit and also keeps ac currents out of the dc supply [3], [4], L_1 and L_2 are both formed from 7 turns of 22 swg copper wire and serve as inductors in the tank circuit.

The purpose of the antenna being incorporated into the circuit to transmit the alarm signal to a remote destination or even a nearby police station for remote assistance. It can also serve to notify the owner of the house of the presence of unwanted guest at his house in his absence. So the output from the circuit provides a means of signaling for nearby as well as remote assistance as provided by the speaker (or siren) and the antenna (transmitter) respectively.

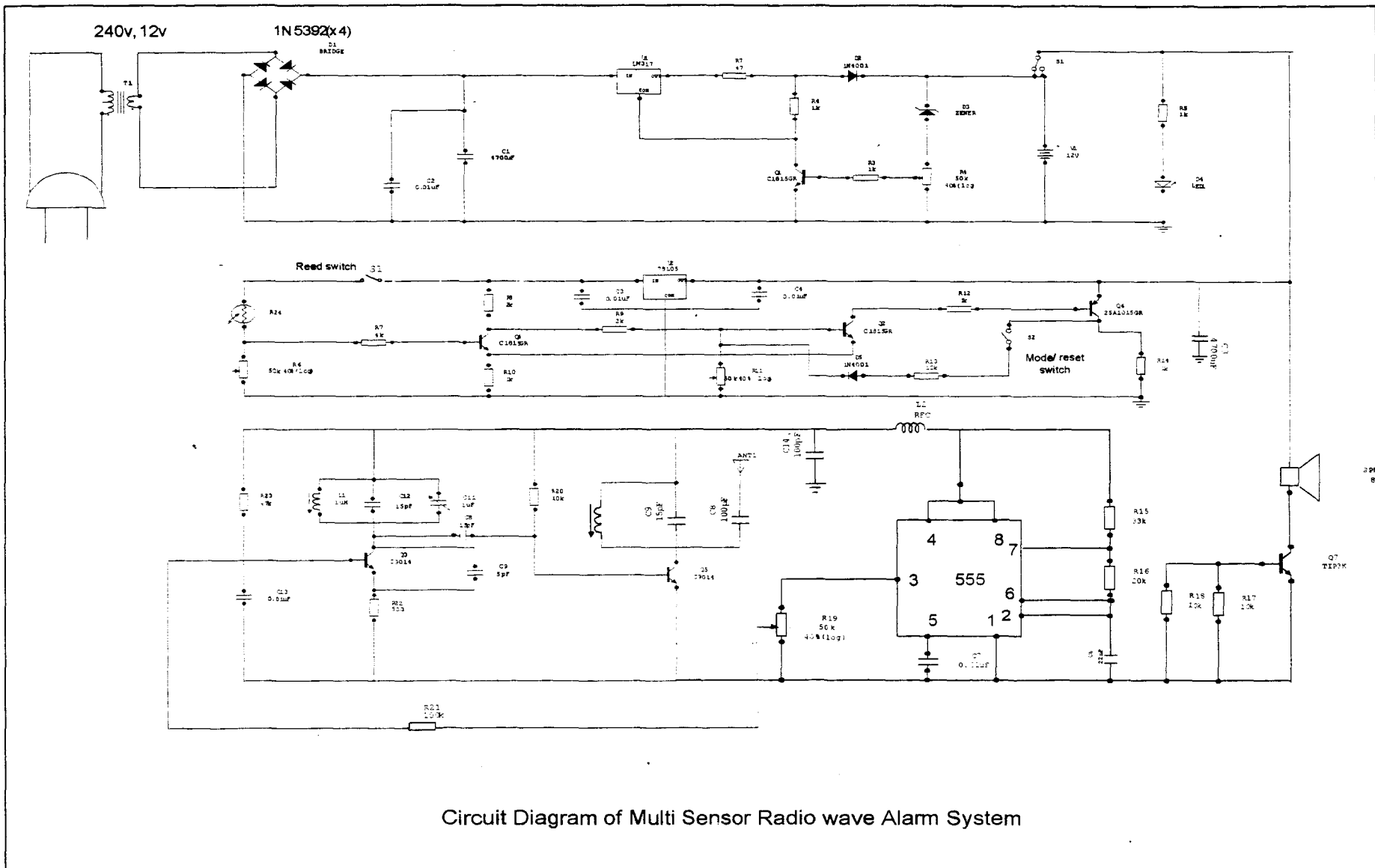

CHAPTER FOUR

CONSTRUCTION AND TESTING

4.1 CONSTRUCTION

The project is enclosed in a well crafted tile casing it has an easily removable top for easy access to the circuit components.

The unit is carefully constructed and housed in three (3) compartments viz:

- i. The transformer section
- ii. The battery charging section
- iii. The printed circuit board section in which the circuit components are connected.

In order to facilitate construction, the project was first constructed on a bread board. This helps to facilitate easy troubleshooting of the circuit. Also this ensures that all faults detected are corrected before the components are finally soldered together on a printed circuit board (pcb). This is very important to prevent multiple soldering and de-soldering of circuit components from the printed circuit board (pcb) in the event of fault detection as well as protect the components from damage.

Care was exercised when handling components particularly the sensitive ones (such as ICs) to avoid damage due to statics.

Components such as; diodes, electrolytic capacitors and transistors were connected properly with respect to their polarities to avoid damage or non-functionality. The components were well spaced during connection for easy access to faulty components in addition to providing ease in fault tracing. Proper spacing also helps to check capacitive build up between components when they are connected in close proximity. At least 15 – 20 seconds is allowed between joints in order to prevent the building up of heat which may destroy the components.

After soldering, the leads were trimmed with a sniper. Also during deflecting (de-soldering) a small brush was used to dislodge stubborn globes of flux. ✎

The LDR is enclosed in a hollow casing to remove or isolate ambient light sources which can disrupt normal operation of the circuit. A toggle switch is used to mimic a reed switch operating on a normally closed condition. The alarm is triggered once the switch is opened. Also a mode select/reset switch toggles the circuit operation between the latched and unlatched mode.

The circuit is ac powered as well as dc powered. When the circuit is ac powered, the dc supply is interrupted. However, as soon as ac power is cut off, dc operation takes over immediately. So the dc supply provided by the 12volts battery (2 x 6v batteries) serves as an independent power source/back up for the ac operation. This is particularly important to ensure continuous powering of the circuit in the event of ac power failure or in the event of an intruder disconnecting the source of ac supply from the mains. The ac supply in addition to powering the circuit, also charges the 12volts battery when connected in stand by mode.

4.2 Testing

After construction, tests were carried out to ensure that the circuit operates as designed.

The test was first conducted in the latched mode i.e. when the Schmitt trigger is operating in the full alarm mode. Under this condition, the alarm is inactive when the LDR is illuminated by the light source or the switch is in the closed condition. As soon as the source of illumination is obstructed or the switch is opened the alarm is triggered and a loud sound is heard through the speaker. It remains latched (locked) in this mode even after the source of illumination is restored or the switch returned to the normally closed conditions. To deactivate the circuit the mode select/reset switch is pressed twice to reset the circuit.

In the unlatched mode, when the source of illumination to the LDR was blocked or the switch opened, the alarm sounded through the speaker only for the duration the obstruction remained, or the switch was opened and was deactivated as soon as the source of illumination was restored or the switch returned to the closed condition.

4.2.1 RESULTS

A radio receiver was used to tune to the transmission frequency to test the reception of the alarm. A continuous signal at a frequency of 1 KHz was heard clearly on an FM radio operating at a frequency of about 92MHz. The signal range or range of reception was put at about 50m. The results obtained were thus very satisfactory.

4.2.2 DIFFICULTIES ENCOUNTERED

Some of the difficulties encountered included obtaining the simulation results for the circuit as some times the simulation of the circuit gave simulation convergence errors. This was later resolved by adjusting simulation parameters on the CAD (Computer Aided Design) program. Secondly, the circuit components used in the CAD program were not readily available at the stores.



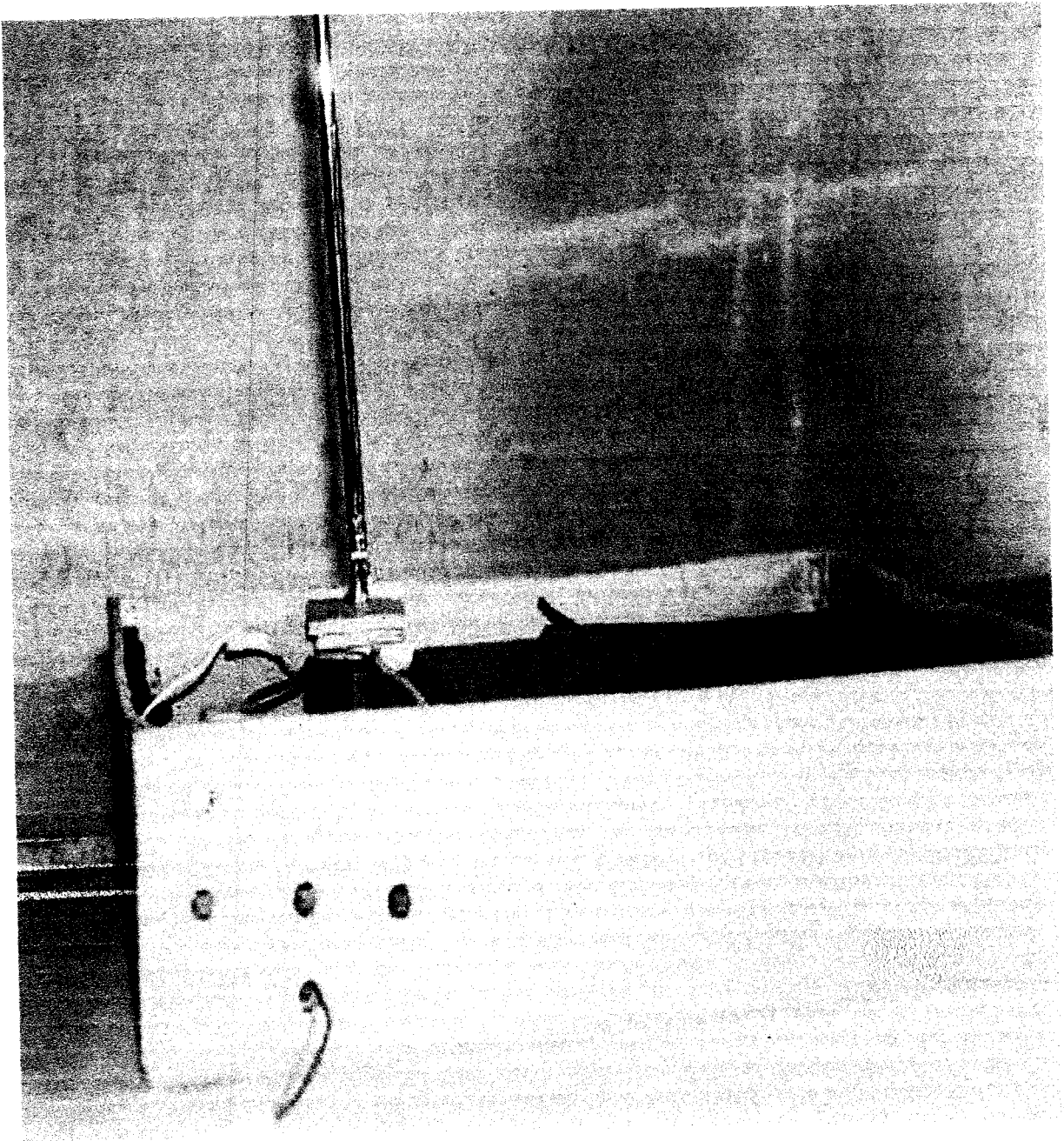

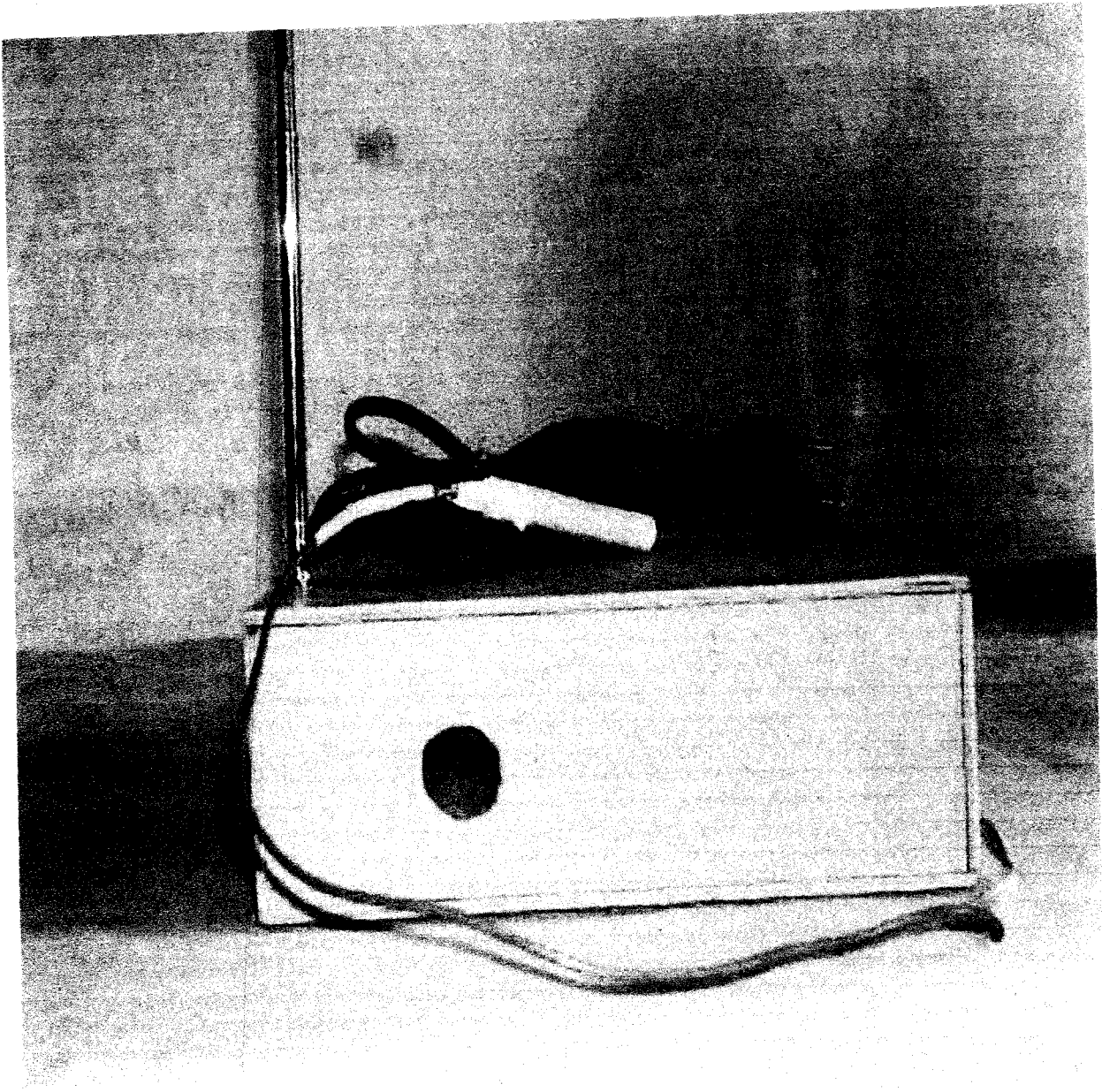

CHAPTER FIVE

CONCLUSION AND RECOMMENDATION

5.1 CONCLUSION

The project was designed to transmit alert or alarm signals via radio wave using the light dependent resistor (LDR) and a magnetic reed switch as the sensors / detectors. It sought to provide an efficient and effective means of crime detection as well as providing a means of rapid response to curtail crime. The work reiterates the fact that crimes are better handled if they can be prevented or nipped in the bud before they are committed. The results obtained were very satisfactory.

5.2 RECOMMENDATION

This neat and portable device will be very useful in homes as a kind of burglar or security alert system to indicate the presence of an intruder. It provides a means by which a house owner can keep abreast of the security situation at his home while present or away from home.

Industries will find it useful in monitoring certain production parameters. It will also enable security outfits to monitor restricted areas and indicate the presence of any unauthorized person(s) e.g. high voltage transmission areas or perimeter fences.

However, there is still room for improvement. Areas for enhanced performance include:

- i. Incorporating a counter in the unlatched mode of the circuit for counting the number times a door has been opened or in industries for counting the number of items e.g. bottles in a bottling plant that has passed through a particular point.

- ii. By modifying the sensor to fit the particular application, it can be adapted in industries to monitor changes in parameters e.g. temperature, pressure, light intensity and to notify personnel when such parameters rise above or drop below acceptable levels.
- iii. An auto dialer function can be incorporated into the design to automatically dial a location or a service utility e.g. fire station in the case of a fire outbreak. This will complement the functions of the speaker and the antenna outputs.
- iv. By incorporating a microcontroller into the design a lot of dedicated functions can be performed for instance, tuning on a sprinkler, shutting or locking all doors, turning on all the lights and many more.

References

- [1]. Donald L. Twrell, Encyclopedia of science and Technology, MC Graw Hill, vol. 2, 1982 pp. 305
- [2]. Marvin Rierrman, RCA Institutes Inc., Encyclopedia American international Edition. Groiler Incorporated, Vol. 4, pp. 788.
- [3]. B. L. Theraja and A.K. Theraja, A textbook of electrical technology, S. Chand and Company, Ram Nagar; New Delhi – India, 2002, pp 225 – 228, 1022, 1029, 1030, 1035 – 1036, 1957, 2204, 2213 – 2217.
- [4]. Paul Horowitz and Winfield Hill, The art of electronics, second edition, Cambridge University Press, Cambridge-United Kingdom, 2002. pp. 883.
- [5]. Edward Hughes, Hughes electrical and electronic technology, Pearson Educational Limited, Delhi India, 2002, pp. 387, 392.
- [6]. George Kennedy and Bernard Davis, Electronic Communication Systems, Fourth Edition, MC Graw – Hill Publishing Company Limited, New Delhi – India, 1999, pp. 80, 256, 303.
- [7]. I. Zherebtsov, Basic electronics. Mir Publishers Moscow – Russia, 1988, pp. 291 -292.
- [8]. Michael Talbot – Smith, Audio Explained pp. 14.
- [9]. Tony Van Roon, 555 timer tutorial,
<http://www.uoguelph.ca/nantenna/gadgets/555/555.html>, [555timer/osillationtutorial](http://www.uoguelph.ca/nantenna/gadgets/555/555.html).
- [10]. National Semiconductor Corporation, on line data sheets <http://www.national.com>.

Appendix

LIST OF COMPONENTS USED

The following components were employed in the construction of the project.

RESISTORS

1k ohm (x4)

10k ohm (x5)

Variable 50k ohm (x4)

2k ohm (x2)

4k ohm

33k ohm

20k ohm

47k ohm

100k ohm

500 ohm

47 ohm

Light dependent resistors (LDR)

CAPACITORS

$0.01 \times 10^{-6}\text{F}(x5)$

16v, $4700 \times 10^{-6}\text{F}(x2)$

$15 \times 10^{-12}\text{F}(x2)$

$100 \times 10^{-12}\text{F}(x2)$

$5 \times 10^{-12}\text{F}(x2)$

$22 \times 10^{-9}\text{F}$

1 variable capacitor

DIODES

IN5392 (bridge rectifier) (x4)

IN 4001(x4)

12v zener

TRANSISTORS

C1815GR npn(x3)

C9014 npn(x2)

25A1015GR pnp

TIP 3k npn power transistor

OTHERS

Inductors – 7 turns of 22 swg(x2)

Radio frequency choke

240, 12v transformer

LM 317T Adjustable voltage regulator

7805 5vregulator

Toggle switches (x3)

555 timers IC

8 ohm speakers

Ferrite antenna

Light emitting diode (LED)

6v lead –acid batteries (x2)