

**DESIGN AND CONSTRUCTION OF AN
UNINTERRUPTIBLE MOSQUITO
REPELLENT**

BY

**AMAH. N. MATHIAS
2003/15321EE**

**A THESIS SUBMITTED TO THE DEPARTMENT OF
ELECTRICAL AND COMPUTER ENGINEERING FEDERAL
UNIVERSITY OF TECHNOLOGY MINNA, NIGERIA**

NOVEMBER, 2008

DEDICATION

This project is dedicated to GOD almighty for his protection and guidance throughout my academics pursuit.

DECLARATION

I Amah .N. Mathias declares that this work was done by me and has never been presented elsewhere for the award of degree. I also here by relinquish the copyright to the federal university of technology, Minna.

Amah .N. Mathias

Name of Student

DR. E.N. Onwuka

Name of Supervisor

 14/11/08
Signature and Date

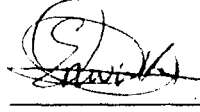
 10/11/08
Signature and Date

Prof. Y.A. Adediran

Name of H.O.D

Name of External Examiner

Signature and Date

Signature and Date

ACKNOWLEDGEMENT

My profound gratitude goes to GOD almighty that has seen me through my academic pursuit. I will also want to express my gratitude to my supervisor DR E.N. Onwuka who has been of immense assistance to make this work a success both morally and intellectually by critiquing constructively until the best was produced.

My appreciation also goes to the head of department, Prof.Y.A Adediran for drilling us as raw material into finished products.

My regards also goes to all the staff of electrical/computer engineering Eng. M.S Ahmed , Mr. E. Eronu, Mr. J.K .Kolo, MR. M. David and a host of others. There is a saying that says he that is grateful to man is not grateful to God, hence I will want to appreciate my parent chief Mr. and Mrs. Matthias Amah for their moral and financial support, my big brothers, Nonso ,Chinweuba ,Leonard and my sisters Oluchi and Mrs. Adaku Enujuba.

My sincere appreciation also goes to my in-law; Mr. Ernest Enujuba's for his moral and financial support and I say God blessing you all.

ABSTRACT

Uninterruptible power Electronic mosquito repellent is a device that repels mosquito in a modern and clean way without using any potentially harmful chemical. The theory behind operation of this device is quite simple and amazingly effective. When female mosquitoes are pregnant they prefer to stay away from the male mosquito and to search for food (blood). This circuit produces the ultrasonic sound of the same frequency with that the male mosquito produces and this in turn repels the female mosquitoes. Research has proven that the sound produced by male mosquito is about 40 kHz which is an ultrasonic sound within a certain radius of five meters as designed.

TABLE OF CONTENTS

Dedication.....	ii
Declaration.....	iii
Acknowledgement.....	iv
Abstract.....	v
Table of content.....	vi
Chapter one:	
1.0 Introduction.....	1
1.1 Mode of control of mosquito	1
1.2 Mode of feeding	2
1.3 The flight habit of mosquitoes.....	2
1.4 Life cycle	3
1.5 Objective	4
Chapter Two: Literature review	
2.0 Historical back ground	5
2.1 Characteristics of Ultrasonic frequency	6
2.2 Application of Ultrasonic	7
2.2.1 Ultrasonic flaw detector.....	7
2.2.2 Heating by ultrasonic.....	7
2.2.3 Medical use.....	7
2.2.4 Chemical effect.....	8
2.3 Functions of Some Basic Components Used...8	
2.3.1 Voltage regulator.....	8

2.3.2 Light Emitting Diode (LED).....8

2.3.3 Integrated Circuit 555timer IC.....9

Chapter Three: Design and Construction

3.0 Design and Implementation10

3.1 Ultrasonic insect repellent system11

3.2 Power Supply12

3.3 Battery Charging Subsystem14

3.4 Analysis15

3.5 Light Detector18

3.6 40 kHz High Frequency Oscillator.....19

3.7 Complete Circuit Diagram of Uninterruptible
Power Electronic Mosquito Repellent22

Chapter Four

4.0 Construction, Testing, Result and Casing23

4.1 Construction23

4.2 Observation23

4.3 Testing24

4.4 Result24

4.5 Case Construction25

4.6 Problems encountered25

4.7 Solution proffered26

Chapter five

5.1 Conclusion27

5.2 Recommendation28

References 29

CHAPTER ONE

1.0 INTRODUCTION

The uninterruptible power electronic mosquito repellent device repels mosquito in a modern and clean way without using any harmful chemical repeller.

Female mosquitoes are the ones that bite. When they are pregnant, they tend to isolate themselves from the male mosquitoes. [1] This device emits an ultrasonic sound, which research has shown to be approximately of the same frequency with that produced or emitted by the male mosquito, which in turn form an antipathy to the female mosquito [2].

1.1 MODE OF CONTROLLING MOSQUITOES

Though there are many methods of mosquito control, like the cultural method, traps, and chemicals and so on, but it's been observed that a low intensity ultrasonic sound emitter repels mosquitoes and other household pest such as rodents. It can be used in all seasons, anywhere and anytime. The electronic mosquito repellent have been proved as one of the best methods of mosquito control in the world so far [3], in the sense that it's harmless and cause no discomfort to user and environment, since the sound it produces is almost inaudible to humans and so can be used at homes. The ultrasonic mosquito repellent that is electronic mosquito repellent can be used anywhere within a given range of five to seven meters at homes, farmland and camping ground. That is it can be used for both indoor and outdoor purposes. [4]

Mosquitoes and man can never be best of friends. They are enemies of man. They are found around the world especially in South America, Greenland, South-east Asia and tropical Africa [5].

1.2 MODE OF FEEDING

The feeding habits of mosquitoes are quite unique in that it is only the adult females that bite man and other animals. The male mosquito prefers to feed only on plant juices. Some female mosquitoes prefer to feed on only one type of animal or they can feed on a variety of animals, female mosquito feed on man, domesticated animals such as cattle, horses, goats and so on, all types of birds including chickens, all types of wild animals including deer, rabbits, and also feed on snakes, lizards frogs and toads.[6]

Most female mosquitoes have to feed on animals, to get sufficient blood meal before they can develop eggs. If they do not get blood meal then they will die without laying viable eggs, however, some species of mosquito have developed the means to lay viable without getting blood meal.

1.3 THE FLIGHT HABIT OF MOSQUITOES

The flight of mosquito depends again on the species with which we are dealing. Most domestic species remain fairly close to their point of origin while some are known for their migration habits. The flight range for female mosquito is usually longer than that of males, most times wind is a factor in the dispersal or migration of mosquito, most mosquito stay within mile or two of their sources however, some have been recorded as far as 75 miles from their breeding source. [3]

The length of life of adult mosquito usually depends on several factors which are: temperature, humidity, sex of the mosquitoes, and time of year. Most males live for a short time of about a week, while female mosquitos live for about a month depending on the factor above.

Mosquitoes of different species lay their eggs in a variety of waters source that ranges from small containers to vast expenses of marshland [7]. The larval stage is always aquatic and shuttles from the subsurface where it filters feeds on micro-organism to the surface to obtain oxygen through a snorkel-like breathing apparatus. The mosquitoes in the pupa stage does not feed unlike other insects pupae of mosquitoes are extremely active , the adult emerges from the pupa case using air pressure and assume a terrestrial existence.

This device is designed to be able to get rid of mosquitoes from our environment by repelling female mosquito which bites humans; this will improve the health and well being of man. [7]

Although as earlier mentioned other means of checking these undesirable creatures exists for instance, the use of chemicals such as insecticides e.t.c. But the danger they post to human health constitutes a more serious problem than the pests and insects they are employ to drive away. Besides the dangers they pose to human health, insects like mosquitoes have a way of adapting to such chemical measures by developing a sort of stiff resistance having occasionally survived chemical attacks hence rendering certain ineffective against their use in control solving this problem constituted the objectives of this projects.

This device could use ultraviolet light source to achieve this aim but for this project an ultrasonic sounds mimicking human presence could be electronically generates to keep insects away, some also make use of high audible ultrasonic sounds to achieve this purpose.

9]

5 OBJECTIVE

1. The aim of this project is to design and construct a device that will repel mosquitoes from our environment without the negative side effect that chemical repellents have.

1.5 OBJECTIVE

- 1. The aim of this project is to design and construct a device that will repel mosquitoes from our environment without the negative side effect that chemical repellents have.**
- 2. To eradicate some common diseases caused by mosquito bit such as malaria, typhoid e.t.c.**
- 3. To reduce mortality rate in children.**

CHAPTER TWO

LITERATURE REVIEW

2.0 HISTORICAL BACKGROUND

The mosquito problem is a part of everyday life, especially during the rainy season. For the past centuries, inventive people have struggled hard to find effective means of protection against this insect. It is a known fact that, only the females are dangerous, the male can also create panic situation by their irritating sound. [9] Though there are so many other methods of mosquito or malaria vector control such as cultural method physical attack and the use of insecticide and so on but it's been discovered that a low intensity ultrasonic sound emitter can repel mosquito with the sound it produces this can be used at all times seasons. [8]

The unit produced is needed to repel pregnant female anopheles mosquito, which is the major vector spreading malaria parasite to the human race Also included in the design is a pest house hold insect repelling circuit which can also keep insect at bay from our homes and farm land. In Africa about 10% to 50% of our food crops are lost annually to insects both on the fields and in stores, at home and most of the method so far applied to control these mosquitoes .e.g. traps (light traps that are used in homes, farms and stores have not done anything better, as it can only be used during nights to trap nocturnal insects), chemical (involves the use of insecticides like mobile, raid, mosquito coils). These mentioned chemicals are not good on all the edible food crops especially those with edible leaves. The effects of these chemicals will not be discoursed as it is beyond the scope of this work. And cultural method (involving picking of mosquitoes with hands) has not been too effective. [9]

Generally it has been discovered that a low intensity ultrasonic sound wave in the range 39 kHz to 40 kHz frequency band repel mosquito. This discovery has led to birth of this ultrasonic mosquito repellent, ultrasonic is the study and application of high frequency sound waves ,usually in excess of 20khz(20,000 cycles per second) [10]. Modern ultrasonic generator can produce frequency of as high as several gigahertz (several billion cycle per second) by transforming alternating electric current into mechanical oscillation, and scientist have produced ultrasonic with frequencies up to about 10 GHz(ten billion vibrations per second) this maybe an upper limit to the frequency of usable ultrasound ,but it is not yet known. [11]

2.1 CHARACTERISTIC OF ULTRASONIC FREQUENCY

High frequencies have shorter wave length, which allows them to reflect from object more readily and to provide better information about those objects. The measurement of ultrasonic wave is accomplished mainly through the use of piezoelectric receivers or by optical means. The latter is possible because ultrasonic wave are rendered visible by the diffraction of light. Ultrasound is far above the range of human hearing, which is only about 20hz to 20khz however some mammals can hear well above this for example, bats and whales use echo location that can reach frequencies in excess of 100khz the roots of ultrasonic technology can be traced back to research on the piezoelectric effect conducted wire by Pierre Curie around 1880. He found that asymmetrical crystal such as quartz and rocheve salt (potassium sodium titrate) generate an electric charge when mechanical pressure is applied conversely, mechanical vibration are obtained by applying electrical oscillation to the crystal. The ultrasonic sound produced by 555 timers at a frequency of 40khzis used to repel mosquito [12].

2.2 Some applications of ultrasonic include: [2]

1. Ultrasonic flaw detection
2. Heating by ultrasonic
3. Medical uses
4. Chemical effect

2.2.1 ULTRASONIC FLAW DETECTOR

In metal, there may arise a foreign material or there may be crack in metals which is not visible to the eyes. This discontinuity hampers metal part. Ultrasonic find a very useful application in locating or detecting irregularities [13].

2.2.2 HEATING BY ULTRASONIC

With the increase of frequency of ultrasonic waves, the heat generated is increased due to increase in absorption [13]. Diathermic devices in which ultrasonic wave are used to produce heat internally as a result of tissue resistance has been used successfully in physical therapy [13].

2.2.3 MEDICAL USE

In medicine, ultrasonic is used as a diagnostic tool, to destroy diseased tissue, and to repair damaged tissue [14]. Ultrasonic wave have been employed to treat bursitis, various types of rheumatoid arthritis, gout, and muscular injuries and to destroy kidney stones. The use of ultrasonic for measuring the rate of flow of blood has been suggested [15].

2.2.4 CHEMICAL EFFECT

Chemical reaction takes place rapidly in the presence of ultrasonic dispersive and coagulates react more rapidly when influenced with irradiation and oscillation from 20KHZ. Oxidation and iodine take place rapidly under ultrasonic [13]

2.3FUNCTIONS OF SOME BASIC COMPONENTS USED

The basic component used in the construction of the device include:, Light Emitting Diode 555timer IC and Speaker, and Voltage regulator.

2.3.1 Voltage Regulator

This regulator has much improve performance; they have a number of built-in features current limiting, self-protection against over temperature, remote control operation over a wide range of input voltages and feedback current limiting.

2.3.2 Light Emitting Diode (LED):

This gives off light when a current passes through them in a forward direction. An LED is a transducer which is used to change electrical energy into a light energy and is made from the semiconductor gallium arsenide phosphate. The LED must be connected in a circuit the correct way, it is to work, its anode must be positive and cathode must be negative.

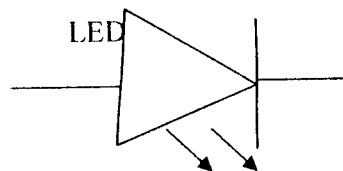

2.3.3 Integrated Circuit (IC):

An IC is a complete electronic circuit in which both the active and passive components are fabricated on a tiny single chip of silicon which are used for oscillator and time delay. ICs are produced by the same processes as are used for manufacturing individual transistors and diodes e.t.c

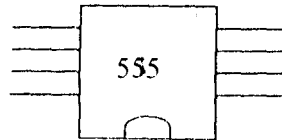

CHAPTER THREE

3.0 DESIGN AND IMPLEMENTATION

Figure 3.0 shows each block representing a stage in the circuit of the uninterruptible power electronic mosquito repellent. The below block diagram shows the full operations of the Mosquito repellent and each block represents a stage in the circuit. There are basically four modules: power supply, Battery chargers, light sensor, and 40 kHz HF oscillator. The supply from PHCN (240VAC) is converted to 12VAC through a step-down transformer. The output of the transformer that is the output of the secondary of the transformer is 12VAC which is needed to be rectified to 12VDC by the use of diode configure as a bridge.

The output of the bridge rectifier is filtered to pure DC voltage which is the applied across the battery charger. Switch controls the current flow in across the light sensor .The 40 kHz oscillator which produces ultrasonic frequency with the help of 555timer configured as a stable vibrator to emit 40khz of frequency through the speaker connected to the output of the 555timer.From the block diagram the whole module was design separately and later joint together to give a complete circuit diagram of uninterruptible power electronic mosquito repellent and constructed to produce a prototype functioning as expected.

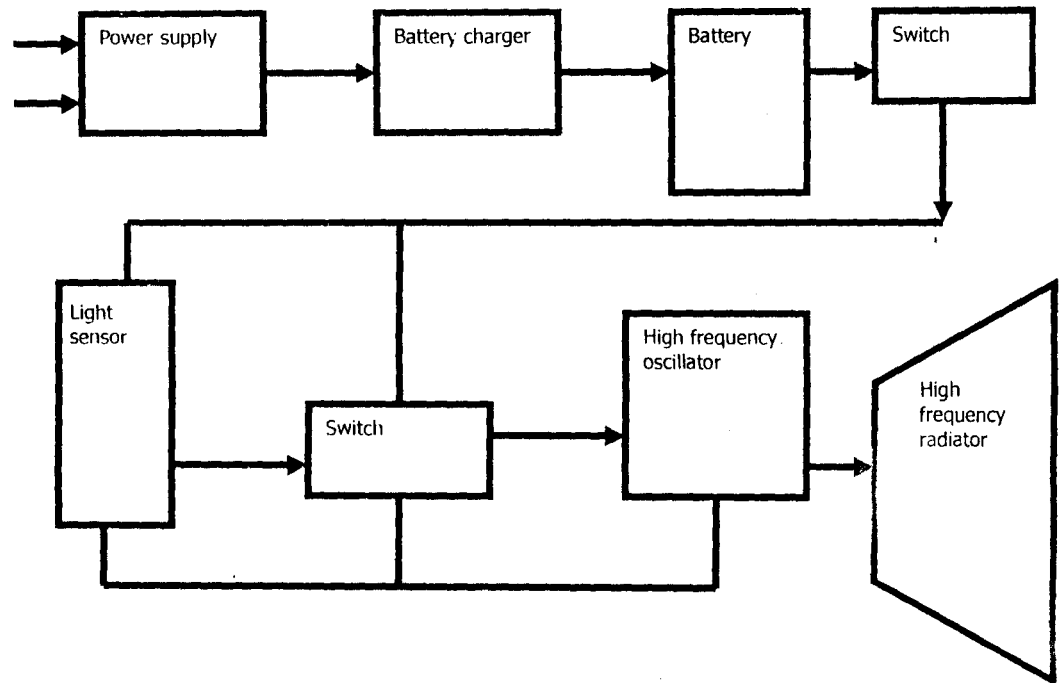

Fig. 3.0: Block diagram of uninterruptible power electronic mosquito repellent device

3.1 THE ULTRASONIC MOSQUITO REPELLANT SYSTEM COMPRISES THE FOLLOWING SUBSYSTEMS.

1. POWER SUPPLY;
2. CONSTANT-CURRENT, CONSTANT-VOLTAGE LEAD-ACID
BATTERY CHARGER;
3. LIGHT SENSOR AND SWITCH;
4. 40 KHz HF OSCILLATORS.

3.2 POWER SUPPLY

A low-voltage (6v-7v) DC was required for system operation. (Mainly for battery charging). This was obtained from a 240V/12V, 0.5A step down transformer. The transformer was connected to a full-wave bridge rectifier as shown in fig 3.2

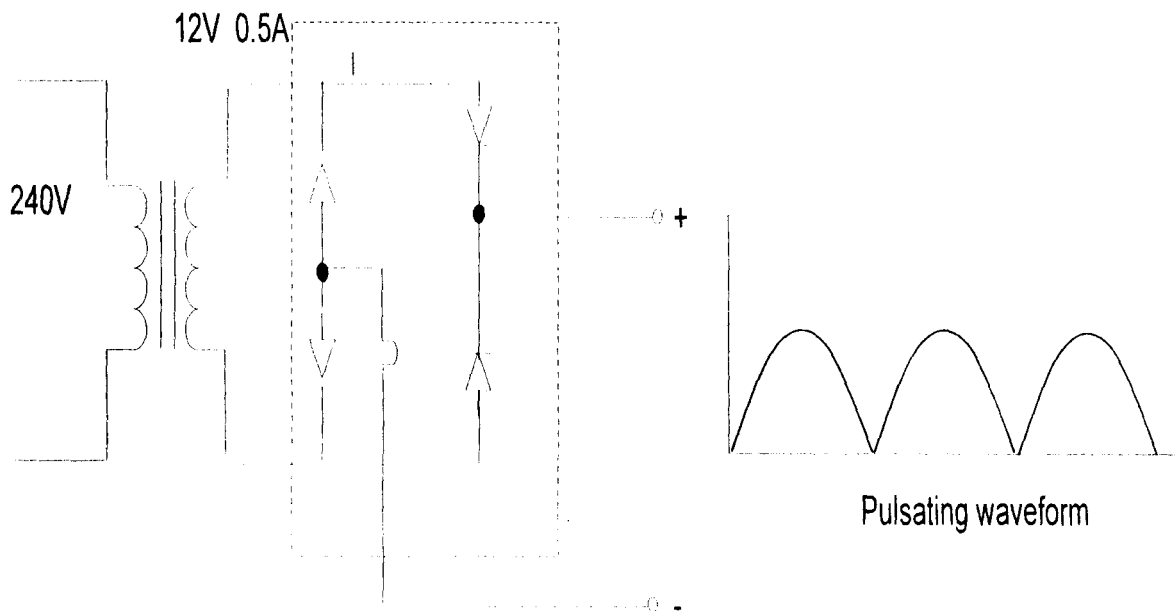

Fig3.1 AC-DC Converter

The DC output from the converter was observed as a pulsating wave-form with twice the line frequency i.e. a 100Hz waveform. A steady DC supply was needed hence a smoothening capacitor had to be connected to the rectifier.

For a $12V_{rms}$ secondary AC voltage, the peak DC output was;

$$V_{dc \text{ peak}} = (V_{rms} \sqrt{2} - 1.4) V$$

$$V_{dc \text{ peak}} = 12\sqrt{2} - 1.4 = 15.5V. [16]$$

The smoothening capacitance will be chosen to have a DC working voltage a minimum of 1.5 times greater than the expected peak DC voltage [11].

The value of smoothening of capacitance was decided by the relation. $Q = CV = It$.

Where V = maximum allowable AC ripple voltage on the DC output;

I = maximum load current;

t = period of the pulsating DC output

$t = 1/2F$; (FWR)-full wave rectifier

$= 1/F$; (HWR) half wave Rectifier.

F = main frequency = 50HZ (Nigeria).

A charging current of about 450mA was chosen for the back up battery. This value of current pre-dominated the equation above. For the battery charging system, a minimum input voltage of 8V was required, corresponding to a maximum peak-to-peak ripple voltage of 7.5V on the DC voltage. Substituting into the equation: -

$$C = \frac{It}{V}$$
$$= \frac{0.45 \times \frac{1}{2} \times 50}{7.5}$$

$$= \frac{0.45 \times 0.01}{7.5}$$

$$= \frac{4.5 \times 10^{-3}}{7.5}$$

$$= (0.6 \times 10^{-3}) \text{ F}$$

$$= 600 \mu\text{F}$$

The value of capacitance above was the minimum needed to meet the system requirements. This value was increased about 4-folds to improve system performance, and a value of $2200 \mu\text{F}$ capacitance, at a working voltage of 25V was selected [17].

3.3 BATTERY CHARGING SUBSYSTEM

A constant-current charging system was required for the incorporated lead acid battery. The charger was realized using a 3-pin Lm317T regulator and associated parts wired as shown below: [16]

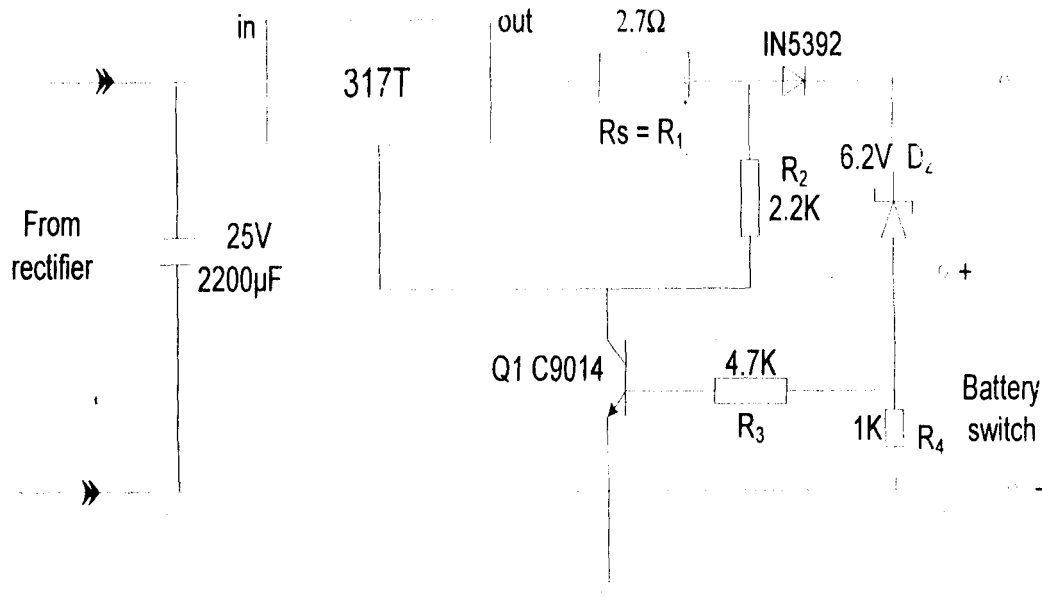

Fig3.2 Battery charger system

An adjustable regulator, LM317T was used. It was wired as a current regulator with the inclusion of a current-programming resistor in series with its output pin. This was connected to the adjust pin to complete the feedback loop necessary to maintain current regulation.

3.4 Analysis:

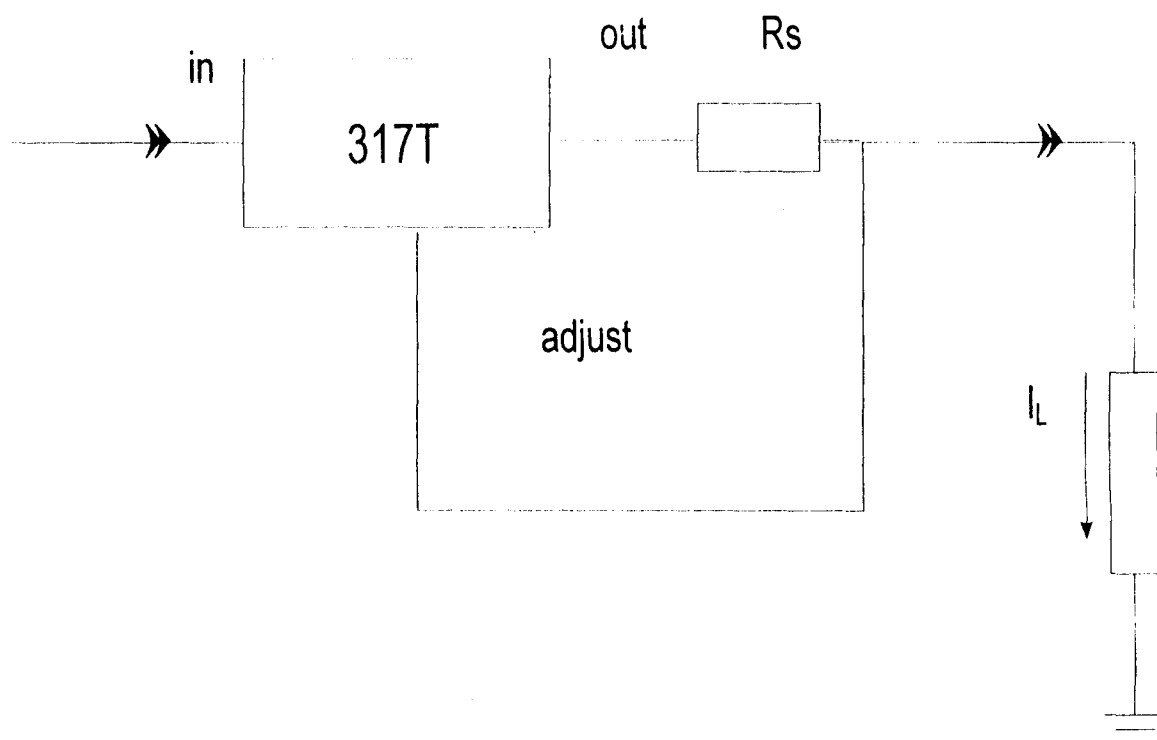

Fig3.3 Lm317T Current regulation

When configured as in fig 3.2 above, the Lm317T regulator fixes the maximum output [load] current at

$$I = \frac{V}{R}$$
$$= [1.25/R_s] \text{ A}$$

1.25 = an internal reference voltage in the LM317T

R_s value of resistance between the outputs adjust pin.

The device can source a maximum of 1.5A at low input-output differential voltages. For a lead acid battery, the maximum charging current is typically Ah/5 and the minimum Ah/20, where Ah is the ampere-hour capacity.

A 6V 4.5Ah battery was incorporated the minimum and maximum charging current is calculated as: -

$$I_{\text{charge (min)}} = 4.5\text{Ah}/20 = 2.25\text{mA}$$

$$I_{\text{charge (max)}} = 4.5\text{Ah}/5 = 0.9\text{A}$$

A modest 0.46A was selected. This demanded a longer charging time but improves the life expectancy of the battery since rapid charging is not a system requirement.

For a 0.46A charging current, R_s was calculated as: -

$$1.25/0.46 = 2.7\Omega$$

This value of resistance was incorporated in the current-programming feedback loop. The maximum battery terminal voltage was fixed at 6.9V. This was determined by the network shown below: -

a terminal voltage that is just sufficient to cause conduction in Q1. This terminal voltage is calculated using a V_{bc} of 0.7V.

$$0.7 = V_{\text{battery}} - V_z. \text{ (the zener is used as a subtractor here)}$$

$$V_z = 6.2V$$

$$0.7 = V_{\text{battery}} - 6.2V$$

$$V_{\text{battery}} = 6.9V$$

This is the battery maximum terminal voltage. The IN5392 diode prevents back discharge in the event of a mains failure.

3.5 LIGHT DETECTOR

An LDR (light dependent resistor) was used to sense the presence or absence of ambient light. It was wired in series with a resistor in a potential divider network and output voltage across the resistor conditioned by a 555 Schmitt trigger.[18]

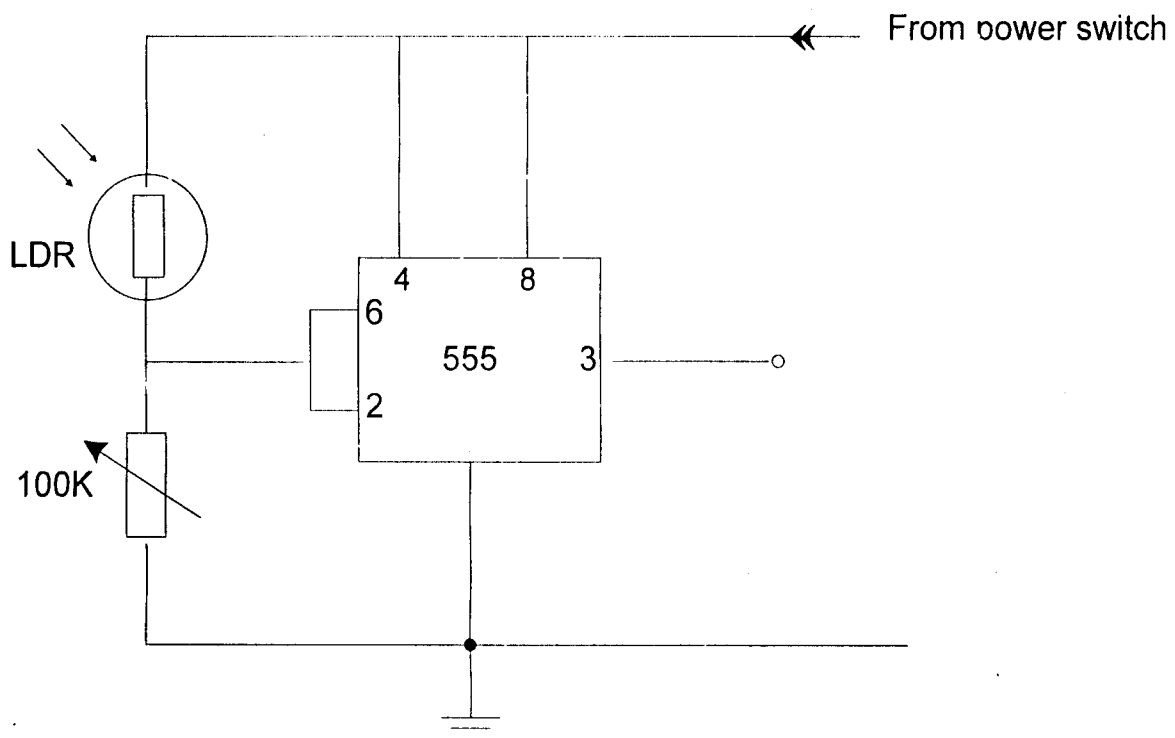

Fig 3.5 555 Schmitt Trigger

Configured as shown above, the 555 device operates as a Schmitt trigger with preset threshold [14]. A Schmitt trigger is a comparator with two separate trip points as compared to one for a standard comparator. For a Schmitt trigger, the switch points can be termed V_{upper} and V_{lower} .

For an input voltage $< V_{lower}$, the input transits to a known state, and remains in this state until the input voltage exceeds V_{lower} . At this point the output changes state.

This eliminates oscillations that intervene in simple comparator designs. For the 555, the upper switch threshold is fixed at $2/3V_{cc}$, and the lower at $1/3V_{cc}$.

For an input voltage (on pins 6 and 2) lesser than $1/3V_{cc}$ the output is higher and remains high until the input voltage exceeds $2/3V_{cc}$, when it switches low. Thus the 555 is an inverting Schmitt trigger. The voltage output derived from the LDR-resistor network was fed into pins 6 and 2 of the device. In the light, $V_{pins\ 6, 2}$ is high, and pin 3 (output pin) of the 555 is low. This low resets the HF oscillator and hence no frequency is generated. In the dark, $V_{pin\ (6, 2)}$ is low and pin 3 switches high [18]. The HF oscillator is enabled and a 40 KHz output frequency is powered and radiated over the ultrasonic transducer.

3.6 40 kHz HIGH FREQUENCY OSCILATOR

An NE 555 device was used to generate the 40KHz output needed to repel the insect.

It was configured for a stable operation as drawn below: -

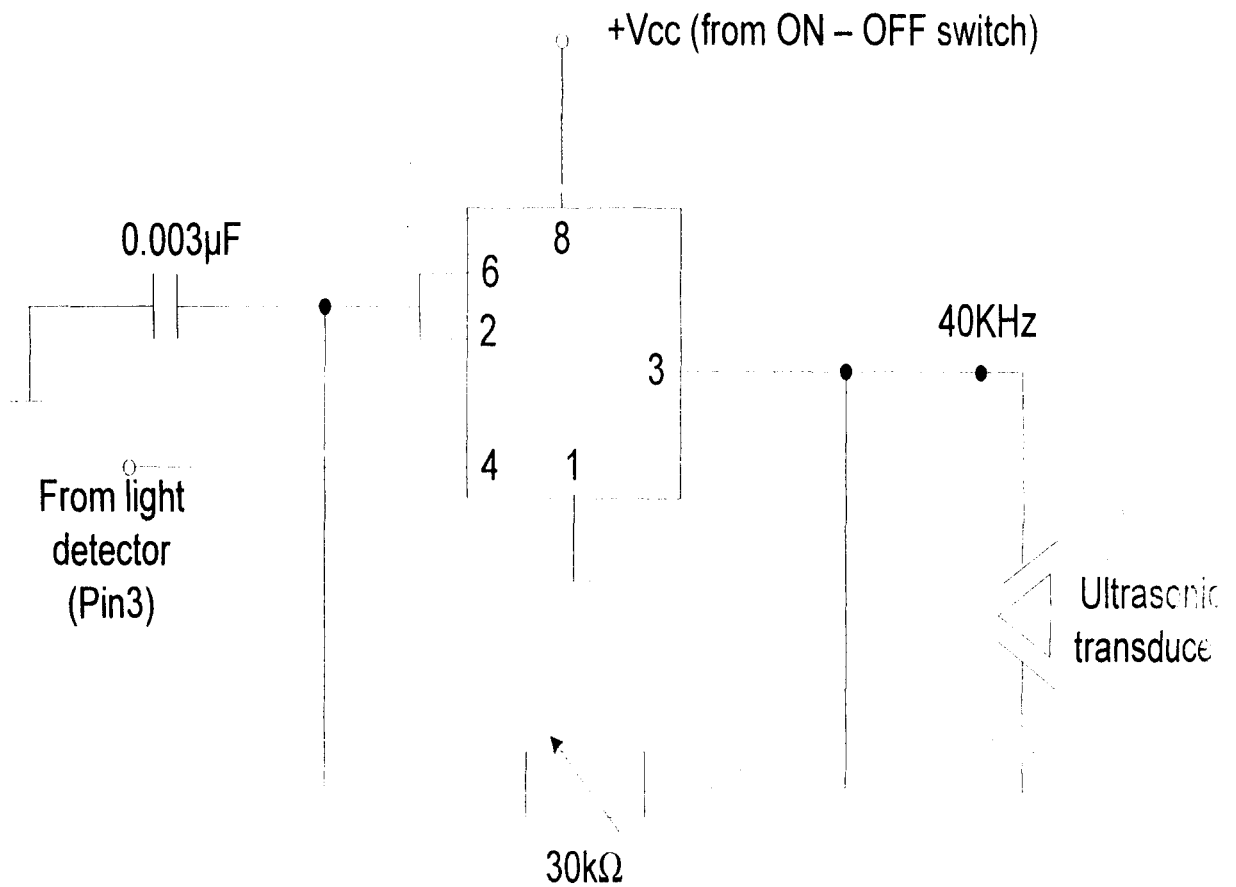

Fig 3.6 High Frequency oscillator

When configured as shown above, the 555 output a waveform with 50% duty cycle that is a square wave the frequency of oscillator is given by

$$F = (1/1.1RC) \text{ Hz.}$$

From the circuit above, the value of capacitor C used is 0.0033μf while the variable resistor R was tuned to 0.00688Ω. That is

$$C = 0.0033\mu\text{f}$$

$$R = 0.00688\Omega$$

Substituting the values of C and R into the equation

$$F=1/(1.1RC)$$

$$F = 1/(1.1 \times 0.00688 \times 0.0033)$$

$$F = 1/(0.0000249744)$$

$$F = 40 \text{ KHz}$$

Therefore, the output is generated by the rapid charging and discharging of the capacitor through pin 3 via the adjustable resistor [18]. It was made adjustable so that a fine adjustment of the output frequency could be made as ultrasonic radiators perform below normal when operated on frequencies that deviate substantially from their centre frequency.

HF generation is enabled when the output of the switch Schmitt goes high, and disabled otherwise. Hence, the presence or absence of ambient light can be used to start or stop the HF generation. However, a manual mode is provided to enable system operation at all times when the battery is not charged.

3.7 Complete Circuit Diagram of Uninterruptible Power Electronic Mosquito Repellent

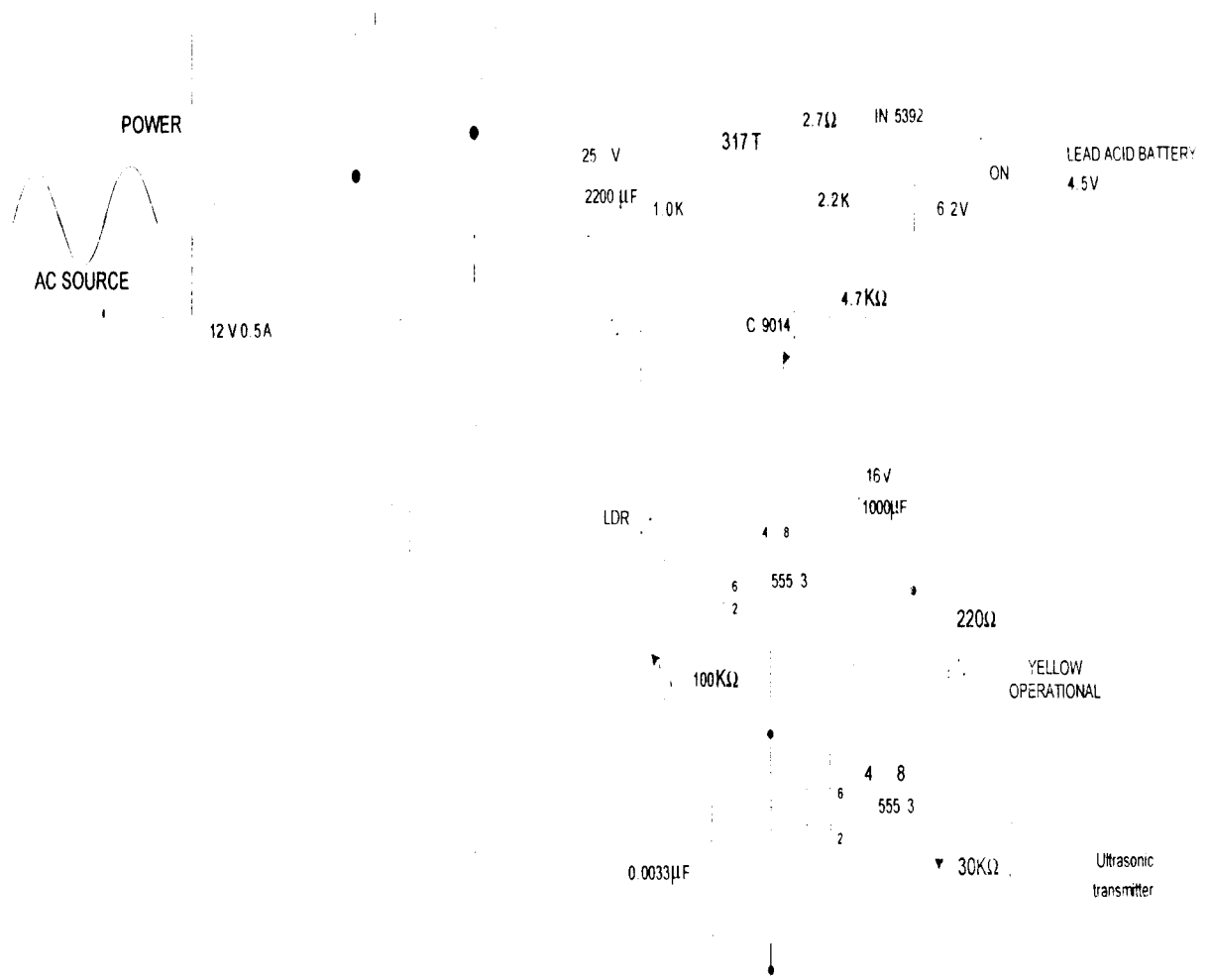

Fig 3.7 Diagram of Uninteruptible Power Electronic Mosquito Repellent

CHAPTER FOUR

4.0 CONSTRUCTION, OBSERVATION, TESTING, RESULT AND CASE

4.1 CONSTRUCTION

At this point the various components bought were soldered on a Vero board as shown in the circuit diagram. The soldering was done at interval i.e. stage by stage. Each stage was tested to see if it gave the desired output.

The step down transformer first mounted on the board and connected to the mains supply and its voltage measured with a multimeter. The output was observed to be 12v in the ac form which was fed to a silicon bridge rectifier which convert it to dc form.

The dc voltage so obtained was fed to a filter to remove the ripples in the circuit using a 100uf capacitor which was soldered on the Vero board. The 555 timer was wired as an ultrasonic circuit and was fed with +12v, the output signal of the timer was a square wave with a voltage level of approximately 8v. This was fed into the speaker through the output pin three coupled via a capacitor of 0.1uf. The ultrasonic sound generated was measured with a frequency counter and found to be within the range of calculated value.

4.2 OBSERVATION

The resistors, capacitors and diodes were all tested using a multimeter all were proved to be in good working condition on breadboard. They were consequently soldered permanently on a Vero board.

The transducer at the output generated an ultrasonic sound between 20 – 40 KHz. At this frequencies insects, birds and rodents are repelled.

Furthermore, the output of the waveform from an oscilloscope was a square wave. And also independent tests were carried out on the various sections to ensure that they were all in order before final coupling was done.

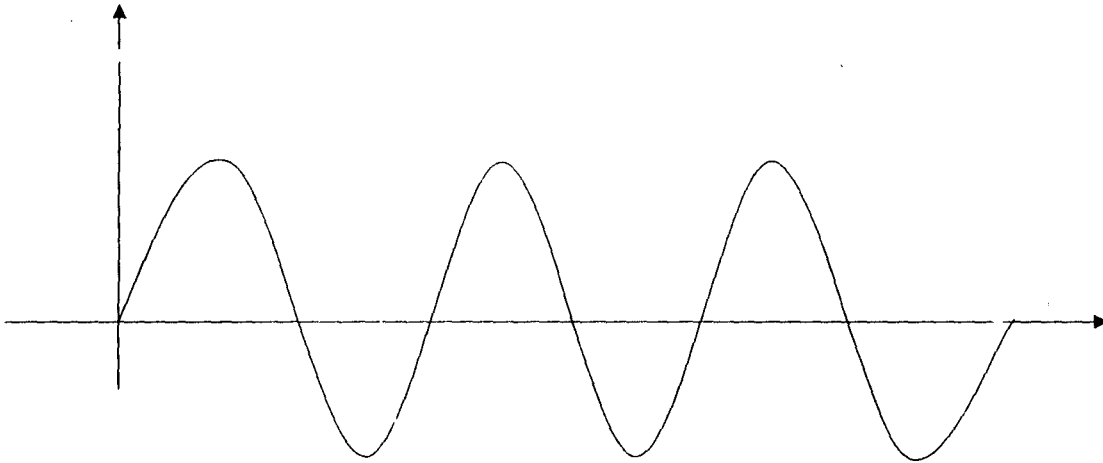

Figure 4.0: Ultrasonic sound wave from oscilloscope

4.3 TESTING

The following test was carried out after construction: -

1. Output frequency test. A frequency counter was used to test the output of the repeller circuit and was found to be 40 kHz.
2. Effect on mosquito (repeller action)

The circuit was taken to class and ON for about 30minutes, no mosquito came near me. It was also slept with in my room and no effect of mosquito was felt.

4.4 RESULT

The frequency output is 40 kHz after construction, there was no audible sound produced by the 4 ohm speaker but vibration was observed

4.5 CASE CONSTRUCTION

1. Type of casing: - a transparent plastic glass casing was used for the casing to prevent the components from being exposed to dust and to make it more hand able.
2. Dimensions; the dimension of the case is 8 x 9 x 19.
3. Diagram of case: -

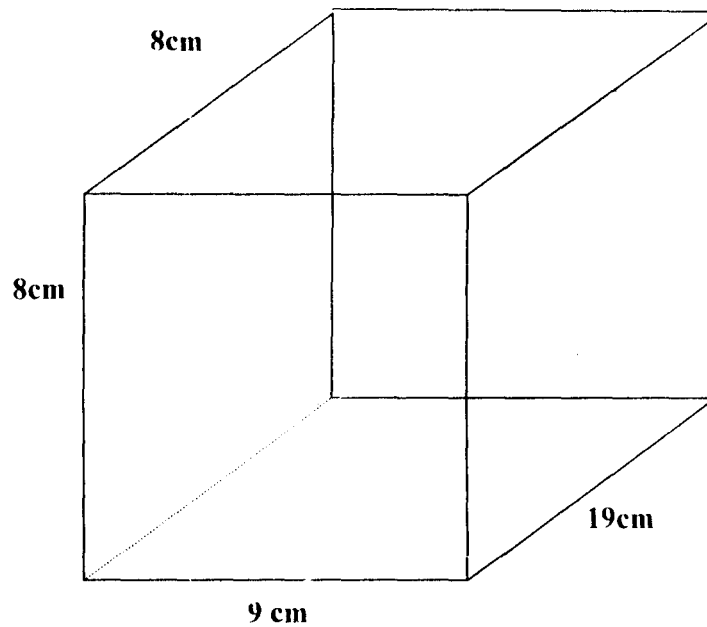

Figure 4.1: Casing dimension

4.6 PROBLEMS ENCOUNTERED

The construction was first done on a breadboard and during testing it was observed that the 555IC became hot after some minutes; also the vibration on the speaker was not observable.

4.7 SOLUTION PREFERRED

The transformer was giving out current of 0.5A, while the speaker needed about 0.9A of current. Because of this imbalance, some components were removed to balance the circuit and an amplifier transistor was used to amplify the vibration of the speaker.

CHAPTER FIVE

5.1 CONCLUSION

Malaria is transmitted by certain species of mosquito called Anopheles. Malaria is a major cause of infant mortality and is the only insect borne parasitic disease comparable with world's major diseases, diarrhea, acute respiratory infections, tuberculosis and AIDS.

Although malaria could be controlled through the use of malaria vaccines such as chloroquine, maloxine, fansidar, metacalfin and use of mosquito treated nets, but the "Guardian" of report says that malaria vaccines could create more virulent strains of malaria.

The mosquito repeller is a circuit constructed to repel female mosquitoes which bite. This circuit produces an ultrasonic sound at 40kHz which is the sound produced by the male mosquitoes which makes the female mosquito to stay away especially when they are pregnant in search of food. This ultrasonic sound at 40 kHz is not audible to human ears but can repel the female mosquitoes at a certain radius of 3m as designed. With this project, the problem of mosquitoes at homes, offices, schools, hospitals, e.t.c can be controlled.

This project has given me an insight on how 555timer can be used to generate ultrasonic sound frequency that scare away mosquitoes, this sound can be achieved by varying certain parameters in the circuit during design.

5.2 RECOMMENDATION

Although, this project has been designed to specification, there are one or two things that need to be incorporated into the design especially in the mosquito-repelling unit [15].

Finally, the mosquito repelling unit should be incorporated with a burning filament that can produce enough heat to react with little oxygen to produce carbon (iv) oxide, and also a sucks ion tubule to suck attracted mosquitoes into an enclosure.

Secondly, also the power system should be provided with a re-chargeable system to be able to charge the battery.

REFERENCES

- [1] JOURNAL WATCH EMERGENCY MEDINE Mosquito bite.
- [2] Blessing Enoch Ubah, Mosquito repeller. Federal University of Technology, Minna, 2005. Pp 1-3.
- [3] www.fbake/y.com/idea
- [4] Okpala FidelisChibuzo (1998): Design and Construction of ultrasonic mosquito and pest repellent. Unpublished project work, Electrical/Computer Engineering, Federal University of Technology, Minna
- [5] Hickman, C. J. Pr. Biology of animals, Department of Biology, Washington and Lee University, Lesington, Virginia, PP181, 318 – 319, 451.
- [6] Anene Ifechukwude M (2004): Design and construction of an ultrasonic pest repellent. Unpublished project work, Electrical/Computer Engineering, Federal University of Technology, Minna.
- [7] www.mosquitocycle.com
- [8] www.jamestownnd.com/vector control/a
- [9] Simon Adewale Bolorunduro (2006): "Design and construction of a variable frequency ultrasonic pest repellent." Physics/Electronics Department, Federal University of Technology, Minna.
- [10] Beyer, Rober T. "Ultrasonic" Microsoft Encarta. New Scoophysic by M. Y. ANYAKOHA, Ph.D. p. 266 & 325.
- [11] Edwards J. D., Electrical machines and drives, published by Macmillan Education Limited, printed in Hong Kong, 1991, Pp 84 – 86.
- [12] Dr. D. W. Ewer, formerly professor of zoology, University of Ghana and J. B. Hall, Department of Biology, University of Ghana. Ecology biology2, Longman house, Burnt mill, Harlow, Essex, 1978, Pp 214 and 329.
- [13] Oladejobi Adewale (2005): "Design and construction of an ultrasonic mosquito and pest repellent." Unpublished project work, Physics/Electronics Department, Federal University of Technology, Minna.
- [14] Charles A. (1999): Electronics Principles and Applications. Glenco/MacGraw Hill, U. S. A. Pp. 350 – 353.
- [15] Journal watch Emergency medicine, August 1, 1998; 1998 (801); 22 – 22 (full text).

- [16] R. I. Theraja & A. K. Theraja. Textbook on Electrical Technology in S. I. Unit, printed in India, S. Chand & Company Ltd.
- [17] Len Jone, Basic electronics for tomorrow's world, 1993, Pp. 40 – 80.