

# **COMPUTER AIDED DESIGN OF AN AMBULANCE SIREN**

**BY**

**JOSEPH OSHEIZA ATURETA  
2004/18793EE**

**A THESIS SUBMITTED TO THE DEPARTMENT OF  
ELECTRICAL AND COMPUTER ENGINEERING IN PARTIAL  
FULFILLMENT OF THE REQUIREMENT FOR THE AWARD  
OF BACHELOR OF ENGINEERING (B.ENG)  
SCHOOL OF ENGINEERING AND ENGINEERING  
TECHNOLOGY, FEDERAL UNIVERSITY OF TECHNOLOGY,  
MINNA, NIGER STATE.**

**DECEMBER, 2009**

## DECLARATION

I hereby declare that this project was undertaken and documented by me as a result of intense research work. It has not been presented before for any certificate, degree or diploma at any Institution. Information derived from personal communications, published and unpublished works of others are duly referenced in the text.



Joseph O. Atureta

2004/18793EE

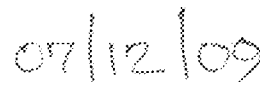

Date

## DEDICATION

This project is dedicated to my Parents Mr and Mrs Atureta for all their support and encouragement throughout my education and for all their prayers.

## CERTIFICATION

This is to certify that this project work is being written and documented by Joseph O. Atureta, with Matriculation Number 2004/18793EE and has not been submitted by anybody for any purpose. It therefore meets the requirement governing the award of (B.Eng) degree honours in Electrical and Computer Engineering.



Prof. O. Osifo

4-2-10

Date



Dr. Y.A. Adediran

May 6, 2010

Date

External Examiner

Date

## ACKNOWLEDGEMENTS

I give praise to God to who is the source of my strength, understanding and wisdom upon seeing me through the completion of this project work and my first degree academic pursuit.

My appreciation goes to my supervisor, Prof. O. Usifor whose hard work in impacting knowledge, project guidance and good supervision made this project work easier for me. I also wish to appreciate my Head of Department, Engr. Dr. Y.A. Adediran for also impacting knowledge to me right from second year till date including all the other lectures in the Department of Electrical and Computer Engineering and also other lectures in the institution who have imparted knowledge to me during my academic years.

Also I want to thank my parents Mr and Mrs J.A. Atureta for their moral and financial support throughout my academic years, may they reap the fruit of their labour. To my siblings who have also given me their moral and financial support in their own way, I say thank you and appreciate the love and care we show in the family, may God continue to bless us.

Finally I want to thank my friends, colleagues and well wishers who have supported me such as Seun Adetoye(Presido), Moshood A.Lawal(Big Mosh), Onome C. Osagada(Mourinho), Adide S.Emelis(Sammy), Adejoh W. Monday(Dejo), Richard A. Dauda(Richoo), Jahswill A. Teru(Jahdon) and to those not mentioned please don't take it personal but you are all most appreciated.

## ABSTRACT

This project, "computer aided design of an ambulance siren" is an electronic device mounted on ambulance vehicles to produce a sound as a warning signal to alert the public in cases of emergencies.

The ambulance siren consists of electronic components such as one of the family of IC which is the 555 timer, capacitors, a.c supply (rectifier) and transducer (loudspeaker) which are assembled and interconnected to generate an oscillating signal.

The 555timer IC which is connected in an astable mode to generate an oscillating signal at the output of the first 555timer IC which is used to trigger the second 555timer IC and resulting output is transformed into continuous sound with uniform frequency. The oscillating signal at the output of the 555timer is then amplified to give a sound similar to that of an ambulance siren.

## LIST OF FIGURES

Figure		Page
2.1	The Internal Structure of 555 IC timer	7
2.2	Actual Pin Configuration of 555 timer	8
2.3 a	A Step Down Transformer	12
2.3b	A Circuit Symbol of a step down transformer	13
2.4	Loudspeaker and its longitudinal section	14
2.5	Astable circuit mode of 555 timer	15
2.6	Monostable circuit mode of 555 timer	17
2.7	Bistable circuit mode of 555 timer	18
2.8	Buffer circuit of 555 timer	19
3.1	Power supply Unit of the siren	21
3.2	The alarm stage of the siren	23
3.3	The Amplification Unit	24
3.4a	Oscillator circuit for the first 555 timer	25
3.4b	Oscillator circuit for the Second 555 timer	27
3.5	The Circuit Diagram of an ambulance siren	30

# TABLE OF CONTENTS

Title page	i
Declaration	ii
Certification	iii
Dedication	iv
Acknowledgements	v
Abstract	vi
List of Figures	vii
Table of Contents	viii

## CHAPTER ONE

1.0 INTRODUCTION	1
1.1 Background to the Project	1
1.2 Discovery of the Project	2
1.3 Significance of the Project	2
1.4 Aims and Objectives of the Project	3
1.5 Justification of the Project	3

## CHAPTER TWO

2.0 LITERATURE REVIEW	5
2.1 Category of Siren Design	6
2.1.1 Pneumatic Siren	6
2.1.2 Electronic Siren	6



2.2	Circulatory Components	7
2.2.1	IC 555 timer	7
2.2.2	Definition of Pin Functions	9
2.2.3	Transformer	11
2.2.4	Diode	13
2.2.5	Loud Speaker	13
2.2.6	Resistors	14
2.3	Mode of Operation	14
2.3.1	Astable Oscillator	15
2.3.2	Monostable Oscillator	17
2.3.3	Bistable Oscillator	18
2.4.4	Buffer Oscillator	18

## CHAPTER THREE

3.0	<b>DESIGN AND IMPLEMENTATION</b>	<b>20</b>
3.1	Principle of the Design	20
3.1.1	Power Supply Stage	20
3.1.2	The Alarm Stage	23
3.1.3	The Amplification Unit	24
3.2	Design Calculations	25
3.3	The Entire Circuit Diagram	30

## **CHAPTER FOUR**

<b>4.0</b>	<b>CONSTRUCTION AND TESTING</b>	<b>31</b>
4.1	Construction Tools and Materials	31
4.2	Construction Precaution	32
4.3	Problems Encountered	33
4.5	Testing and Results	33

## **CHAPTER FIVE**

<b>5.0</b>	<b>CONCLUSION AND RECOMMENDATION</b>	<b>34</b>
5.1	Conclusion	34
5.2	Recommendation	34
	<b>References</b>	<b>35</b>

# CHAPTER ONE

## 1.0 INTRODUCTION

### 1.1 Background to the Project

The ambulance emergency services today, in some ways, are like military force that are organized and discipline. They are an official organization empowered to saves lives through first aid treatment before patients are being taken to the hospital. Effectiveness in carrying out these indispensable responsibilities will require some basic amenities such as an ambulance vehicle with a siren. The siren attached to the ambulance is a very vital equipment to alert the public indicating an emergency situation thereby clearing traffic to get to the nearing hospital for medical attention. Sirens also alert victims of accidents the arrival of medical help coming to their aid which could be a lifeline to victims on the verge of losing all hope.

This project consist of electronic components such as one of the family of IC which is the 555 timer, a step down transformer, capacitors, resistors, diode (A.C supply rectifiers), light emitting diodes (LED) and an output transducers (loudspeaker) which are assembled and interconnected to generate and oscillating signal.

This electronic project uses 555 timers to generate a sound similar to ambulance siren. The principle of its operation involves the connection of the 555 timer in an astable multivibration mode which involves the output of the first IC fed into the input of the other IC through a reasonable valued resistor.

## **1.2 Discovery of the Project**

The 555 timer integrated circuit is one of the commonest and readily available IC that has different kinds of applications such as pulse generation, precise timing, sequential timing, timing delay generation and pulse width modulation (PWM). It has very wide application which can be found in almost all electronic circuits.

Its characteristics to generate signal which were caused to pass through appropriate electronic circuit compartment to obtain the desired wave than produce siren effect make it interesting to study. The 555 timer with just a few components can be used to build many circuits not all of them involve timing. Siren is a device that makes a loud sound as a signal or warning. The needs for siren are highly required at this present generation to enhance the security level in an environment. It is therefore required to design a police siren from cheap and available electronic components.

Designing a siren thus, involves a study between its need to customize the sound and the necessity of providing appropriate signals.

The noise siren is almost continuous which makes everybody to understand why and how it is made or done. Manufacturers of siren have made it louder, more penetrating and more painful to ignore. It is therefore required to study and design using less component provided the desired sound is more penetrating and reasonable.

## **1.3 Significance of the Project**

Everybody responds to all kinds of emergency calls regardless of the nature with sirens. The main function of a siren thus, involves a study between the needs to customize sounds and the necessity of producing appropriate warning signal.

An ambulance siren in itself alerts the public of the arrival of an ambulance not to be confused with a police siren or a fire brigade siren. Siren attached to a vehicle is essential to alert other vehicles in cases of emergency. It also makes vehicles position noticeable to oncoming motorists and pedestrians and creates room in terms of traffic. Sirens are not only used by ambulances but also other personnel such as police, fire brigade and others. The design of an ambulance siren is undertaken because of the cheap electronic components and available materials to present similar sounds and signals.

#### **1.4 Aims and Objectives**

The aims of this project are:

- To show the application of 555 timer IC
- To show how the 555 timer IC can be used to produce tones similar to that of an ambulance siren
- To show how an ambulance siren can be designed from available and cheap components to reduce the cost and work effectively and efficiently.

#### **1.5 Justification of the Project**

Sirens are very useful especially in the developed countries where it is being fully utilized because it gives warning and indicates the level of security in an environment. It alerts the general public by catching their attentions. The sirens are not only used by ambulances but also by some organizations listed below:

- Traffic Emergency Patrol.
- Immigration Service Vehicles.

- Red Cross Vehicles. (Used for urgent blood deliveries)
- Custom Service Vehicles.
- Mine Rescue Vehicles.
- Operational Fire Brigade Vehicles.

Sirens attached to any one of these emergency vehicles may emit one or more of the following siren sounds:

- An alternating heehaw sound.
- A continuous wailing sound.
- An urgent, repeated whooping sound.

Drivers of emergency service vehicles often select different siren sounds to suit prevailing traffic situations. The fitting of sirens is strictly prohibited on vehicles other than emergency vehicles specified above.

## CHAPTER TWO

### 2.0 LITERATURE REVIEW

The invention of ambulance siren relates in general to a means and a method of alerting the public of an emergency situation present by producing an audible sound as a signal or warning.

Some time before 1799, the first siren was invented by the Scottish natural philosopher (physicist) called John Robison. Robison's sirens were used as musical instruments; it consisted of a stopcock that opened and closed a pneumatic tube. The stopcock was apparently driven by the rotation of a wheel. In 1819, an improved siren was invented and named by Baron Charles Cagniard de la tour. De la tour's siren consisted of two perforated disks that were mounted coaxially at the outlet of a pneumatic tube. One disk was stationary, while the other disk rotated. The rotating disk periodically interrupted the flow of air from the fixed disk, producing a tone.

The first sound of siren was publicly heard during the World War II on 3<sup>rd</sup> September, 1939. Before the Second World War, the siren has been used as a way of summoning volunteers or meeting. Sometimes, a bell is placed or mounted at the top of fire station or in the belfry of a local church to notify or indicate any emergency events.

As electricity became available, the first sirens were manufactured. Two early manufacturers of sirens were Federal Signal Cooperation and Sterling Siren. Both started manufactured fired siren around 1900 to 1905. These fire sirens were mounted near government buildings, on top of the tall structures such as water towers, where several sirens are sporadically placed around a town for a better sound coverage.

## **2.1 CATEGORY OF SIREN DESIGN**

There are many types of siren produced which can all be categorized into two major types which are the pneumatic and electronic sirens.

### **2.1.1 Pneumatic Siren**

The pneumatic siren consists of rotating disk with holes in it (called a rotor or siren disk), such that materials between the holes interrupt the flow of air into the fixed holes on the outside of the unit called a stator. As the holes in the rotary disk alternatively prevents and allows air to flow, it results in alternating compressed and rarefied air pressure i.e. sound. This type of siren consume large amount of energy. It is referred to as mechanical or coastal sirens, to differentiate them from devices which produced noise electronically. One example is Q2B electromechanical siren sound by Federal Signal Corporation. It has distinct tone of urgency sound power (123dB) and square sound wave for its effectiveness.

### **2.1.2 Electronic Sirens**

Electronic sirens incorporate circuit such as oscillator, modulators and amplifiers to synthesize a selected siren tone which is placed through external speakers. This is the type of siren commonly used by ambulances, police, fire brigade etc. Other types like steam whistles were also used as a warning device if a supply of steam was present, such as sawmill or factory. These were common before fire sirens became widely available. Fire horns and large compressed air horns were also used as an alternative to fire sirens.



## 2.2 CIRCUITRY COMPONENTS

### 2.2.1 IC 555timer

The 555 timer is the most remarkable integrated circuit ever developed. It consists of two voltage comparator, a bi-stable flip flop, a discharge transistor and a resistor divider network.

The IC has 8 pin configuration which are shown below showing the internal structure.

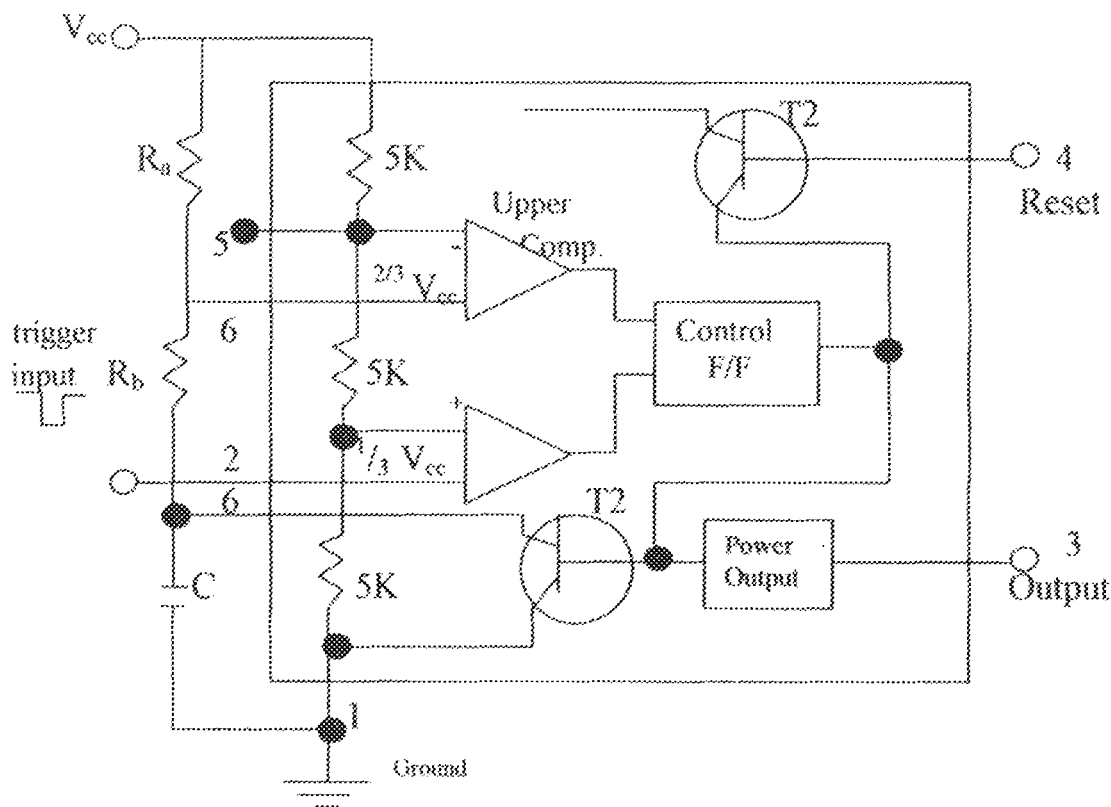

Fig 2.1 The internal structure of the 555 IC timer

The internal resistors  $r_a$ ,  $r_b$  and  $r_c$  acts as voltage divider, providing bias voltage of  $2/3V_{cc}$  to the upper comparator and  $1/3V_{cc}$  to the lower comparator where  $V_{cc}$  is the supply voltage. It is recommended by manufacturers that a capacitor be connected

between control voltage terminal (pin 5) and ground to by pass noise or ripple from the supply.

In the standby state, the output of the control flip flop is high. This makes the output low because of power amplifier which is basically an inverter. A negative power trigger pulse is applied at pin 2 and should have its level greater than the threshold level of the lower comparator (i.e.  $V_{cc}/3$ ) the output to the lower comparator goes high and sets the flip flop.

During the positive excursion, when the threshold voltage at pin 6 passes through  $2/3$  the output of the upper comparator goes high and resets the flip flop ( $Q=0, \bar{Q}=1$ ). The RESET input (Pin 4) provides a mechanism to reset the flip flop in a manner which overrides the effect of any instruction coming from the lower comparator. The overriding reset the effectiveness when the reset input is less than  $0.4V_{cc}$ . When the reset is not used, it returns to  $V_{cc}$ .

The transistor  $Q_2$  serves as a buffer to isolate reset input from the flip flop, transistor  $Q_2$  driven by an internal reference voltage  $V_{ref}$  obtained from the supply voltage.

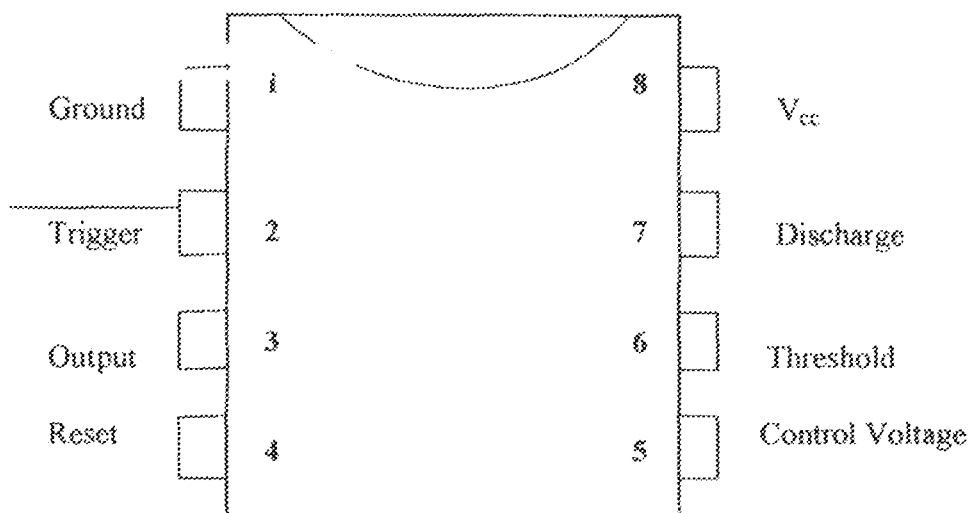

Fig 2.2 Actual Pin configuration of 555 timer

### 2.2.2 Definition of Pin Functions:

**Pin 1 (Ground):** The ground (or common) pin is the most negative supply potential of the device, which is normally connected to circuit common (ground) when operated from positive supply voltages.

**Pin 2 (Trigger):** This pin is the input to the lower comparator and is used to set the latch which in turn causes the output to go high. This is the beginning of the timing sequence in monostable operation. Triggering is accomplished by taking the pin from above to below a voltage level of  $1/3 V+$  (or in general, one half the voltage appearing at pin 5). The action of trigger input is level sensitive, allowing slow rate of change waveforms, as well as pulses, to be used as trigger sources. The trigger pulse must be of shorter duration than the time interval determined by the external R and C. If this pin is held low longer than that, the output will remain high until the trigger input is driven high again. One precaution that should be observed with the trigger input signal is that it must not remain lower than  $1/3V+$  for a period of time longer than the timing cycle. Another precaution with respect to the trigger input concerns storage time in the lower comparator.

**Pin 3 (Output):** The output of the 555 timer comes from a high current capable to provide drive for source type loads, and their Darlington connection provides a high state

output voltage about 1.7 volts less than the  $V^+$  supply level used. It could also provide current sinking capability for low state loads referred to  $V^+$  (such as typical TTL inputs). The output voltage available at this pin is approximately equal to the  $V_{cc}$  applied to pin 8 minus 1.7V.

**Pin 4 (Reset):** This pin is also used to reset the latch and return the output to a low state. The reset voltage threshold level is 0.7 volt, and a sink current of 0.1mA from this pin is required to reset the device. These levels are relatively independent of operating  $V^+$  level; thus the reset input is TTL compatible for any supply voltage. The reset input is an overriding function; that is, it will force the output to a low state regardless of the state of either of the other inputs. It may thus be used to terminate an output pulse prematurely, to gate oscillations from "on" to "off" etc.

**Pin 5 (Control Voltage):** This pin allows direct access to the  $2/3V^+$  voltage divider point, the reference level for the upper comparator. It also allows indirect access to the lower comparator. Use of this terminal is the option of the user, but it does allow extreme flexibility by permitting modification of the timing period, resetting of the comparator etc. When the 555 timer is used in a voltage controlled mode, its voltage controlled mode, its voltage controlled operation ranges from about 1 volt to less than  $V^+$  down to 2 volts of ground (although this is not guaranteed). Voltages can be safely applied outside this limit, but they should be confined within the limits of  $V^+$  and ground for reliability. By applying a voltage to this pin, it is possible to vary the timing of the device independently of the RC network.

**Pin 7 (Discharge):** This pin is connected to the open collector of a NPN transistor; the emitter of which goes to ground, so that when the transistor is turned "on", pin 7 is effectively shorted to ground. Usually the timing capacitor is connected between pin 7 and ground and is discharged when the transistor turns "on". The conduction state of this transistor is identical in timing to that of the output stage. It is "on" (low resistance to ground) when the output is low and "off" (high resistance to ground) when the output is high.

**Pin 8 (V+):** The V+ pin (also referred to as  $V_{cc}$ ) is the positive supply voltage terminal of the 555 timer IC. Supply voltage operating range for the 555 timer is +4.5 volts (minimum) to +16 volts (maximum), and it is specified for operations between +5 volts and +15 volts. The device will operate essentially the same over this range of voltages without change in timing period. Sensitivity of time interval to supply voltage change is low, typically 0.1% per volt. There are special and military devices available that operate at voltages as high as 18volts.

### 2.2.3 Transformer

Transformer is a device that transfers electrical energy from one circuit to another through a magnetic field. It converts AC power at a certain voltage to AC power at a different voltage level with the same frequency, a change in current in the primary circuit creates a change in the magnetic field and this in turn generates a voltage in the secondary by induction.

Transformer operation makes use of mutual induction in which when one coil of wire which is connected to an AC source is placed near a second coil or wire which as a

result of line of force from the primary cut across the windings of the secondary coil and voltage is induced. It therefore serves as a device that transfers electrical energy from one circuit to another, through a shared magnetic field.

The transformer has at least two windings of wire placed near one another. The two windings are physically insulated from one another but magnetic flux lines mutually couple the two windings together.

Voltage transformers can be classified into two basic types which are:

- Step Up Transformer
- Step Down Transformer

When the number of turns in the secondary is greater than the number of turns in the primary, then we say it is a step up voltage transformer and when the number of turns in the primary is greater than the number of turns in the secondary, it is said to be a step down voltage transformer. A step down transformer was used in the process of converting ac voltage to a dc voltage to first lower the ac voltage to a considerable level for power supply stability.

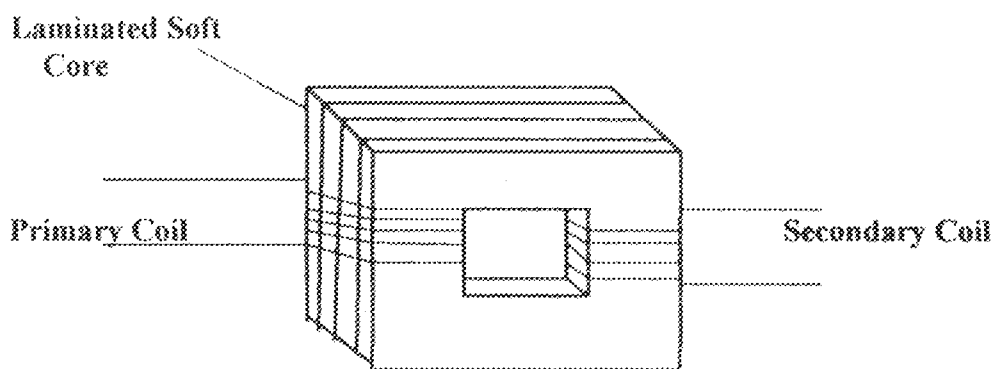

Fig 2.3a A Step down Transformer

The circuit symbol is also as shown below:

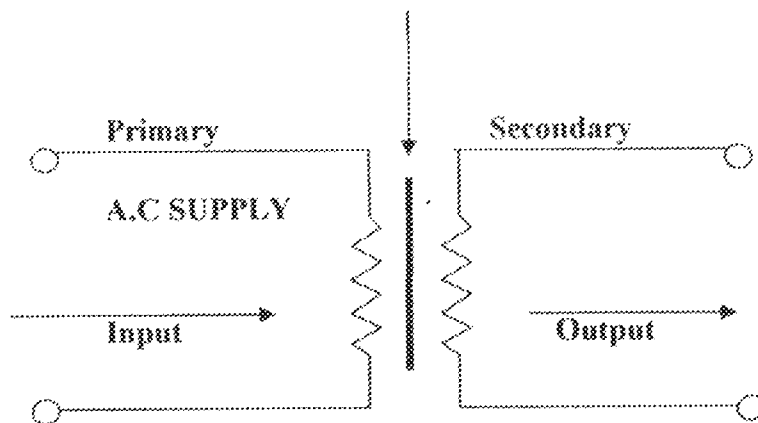

Fig 2.3b A Circuit Symbol of a step down transformer

#### 2.2.4 Diode

A diode is an electronic semi conductor device which offers low resistance to current moving in a certain direction through it and prevents the flow of current in the reversed direction. It is usually made up of either silicon or germanium which have been alloyed or doped with quantities of a chosen impurity. According to the impurity chosen, they are classed as either p-type or n-type where the letter p stands for positive and n stands for negative respectively. A junction diode consists of a single crystal of material, one half being p-type and the other n-type.

#### 2.2.5 Loudspeaker

A loudspeaker function is to convert electrical signal to speech/audio sounds i.e. form electrical energy to sound energy. It uses a permanent magnet and a moving coil to produce the vibrational motion that generates the pressure waver we perceive as sound. This vibration is caused by changes in the input current to a coil; the coil is in turn coupled to a magnetic structure that can produce time varying force on the speakers'

diaphragm. They are generally low impedance transducers that are very sensitive to the electrical signals coming from the power amplifier.

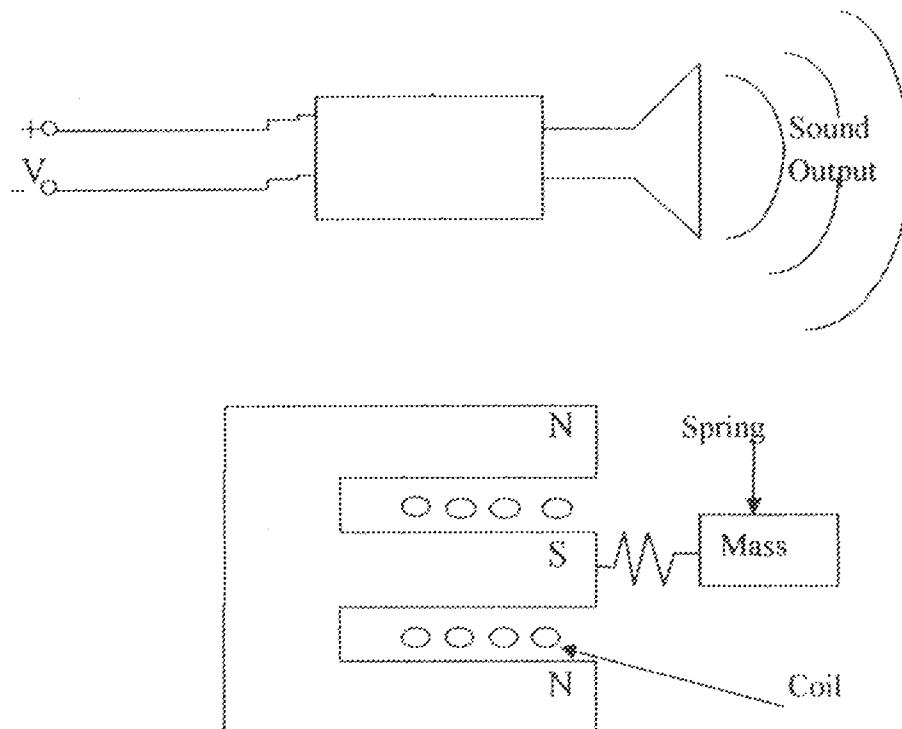

Fig 2.4 Loudspeaker and its longitudinal section

### 2.2.6 Resistors

Resistors are either used to control the current in the electronic circuit to divide up the voltage (Potential Divider) or to convert charging current in the output of a system into a corresponding charge in the voltage.

## 2.3 MODE OF OPERATION

The 555 timer must be one of the most useful IC's ever made and it is used in many circuit designs. It can be operated in different modes of operation which include the following:

- i. Astable Oscillator



- ii. Monostable Oscillator
- iii. Bistable Oscillator
- iv. Buffer Oscillator

### 2.3.1 Astable Oscillator:

An astable circuit produces a "square wave", this is a digital waveform with sharp transitions between low (0 volts) and high ( $+V_s$ ). The duration of the low and high states may be different. The circuit is called an astable because it is not stable in any state: the output is continually changing between 'low' and 'high'. The circuit below shows the astable mode of 555 timer.

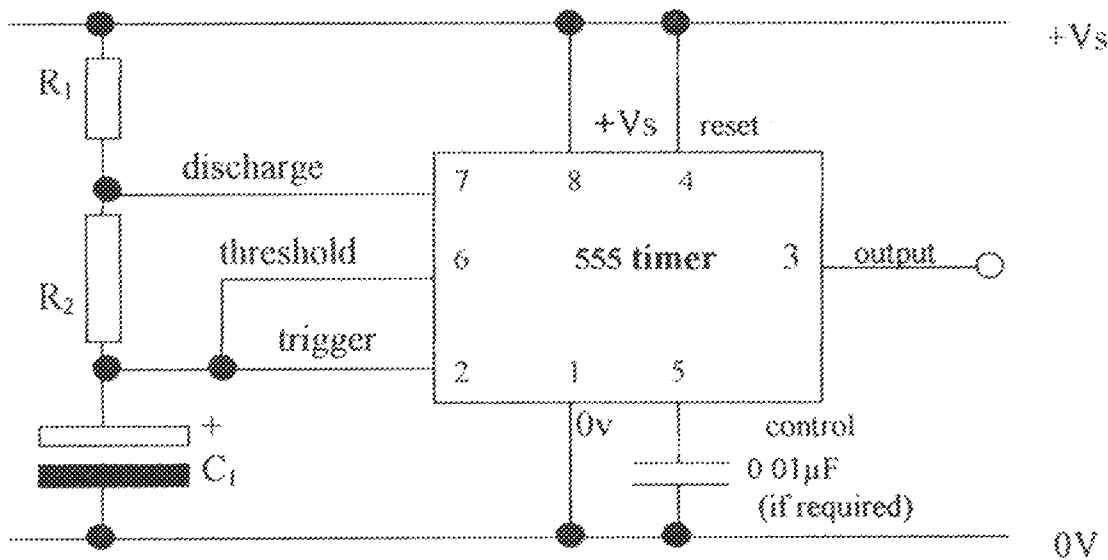

Fig 2.5 An Astable circuit mode of a 555 timer

The operation is such that with the output high (+Vs), the capacitor C<sub>1</sub> is charged by current flowing through R<sub>1</sub> and R<sub>2</sub>. The threshold and trigger inputs monitor the capacitor voltage and when it reaches 2/3 Vs (threshold voltage), the output becomes low and the discharge pin is connected to 0V. The capacitor now discharges with current flowing through R<sub>2</sub> into the discharge pin. When the voltage falls to 1/3 Vs (trigger voltage) the output becomes high again and the discharge pin is disconnected, allowing the capacitor to start charging again.

The time period (T) of the square wave is the time for one complete cycle, but it is usually better to consider frequency (f) which is the number of cycles per second.

$$T = 0.7 \times (R_1 + 2R_2) \times C_1 \text{ and}$$

$$f = \frac{1.4}{(R_1 + 2R_2) \times C_1}$$

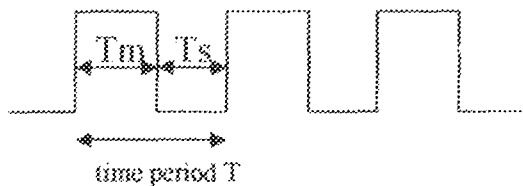

T = time period in seconds (s)

f = frequency in hertz (Hz)

R<sub>1</sub> = R<sub>2</sub> = resistance in ohms (Ω)

C<sub>1</sub> = capacitor in farads (F)

The time period can be split into two parts,

$$T = T_1 + T_2$$

Mark time (Output high). T<sub>1</sub> = (R<sub>1</sub> + 2R<sub>2</sub>) × C<sub>1</sub>

Space time (Output Low):  $T_2 = 0.7 \times R_2 \times C_1$

### 2.3.2 Monostable Oscillator:

A monostable circuit produces a single output pulse when triggered. It is called a monostable because it is suitable in just one state, 'output low'. The 'output high' state is temporary.

The duration of the pulse is called the time period (T) and this is determined by resistor  $R_1$  and capacitor  $C_1$ :

$$\text{time period, } T = 1.1 \times R_1 \times C_1$$

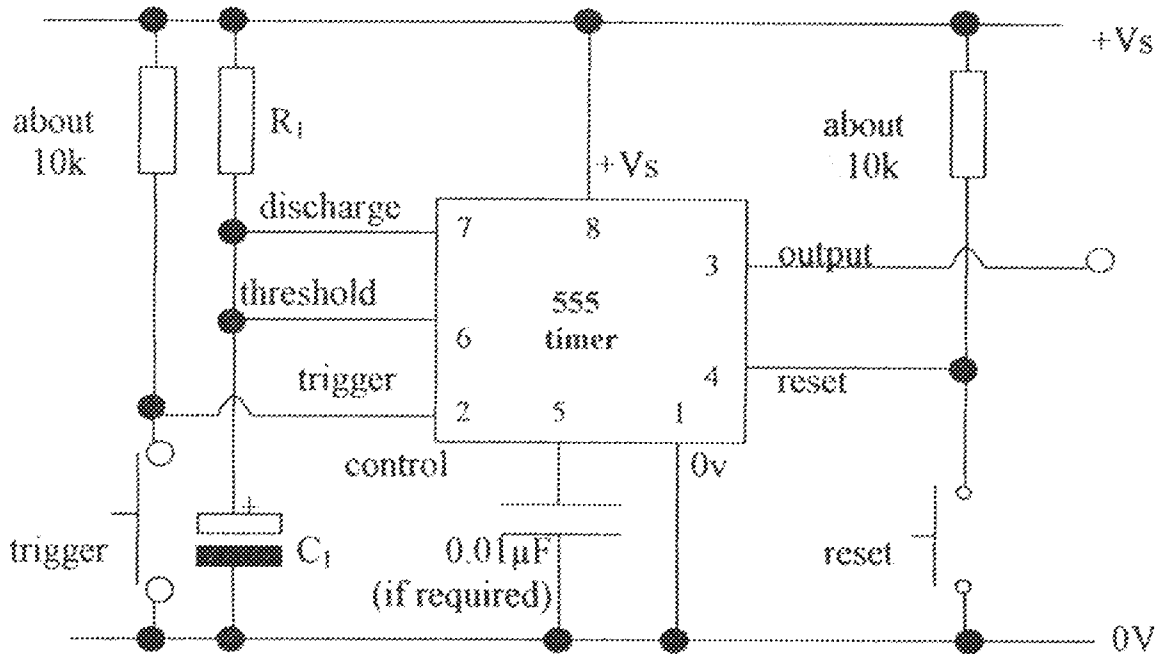

Fig 2.6 A Monostable mode of a 555 timer

### 2.3.3 Bistable Oscillator:

This is used as a simple memory which can be set and reset. The circuit is called a bistable because it is stable in **two** states: "output high" and "output low". It is also called a 'flip flop' and has two inputs:

- Trigger (555 pin 2) makes the **output high**. Trigger is 'active low', it functions when  $< 1/3 V_s$
- Reset (555 pin 4) makes the **output low**. Reset is 'active low', it resets when  $< 0.7V$ .

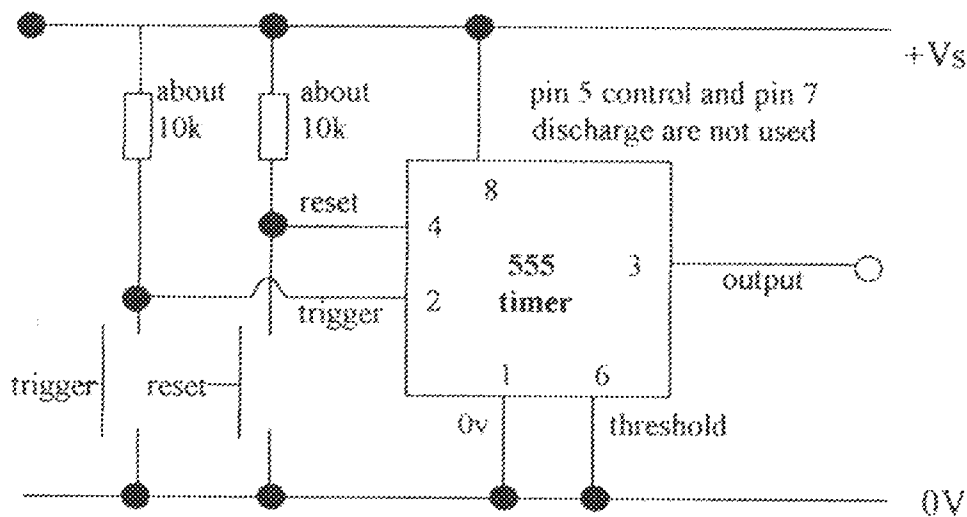

Fig 2.7 Bistable circuit mode of 555 timer

### 2.3.4 Buffer Oscillator:

The buffer circuit's input has a very high impedance (about  $1M\Omega$ ) so it requires only a few  $\mu A$ , but the output can sink or source up to 200mA. This

enables a high impedance signal source (such as an LDR) to switch a low impedance output transducer (such as a lamp).

It is an **inverting buffer** or NOT gate because the output logic state (low/high) is the inverse of the input state. The buffer oscillation circuit is as shown below,

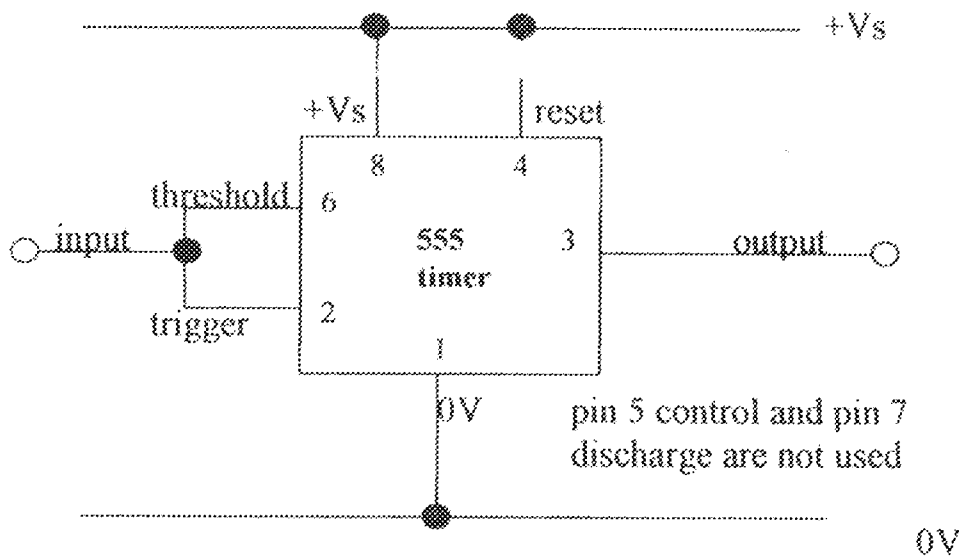

Fig 2.8 The Buffer circuit of 555 timer

## CHAPTER THREE

### 3.0 DESIGN AND IMPLEMENTATION

#### 3.1 Principles of the Design

The analysis of the design of an ambulance siren is dependent solely on the modulating capacity of the 555 timer IC. The generation of two different frequencies was involved; a low frequency is first generated for modulation and the other which is a high frequency for tone generation. Each time the modulating frequency enters the control voltage input (i.e. pin 5), the frequency of the tone generator changes and creates a different tone. The output is fed to the speaker through a coupling capacitor to get the tone output in the speaker. Passing the output of the timers through a power amplifier increases the output power gain.

The design and construction of an ambulance siren alarm with an external source or with a battery is based on three main stages or units. Each Unit is described in detail with respect to the components level.

The main sub-units are:

1. Power Supply Unit/Battery Unit.
2. Alarm Stage Unit.
3. The amplification Unit.

#### 3.1.1 Power Supply Stage

The power supply used is gotten directly from the mains and alternatively from a DC battery. All electronic systems requires energy to work. The power supply unit provides this electrical energy. In the case of using a regulated power supply that

provides a 9V, the power supply is a linear power type and involves a step-down transformer, filter capacitor and voltage regulators. These components are incorporated to give the various voltage levels. The power supply circuit diagram is shown in figure below:

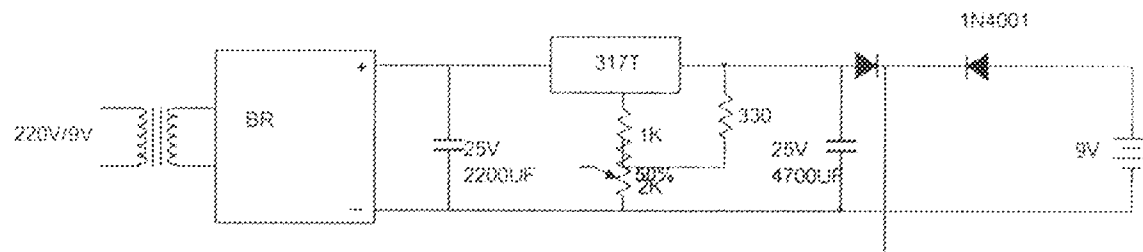

Fig 3.1 The Power Supply Unit of the Siren

The power supply unit for this project was designed to provide 9V (d.c battery) for the alarm unit. The transformer used, has an input voltage of 240V a.c at 50Hz and an output voltage of 12V a.c at 500mA. The rectifier unit consists of a bridge rectifier which rectifies the output of the transformer to a pulsating d.c voltage output.

A filtering capacitor filters the output of the bridge rectifier to a pure d.c voltage. A 317T voltage regulator is used to stabilize the output voltage exactly 9V. This d.c voltage is used to power the entire circuits. The normal a.c mains supply is meant to be of 240v rating. However, in order to give room for minor fluctuations that range from 6% of this, fluctuation as low as 140V and as high as 340V the transformer turns ratio must be such that the minimum amount of supply voltage to the system is maintained. In this case, the unit which contains the 555 timer requires a minimum of 3V to 18V maximum. The step down transformer produces an output of 9V when the supply from the a.c mains is 240V.

The choice of the filter capacitor is dependent on the output current.

Given that;

$$V_r (\text{rms}) = \frac{2.4 I_L}{C_1} \dots\dots\dots (i)$$

Where  $V_r (\text{rms})$  = Rectified D.C Ripple voltage

$I_L$  = Load Current (mA)

$C_1$  = Filter Capacitor

For a Load Current of a 500mA and a ripple factor of 5%

$$\begin{aligned} V_{\text{rms}} &= V_{\text{peak}} \times \sqrt{2} \\ &= 9\text{V} \times \sqrt{2} \\ &= 12.69\text{V} \end{aligned}$$

For a ripple of 5%

$$\begin{aligned} V_r (\text{rms}) &= \frac{5}{100} \times 12.69 \\ &= 0.6345 \end{aligned}$$

From (i)

$$0.6345\text{V} = \frac{2.4 \times 500 \text{ mA}}{C_1}$$

$$C_1 = \frac{2.4 \times 500 \text{ mA}}{0.6345}$$

$$= 1891.25\mu\text{F}$$

$$= 2200 \mu\text{F preferred value}$$

Hence,  $C_1 = 2200 \mu\text{F}$ .



### 3.1.2 The alarm stage

The alarm circuit diagram is as shown in the figure below

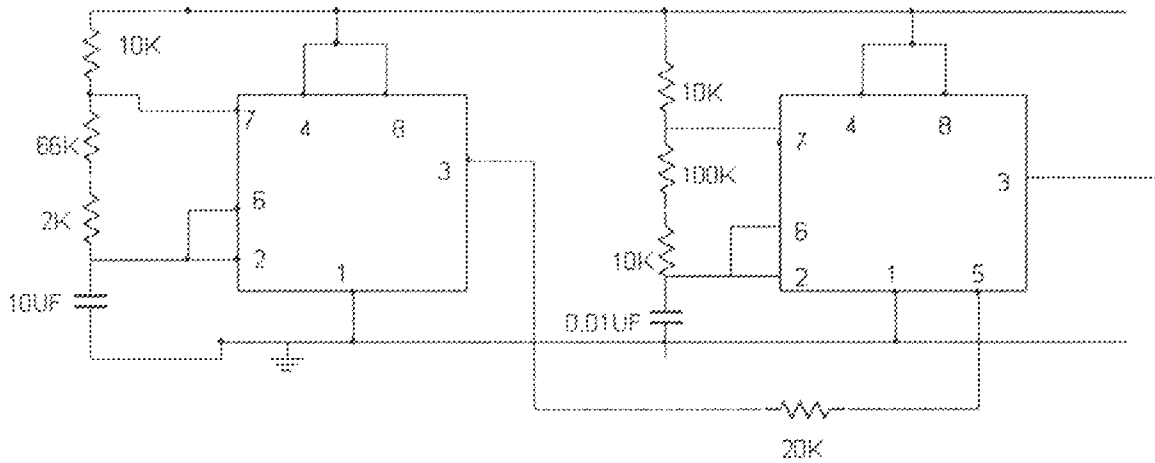

Fig 3.2 The Alarm Stage of the siren

The circuit above illustrates the alarm stage of the ambulance siren system. This is the next stage after the rectification of the input a.c voltage to d.c voltage. In this stage the two 555 timer are cascaded in such a way that the output of the first is use as the input of the second. The working principle in this stage is that when the output of the first 555 timer is high, current flows through the resistor  $R_1$  and  $R_2$  while the capacitor starts to charge, the threshold and trigger inputs monitor the capacitor voltage and when it reaches  $2/3 V_s$  (threshold voltage), the output becomes low and the discharge pin is connected to 0V. The capacitor now discharges with the current flowing through  $R_2$  into the discharge pin. When the voltage falls to  $1/3 V_s$  (trigger voltage) the output becomes high again and

the discharge pin is disconnected, allowing the capacitor to start charging again. The output is then fed into the second 555 timer to trigger it. The same operation is performed in the second 555 timer to give the resulting oscillating signal. The capacitor  $C_5$  and  $C_6$  which are  $47\mu\text{F}$  each, are connected to prevent the unwanted oscillating signals.

### 3.1.3 AMPLIFICATION UNIT

The output of the astable multivibrator needed to be amplified for higher gain. A power transistor is used in this project so that the gain output will be high. It should be noted that the blocking capacitor is employed to block direct current and allow the little a.c to pass. Therefore a.c signals of low power loss are said to have higher gain than d.c. The blocking capacitor could also serve the purpose of removing unwanted oscillating signals. The circuit representation of this unit is as shown below:

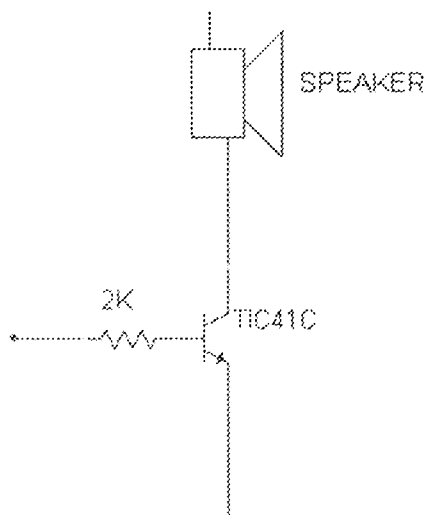

Fig 3.3 The Amplification Unit

### 3.2 DESIGN CALCULATION

The design calculation of this project was done with a considerable value of the duty cycle in such a way that the mark time ( $T_m$ ) i.e. the time ON must be greater than the space time ( $T_s$ ) i.e. the time OFF, so the duty cycle must be at least 50%. However, the duty cycle of an astable circuit is the proportion of the complete cycle for which the output is high (the mark time). It is usually given as a percentage.

$$\text{Duty Cycle} = \frac{T_m}{T_m + T_s} = \frac{R_1 + R_2}{R_1 + 2R_2}$$

The oscillator circuit diagram for generating an ambulance tone for the first IC is as shown in figure below:

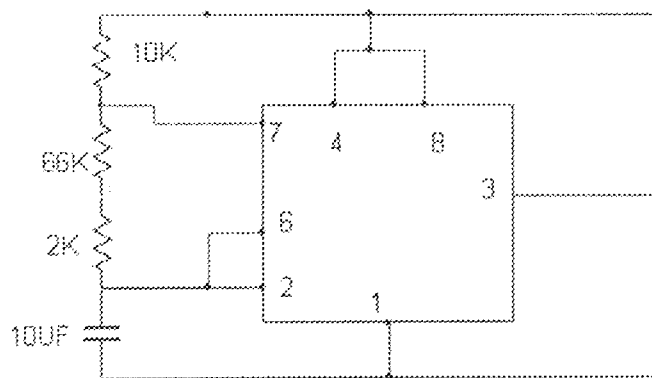

Fig 3.4a Oscillator circuit for the first 555 timer

$$\text{The frequency of oscillation } F = \frac{1.44}{(R_1 + 2R_2)C_1}$$

$$= \frac{1.44}{(66+2 \times 2) \times 10^3 \times 10 \times 10^{-6}}$$

$$= \frac{1.44}{70 \times 10^3 \times 10 \times 10^{-6}}$$

$$= \frac{1.44}{70 \times 10^3 \times 0.00001}$$

$$= \frac{1.44}{0.7}$$

$$= 2.05714 \text{ Hz}$$

The output time is obtained as

$$t_1 = 0.693 (R_1 + R_2) C_1$$

$$= 0.693 (66 \times 10^3 + 2 \times 10^3) 10 \times 10^{-6}$$

$$= 0.693 (68000) 0.00001$$

$$= 0.47124 \text{ sec}$$

$$t_2 = 0.693 R_1 C_1$$

$$= 0.693 (66 \times 10^3 \times 10 \times 10^{-6})$$

$$= 0.45738 \text{ sec}$$

Therefore,

The total time of oscillation

$$T = t_1 + t_2$$

$$= 0.47124 + 0.45738$$

$$= 0.92862 \text{ sec.}$$

The duty cycle is given as  $\frac{R1+R2}{R1+2R2} \times 100\%$

Therefore, duty cycle =  $\frac{66+2}{66+2 \times 2} \times 100\%$

$$= \frac{68}{70} \times 100\%$$

$$= 97.12$$

The oscillator circuit diagram for generating an ambulance tone for the second 555 timer is as shown in figure below:

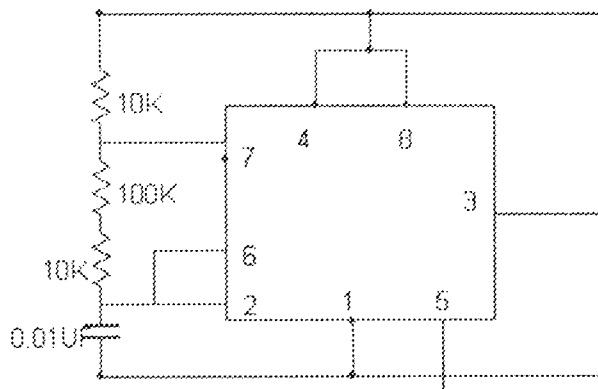

Fig 3.4b Oscillator circuit for the second 555 timer

The frequency of oscillation  $F = \frac{1.44}{(R1+2R2)C1}$

$$= \frac{1.44}{(100+2 \times 10) \times 10^3 \times 0.01 \times 10^{-6}}$$

$$= \frac{1.44}{2000 \times 10^3 \times 0.01 \times 10^{-6}}$$

$$= \frac{1.44}{2000 \times 10^3 \times 0.00000001}$$

$$= \frac{1.44}{0.02}$$

$$= 72\text{Hz}$$

The output time is obtained as

$$t_1 = 0.693 (R_1 + R_2) C_1$$

$$= 0.693 (100 \times 10^3 + 10 \times 10^3) 0.01 \times 10^{-6}$$

$$= 0.693 (110000) 0.00000001$$

$$= 0.0007623 \text{ sec}$$

$$t_2 = 0.693 R_1 C_1$$

$$= 0.693 (100 \times 10^3 \times 10 \times 10^{-6})$$

$$= 0.693 (100000 \times 0.00001)$$

$$= 0.693 \text{ sec}$$

Therefore,

The total time of oscillation

$$T = t_1 + t_2$$

$$= 0.0007623 + 0.693$$

$$= 0.69376 \text{ sec}$$

The duty cycle is given as  $\frac{R_1 + R_2}{R_1 + 2R_2} \times 100\%$

$$\text{Therefore, duty cycle} = \frac{100 + 10}{100 + 2 \times 10} \times 100\%$$

$$= \frac{110}{120} \times 100\%$$

$$= 91.67$$

## THE ENTIRE CIRCUIT DIAGRAM

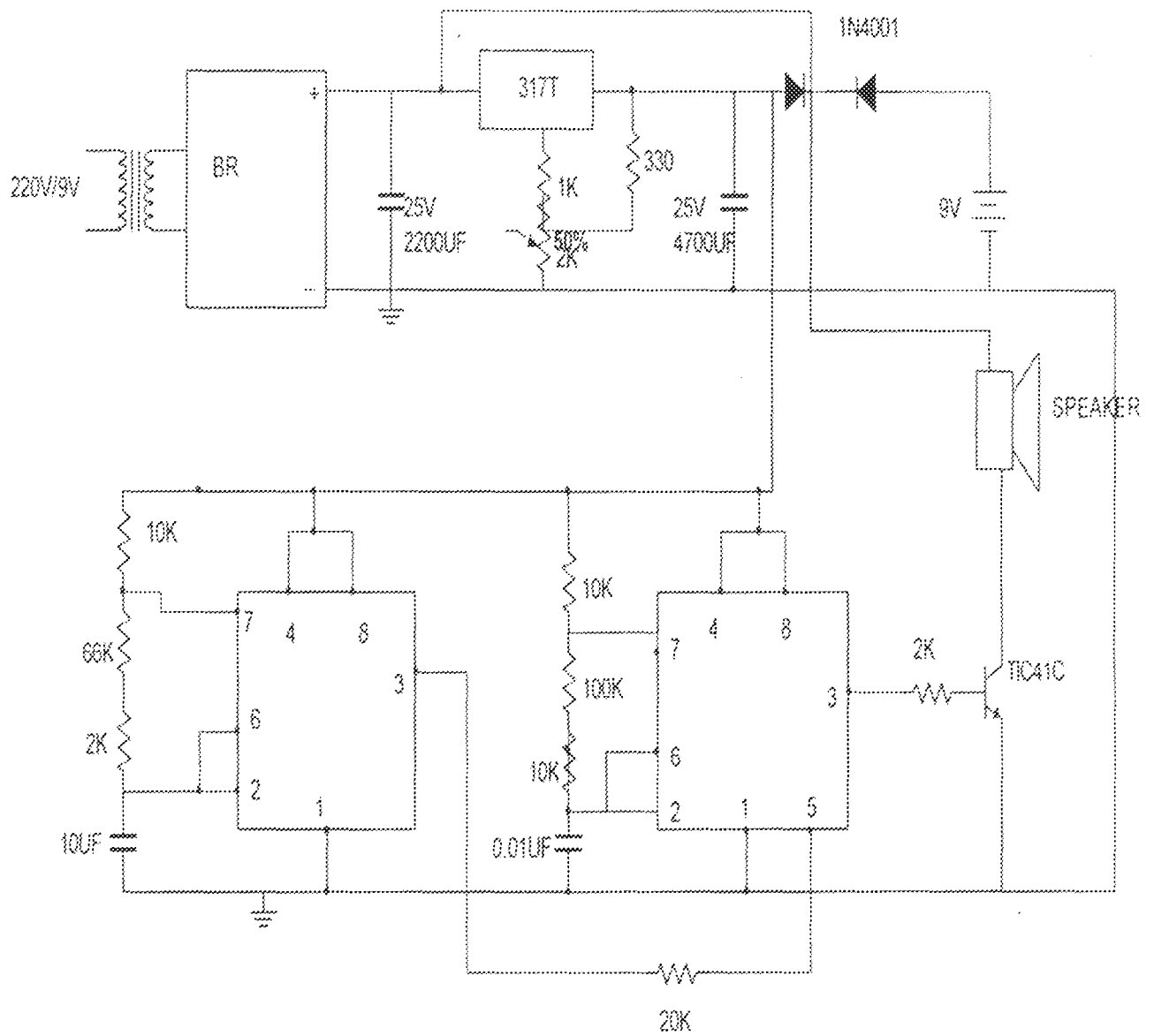

Fig 3.5 The Circuit Diagram of an Ambulance Siren



## CHAPTER FOUR

### 4.0 CONSTRUCTION AND TESTING

#### 4.1 Construction Tools and Materials

The tools and materials as well as instrument used during the testing and construction of this project are briefly described below.

**MultiSim:** Multisim is a computer application produced by National Instruments Electronic workbench group which specialize in applications that aids electrical designs to be able to carry out and test the workability of an electrical design before it is finally constructed.

**The breadboard:** This is a temporary board for circuit testing with tiny sockets that allows for electric components (e.g. resistors, capacitors, diode and transistors etc) to be easily connected or disconnected freely without damaging the component. The breadboard is meant for pre construction testing of circuit and sub units before the components are soldered on the veroboard.

**The veroboard:** This is a perforated board on which electronic components are inserted and soldered permanently. It is used for permanent construction of the proto-type from the circuit diagram.

**The analogue/digital multimeter:** These were devices (instruments) used for measurement of electrical quantities such as resistance, voltage and current. They are also capable of being used to test circuit sections for continuity. The digital multimeter gives a digital output display of measured quantities while analogue meters give an indication of

the value of measured quantities on a scale, the value of which is used on the position of the pointer on the scale.

**Wires and Connectors:** Wires are used during the testing stage of the project on the breadboard to connect the components together as well as the different sub units of the circuits, as well as during the soldering of the components on breadboard. The type of wire used is the copper wire.

**Soldering Iron:** this is a low power heating element typically 40 watts. It provides the heat needed to melt the lead, so that it can be used for the connection of the components permanently on the veroboard. It usually connected to the A.C mains.

- i. Soldering Lead: This is a metal (lead) wire of low melting point. It is used to electrically connect components and wire in fixed positions on the veroboard.
- ii. Lead Sucker: This is to suck off excess molten lead from the veroboard to prevent short circuit (bridging) or undesirable electrical connections.
- iii. Wire cutters/strippers: These tools are sue to cut wires to desired size required before use and to strip off insulation of the wire in order to expose the conductor for proper and neat soldering

## 4.2 CONSTRUCTION PRECAUTION

Polarities of the electrolytic capacitors and LEDs were properly checked to be correctly positioned before connecting (soldering) on the veroboard. All soldered points were tested for continuity so as to avoid unnecessary open circuits. All the excess leads were removed to avoid bridge (short circuit) on the boards. Excessive

heating of the components was avoided so that they don't burn by making the soldering process to a component very brief.

### **4.3 PROBLEMS ENCOUNTERED**

Several problems were encountered during the project ranging from the design problems to implementation problems and construction problems. Some of the major problems are as follows:

1. Short circuit of the ground and the V+, this resulted in the heating up of the 555 timer ICs, but the digital multimeter was used to tackle this problem by testing for continuity.
2. Soldering and measurement errors were encountered but were solved by proper troubleshooting and being careful in the construction of the project.
3. The exact calculated value for the components was gotten but these drifts were negligible since they were within range.

### **4.1.4 TESTING AND RESULTS**

After all the components were arranged on the breadboard, they were tested to ensure the required output. The components and connecting wires which were soldered were tested for continuity. The soldering joints were properly checked and errors detected were corrected by appropriate soldering and de-soldering actions. Hence, the overall conceptualization, design, building and testing becomes materialized and the desired result is the computer aided design of an ambulance siren was satisfactorily achieved.

## **CHAPTER FIVE**

### **CONCLUSION AND RECOMMENDATION**

#### **5.1 CONCLUSION**

This project is a prototype of an ambulance siren. The project is working according to the simulation and specified design. The ambulance siren helps solve problems because it gives warning and indicates the level of security and emergency in an environment

#### **5.2 RECOMMENDATION**

For a more sensitive, efficient and functioning system, the public should be made to be aware of sirens and be able to differentiate between one siren and another to prevent a state of chaos, accidents and unnecessary pandemonium.