

**DESIGN AND CONSTRUCTION OF A THERMOSTATIC
CONTROL FOR HEATING SYSTEMS**

BY

ERHUEH CHARLES IRIKFE

98/6962EE

**DEPARTMENT OF ELECTRICAL/COMPUTER ENGINEERING
SCHOOL OF ENGINEERING AND ENGINEERING TECHNOLOGY
FEDERAL UNIVERSITY OF TECHNOLOGY, MINNA
NIGER STATE, NIGERIA.**

NOVEMBER, 2004.

**DESIGN AND CONSTRUCTION OF A THERMOSTATIC
CONTROL FOR HEATING SYSTEMS**

BY

ERHUEH CHARLES IRIKFE

REG.NO: 98/6962EE

**DEPARTMENT OF ELECTRICAL/COMPUTER ENGINEERING
SCHOOL OF ENGINEERING AND ENGINEERING TECHNOLOGY
FEDERAL UNIVERSITY OF TECHNOLOGY, MINNA
NIGER STATE, NIGERIA.**

**A PROJECT REPORT SUBMITTED FOR THE AWARD OF
BACHELOR OF ENGINEERING (B.ENG.) DEGREE IN THE
DEPARTMENT OF ELECTRICAL/COMPUTER ENGINEERING.**

NOVEMBER, 2004.

DECLARATION

I ERHUEH CHARLES IRIKFE do declare that this project report is an original concept designed, constructed and modeled by me under the supervision and guidance of my supervisor, Engr. M.S Ahmed.

Information obtained from unpublished and published work of others acknowledged in accordance has been

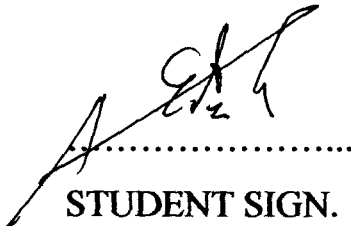
.....
STUDENT SIGN.

2/12/04
.....
DATE

CERTIFICATION

This is to certify that this project “thermostatic control for heating systems” was totally designed and constructed by ERHUEH CHARLES IRIKFE for the award of bachelor degree in Electrical/Computer Engineering; Federal University of Technology, Minna Niger State, Nigeria.

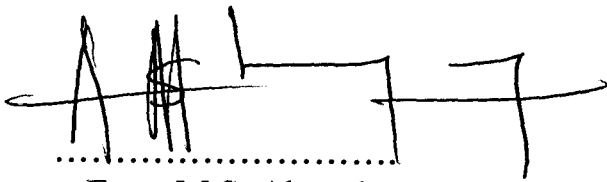

Engr. M.S. Ahmed
PROJECT SUPERVISOR

7/12/04
DATE



Engr. M.D. Abdullahi
HEAD OF DEPARTMENT

7/12/04
DATE

.....
EXTERNAL EXAMINER

.....
DATE

DEDICATION

This project report is dedicated to God Almighty for His immense work in my life.

ACKNOWLEDGEMENT

I wish to use this medium to express my profound gratitude to my supervisor, Engr. M.S. Ahmed, his tireless assistance, constructive ideas, encouragement and time spent. Also, special thanks goes to my lecturers, Engr.S.Abraham for his advice, Engr.P.Attah who gave me basic knowledge on analogue electronics, Engr. S. Rumula who gave me the basic background on control engineering and of course Engr. M.S Ahmed for the knowledge impacted on us on advanced circuit theory.

I also thank the present and past Head of department, Engr.Musa D.Abdullahi, Engr. Y.A. Adediran respectively for their fatherly advice to us. Special thanks to the Dean of Engineering Prof. F. Akinbode and to every member of Electrical/Computer Engineering department and the school at large for their efforts and encouragement for me during the course of my study.

I will be much indebted if failed to mention my uncles Rev.Msgr. Anthony. O.Erhueh, Mr. F.K Erhueh, Dr. P.W.M. Erhueh, Mr. Austin Erhueh and my only aunty Mrs. Theresa Ukre - umukoro for their supports during my study in school. Thanks also to my mentor Mr. Efemena.F. Elutabe, bros. your kindness will forever linger in my heart.

I wish to express my deep appreciation and gratitude to my brothers and sisters Mr. Joseph .E. Erhueh, Mr.Peter Erhueh,Engr. Ovie Erhueh,

Mrs. Helen O., Mrs. Ejiro. Terkumbi, Madam Grace, Efe Erhueh, Moses Erhueh, Tega Erhueh, Sarah Erhueh, Oke Erhueh, Edirin Erhueh, Oghenekowho Erhueh, Joy Erhueh, Elohor Erhueh, and to my very special friend Ehimen S. Uduebor for their encouragement and support during the course of my academic pursuit.

My regard goes to my colleagues Oduwole Opeyemi, Francis Chwang, Charity Atuegwu, Kolawole Olarinwaju, Adedayo Owonye, Mohammend Akiniran, Seun Afolabi, and members of N.F.C.S and J.C.I club, I am grateful to you all.

Finally, words are not enough to say thanks to Almighty God who gave me the best parents in the World, Engr. James. E. Erhueh and my beloved mother Mrs. F. Erhueh who took care of me from childhood. Their support and encouragement sees me through my years of study. Without them this project report would not have seen the day's light.

TABLE OF CONTENT

TITLE PAGE	i
DECLARATION.....	ii
CERTIFICATION.....	iii
DEDICATION.....	iv
ACKNOWLEDGEMENT.....	v-vi
TABLE OF CONTENT.....	vii-viii
ABSTRACT.....	ix
CHAPTER ONE: GENERAL INTRODUCTION.....	1
1.1 INTRODUCTION.....	1
1.2 LITERATURE REVIEW.....	4
1.3 AIM AND FEATURES.....	6
1.4 PROJECT LAYOUT.....	7
CHAPTER TWO: GENERAL DESIGN DESCRIPTION.....	9
2.1 DESIGN METHOD.....	9
2.2 THERMAL TRANSDUCER UNIT.....	10
2.3 THE CONDITIONING CIRCUIT UNIT.....	13
2.4 SWITCHING UNIT.....	16
CHAPTER THREE: SYSTEM DESIGN AND ANALYSIS.....	18
3.1 INTRODUCTION.....	18
3.1.1 CIRCUIT DIAGRAM.....	22
3.2 THERMISTOR.....	23

3.3 COMPARATOR.....	23
3.4 TRANSISTOR SWITCH.....	27
3.5 LED INDICATORS.....	30
3.6 RELAY SWITCH.....	32
3.7 POWER SUPPLY UNIT.....	34
CHAPTER FOUR: CONSTRUCTION AND TESTING.....	40
4.1 CONSTRUCTION.....	40
4.2 TESTING.....	41
4.3 RESULTS.....	42
CHAPTER FIVE: CONCLUSION AND RECOMMENDATION.....	43
5.1 CONCLUSION.....	43
5.2 RECOMMENDATION.....	44
REFERENCES.....	45

ABSTRACT

The design and construction of thermostatic control for heating system is described in this project. The report confines itself to the demonstration of the detection of a particular temperature, above it, hence dangerous to the system and tends to switch off the heating element.

The design is based on the principle of using temperature sensor (transducer) that converts temperature variation within the system, example: microwave oven, tea-kettle, furnace, and rooms e.t.c. to electrical signal; thus, used to control the heating element automatically. The design description and analysis, the circuit/block diagrams, theory and values are provided to give readers adequate understanding and information about the system.

Though one thermistor (temperature transducer) is used in this system, other sophisticated ones can be employed by using the proper type of switch. Also, a digital readout can be incorporated to display the temperature readings. The system is designed to be used with minimum possible human attention, since, the control is automated because once it is set, it stays set, unless altered or adjusted.

CHAPTER ONE

GENERAL INTRODUCTION

1.1 INTRODUCTION

In the recent times, most heating systems are determined and governed either directly or indirectly by the principle of thermostatic control; which is incorporated to maintain a desired temperature set by a thermostat that regulates the input of heat. In the days of old, the control of water temperature is done via the adjustment being made according to outside weather or room temperature. As this method is liable to error, hence there arise the need for a good control for heating systems by thermostatic that will do the adjustment automatically. A temperature monitoring device that will switch OFF automatically as the critical temperature is exceeded and switch ON when it is below the lower temperature. Since, temperature is the degree of hotness or coldness of a body or system.

Thermostatic control has the aim of managing heat as much as possible while annulling overheating and underheating. Solar/external heat gain and internal heat gain may often contribute significantly to the total daily heat requirement of any heating environment; and this superimposed on the normal designed output of a heating system, which can lead to uncomfortably high internal temperature. Thus, a quickly

responsive control is therefore desirable. To achieve this aim, the switch OFF and ON type of thermostatic control is greatly considered in this project.

The switch OFF and On type of thermostatic control is an electronic device that triggers automatically when the temperature inside an incubator, a room, kiln, furnace, microwave oven, or any heating environment that exceeds the critical temperature, t_c . Generally, the critical temperature, t_c varies from one heating system to another. This device controls one or more heating source to maintain a desired temperature. Hence, this temperature, t_c is provided for any specific design of experimental observation. Temperature fluctuation is a physical event and our ability to measure the rate of temperature variations in any heating system determines our knowledge of that quantity.

To execute this function of thermostatic control for a heating system we must have a sensor (thermistor), conditioning circuit (comparator), triggering unit (relay), and heating element. The block diagram in fig. 1.1 summarizes the main spring for the operational outline of the control as regards the heating system.

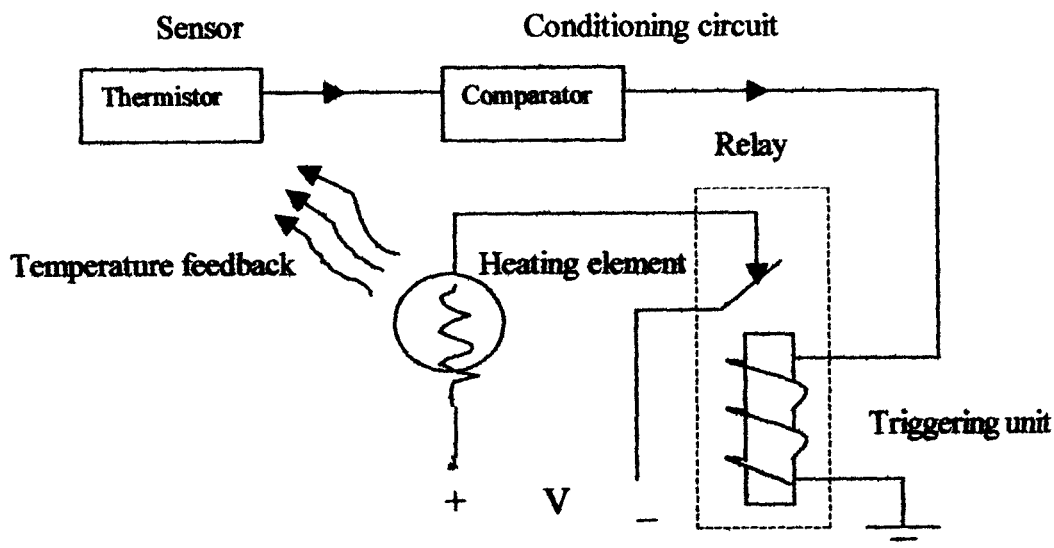

Fig.1.1 Block diagram of thermostatic control for heating system

For this project, the sensor is a thermistor, which is used as a temperature transducer that detects the changes in temperature and produces a desired result. The conditioning circuit, which is the comparator, compares the input signal with the reference voltage; and when input signal exceeds or lower than the reference signal, the output of the comparator changes its value.

Temperature control system or thermostatic control for heating system is a feedback control system that reacts to a change in temperature, since a heating element carries fairly large electric currents (amperes rather than milliamperes); the change in temperature affects the sensor (temperature transducer), and in turn gives back an electrical signal to control the heating element in the system.

1.2 LITERATURE REVIEW:

In inception, thermostatic control itself did not take off till 80s when the need become very important to control heating systems automatically. The desire for warmth and comfort may have motivated man's first use of a fire. The earliest evidence shows that man used wood and charcoal in open fires to produce warmth, as well as to prepare food, in his cave or shelter. American Indians, who built fires in their hurts and tepees, which had openings to allow the smoke to escape, used these simple open fires as late as the 19th century. While in 300 B.C the Europeans built crude fireplaces with connecting chimneys; with this arrangement, combustion efficiency and ventilation were much improved.

By the first century B.C., the Romans had developed the hypocaust, which provided a better way to heat a room. The hypocaust was a basement with a low arched-vault furnace made of brick or stone. The hot air from the furnace passed through tile flues in the walls of the room above the furnace, heating the room. The first bimetal temperature-responsive device was a "grid-iron" pendulum built in England in 1726 to improve the accuracy of a clock operating under varying temperature conditions.

In 1743, Benjamin Franklin invented the iron Franklin stove and he gained a reputation of high efficiency in the American colonies. The use

of stoves provided a new way to heat rooms. The fire was contained in a combustion chamber usually made of ceramic or iron sections. It heated the stove walls, which in turn heated the room, mainly by convection of the room air over the hot surface. However, steam boiler was developed for the steam engine in England, but engineers soon learn to adapt it for central steam heating systems. Steam heating systems are particularly suitable for serving large public building because large quantities of heat can be carried in long distances by small pipes.

As technology advances, the word “thermostat” was introduced in 1830 by Andrew Ure, a Scottish professor of chemistry, who was issued a patent on what he called “a heat-responsive element consisting of a bar of steel united to zinc by numerous rivets”. This bimetallic bar bends with temperature change because of the different expansion rates of the metal strips, and the bending can be used to actuate valves or dampers to control heating systems.

Bimetal- strip thermostats of improved designs have been developed. One other type has a low expansion rod contained in high expansion tube. For example, a steel rod and nickel tube sealed together at one end. Construction of the tubes at one end of the rod, actuating a valve or electric switch. Thermostats used in homes or small buildings usually are low- voltage electric controls that turn a burner ON or OFF as required.

In other word, other thermostats exist that basically uses almost the same type of principle but different types of input and output units, though there are some heating controlling device whose principle is quite different from that used in this project. Some systems are based on the principle of analog to digital converter. Where the analog voltage produced by the thermal transducer is converted into its digital equivalent, which is fed into the 7-segment display unit from where the temperature variation may be readout.

Finally, in getting information on the working principles and design of the thermostatic control for heating system itself, which is the main aim of this project, it is most expedient to have a clear and concise knowledge of the working conditions of the various component as used in the design of the system.

1.3 AIM AND FEATURES

All type of modern heating system - kiln, microwave oven, electric furnace(s), room heater, and incubator, are capable of supplying highly satisfactory heating performance when properly designed and installed. Conversely, any system can be disappointing when it is improperly designed or installed. Hence, the major objective of this project is to design and construct a thermostatic control for heating systems that will be automatic by turning OFF and ON.

However, to achieve this objective, the features considered to incorporate the entire system design and construction are:

- i. It is of low installation cost.
- ii. It needs less human attention.
- iii. It is automatic in operation.
- iv. It is generally used to control different heating systems.

1.4 PROJECT LAYOUT

This project report comprises of five chapters for easy grasp of knowledge governing the design and construction of thermostatic control for heating systems. Chapter one is based on the general introduction, which encompasses the literature, review-the brief history of the system. Also, the aim and features of this project were highlighted.

In chapter two, it focused on the general design description that contains design method and other sub-division units that constitute the design of this work for easy explanation of each component functions. Chapter three is the system design and analysis that comprises of general circuit mode of operation; and general heating system principles and design were discussed.

Also, chapter four major's on construction and testing, this contains the results and the project casing.

Finally, the last chapter (i.e. five), which based on the conclusion and constrains encounter during the course of this project. The recommendation for further improvement on this work is hinted upon.

CHAPTER TWO

GENERAL DESIGN DESCRIPTION

2.1 DESIGN METHOD

This project is based on feedback-closed loop system so as to aid detection of heat in an environment it is designed for. The components used in this project are based on their cost, availability and effectiveness. Hence, the design procedure is limited to a prototype system so as to demonstrate temperature control in heating systems.

The main units in the temperature controlling system are: the temperature transducer unit with their individual sensors (a negative or positive coefficient thermistor whose resistance varies with temperature). This implies that for a constant current (I), the voltage (V) variation across the thermistor is directly proportional to the resistance (R) and hence temperature (t) variation.

Mathematically,

$$V \propto R$$

$$V=IR \text{ [I=constant of proportionality]} \dots\dots\dots(1)$$

The thermistor is placed in a Wheatstone bridge circuit and its voltage drop variation due to temperature is fed into a comparator.

A 741 operational amplifier (Op.Amp.) is connected as a comparator. This device is capable of high resistance, high gain and low

output. One input terminal is placed at a fixed voltage with the help of a potentiometer while the other is placed at a varying voltage, which depends on the voltage from the thermistor. The output from the comparator is then passed onto a transistor switch. The NPN transistor is used to switch ON or OFF the heating element via the relay that does the switching and indicated by the light emitting diode.

2.2 THERMAL TRANSDUCER UNIT

2.2.1 INTRODUCTION

Transducer is a device, which converts nonelectrical input variables to electrical, usually analog form, such as solar energy into electrical energy, chemical energy into electrical energy etc. Typical input transducers are thermistors, photocells, thermocouples and typical output transducers are solenoid, loudspeakers, electric motors etc. Operating temperature range, response time, stability and environment are the leading factors when choosing a temperature sensor.

2.2.2 TEMPERATURE SENSOR

Temperature is the most frequently measured process variable, and any material with a temperature sensitive characteristic can be used for as a “thermometer”. Electrical temperature sensing devices can be used for remote temperature signaling. Hence, temperature sensor or transducer is a device that senses the temperature variation in an environment to give

useful electrical signal. Different sensors are made from different materials, but generally, their properties changes with rise or fall in temperature and its is by observing those very changes in the electrical properties of these devices that it has been possible to create a wide variety of useful temperature sensors, and the one used for this project is the thermistor. The need for it is based on availability, reliability and it is low in cost.

2.2.3 THERMISTOR

A thermistor is a “thermally sensitive resistor”. This is a semiconductor composed of metallic oxide such as manganese (Mn), nickel (Ni), cobalt (Co), copper (Cu), iron (Fe), and titanium (Ti). Basic ceramics technology is utilized to fabricate thermistors in wafer, disk, bead, and other shapes. There are two basic types of thermistors- negative temperature coefficient (NTC) and positive temperature coefficient (PTC). NTC thermistors are much more commonly used than PTC thermistors hence it is used for this project. The resistance of NTC thermistors decreases with increasing temperature.

Thermistors application is based on the resistance-temperature characteristic of a thermistor. NTC thermistors give a relatively large output (change of resistance) for a small temperature change. This output can be transmitted over a large distance. No compensation for ambient

temperature is needed. The amount of change per °C is expressed by Beta value (material constant) or Alpha coefficient (resistance temperature coefficient). The larger Alpha or Beta the greater change in resistance with temperature.

The resistance versus temperature relationship is not linear. With increasing temperature the nonlinearity decreases. The Steinhart-Hart Equation expresses the relationship between resistance and temperature:

$$1/T = a + b \ln R + c (\ln R)^3 \dots\dots\dots(2)$$

Where; T is temperature, R is resistance and a, b, c are coefficients derived from measurements. The resistance-based transducer (the thermistor) is shown in fig. 2.2.3 below.

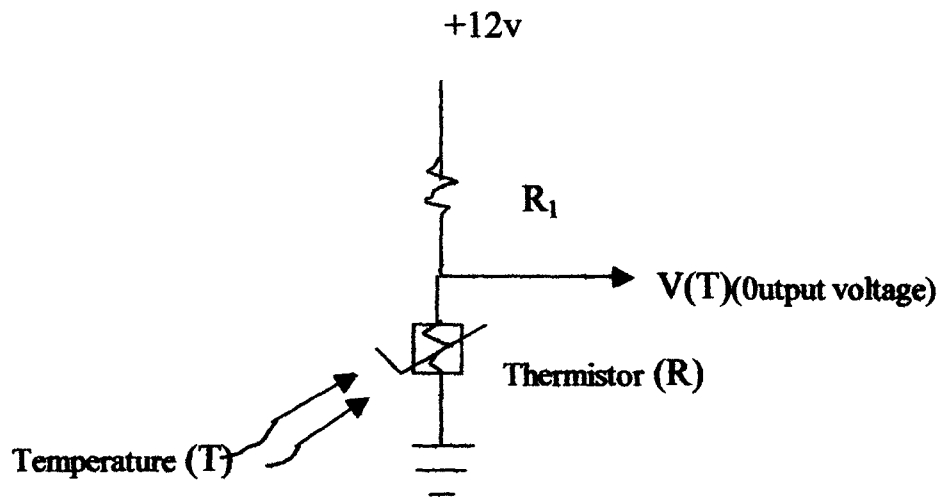

Fig. 2.2.3 A resistance-based transducer (Thermistor)

The output voltage V (T) of the thermistor circuit shown fig.2.2.3 is approximately proportional to the temperature T of the thermistor. A

change of one degree Celsius (1°C) in T can cause R , and hence $V(T)$, to vary by as much as 10 percent.

2.3 THE CONDITIONING CIRCUIT UNIT

The conditioning circuit unit consists of the voltage comparator, which compares input signal V_{in} with a reference voltage V_{ref} . When the input signal V_{in} exceeds the reference signal V_{ref} the output of the comparator, V_{out} changes from its value when V_{in} is less than or equal to V_{ref} . A comparator circuit exhibits a nonlinear operational amplifier characteristics, where as a differential amplifier behaves linearly.

A comparator is therefore a two input; one output voltage comparing twice that is capable of high gain, high input resistance and low output resistance. While this may be taken as the definition of an operational amplifier, it should be noted that voltage comparison is just one of the areas of application of operational amplifiers. A comparator thus performs the following functions:

- i. Detects two input voltages.
- ii. Provides an output that has two discrete values.

The differential voltage comparator is operated with a dual power supply with a common ground, thus enabling the output to swing either positive or negative with respect to ground. But the 741 op-amp may also be operated using positive to ground supply. One input terminal is

denoted negative, it gives an inverted output (that is the inverting terminal) and the other is denoted positive, it gives a non-inverting output (that is the non-inverting terminal). The output of the device is ideally zero when identical signals are simultaneously applied to both inputs since the two signals are cancelled out by the differential action of the amplifier. The output of the circuit is proportional to the differential signal between the inputs. Thus,

$$V_o = A_o(V_{in} - V_{ref}) \dots \dots \dots (3)$$

Where;

A_o = the open loop gain of the op-amp.

V_{in} = the input signal at the non-inverting terminal.

V_{ref} = the reference voltage at the inverting terminal

V_o = the output voltage.

The op-amp symbol with the basic pin connections is shown in fig.2.3

2.3.1 THE OP –AMP AS A COMPARATOR

The 741IC op-amp is used in this project as differential voltage comparator circuit operating on whether, one of the inputs is greater or less than the other. So the two input voltage levels therefore determine the output voltage. This is mostly determined by the saturation position of

the op-amp; fig.2.3.1 shows the transfer characteristics of the differential voltage comparator circuit.

When the sampled input voltage V_{in} is greater than that of reference voltage V_{ref} by more than a few hundred micro volts, the output is driven into saturation positively, and when the sampled voltage is a few hundred of micro volt less than the reference voltage the output is driven to negative saturation. It is the magnitude of the differential input voltage that detects the magnitude of output voltage, so the absolute values of input voltage are of little importance. The circuit thus functions as a precision voltage comparator or balance detector.

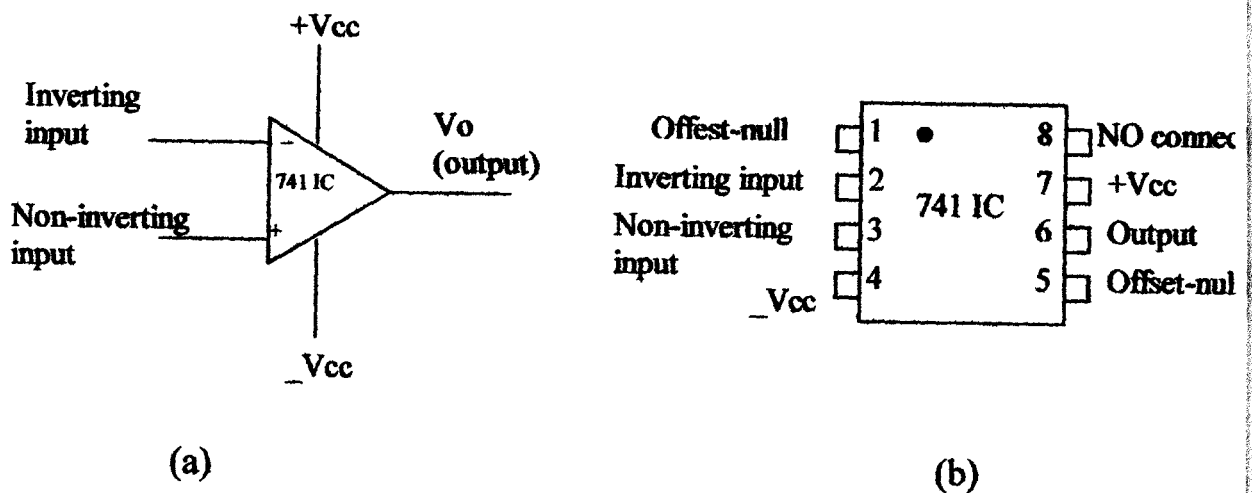

Fig. 2.3 Operational amplifier; (a) Circuit symbol

(b) Basic pin configuration

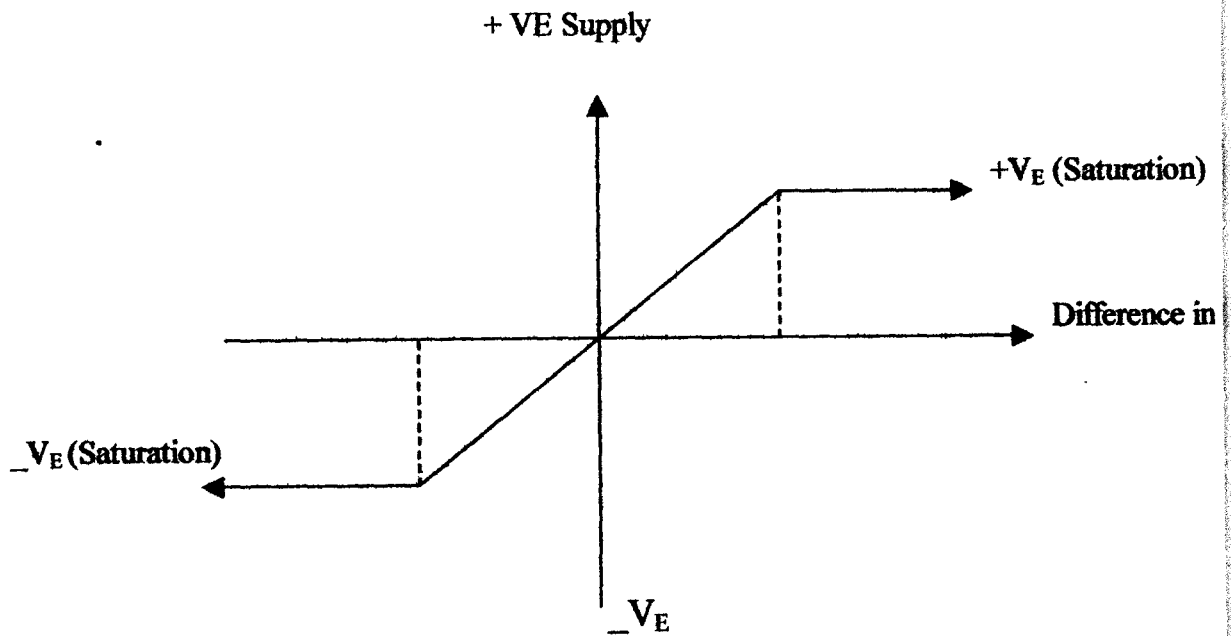

Fig 2.3.1 Transfer characteristic of the differential voltage comparator circuit.

2.4 SWITCHING UNIT

The switching unit is setup or made up of the relay and the transistor. This operation is achieved via the transistor that amplifies current to the relay, which eventually triggers OFF and ON the heating element.

The difference voltage is fed to the input terminals of the 741 IC op-amp, which is connected as a voltage comparator or differential voltage switch, and the output of op-amp is fed to the 12 volts relay via the transistor (NPN) BC184L. That is, when output of the comparator is fed to the base of the transistor (BC184L), it goes to its saturation point thereby allowing current to flow through the 12 volts relay coil, that is connected to the collector terminal. The collector current I_c , energized the relay through the coil thereby closing the relay switch on the heating element.

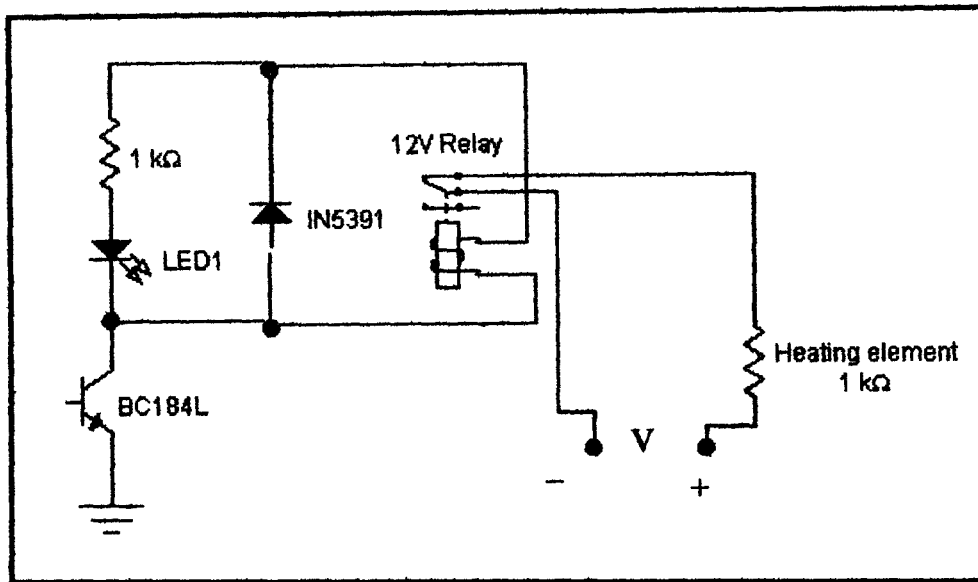

Fig. 2.4 Block diagram of switching unit.

Considering the transistor in the circuit of fig.2.4, when base current $I_B = 0$, collector current I_c is a small leakage current and voltage drop across the load would be negligible.

CHAPTER THREE

SYSTEM DESIGN AND ANALYSIS

3.1 INTRODUCTION

This inexpensive project can form the basis of a number of sophisticated control for heating systems. The circuit uses a couple of ordinary thermistor as temperature - sensing elements, and uses a relay as an output 'switch'. The circuit action is such that the relay turns ON the heating element only when temperature 'A' (sensed by the thermistor) is in the low value and switch OFF when temperature 'A' (sensed by the thermistor) exceed its critical value, and this action occurs irrespective of the absolute value of either temperature.

When the thermistor reduces in resistance due to increase in temperature, hence the input voltage drop across the R_3 ($5.6\text{k}\Omega$) resistor is low. Thus the output voltage from the 741IC (op-amp) is less than 0.6V that could not bias the transistor (BC184L) to energize the relay for the heater to trip ON. The action is such that the relay turns ON when the temperature rises a little above the low value. The unit is powered from a 12volts supply. In use, the R_{v_1} is simply adjusted so that the relay is just ON and the heater is ON when both the R_3 resistor and thermistor R_{Th} are at the same temperature. The relay then turns OFF when the temperature of the thermistor is raised above the critical temperature. The relay is

12volts type with a coil resistance greater than 120Ω . The analysis of each component as used in this project is stated subsequently.

3.1.1 GENERAL CIRCUIT MODE OF OPERATION

The general circuit is setup as shown in fig 3.1.1 when the mains supply is switch ON by the key, then the 12volts power supply is applied to the control circuit, the heating element is switched ON, since the relay is a normally opened type. The slider Rv_1 , acting as the temperature control is used to preset the reference voltage V_{ref} so that the comparator output voltage V_o , cannot bias the transistor T_{R1} . Thus, at this point V_{ref} is greater than V_{in} .

However, the V_{ref} is fed to the inverting input of the comparator, while the non-inverting input is fed from a potential divider, which consists of R_2 and R_{Th} to the comparator. As temperature increases due to heating, the resistance of the thermistor is also decreasing causing a rise in the input voltage V_{in} until the resistance of the thermistor is just the same as R_4 , at this point V_{in} has risen to a value of 6.462V with a corresponding temperature of 60 degree Celsius [$^{\circ}C$] measured with a thermometer, which is the critical temperature for this project.

Therefore, V_{ref} is less than V_{in} . The rise in V_{in} causes the comparator to rise high and the output voltage V_o is just adequate to bias the transistor T_{R1} . The yellow LED, D2 turns ON to indicate that the collector

current I_c is flowing into the relay coil to energize it. Since the relay switch is normally opened type becomes close thereby switching on the heating element and the Led, D2 is ON indicating ON mode of the heating element.

Also, as temperature increases above the critical temperature, the resistance of the thermistor R_{Th} decreases below that of R_4 this causes a fall in V_o . At this time V_{ref} is greater than V_{in} , and the output voltage of the comparator V_o becomes low; which is not adequate to bias the transistor thereby cutting OFF the transistor T_{R1} and NO current flows through the transistor to the relay.

Finally, as the temperature decreases; the resistance R_{Th} of the thermistor will begin to rise until it's resistance is equal to R_4 , also the relay coil becomes de-energized and the heating element is triggered OFF again since the relay switch has return to it's original position.

3.2.1 GENERAL HEATING SYSTEM PRINCIPLES AND DESIGN

Certain design principles are common to all types of heating systems, such as incubator, kiln, microwave oven, rooms and buildings. First, the heat loss of the heating system and its room must be determined for a design-calculated data to suit it. Secondly, the type of heating system must be selected to match the calculated heat loss.

Finally, the correct location of air registers, convectors (apparatus for heating by convection), heating panels, and other equipment must be determined to ensure even temperature distribution and air movement throughout the system. The automatic control system is worked out, and auxiliary components are determined.

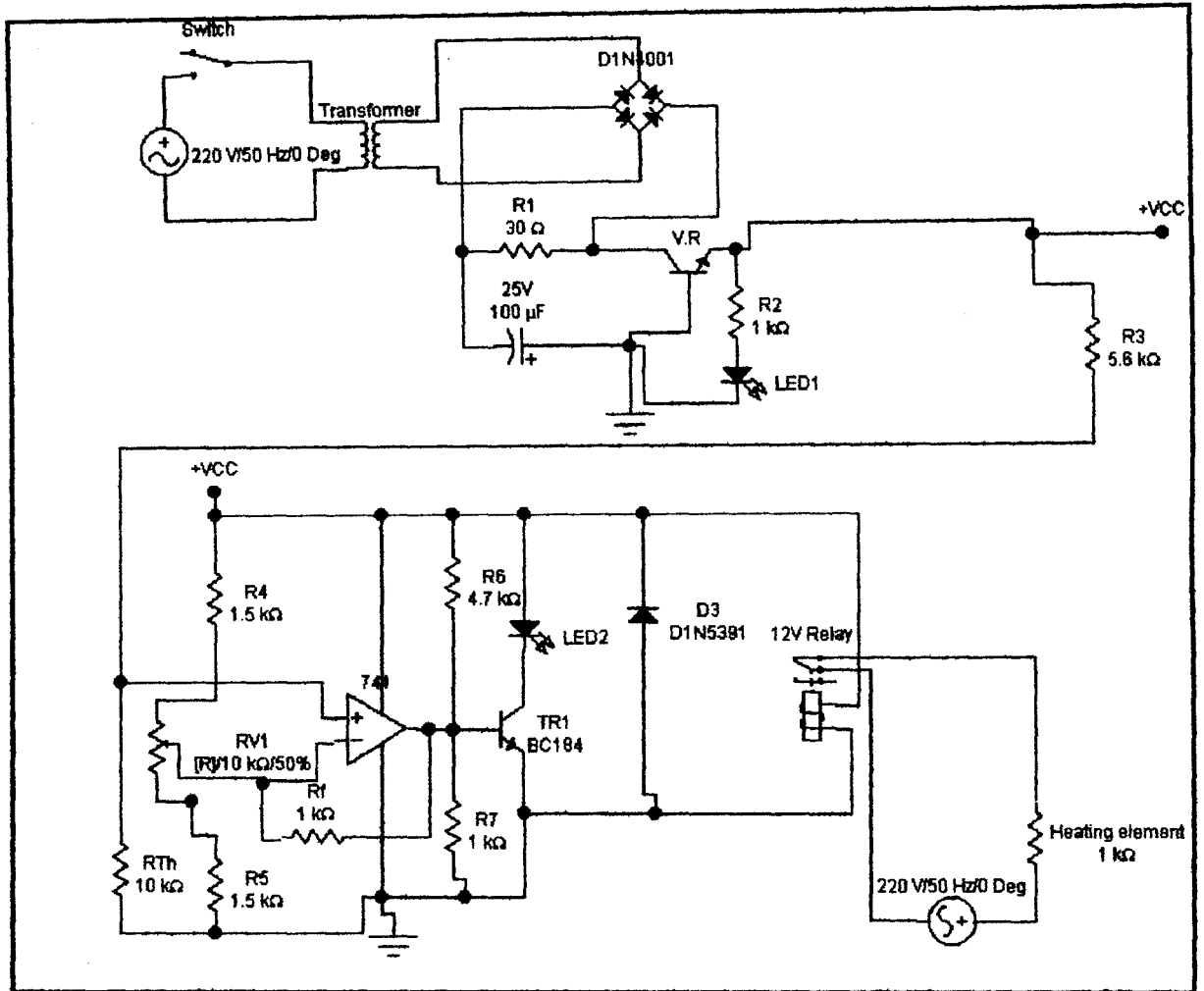

Fig.3.1.1 Circuit for Thermostatic Control For Heating systems

3.2 THERMISTOR

A heavily doped semiconductor can exhibit a positive temperature coefficient of resistance PTC, for under these circumstances the material acquires metallic properties and the resistance increases because of the decrease in carrier mobility with temperature. Hence, for this project the negative temperature coefficient of resistance NTC is used and is of $10\text{k}\Omega$, this transducer reduces in resistance as temperature increase. The typical useful temperature range of NTC is -80°C to $+500^{\circ}\text{C}$.

3.3 COMPARATOR

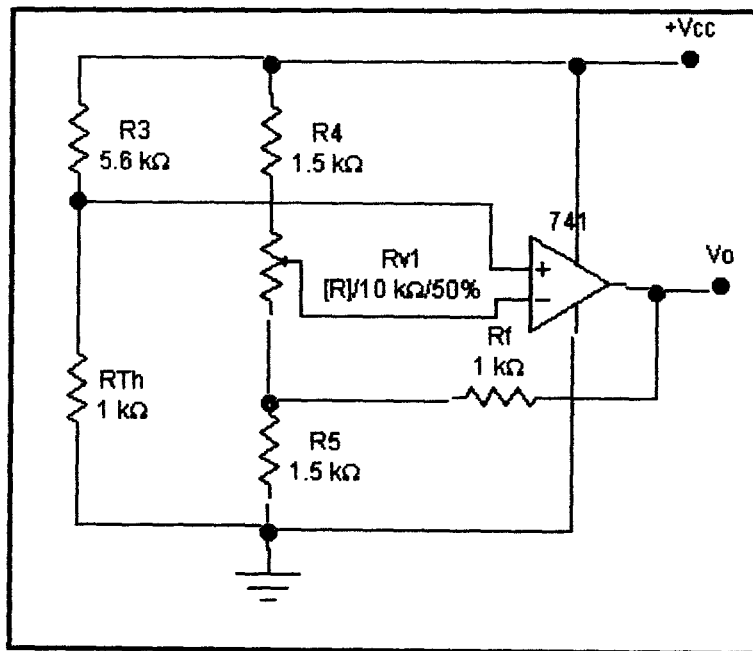

Fig. 3.3 The Comparator Circuit.

A voltage comparator senses the relative polarity of the difference between the voltages applied to the comparator's two inputs. Most comparators are essentially high-gain differential amplifier operating in

the open-loop manner and driving an output stage conditioned for specific logical voltage levels. Fig.3.3 shows an operational amplifier (741IC) representing basic circuit of a comparator and its transfer characteristics.

However, it is required to design a comparator circuit that will compare two signals (one from the thermistor and the other from the variable resistor R_{V1}) to give an output when the thermistor temperature is at the critical temperature and to give zero output when it is above the critical temperature. The critical temperature for this project is 60°C to achieve its aim.

The inverting input of the 741IC is held at a fixed reference voltage V_{ref} , and the non-inverting terminal is connected to the thermistor. The thermistor resistance R_{Th} is $4.8\text{k}\Omega$ corresponding to the critical temperature. From equation (3), the output of the comparator is;

$$V_o = A_o [V_{in} - V_{ref}]$$

$$\text{Also, } V_o = A_o * V_{od} \dots\dots\dots(4)$$

Where, A_o is an open loop gain of the op-amp. And,

$$V_{in} = [R_3 / (R_3 + R_{Th})] * V_{cc} \dots\dots\dots (5)$$

$$V_{ref} = [R_4 + R_{V01} / ((R_4 + R_{V01}) + (R_5 + R_{V02}))] * V_{cc} \dots\dots\dots(6)$$

Hence, from equation (5);

$$V_{in} = [R_3 / (R_3 + R_{Th})] * V_{cc}$$

Where, $R_3 = 5.6\text{k}\Omega$, $R_{Th} = 4.8\text{k}\Omega$, $V_{cc} = 12\text{V}$

Therefore;

$$\begin{aligned}V_{in} &= [5.6\text{k}\Omega/(5.6\text{k}\Omega + 4.8\text{k}\Omega)]*12\text{V} \\ &= 6.462\text{V}\end{aligned}$$

The current through V_{in} ;

$$\begin{aligned}I_{vin} &= 6.462\text{V}/10.4\text{k} \\ &= 0.621\text{mA}\end{aligned}$$

From equation (6);

$$V_{ref} = [(R_4+R_{V01})/((R_4+ R_{V01})+(R_5+R_{V02}))]*V_{cc}$$

Where; $R_4 = R_5 = 1.5\text{k}\Omega$, $V_{cc} = 12\text{V}$, $R_{V01} = 5.3\text{k}\Omega$, $R_{V02} = 4.7\text{k}\Omega$.

Therefore;

$$\begin{aligned}V_{ref} &= [(1.5\text{k}\Omega+5.3\text{k}\Omega)/((1.5\text{k}\Omega+5.3\text{k}\Omega)+(1.5\text{k}+4.7\text{k}))]*12\text{V} \\ &= [6.8\text{k}\Omega/(6.8\text{k}\Omega+6.2\text{k}\Omega)]*12\text{V} \\ &= 6.277\text{v}\end{aligned}$$

The current I_{ref} through V_{ref} ;

$$\begin{aligned}I_{ref} &= 6.277\text{V}/ 13\text{k}\Omega \\ &= 0.483\text{mA}\end{aligned}$$

The non-inverting input V_{in} , of the comparator is higher than the inverting input V_{ref} . This indicates the ON mode of the heating element. Hence, if the thermistor is heated above the critical temperature it falls in resistance, causing output voltage to go low again and the OFF mode is indicated on the heating element.

Thus, from equation (4),

$$\begin{aligned}V_o &= A_o [V_{in} - V_{ref}] \\ &= A_o [6.462 - 6.277] \\ &= A_o [0.185]\end{aligned}$$

$$\text{Where; } A_o = 1 + (R_6/R_f) \dots \dots \dots (7)$$

$$\text{And, } R_6 = 4.7k, R_f = 1k$$

$$\begin{aligned}\text{Therefore; } A_o &= 1 + (4.7k/1k) \\ &= 5.7\end{aligned}$$

$$\begin{aligned}\text{Hence, } V_o &= [5.7 * 0.185] \\ &= 1.055V\end{aligned}$$

The “volt-equivalent of temperature” across the thermistor at the critical temperature of 60°C is defined by

$$V_T = KT/q \dots \dots \dots (8)$$

Where; K = Boltzmann constant in joules per degree Kelvin.

$$= 1.38 * 10^{-23} \text{ J/}^\circ\text{k.}$$

T = Temperature in Kelvin

$$= [60 + 273] \text{ k}$$

$$= 333k$$

q = magnitude of charge

$$= 1.602 * 10^{-19} \text{ C}$$

$$\text{Therefore, } V_T = (1.38 * 10^{-23}) * 333 / (1.602 * 10^{-19}) = 28.69 \text{ mV}$$

3.4 TRANSISTOR SWITCH

Modern transistors are invariably silicon types and are available in either NPN or PNP forms. Transistors are three-terminal devices that comprises of emitter, collector and the base. It should thus, be readily apparent that one terminal of a transistor must be 'common' to both the input and output of any practical amplifier circuit. Transistors tend to have diverse applications such as;

Linear: - Transistors designed for linear applications (such as low-level voltage amplification).

Switching: - Transistors designed for switching applications.

Power: - Transistors which operates at significant power levels.

Radio frequency: - Transistors designed for high-frequency applications.

High-voltage: - Transistors designed specifically to handle high voltages.

For the purpose of this project, the NPN type of transistor BC184L is used for current amplification, and provides the switching effect for the 12V relay.

Typical characteristics of BC184L transistor are shown in table 1

Type	BC184L
Material	Silicon
Construction	n-p-n
Case style	T092
Maximum collector power dissipation (P_C)	300mW
Maximum collector current (I_C)	200mA
Maximum collector- emitter voltage (V_{CEO})	30V
Maximum collector-base voltage (V_{CBO})	45V
Current gain (h_{fe})	250 (minimum)
Transition frequency	150MHz

Table 1

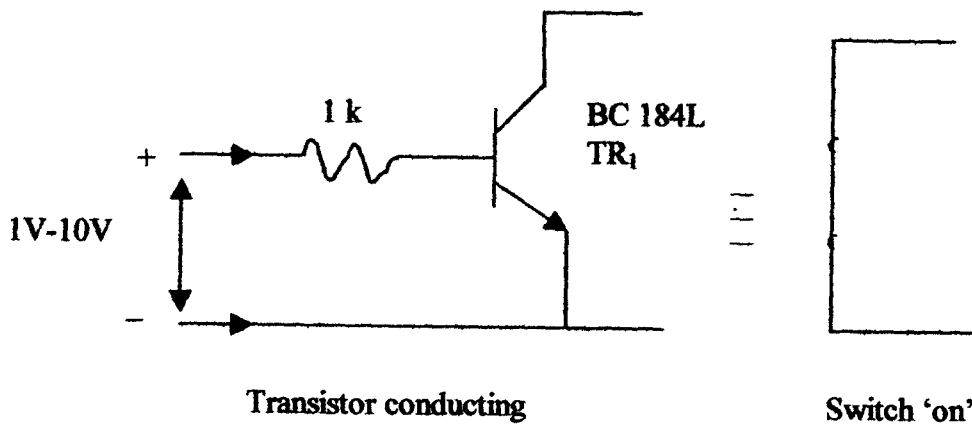

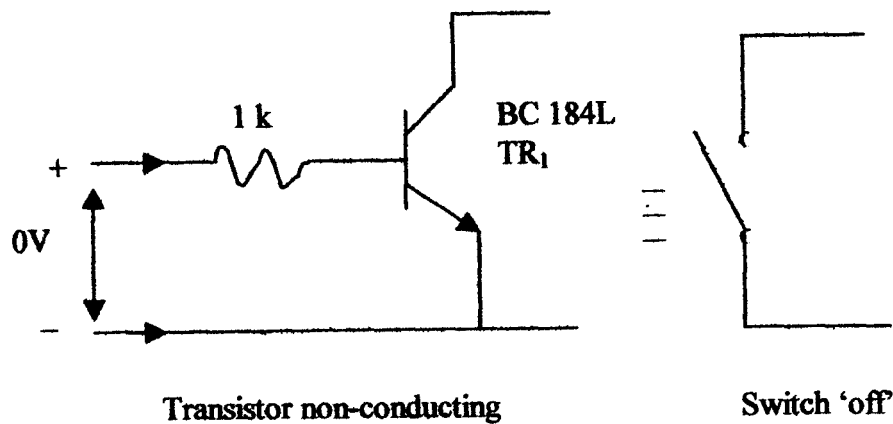

Fig.3.4 The transistor switch

A conducting transistor is equivalent to a switch in the 'ON' state while a non-conducting transistor is equivalent to a switch in the 'OFF' state, as shown in fig.3.4. The transistor is operated under saturated switching conditions; in the conducting state sufficient base current I_B must be applied for the collector voltage to fall to approximately 0V. Provided the transistor operates under saturated conditions, dissipation within the transistor is kept to a relatively low level. The output of the op-amp is fed into the base of the transistor. When this transistor is saturated a current flows through the collector to the coil of the relay- when it is energized it switches close and the heating element is triggered.

The base voltage $V_B = [R_7/(R_6+R_7)] * V_O \dots \dots \dots (9)$

$$= [1k\Omega/(1k\Omega+4.7k\Omega)]*1.055$$

$$= 0.185V$$

The base current $I_B = V_B/R_7 = 0.185V/1000\Omega \dots \dots \dots (10)$

$$= 0.185mA$$

The minimum value of base current I_B required for saturation is;

$$I_{B(min)} = I_{C(min)}/h_{fe(min)} \dots \dots \dots (11)$$

Where, $I_{C(min)} = 10mA$, $h_{fe(min)} = 250$

$$I_{B(min)} = 10mA/250$$

$$= 0.04mA$$

Since, $I_B = 0.185mA > I_{B(min)} = 0.04mA$, hence, the transistor is in saturation. This minimum base current is used to drive transistor to saturation to avoid breakdown.

The collector current I_C that is required to energize the relay is defined by

$$I_B = I_C/h_{fe}$$

Therefore, $I_C = I_B * h_{fe}$

$$= 0.185mA * 250$$

$$= 46.25mA$$

3.5 LED INDICATORS

The humble LED is a most versatile device and can be used in a variety of indicating applications. In this project, it is used as power

supply indicator as well as the heater indicator. Indeed, LEDs offer a number of significant advantages over filament lamps when used as indicators. They are small, robust, reliable, and inexpensive and require very low current.

In order to operate the LED a series resistor will be required to set the operating current of the device. The basic circuit of an LED indicator is shown in fig. 3.5. And the value of series current limiting resistor can be calculated from:

$$R_S = (V_{d.c} - V_f) / I_f \dots \dots \dots (12)$$

Where, $V_{d.c}$ is the input voltage

V_f = typical forward voltage

I_f = maximum forward current

Thus; $V_{d.c} = 12V$, $V_f = 2.1V$, $I_f = 12mA$

Therefore, $R_S = (V_{d.c} - V_f) / I_f$

$$= (12 - 2.1) / 12 * 10^{-3}$$

$$= 825\Omega$$

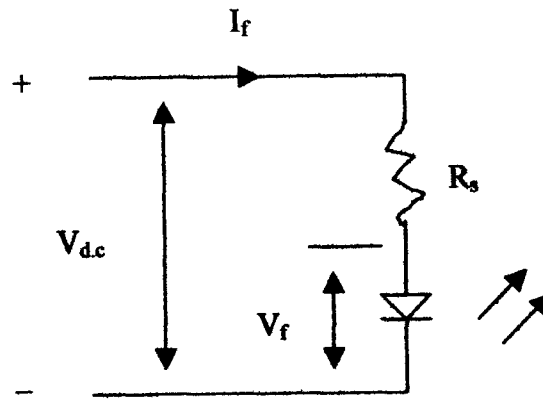

Fig.3.5 Circuit of LED indicator

3.6 RELAY SWITCH

The traditional method of switching current through a load, which requires isolation from the controlling circuit, involves the use of an electromechanical relay. This device offers a simple, low-cost solution to the problem maintaining adequate isolation between the controlling circuit and the potentially lethal voltages associated with an a.c mains supply.

However, when the coil is energized, a flux is set up in the relay core and the air gap. The relay function in this project is to operate as switch. Due to the energized nature, the armature is altered and the contact points open or close by responding to the change in physical quantities such as current, voltage, frequency, temperature etc. A relay in a normally closed position opens when activated while normally open relay closed when

energized. When energizing force is removed, the spring action returns the armature to its original state normally.

Thus, relay can be categorized as an under current and over voltage. An over voltage and over current relays operate when the actuating quantity exceeds its operating point or peak value. Also, an under voltage and under current relays operate when the actuating quantity falls below the reset value.

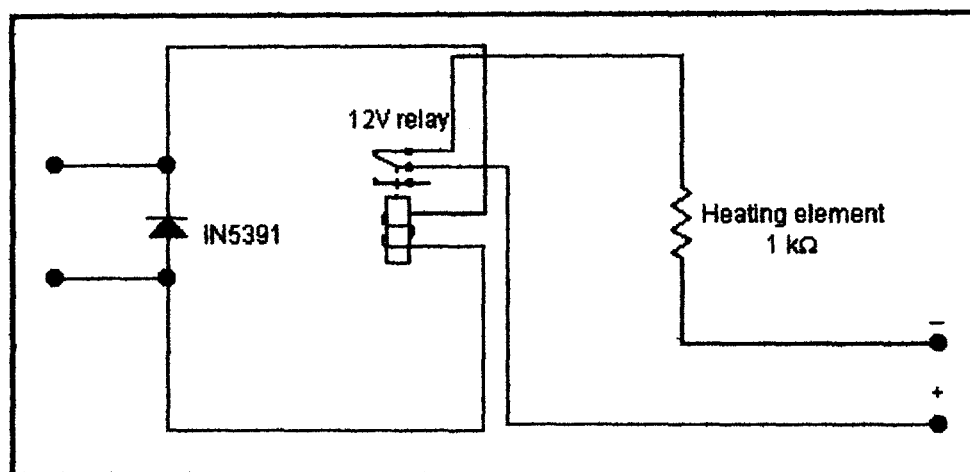

Fig. 3.6 Relay switch

The relay used in this project is the normally opened type. So that at a point in particular when it closes it switch ON the heating element. Since, the circuit is operating at 12V and the relay of selected resistance of 120Ω with maximum collector current of 200mA.

Thus, the relay current is defined by

$$I_{\text{relay}} = 12\text{V}/120\Omega = 100\text{mA}$$

Hence, this is the maximum current that can flow through the coil of the relay. The maximum collector current should be greater than the relay current. The diode IN5391 connected in parallel to the relay is a protection diode that prevents back electromotive force (e.m.f) from burning the transistor T_{R1} .

3.6 POWER SUPPLY UNIT

The most convenient and economical source of power is the domestic a.c supply; it is advantageous to convert this alternating voltage (usually, 220/240volts) to d.c voltage (usually smaller in value).

A typical d.c power supply consists of four stages as shown in fig.3.7

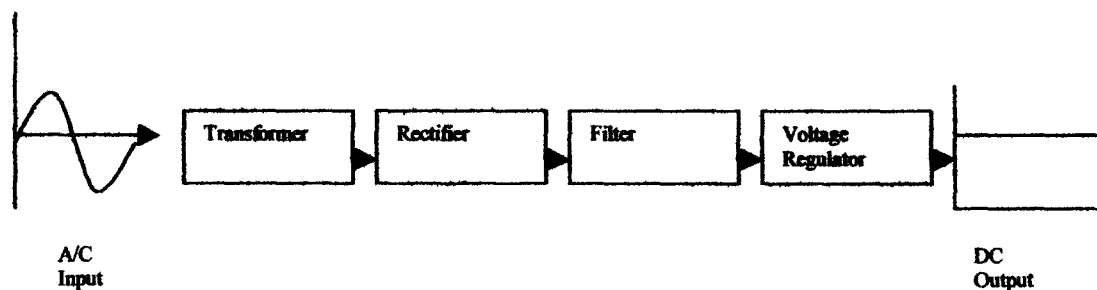
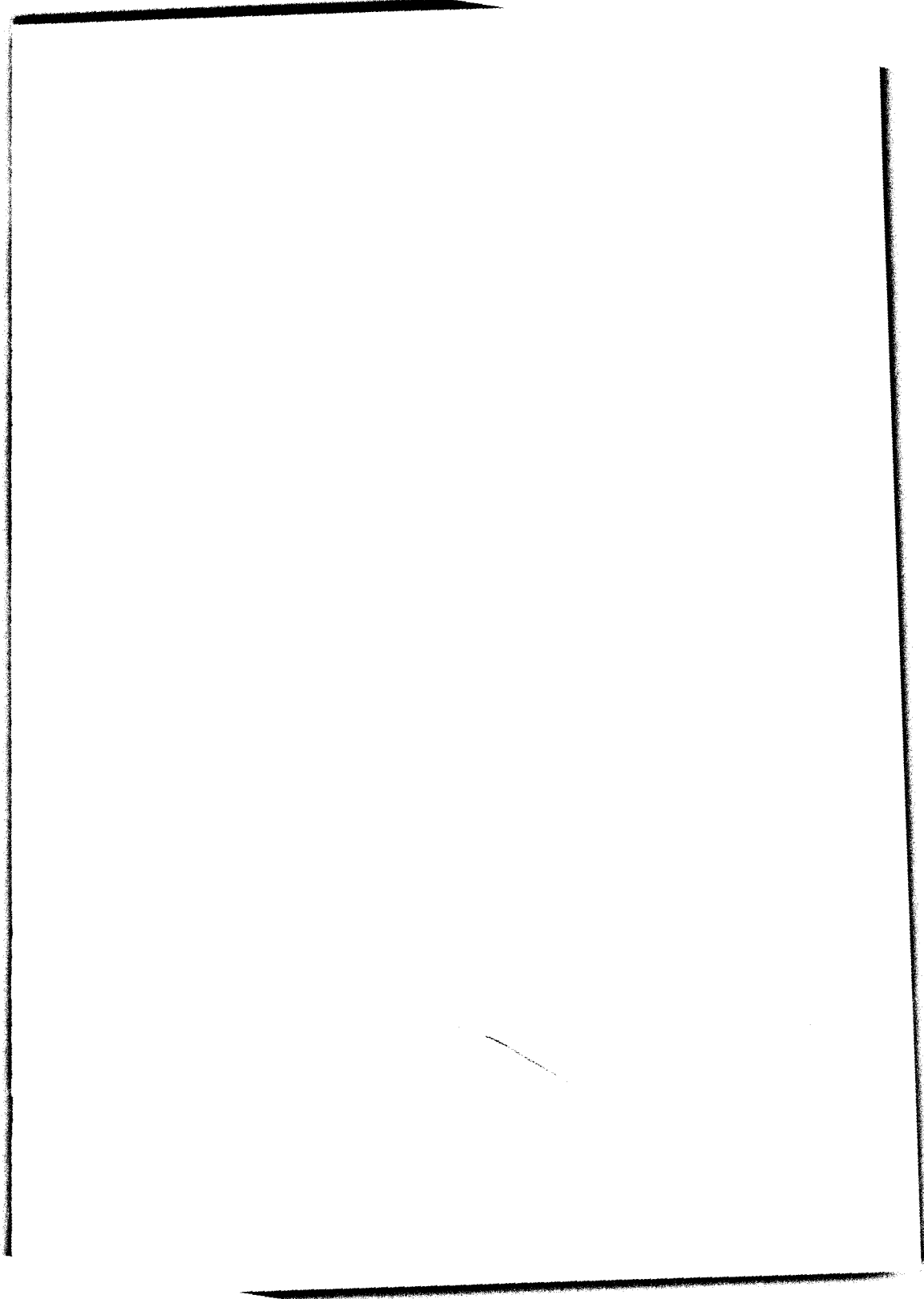
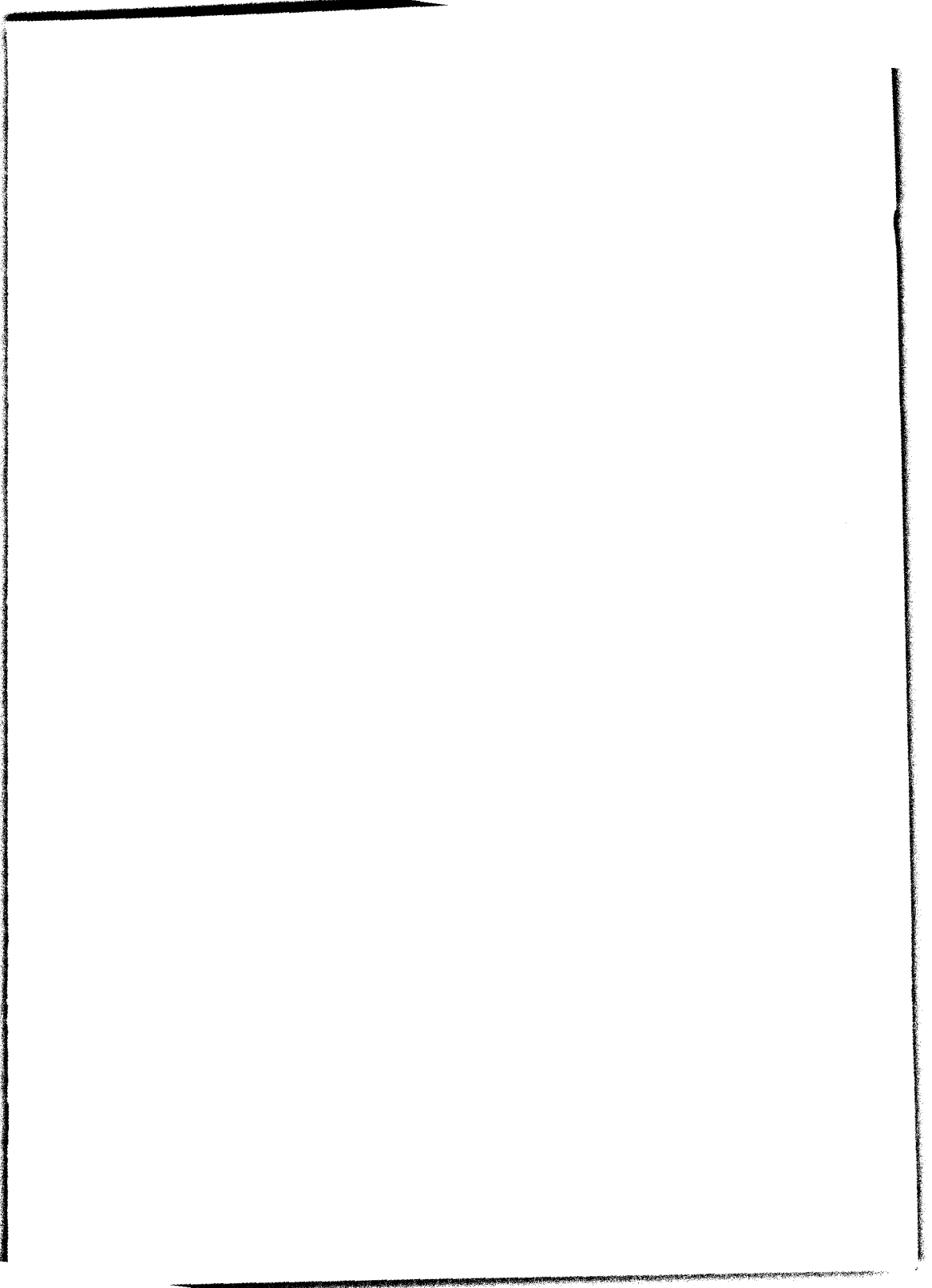

Fig. 3.7 Block diagram of dc power supply system.

3.7.1 TRANSFORMER

Its job is either to step up or step down the a.c supply voltage to suit the requirement of the solid-state electronic devices and circuits fed by





the d.c power supply. For this project the step-down type is used and is of 1A 12volts supply.

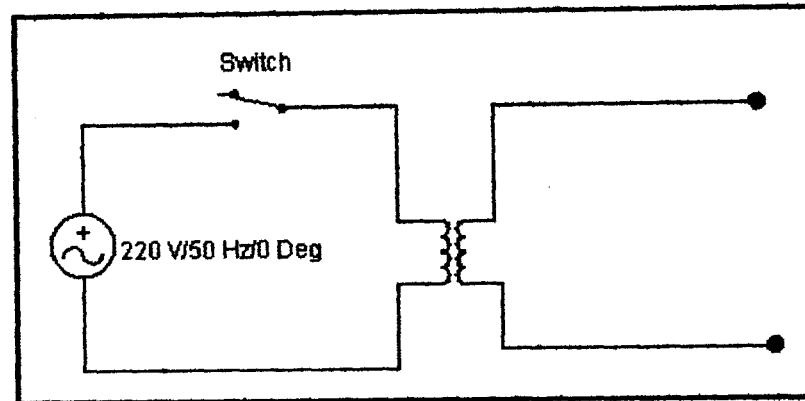

Fig. 3.7.1 Circuit diagram of a transformer.

3.7.2 RECTIFIER

Since a diode has the characteristic of having a much greater conductivity in one direction than in the other, it will produce a direct component of current when connected in series with an alternating voltage and a load. Hence, a rectifier is a circuit, which employs one or more diodes to convert a.c voltage into pulsating d.c voltage. There exists different types of rectifier, but for this project the bridge rectifier is used. The full-wave bridge rectifier used in this project consists of four diodes embedded as a single chip and thus has the same principle of operation.

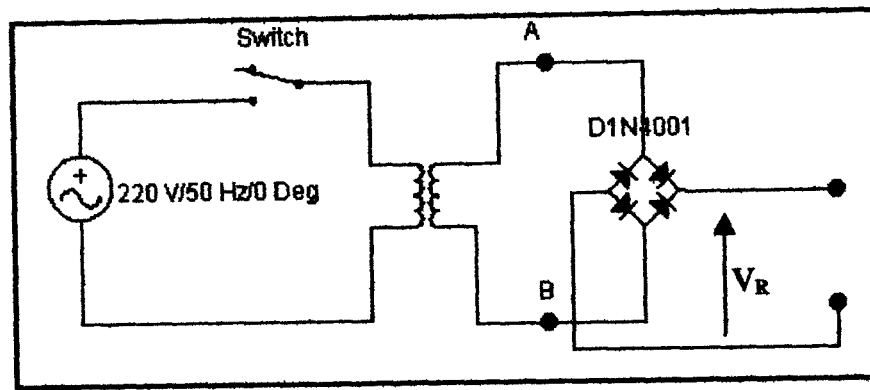

Fig. 3.7.2 Bridge rectifier circuit.

When the potential of A is positive with respect to B, diodes D1 and D3 conduct and a current flows in the load. When the potential B is positive with respect to A, diodes D2 and D4 conduct and the current in the load is in the same direction as before.

3.7.3 FILTER

The function of the filter circuit element is to remove fluctuations or pulsations (called ripples) present in the output voltage supplied by the rectifier. It has a d.c value and some a.c components called ripples. This type of output is not useful for driving sophisticated electronic circuits or devices as well as this project.

In fact, this circuit requires a very steady d.c output that approaches the smoothness of a battery's output.

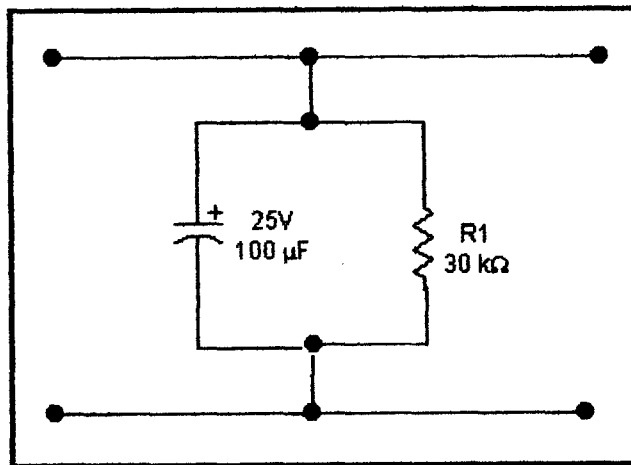

Fig.3.7.3a Filter circuit

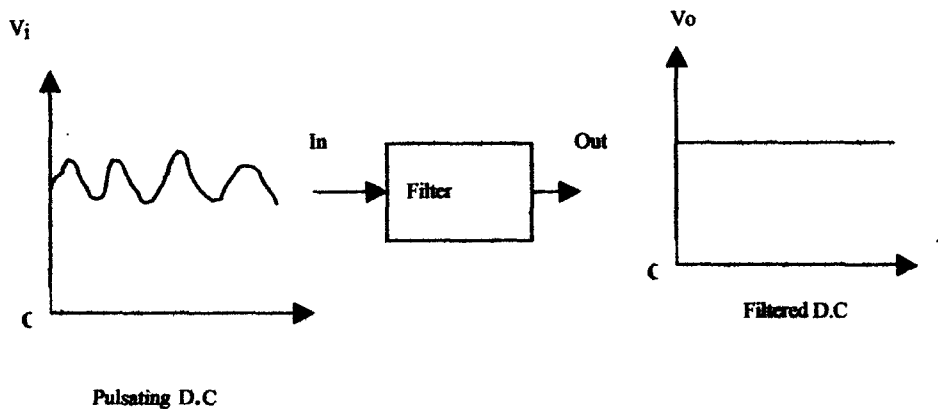

Fig.3.7.3b The main function of a filter circuit.

The ripple voltage, which occurs under this load conditions, can be calculated approximately by a triangular wave which has peak-to-peak value of $V_{r(p-p)}$ that is amount by a capacitor voltage falls during discharge period T_r .

$$V_{r(p-p)} = (I_{d.c} T_r) / C = V_{d.c} / (f_r C R_L) \dots\dots\dots(13)$$

The triangular ripple has an r.m.s value given by

$$V_{r(r.m.s)} = V_{r(p-p)}/2\sqrt{3} = V_{d.c.}/(2\sqrt{3}f_rCR_L) \dots\dots\dots (14)$$

Therefore,

$$\gamma = V_{r(r.m.s)}/V_{d.c} = 1/(2\sqrt{3}f_rCR_L)\dots\dots\dots(15)$$

Now, f_r is the frequency of the ripple voltage. For a half wave rectifier, f_r equals the rectifier line input frequency whereas it is double the line input frequency for a full-wave rectifier. And γ is the ripple factor.

Hence, for full-wave rectifier where f is the line frequency, then,

$$\gamma \approx 1/(4\sqrt{3}fCR_L)\dots\dots\dots(16)$$

Also,

$$V_{d.c} = V_{ip}[(4fCR_L)/(1+4fCR_L)] \dots\dots\dots(17)$$

Where, $V_{d.c}$ = d.c voltage across the load resistor R_L

V_{ip} = peak rectifier output voltage

R_L = load resistor.

To determine the value of the shunt capacitor given 99% ripple factor, 30Ω load resistor R_L and $V_{ip} = 12V$ at 50Hz.

From equation (16);

$$\gamma = 1/4\sqrt{3}fCR_L$$

$$0.99 = 1/(4*1.7321*50*30*C)$$

Therefore,

The shunt capacitor, $C = 1/(0.99*1.7321*4*50*30)$
 $= 97.194\mu\text{F}$

Also, the d.c voltage across the load resistor,

$$V_{d.c} = V_{ip} [(4fCR_L)/(1+4fCR_L)]$$

$$= (4*50*97.194*30*12)/(1+4*50*30*97.194)$$

$$= 11.9\text{V}$$

3.7.4 VOLTAGE REGULATOR

The main function of voltage regulator is to keep the terminal voltage of the d.c supply constant even when

- (i) a.c input voltage to the transformer varies; or
- (ii) the load varies.

The value of the voltage regulator used in this project is MC7812C, it is used to maintain the rectified voltage constant at 12volts.

Hence, regulation can be found from;

$$\% \text{regn} = [(V_{ip} - V_{d.c}) / V_{ip}] * 100 \dots \dots \dots (18)$$

Where, $V_{ip} = 12\text{V}$, $V_{d.c} = 11.9\text{V}$

Therefore, $\% \text{ regn} = [(12\text{V} - 11.9\text{V}) / 12\text{V}] * 100 = 83.3\%$

CHAPTER FOUR

CONSTRUCTION AND TESTING

4.1 CONSTRUCTION

The construction was carried out in stages i.e. one unit after the other-using a breadboard where each section of the design was built and tested to give the required signal output. Practically, all the components were transferred onto the vero-board; apart from the temperature sensor, the integrated circuit (741IC) which are prone to damage by static charges.

Accordingly, they were fitted in integrated circuit holders and were not plugged into holder until all the wiring was completed. Care was taken in the course of soldering to avoid short-circuiting. A number of link wires are needed and the capacitor checked for polarity before final soldering was carried out. The circuit set-up was tested again and then placed in a casing.

A casing measuring 25by15 by12 centimeters is an excellent choice for this project. The circuit vero-board was mounted on the rear panel using screws. Also, the transformer was mounted to the base panel of the casing using screws. Openings were made on the casing for the switch, Led indicators as well as the sensor and the heating element plug-in as shown in fig. 4.1

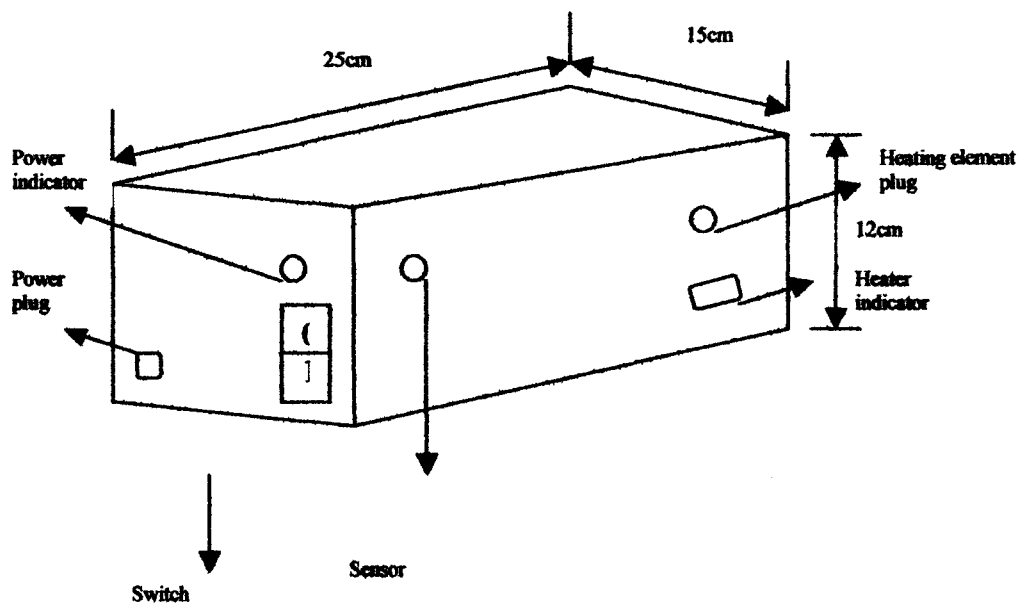

Fig.4.1 The casing

4.2 TESTING

When the unit is switched on, in calibrating the system, V_{R1} must be adjusted very carefully in order to set the reference voltage V_{ref} at a fixed value in such a way that the output voltage V_o of the comparator is not sufficient to bias the transistor T_{R1} . Hence, at this point V_{ref} is greater than V_{in} .

A more accurate method is to calibrate the unit against a precision thermometer. With the thermometer and the sensor placed side-by-side in a heating water container and allowed to settle to the same temperature for some minutes, simply adjust V_{R1} for a reading, which matches the temperature indicated by the calibration thermometer.

As temperature increase via heating, thermistor resistance falls and the V_{in} (input voltage) begins to fall until the resistance of the thermistor is equivalent with R_3 . At this point in time V_{in} has risen to half V_{cc} , and temperature sensed by the thermistor with adjustment of RV_1 is the value of the critical temperature of 60 degree Celsius as obtained by this project.

4.3 RESULTS.

Temperature is sensed via a thermistor. This is a resistor, which varies its resistance as temperature changes. The one chosen for this application is an NTC (negative temperature coefficient) type in which resistance falls as temperature rises. The resistance at room temperature of 27°C is about 10k Ω falling to about 4.8k at 60°C. This thermistor forms a voltage divider network with RV_1 And R_3 .

The familiar 741 op-amp is the basis of the analogue unit .As temperature increases thermistor resistance falls and the voltage begins to fall so that the voltage at the output of the op-amp increases.

When further heating is applied, thus increase in temperature above 60°C will cause a fall in the resistance of the sensor that makes V_{in} to fall below V_{ref} which indicate the ON/OFF of the heating element.

CHAPTER FIVE

CONCLUSION AND RECOMMENDATION

5.1 CONCLUSION

The original idea behind this project is the design and construction of a prototype thermostatic control for heating systems, which was successful as described. It is a simple functioning temperature control of heating system(s).

As the wiring is so simple there is very little that can go wrong provided all of the components are correctly positioned and well soldered. Time was spent checking for dry joints, solder bridges and incorrect component positions and values before applying power. Also, it is tasking getting the collector, emitter and the base of the transistor; which is gotten from data book.

The design is relatively simple and automated; the detection in the heating environment of the sensor is through thermionic emission. Hence, it can be conveniently used in many applications where overheating at a particular temperature is dangerous, such as in rooms, incubators, tea kettles, furnaces etc.

Finally, it can be said that the desired output at the relay switch is due to temperature variation at the thermistor, was obtained satisfactorily.

5.2 RECOMMENDATION

Sophisticated signal processing techniques in order to have a digital readout based system is recommended to bring this work toward lime-light of better temperature monitoring in many applications.

Finally, for a more sensitive and reliable system, a temperature transducer that is more sensitive than the thermistor whose resistance or factor of variation with temperature is linear should be used e.g. silicon diode transducers.

REFERENCES

1. **B.PB Publications.**
150 Circuits for the Experimenter (page 36-39).
2. **Tom Ducan And John Murray.**
Adventures with microelectronics Book Aid
International, (1998).
3. **William Hasley And Emanuel Friedman.**
Merit Students Encyclopedia Macmillian
Educational company, (1982).
4. **Barry Woolland.**
Practical Electronics (2nd Edition).
5. **M.W. Anyakoha.**
New school physics M.N.Anyakoha, (1999).
6. **Michael Tooley.**
Electronics circuits Handbook Newness, (1993).
7. **Grolier International Inc.**
Encyclopedia Americana (International Edition)
volume 13 and 14 Grolier International INC.,(1994).
8. **B.L.Theraja and A.K. Theraja.**
A Textbook of Electrical Technology (Revised Edition)
S. Chand and Companyltd, (2002).
9. **Jacob Millmann and Christos C. Halkias.**
Integrated Electronics Mc Graw-Hill, (1976).
10. **A.O.Evwaraye and E.N.Mgbenu.**
Electromagnetism and Modern Physics for physical sciences Nigeria
University physics series, (1993).
11. **Emajemite William.**
Design and construction of Electronic Thermostatic control

for heating systems.

(Project Work) Emajemite William, (2003).

12. Web sites:

[www. Electronic-circuits-diagrams.com](http://www.Electronic-circuits-diagrams.com)

[www.softcopy.co.uk/index.](http://www.softcopy.co.uk/index)

www. Electronics-projects.net

www. Designnotes.com

www.commlinx.com

www.epanorama.net