

**DESIGN OF ELECTRIC POWER NETWORK
TO A FOOTBALL FIELD
PROVIDED WITH HALOGEN LAMPS
TO
PRODUCE ILLUMINATION OF 10LUX AT
1METER INTERVAL.**

By

**ABUBAKAR .K. HALIDU
(2005/21983EE)**

**A PROJECT SUBMITTED TO THE DEPARTMENT OF ELECTRICAL AND
COMPUTER ENGINEERING, SCHOOL OF ENGINEERING AND ENGINEERING
TECHNOLOGY, FEDERAL UNIVERSITY OF TECHNOLOGY, MINNA, IN PARTIAL
FULFILMENT OF THE REQUIREMENTS OF THE AWARD OF THE BACHELOR OF
ENGINEERING (B. ENG.) DEGREE IN ELECTRICAL AND COMPUTER
ENGINEERING**

NOVEMBER 2010.

DECLARATION

I hereby declare that this work was done by me and that it has never been submitted elsewhere for the purpose of awarding degree to the best of my knowledge. I also hereby relinquish the copyright to the federal university of Technology, Minna.

Abubakar -k. Halidu

Name of student

12/11/2010

Date

CERTIFICATION

This is to certify that this project work was carried out by Abubakar Kpelafia Halidu of Matric No. 2005/21983EE of the department of Electrical and Computer Engineering in the Federal University of Technology Minna.

Prof. O. Ugo

Project Supervisor

 28/10/10

Signature and Date

Project Co-ordinator

ENGR. A. G. RAI

Head of Department

Signature and date

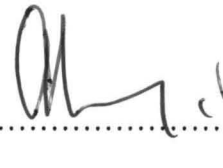
 (Jan 11, 2011)

Signature and Date

Engr. Dr. G. I. Ighalo

External Examiner

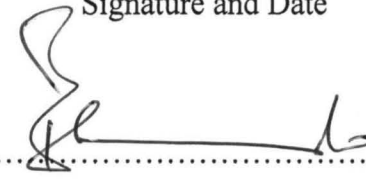
 1/12/10

Signature and date

DEDICATION

First of all, this work is dedicated to Allah (SWT), my dad Alhaji Abubakar kpelafia, my mom mallama Hafsat Abubakar, to my siblings and all who have been of great support.

ACKNOWLEDGEMENT

First and foremost, I am thankful to God, the most gracious most merciful for helping me finish this work. It is my belief in him that helped me persevere at times when it seemed impossible to go on.

I am indebted to my father and my mother for teaching me the importance of hard work and perseverance and for instilling in me the confidence that I could succeed at whatever I chose to do.

I wish to express my deep sense of gratitude and indebtedness to **Prof. Oria Usifo**, Department of Electrical/Computer Engineering, F.U.T, Minna for introducing the present topic and for his inspiring guidance, constructive criticism and valuable suggestions throughout the project work.

I am also thankful to all staff members of Department of Electrical/Computer Engineering, F.U.T Minna. I would like to express special thanks to the Engineers at the Department of works F.U.T Minna for providing me with information on the school's football field lighting Design. Lastly, I would like to thank and express my gratitude to my guardian Alh. Abdullahi Gobi, Haj. Asmau Abdullahi, malama Rabi Abdullahi for there suport, my brothers; Ilyasu Abubakar, Ibrahim Abubakar for being there and to my friends who at various stages had lent a helping hand.

ABSTRACT

A good lighting design is important both for the player's performance and for the spectators to watch the game in pleasure. In this project, lighting design for a football field which has a dimension of 120 by 60m is considered. The required number and positions of floodlights was determined as a result of lighting design to satisfy minimum lighting level on the football field. The point by point method was used to determine the illumination level on the field.

The lighting design was followed by electrical network designs which include; load balancing, lamps and cable specification, switch gear selection and the connections between them. The design also incorporate a generator incase of power outage. A market survey was carried out to get the prices of the various materials used and cost the project.

LIST OF FIGURES

Figure 2.1	Site.....	6
Figure 2.2(a)	Single stage distribution.....	7
Figure 2.2(b)	Three stage distribution.....	8
Figure 2.3	Sequence of supply control.....	10
Figure 2.4	Rewirable (Semi-enclosed) fuse (BS3036).....	13
Figure 2.5	H.R.C (BS 88 and BS 1361) fuse.....	14
Figure 2.6	Current operated earth leakage circuit breaker.....	15
Figure 2.7	ideal transformers.....	18
Figure 2.8	Area lighting.....	22
Figure 2.9	Luminance.....	23
Figure 2.10	Illuminance.....	23
Figure 2.11	Contrast.....	24
Figure 2.12	Reflectance.....	24
Figure 3.1	The required dimensions to determine illumination at point P.....	33
Figure 3.2	Pole arrangement proposed for the football field.....	34
Figure 3.3	The required dimension to determine illumination at point P with $X = X_1$	35
Figure 3.4	The required dimensions to determine illumination at point P with $X = X_2$	36
Figure 3.5	Schematic representation of MV panel.....	39
Figure 3.6	Schematic representation of MV panel for second and fifth pitch lights.....	41
Figure 3.7	Schematic representation of distribution of main distribution panel.....	43

LIST OF TABLES

Table 2.1	Uniformity recommendations for exterior lighting.....	31
Table 3.1	Results.....	37
Table 3.2	Load calculations and balancing for the first MV panel.....	38
Table 3.3	Load calculations and balancing for the second MV pane (2 nd and 5 th pitch Lights).....	40
Table 3.4	Load calculations and balancing for the second for the main distribution panel...42	
Table 4.1	Summary of result.....	45
Table 4.2	Cost table for lamp used.....	45
Table 4.3	Costing for power.....	46
Table 5.1	The overall cost of the entire materials that will be used to implement the Design.....	48

Table of Contents

Declaration.....	ii
Certification.....	iii
Dedication.....	iv
Acknowledgement.....	v
Abstract.....	vi
List of figures.....	vii
List of tables.....	viii
Chapter One: Introduction.....	1
1.1 Aims and objectives.....	2
1.2 Project motivation.....	3
1.3 Scope of study.....	3
1.4 Problem definition and methodology.....	3
1.5 Brief history.....	4
1.6 Project outline.....	5
Chapter Two: Theory of design.....	6
2.1 Site description.....	6
2.1 Power distribution.....	6
2.2.1 Incoming service cable.....	8
2.2.2 Final sub-circuits.....	8
2.2.3 Consumer control unit distribution board.....	11
2.3 Cables.....	11

2.3.1	Cable categories.....	11
2.3.1.1	Underground cable.....	12
2.3.1.2	Overhead cable.....	12
2.4	Protection.....	12
2.4.1	Method of protection.....	13
2.4.2	Earthing.....	15
2.4.3	Method of earthing.....	16
2.5	Transformer.....	17
2.5.1	Basic principle of operation.....	17
2.5.2	Feeder pillar.....	18
2.6	Illumination.....	19
2.6.1	Photometric terminologies.....	22
2.6.2	Light sources.....	26
2.6.3	Types of lamps.....	27
2.6.3.1	Principle and operation of halogen lamp.....	27
2.6.3.2	The halogen lamp principle.....	28
2.7	Metallic pole.....	28
2.7.1	Pole description.....	28
2.8	Historical perspective of point method.....	29
2.8.1	The point-by-point method.....	29
2.8.2	Calculation of illumination (lumen method).....	30
2.8.3	Illumination formulae.....	30
	Chapter Three: Design procedure.....	33

3.1	Lighting.....	33
3.1.1	The 1 st pole.....	34
3.1.2	The 2 nd and 5 th pole.....	36
3.2	Load calculation and balancing.....	37
3.2.1	Load summary.....	38
3.2.2	Load summary.....	40
3.3	Standby equipment.....	43
3.4	Cabling.....	44
3.5	Calculation of the maximum resistance of the earth electrode.....	45
	Chapter Four: Design implementation and costing.....	46
4.1	Lighting.....	46
4.3	Power.....	47
	Chapter Five:	48
5.1	Significance.....	48
5.2	Limitations.....	48
5.3	Conclusion.....	49
5.9	Suggestion for further work.....	49
	Reference.....	50
	Appendix A.....	51
	Appendix B.....	52

CHAPTER ONE

1.0 INTRODUCTION

A matter of providing an arrangement of conductors and equipment to safely and effectively transfer electric energy from a source of power to lamps, motors and other functional devices which operate on electricity. Electric Power network design could be seen as the production of standard electrical format and clear view of equipment and facilities provided in a scheme, on paper prior to the start of the actual construction work.

Concept formulation is based on thoughts, ideas and goals that are synthesized from several elements gathered from the design brief with respect to functional and site requirement into a unique parameter based on appreciation, experience not leaving out the needed design criteria.

A good lighting design is important both for the players to play the match in pleasure and to display a good performance in the game and also for the spectators to watch the match in pleasure. A good lighting design should satisfy the requirements of each of three groups of people in a football match. These are players, spectators and officials. Providing an appropriate illumination level for one group should not introduce objectionable glare into the field of view of the other two groups. The areas where football matches will be televised require a higher level of illumination. This not only ensures good broadcast conditions, but also improves vastly visibility for both spectators and participants [5].

All sports played under floodlights have a set of criteria for the illumination of the sports ground. First, the level of illumination must be as high as possible. Secondly, it must be as uniform as possible [12].

Knowing the dimensions of the football field is the first step in designing the electric power network for the field regardless of the wiring method adopted. Some parameters common to all electrical designs are thoroughly taken into consideration. Such factors include:

- a) **Safety:** Electricity if not controlled can be dangerous; hence the provision of appropriate equipment and use of quality workmanship goes a long way to minimize danger.
- b) **Economic Liability:** An uneconomical design will definitely not see the light of the day. This can be observed in the number of abandoned project all over Nigeria. Consequently, adequate economic assignment of project must be carried out before commencement.
- c) **Maintenance:** The ease of carrying out maintenance of facilities provided should be maintainable at minimum cost.
- d) **Future Expansion:** In view of the ever changing nature of man and his continuous quest for growth and development, adequate allowance must be provided in specifying the capacity of cables and distribution equipment without incurring undue cost [1].

1.1 AIM AND OBJECTIVES

This project was aimed at designing an electric power network to a football field provided with halogen lamp to produce illumination level of 10lux at 1meter interval.

The first objective was to provide light to the football field to an illumination level of 10lux at 1meter interval using halogen lamp. The second objective was to

design an electric power network to a football field taking into consideration factors such as; safety, Economic liability, maintenance, reliability.

The design will make provision for an alternative power supply for emergency lighting.

The entire lighting design must be accomplished efficiently in terms of capital and energy resource.

1.2 PROJECT MOTIVATION

The principal motivation for this project was the need for adequate illumination and the need to ensure a safe visual playing field as a challenge faced by most football fields. Lighting in football fields presents special problems when games need be played at night.

A good electric power network need be designed to supply the lamps used in illuminating the field.

1.3 SCOPE OF STUDY

This project will be limited to the complete electric power network and lighting design; the design will incorporate power, lighting, cabling as well as an alternative source of power from a generator.

1.4 PROBLEM DEFINITION AND METHODOLOGY

This project is an attempt to design an electric power network to a football field provided with halogen lamps to produce illumination level of 10lux at 1meter interval.

The process of designing involves the following:

- i. The development of site layout.
- ii. Lighting design.
- iii. The power design.
- iv. The calculation of the entire load from (i) & (ii) above.
- v. The cabling and switch gear selection.

1.5 BRIEF HISTORY

Long before the spread of modern civilization, the blessing of fire, heat and light can never be over emphasized. The use of fire was the first human utilization of energy in a form other than sunlight. It provided protection against climatic changes and thus improved the chances for survival.

Electrical lighting had its real beginning in about 1870 with this; the development of commercially usable lamps was given greater impetus nine (9yr) years later by Edison's first practical incandescent lamp. Today's electric light sources fall into three generic classifications: The incandescent lamp, the gaseous discharge lamp, and the electroluminescent sources [14].

Medical research on the effect of excessive light on human body suggest that a variety of health effects may be caused by excessive light exposure, and some lighting design textbook used human as an explicit criterion for proper lighting. Health effect of over-illumination or improper spectral composition of light may include: Increased headache incidence, Player fatigue, medically defined stress, and increased anxiety. Common levels of fluorescent lighting in offices are sufficient to elevate blood pressure by about eight points. There is evidence that light levels in football field lead to increased stress as well as increased player errors [3].

It is important to address the lighting needs of a football player which are the ultimate bases for illumination design of football fields. These needs are (1) the requirements for optimal functioning of the visual sensory system, and (2) the light need to establish an appropriate level of visibility necessary for safe, efficient performance of players [3].

It is required that in the lighting design of a football field, almost all points on the field should be at the required illumination level in compliance with the related standards. The floodlights which are to be used for the lighting of a field should be adequately chosen. Floodlights with narrow beam spread result in spotty illumination.

On the other hand, the floodlights with wide beam spread result in poor utilization and a low level of illumination, particularly in the center of the field. So, they may produce glare in the opposite stands close to the side lines [5].

There are also fundamental geometric criteria related to glare, light utilization, illumination uniformity (in three as well as in two dimensions), shadows, and stadium size. These can easily make the difference between a successful lighting project and spectator annoyance, resource waste, and even significant impacts on the players' ability to compete in the sport.

1.6 PROJECT OUTLINE

This project is divided into five chapters, chapter one is introductory chapter, chapter two deals with Theory of design, chapter three is the design procedure, and chapter four is concerned with the costing and implementation. The work is rounded up in chapter five with conclusion, limitation, recommendations, and useful suggestions for further studies.

CHAPTER TWO

2.0 THE THEORY OF DESIGN

2.1 SITE DESCRIPTION

For this project work, the football field is of the dimensions 120m by 60m with Area = 7200m².

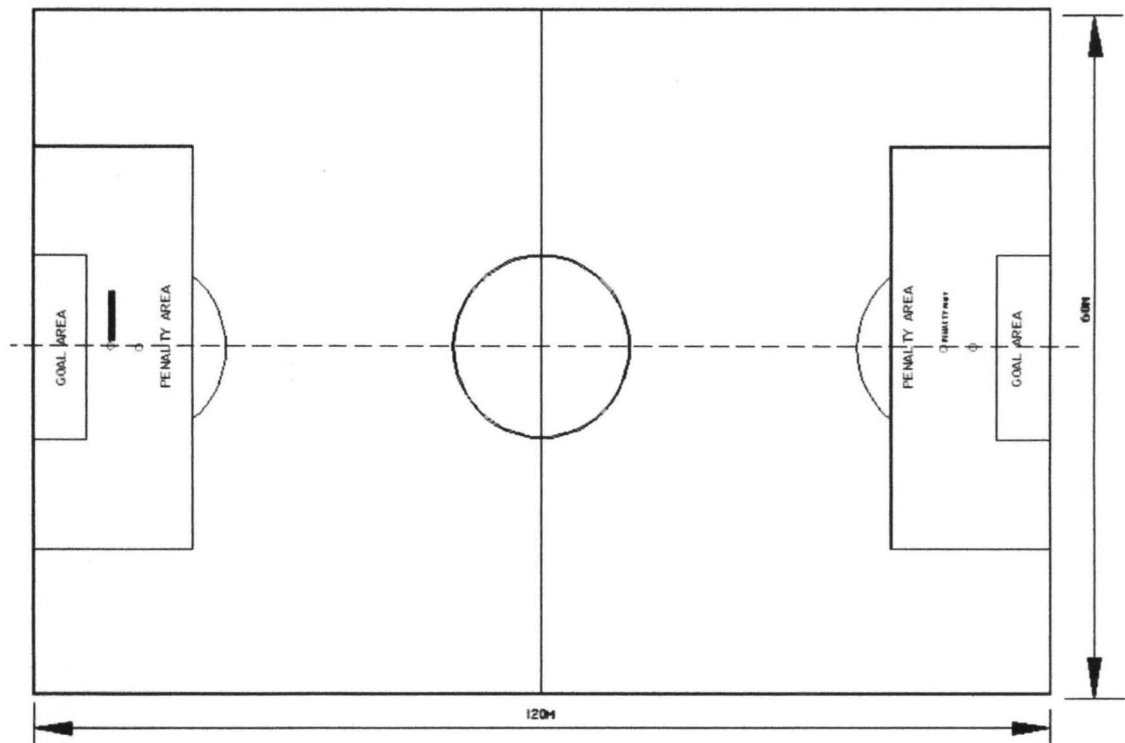

Fig. 2.1 Site

2.2 POWER DISTRIBUTION

The conductor system by means of which electric power is conveyed from a generating station to the consumer's premises may, in general, be divide into two distinct parts i.e. transmission system and distribution system. For the purpose of this project emphasis will be given to the Distribution system. PHCN-Power Holding

Company of Nigeria is the agency of the Government responsible for Generation, transmission and distribution of electricity in Nigeria. PHCN distributes power using the grid system.

PHCN'S National grid control center is at Oshogbo in Osun State of Nigeria. This center controls every other transmission and power station linked to the grid in the country. In the fig. 2.2(a), the schematic illustration of distribution of electricity from power stations transformers, transmission lines and to individuals is shown.

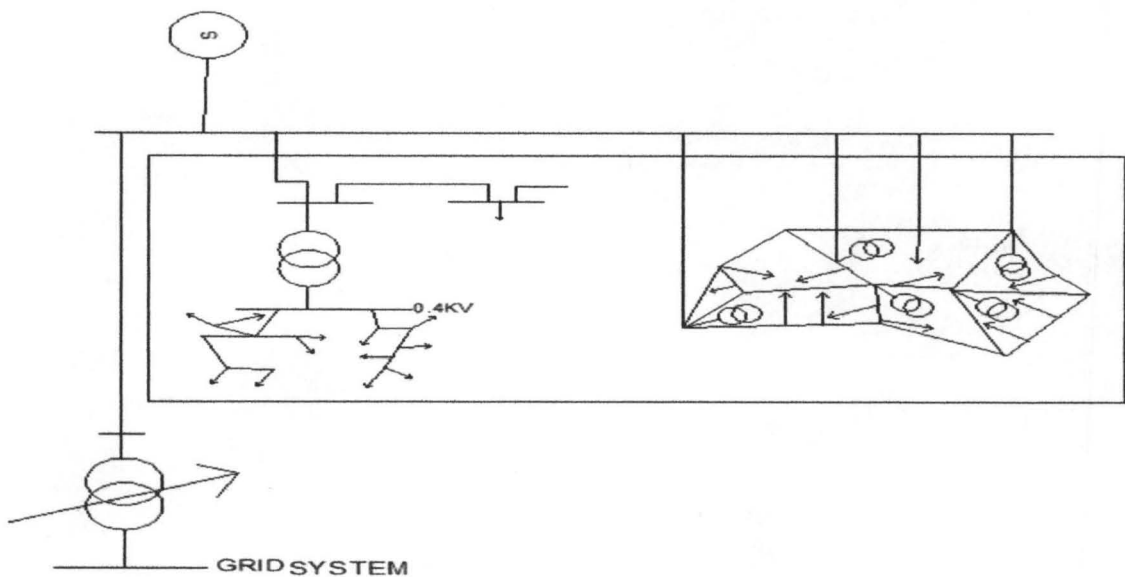

Fig. 2.2(a) Single stage distribution.

It involves the stepping down of voltage from 6-20KV to 400V, which can feed directly commercial or domestic consumers. Fig.2.2b involves three stages distribution i.e. stepping down from 132-330KV to 33KV as stage 1, then stepping down from 33KV to 6-20KV as stage 2 and finally stepping down from 6-20KV to 400/230KV as stage 3.

As said earlier on, Power station generators are produced to work between 6-20KV for economic reasons. For further transmission the generated voltage is stepped up to 132-330KV for long distant transmission as shown in the fig.2.2b [1].

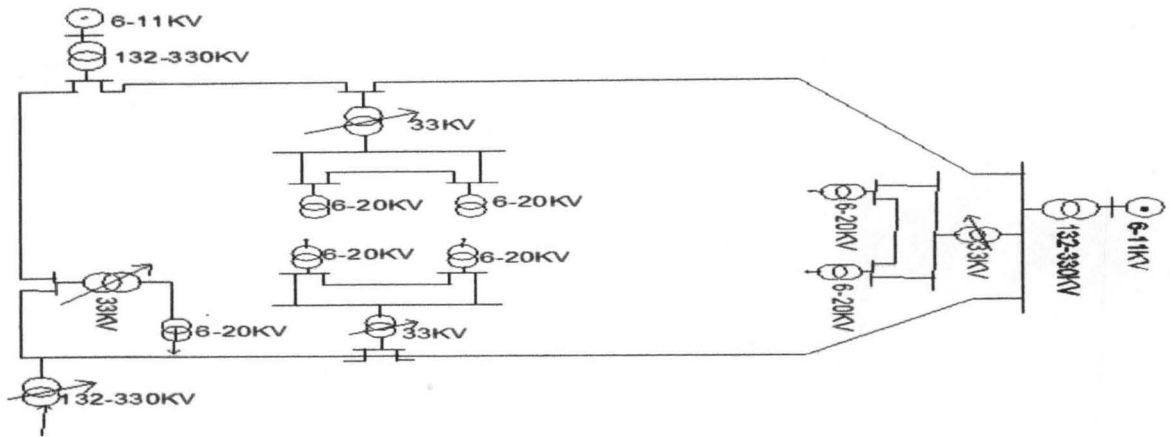

Fig. 2.2(b) three stages distribution.

2.2.1 INCOMING SERVICE CABLE

The incoming supply enters via the supply authority (PHCN) equipment to the main switch of the “link type” (i.e. a switch which breaks both poles of the supply). From the main switch, the supply is fed to a distribution board containing fuses or other suitable overload protection equipment.

2.2.2 FINAL SUB-CIRCUITS

This is a circuit which is connected to any way of a distribution fuse board, or switch fuse feeding one or more point without the intervention of a further distribution fuse board.

The cables normally used for final circuits are 1.5mm², 2.5mm² and 6.0mm², according to the nature of the circuit. Lighting is almost invariably carried out in 1.5mm² cable and power circuits to socket outlets in 2.5mm², 6.0mm² and 10mm²

cables is used for circuits to cookers, instantaneous water heaters, showers, and other large current-using equipment, such as machine tools in workshops [1].

The I.E.E Regulation has definite rules guiding final sub-circuits. The rules are necessary to ensure that wiring to sub-circuits and fuse protection is such that danger is prevented and satisfactory results are obtained.

Final sub-circuit is in the following categories:

- i. A sub-circuit with a rated capacity not exceeding 15A.
- ii. A sub-circuit with a rated capacity exceeding 15A.
- iii. A sub-circuit feeding 13A fused plugs.
- iv. A sub-circuit feeding fluorescent and other types of electric discharge lighting.
- v. A sub-circuit feeding a motor or rotating electrical machine.

The I.E.E Regulation stipulates that for a final sub-circuit of rating not exceeding 15A, the number of point that may be supplied is limited by their aggregate demand as determined. There must be no allowance for diversity. The current rating of the cable must not be exceeded [2].

Some final sub-circuits are connected directly to the distribution board while a sub-main can also be used to supply a further sub-distribution board to which other final sub-circuit is connected. In this project work, the football field has four light stands on the four corners of the field. Its sequence of supply control is shown in the figure below.

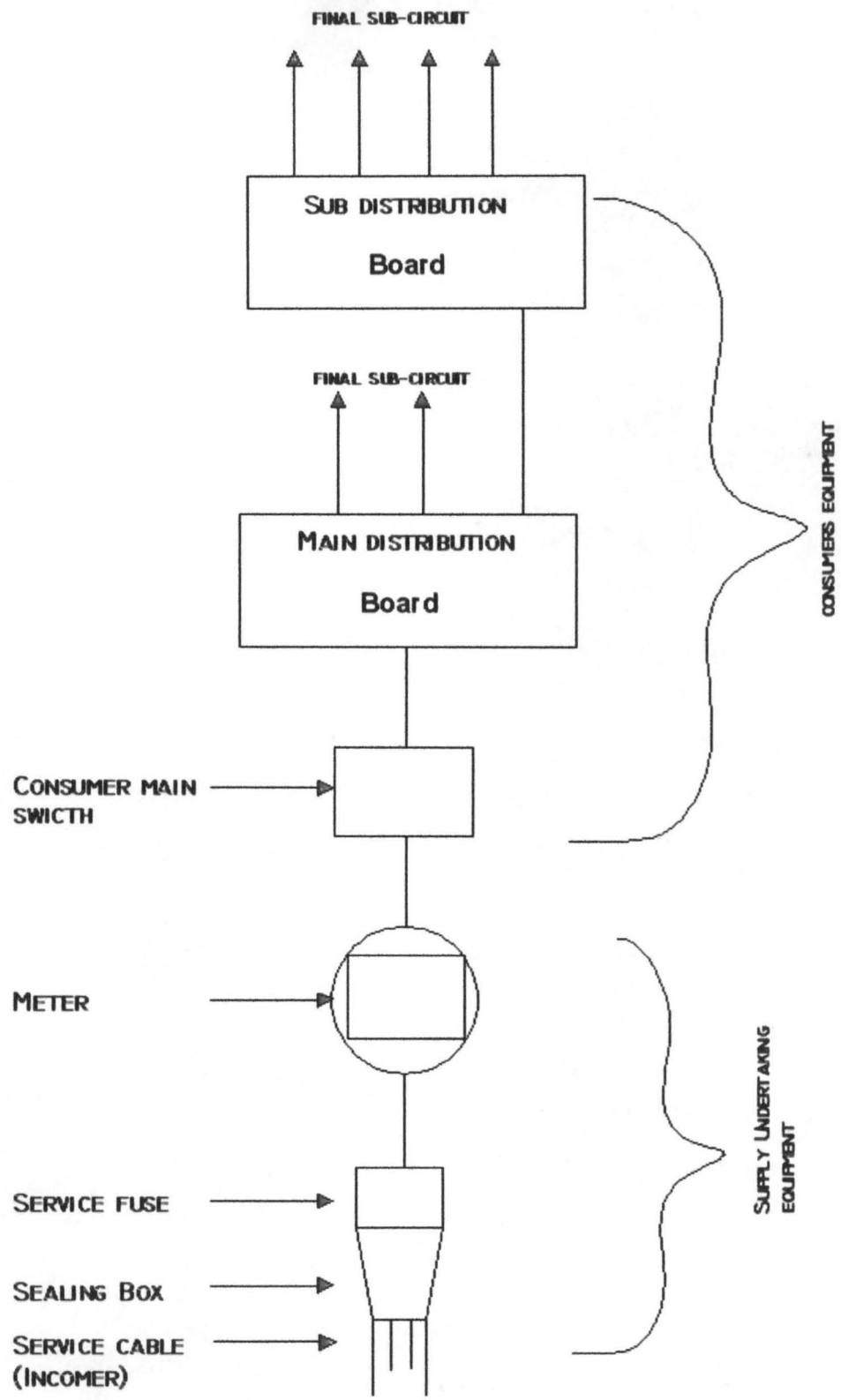

Fig. 2.3 Sequence of supply control

2.2.3 CONSUMER CONTROL UNIT DISTRIBUTION BOARD

These are usually small panels from which the final sub-circuits power supply points are taken. They are usually manufactured in standard size and the rating factors are usually indicated by the number of ways (outgoings), maximum current capacity and the number of phase's standard consumer control units in the market range from 4-way 60A to 12-way 100A SPN and 4-way 60A to 12-way 100A TPN. The ways or the outgoing are always in even numbers.

2.3 CABLES

Cables are perhaps the most important element in any electrical installation. They are the means which power is transmitted at a high voltage or current delivered to an appliance or equipment, the final consumption point.

The necessary requirement stipulated by the IEE regulation and the British standards rules of cables is that:

1. Cables should conduct electricity efficiently, cheaply and safely.
2. To this end, cable should not be too small so as to have a large internal voltage drop or too big to reduce cost.
3. Cable insulation should be such as to prevent leakage of current and minimize risk of electric shock [2].

2.3.1 CABLE CATEGORIES

Cables could be categorized according to their method of use, such as:

- Underground cables.
- Overhead cables.

2.3.1.1 UNDERGROUND CABLE

This refers to the type of electric power cable installed in underground ducts which is extensively used in cities where lack of space or considerations of safety preclude the use of overhead lines. Unlike an aerial cable, a buried cable invariably uses commercially pure copper or aluminum (mechanical strength is not a problem underground).

The types of underground cables are:

- i. T.C. cable P.J. filled unarmoured P.E. Insulated P.E sheathed aluminum screen (Application in ducts only).
- ii. TC cable (PFA) P/E. insulated P.E sheathed copper cable with aluminum. Screen steel wire 10pairs---800pairs.
- iii. PVC insulated PVC sheathed armoured 600/1000v. 1.5mm^2 --- 630mm^2 [7].

2.3.1.2 OVERHEAD CABLE

These are cables use for the supply of electric power, laid on utility poles. The types are:

- i. Aluminum conductors steel reinforced 150mm^2 AL 30/22.59mm; steel 7/2 59 (application in transmission system).
- ii. 100mm^2 (19/2.67mm \emptyset) all aluminum stranded conductor (application in distribution system).
- iii. 70mm^2 all aluminum strand PVC insulated PVC sheathed (application in domestic power supply and street light.) [7].

2.4 PROTECTION

This is defined as the process by which possible dangers arising from electrical installation works are being prevented.

The dangers are classified as:

- Overload current.
- Short circuit current.
- Earth leakage current.

In an electrical wiring system, when the above dangers are not minimized or totally prevented, the consequences may be disastrous and costly and may even involve lives of users.

The I.E.E Regulation of 14th Edition in section A and D stipulates the necessary requirements to avert dangers arising from electrical installation works.

Therefore the need for adequate electrical installation work cannot be over emphasized [8].

2.4.1 METHOD OF PROTECTION

- a. **Rewirable fuses (semi-enclosed fuses):-** fig. 2.4 describes a semi-enclosed fuse.

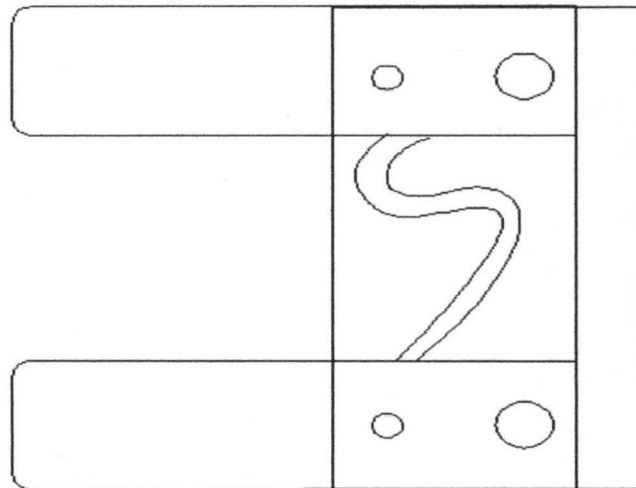

Fig. 2.4 Rewirable (semi-enclosed) fuse (BS 3036)

- b. **H.R.C (High Rupturing Capacity) fuse:** - The rewirable fuse has limited breaking capacity. If a very large current flows the fuse cable melts very rapidly and a large amount of energy is released. It can be large enough to cause serious damage to the fuse carrier. It was found

that some of this energy can be absorbed by a packing of inert fibrous or granular material wound with cable, and this led to the development of the cartridge fuse, illustrated in Fig. 2.5.

The fuse element is mounted between two end caps which form the terminals of the complete fuse link. The fuse element is surrounded by closely packed silica filler and the whole is contained in a ceramic casing. When the fuse element melts, or blows, the silica filler absorbs the energy. Fuses of this type are known variously as high rupturing capacity (HRC) or high breaking capacity (HBC) fuses or, less technically, as cartridge fuses [8].

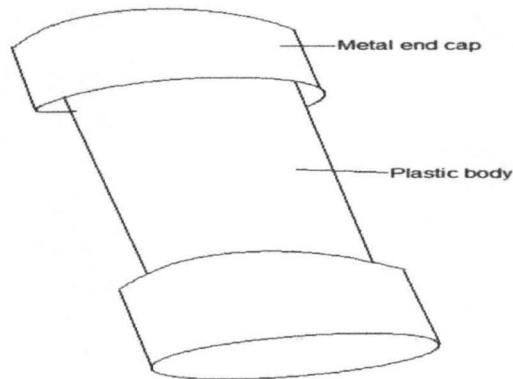

Fig. 2.5 H.R.C (BS 88 and BS 1361) fuse

- c. **M.C.B (Miniature Circuit Breaker) (BS 3871):** - a miniature circuit breaker is one which has a rating similar to that of a cartridge fuse and is about the same physical size. It differs from the fuse in the sense that it consist of no melting element.

The magnetic type is operated on the principle that the current passes through the coil and sets up an electromagnetic force which attracts the slug immersed in an oil filled cylinder. The oil delays the movement of the slug except during short circuit periods where immediate response to trip is essential, to disconnect the supply. The

on and off switching is affected by the lever which is being actuated by the slug.

The thermal magnetic type works with the principle of bimetallic action [8].

d. E.L.C.B (Earth Leakage Circuit Breaker): - The earth leakage circuit breaker is a device used to disconnect a circuit from supply, when an earth fault occurs. Fig. 2.6 describes it.

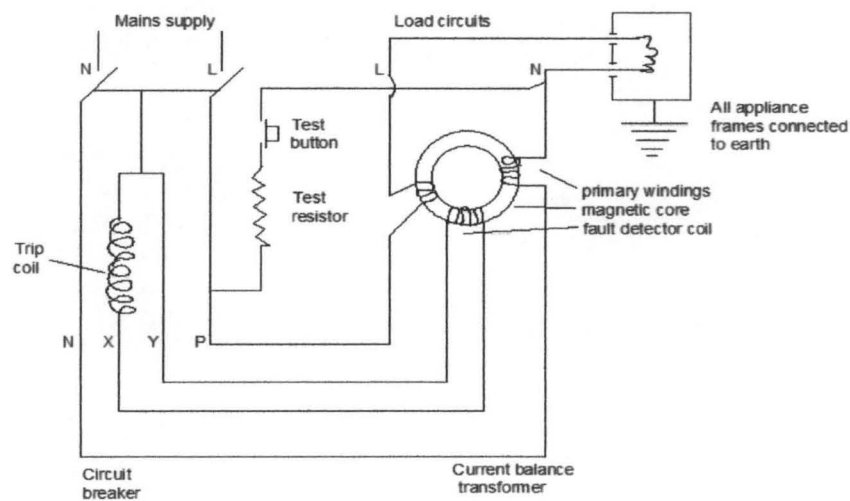

Fig. 2.6 Current Operated Earth Leakage Circuit Breaker

2.4.2 EARTHING

When insulation materials become damaged or if wire becomes displaced any metal work directly in contact with the electrical wiring system could become live. If such metal is touched there could be serious electric shock. Earthing of metal work prevents the risk of shock so that a heavy current flows to earth.

IEE regulation stipulates that every means of earthing and every protective conductor shall be selected and erected so as to satisfy the requirements of these

regulations for the safety and super functioning of the associated equipment of the installation.

The reason for earthing being among others is for:

- a. Personal protection
- b. Equipment protection
- c. Correct functioning of equipment
- d. Reliability of electrical services s

A good connection to earth should have a low electrical resistance, good corrosion resistance, ability to carry high current repeatedly and ability to perform above functions over a along period of time. Some factors exist which affect a good earthing system and these must be considered always. These include:

The soil types, moisture content and earth temperature. The IEE regulation and British standard codes thus recommend the following earth electrodes for installation.

- a. Earth rods or pipes.
- b. Earth tapes or wires.
- c. Earth plates.
- d. Earth electrodes embedded in foundation.
- e. Metallic reinforcement of concrete.
- f. Metallic pipe.
- g. Lead sheaths.

2.4.3 METHODS OF EARTHING

The IEE regulation states that every installation must have earth cables which are wires normally 2.5mm^2 (minimum) cross sectional area. The earthing wires must

be so fixed to the installation such as water, gas, lighting system. It recommends the following methods of earthing:

- a. Deep driven earth rod electrodes.
- b. Parallel driven earth rod.
- c. Buried conductors.
- d. Buried earth plates or mats.

2.5 TRANSFORMER

A transformer is a device that transfers electrical energy from one circuit to another through inductively coupled conductors—the transformer's coils. A varying current in the first or primary winding creates a varying magnetic flux in the transformer's core, and thus a varying magnetic field through the secondary winding. This varying magnetic field induces a varying electromotive force (EMF) or "voltage" in the secondary winding. This effect is called mutual induction.

2.5.1 BASIC PRINCIPLE OF OPERATION

The transformer is based on two principles: firstly, that an electric current can produce a magnetic field (electromagnetism), and, secondly that a changing magnetic field within a coil of wire induces a voltage across the ends of the coil (electromagnetic induction). Changing the current in the primary coil changes the magnetic flux that is developed. The changing magnetic flux induces a voltage in the secondary coil.

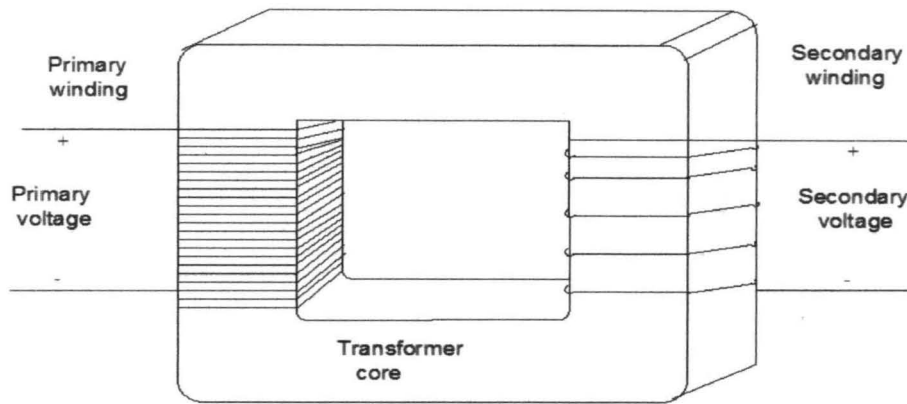

Fig. 2.7 Ideal Transformer

An ideal transformer is shown in figure 2.7. Current passing through the primary coil creates a magnetic field. The primary and secondary coils are wrapped around a core of very high magnetic permeability, such as iron, so that most of the magnetic flux passes through both the primary and secondary coils.

The transformer can be categorized as:

- Step-down transformer.
- Step-up transformer.

For this project, a step-down transformer which will step-down voltage from 33/11kv to 400v will be used.

2.5.2 FEEDER PILLAR

Feeder pillars provide a safe, flexible solution with individual monitoring and protection, ensuring efficient management of the LV electrical distribution network. The feeder pillar can be either transformer mounted to form part of a compact substation or freestanding and cable connected. Technical details include:

- Technically advanced moulded case and air circuit breakers up to 3200A
- Range of cassette mounted 'plug-on' Compact NSX up to 630A

- Stacked bus bar system up to 3200A
- Compact moulded case breakers rated over 630A
- Master pact NW air circuit breakers with solid copper bus bar connections

2.6 ILLUMINATION

The usual method of producing artificial light consists in raising a solid body or vapor to incandescence by applying heat to it. It is found that as the body is gradually heated above room temperature, it begins to radiate energy in the surrounding medium in the form of electromagnetic waves of various wavelengths. The nature of this radiant energy depends on the temperature of the hot body. Thus, when the temperature is low, radiated energy is in the form of heat waves only but when a certain temperature is reached, light waves are also radiated out in addition to heat waves and the body becomes luminous. Further increase in temperature produces an increase in the amount of both kinds of radiations but the colour of light or visible radiation changes from bright red to orange, to yellow and then finally, if the temperature is high enough, to white. As temperature is increased, the wavelength of visible radiation goes on becoming shorter. It should be noted that heat waves are identical to light waves except that they are of longer wave length and hence produce no impression on the retina. Obviously, from the point of view of light emission, heat energy represents so much wasted energy.

The ratio (energy radiated out in the form of light)/ (total energy radiated out by the hot body) is called the radiant efficiency of the luminous source and, obviously, depends on the temperature of the source. As the temperature is increased beyond that at which light waves were first given off, the radiant efficiency increases, because light energy will increase in greater proportion than the total radiated energy.

When emitted light becomes white i.e., it includes all the visible wavelengths, from extreme red to extreme violet, then a further increase in temperature produces radiation which are of wave length smaller than that of violet radiations. Such radiations are invisible and are known as ultra-violet radiations. It is found that maximum radiant efficiency would occur at about 6200⁰C and even then the value of this maximum efficiency would be 20%. Since this temperature is far above the highest that has yet been obtained in practice, it is obvious that the actual efficiency of all artificial sources of light i.e. those depending on temperature incandescence, is low.

Illumination is defined as a measure of light from a source at normal incidence on a surface. Its unit is the LUX (Ix) which is the illumination produced by 1 lumen per square meter.

Illumination technology has become a highly specialized subject which is divided into three broad areas namely:

- i. Interior illumination of buildings for living and working.
- ii. Exterior illumination for some sport stadia.
- iii. Illumination of streets and public highways.

For this project, Exterior Lighting Design technique is used. The design process for the floodlighting of functional areas normally consists of three stages:

- (a) A practical assessment was conducted to:
 - (i) Locate floodlights,
 - (ii) Select the type of light distribution, and
 - (iii) Identify the light source characteristics which suit the particular application.

(b) Lumen calculation is carried out to establish the number and loading of lamps to achieve the required average illuminance.

(c) When necessary, point-by-point calculations are performed to determine the aiming pattern of floodlights for the required uniformity.

Good lighting is important in a football field for efficient, Safe and convenient playing conditions.

The basic requirements of a good lighting for night football are:

- i. Adequate illumination to meet the demands of particular class of play and the maximum spectator viewing distance.
- ii. Correct distribution and focusing of the floodlights to ensure the best utilization of light with maximum ease of sight for players, spectators, and officials.
- iii. Uniform light level on the football field, and proper quality of light.

It is required that in the lighting design of a football field, almost all points on the field should be at the required illumination level in compliance with the related standards. Generally, the distance between the spectators and the play is the first point to be considered in determining the first point to be considered in determining the lighting requirements. Secondly, the seating capacity of the stands should be adequately chosen. Floodlights with narrow beam spread result in spotty illumination. On the other hand, the floodlights with wide beam spread result in poor utilization and low level of illumination, particularly in the center of the field. So, they may produce glare in opposite stands close to the side lines.

In an outdoor lighting system, the luminaires are usually located around the perimeter of the area to be illuminated and light beams are directed inwards as shown in Fig. 2.8. Most floodlighting installations use either tungsten halogen or high intensity discharge lamps in trough reflectors.

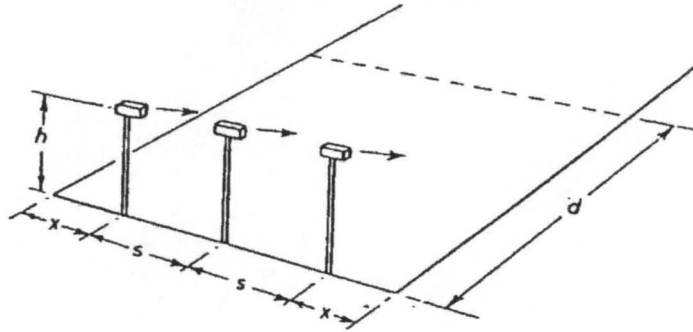

Fig. 2.8 Area Lighting

2.6.1 PHOTOMETRIC TERMINOLOGIES

To understand illumination technology, we need to define the terms used.

- a. **Solid angle (Ω):** - This is the angle subtended at the centre of a sphere by a surface area of the sphere. The unit solid angle is the Steradian which is the solid angle subtended at the centre of a sphere by an area equal to the square of the radius. A whole sphere subtends a solid angle equal to 4 steradians at its centre.
- b. **Luminous Intensity (I):** - Light intensity or illumination power is a measure of brightness of light emitted by a source in a given direction. It is measured in candle power or candela (cd). The candela is defined as $1/60^{\text{th}}$ of the luminous intensity per square centimeter of a blackbody radiator at the temperature of solidification of platinum.
- c. **Luminous Flux (F):** - This is the amount of light radiated from a source. It is measured in lumen (lm). A lumen is the luminous flux emitted within a solid angle from a light source having a uniform luminous intensity of I candela. The luminous flux emitted by a point source of luminous intensity of I

candela is 4th lumens. The efficiency of an electrical lamp is measured in lumens per watt.

- d. Luminance (L):** - This is a measure of brightness of a source of light or intensity of light reflected from a surface. It is measured in candela per square meter. For a point source illuminating a special surface area (S): $L = I/S = I/4\pi d^2 = E/4\pi lm$.

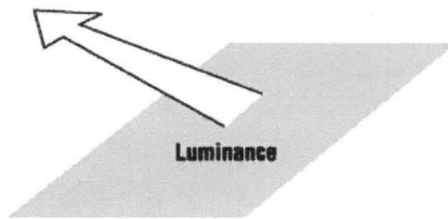

Fig. 2.9 Luminance

- e. Luminaire:** - The complete lighting assembly, less the support assembly. For purposes of determining total light output from a luminaire, lighting assemblies which include multiple unshielded or partially shielded lamps on a single pole or standard shall be considered as a single unit.
- f. Illuminance:** - Illuminance is the amount of light falling on a surface. The unit of measurement is lux (lx) and lumen /min² the SI system (or lumens per square meter = 10.76 foot candles, fc). A light meter is used to measure it. Readings are taken from several angles and positions.

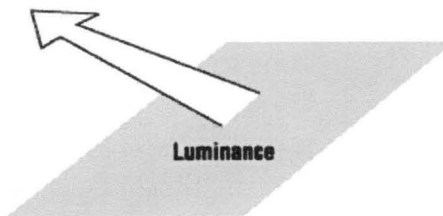

Fig. 2.10 Illuminance

- g. Glare:** - This is caused by light from a source or a reflecting surface is too bright. There are two types of glare: disability glare and discomfort glare.

Disability glare is defined as glare resulting in decreased visual performance and visibility. The cause is stray light which enters the eye and scatters inside. This produces a veiling luminance over the retina, which has the effect of reducing the perceived contrast of the objects being viewed. Discomfort glare causes fatigue and pain caused by high and non-uniform distributions of brightness in the observer's field of view.

- h. Contrast:** - The relative difference in luminance between two adjacent surfaces. In other words, how bright one surface looks compared to the other or the background against which it is being viewed.

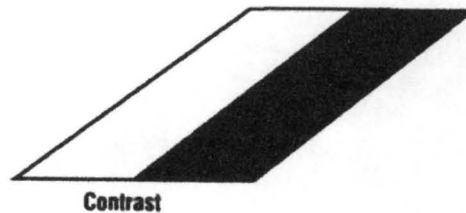

Fig. 2.11 Contrast

- i. Reflectance:** - This is the ratio of reflected luminous flux to incident luminous flux. In other words, the ratio of light energy reflected from a surface to the amount striking it. Objects with higher levels of reflectance will appear brighter than those of lower reflectance under the same lighting conditions.

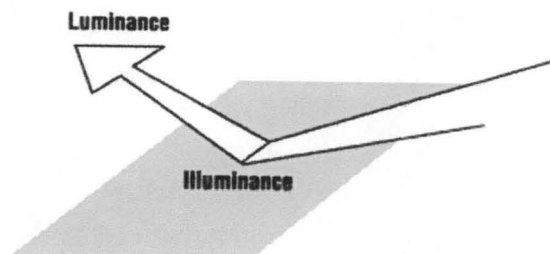

Fig. 2.12 Reflectance

- j. Flood or spotlight:** - Any light fixture or lamp that incorporates a reflector or a refractor with a diffusing glass envelope to concentrate the light output into a directed beam in a particular direction.
- k. Horizontal Illuminance:** - The measure of brightness from a light source, usually measured in foot-candles or lumens, which is taken through a light meter's sensor at a horizontal position on a horizontal surface.
- l. Vertical Illuminance:** - The measure of brightness from a light source, usually measured in foot-candles or lumens, which is taken through a light meter's sensor at a vertical position on a vertical surface.
- m. Uniformity Ratio:** - It describes the uniformity of light levels across an area. This may be expressed as a ratio of average to minimum or it may be expressed as a ratio of maximum to minimum level of illumination for a given area.
- n. Direct Illumination:** - Illumination resulting from light emitted directly from the lamp, off of the reflector or reflector diffuser, or through the refractor or diffuser lens, of a luminaire.
- o. Lighting Fixture:** - The assembly that houses the lamp or lamps and can include all or some of the following parts: housing, a mounting bracket or pole socket, a lamp holder, ballast, a reflector or mirror, and/or a refractor or lens.
- p. Full Cutoff Light Fixture:** - A luminaire light distribution where no light is emitted above the horizontal, and where the intensity at 80 degrees from nadir is no greater than 100 candela per 1000 lamp lumens.
- q. Height of Luminaire:** - The height of a luminaire shall be the vertical distance from the ground directly below the centerline of the luminaire to the lowest direct-light-emitting part of the luminaire.

- r. **Nadir:** - when used in lighting, the point directly below the center of the luminaire.
- s. **Point Method:** a lighting design procedure for predetermining the illuminance at various locations in lighting installations, by use of luminaire photometric data.
- t. **Differences between lumens and lux:** - The difference between the unit's lumen and lux is that the lux takes into account the area over which the luminous flux is spread. A flux of 1000 lumens, concentrated into an area of one square metre, lights up that square metre with an illuminance of 1000 lux. The same 1000 lumens, spread out over ten square meters, produce a dimmer illuminance of only 100 lux.
- u. **Foot-candle, FC:** - the unit of illuminance when the foot is taken as the unit of length. It is the illuminance on a surface one square foot in area on which there is uniformly distributed flux of one lumen, or the illuminance produced on a surface all points of which are at a distance of one foot from a directionally uniform point source of one candela [3].

2.6.2 LIGHT SOURCES

A football field is illuminated by natural light (day light) in the daytime and artificial light at night. The characteristics of a good light source are:

- i. Absence of glare
- ii. Acceptable colour
- iii. Noise free
- iv. Low cost

2.6.3 Types of Lamps

The types of lamps available for lighting designs can be categorized as following:

- i. Incandescent lamp.
- ii. High intensity discharge (HID) lamps (operating life is between 10,000-24,000 hours).
- iii. Energy saving lamps (these are special lamps which are usually compact long are, low pressure mercury discharge lamps).

Some of these types of lamps are intended for HF operations, which enables controllable light output and operation on ac or dc supplies with wide range of voltages.

For this project, halogen lamp will be used. It provides a small, highly efficient white light source with excellent colour rendering unlike standard incandescent lamps. Halogen lamps use a halogen gas, which allows the bulb to burn more intensely without sacrificing life and in a more compact dimension halogen offers a higher CRI than incandescent.

2.6.3.1 PRINCIPLE AND OPERATION OF HALOGEN LAMP

The light generation mechanism of the Halogen lamp is the same as that of a common incandescent (GLS) lamp i.e. an electrical current passing through a filament of relatively high resistance heats it to a glowing condition (incandescence). A part of the total energy radiated is visible light.

The higher the current passing through the filament, the higher its temperature. This in turn increases the portion of visible light and ultraviolet radiation per unit of electrical power (Watt) consumed by the lamp and the 'whiteness'.

2.5.3.2 THE HALOGEN LAMP PRINCIPLE

The Halogen lamp principle is conceptually simple. Halogen gas is added to the gas filling of these lamps. This Halogen gas combines with the evaporated tungsten filament to form tungsten-halide molecules. The lamp is constructed in such a way that the wall temperature of the glass bulb remains above 250° C. By doing this the tungsten-halide molecules are prevented from condensing on the inner bulb wall.

As a result, the wall remains clean. However the tungsten-halide molecules migrate close to the filament and this causes them to dissociate into tungsten and Halogen gas; the tungsten is deposited on the filament and the Halogen is freed; hence both are available to repeat the cycle. Unfortunately the process is not exactly regenerative. The temperature at which the dissociation (and thus the redeposition) occurs is lower than the temperature of vaporisation. Thus the tungsten atoms move away from the hottest part of the filament towards the ends which are cooler. This leads to a thin spot which ultimately causes lamp failure (in the same way as in a GLS lamp). The Halogen cycle results in the lamp characteristics remaining much more constant than in a GLS lamp (i.e. better lamp lumen maintenance).

2.7 METALLIC POLE

These are steel columns with diameters ranging from 100mm to 150mm and height 10m to 30m that floodlights are mounted upon.

2.7.1 POLE DISCRIPTION

- The poles are designed in accordance with ILE TR7.
- They are hot dip galvanized after fabrication in accordance with BS EN ISO 1461, subsequent painting might follow.

2.8 HISTORICAL PERSPECTIVE OF THE POINT METHOD

As noted in the terminology section, the 'point method' is a procedure for predetermining the illuminance at various locations in lighting installations, by use of luminaire photometric data. This is the approach adopted here. In the late 1960's, computational power was just beginning to become available. The Illuminating Engineering Society wrote the following about the point method in 1969: "Calculation methods make it possible to pre-determine the foot candle (lux) distribution provided by any given aiming pattern. However, because such calculations are long and tedious, it is general practice to base spotting or aiming diagrams. On scale plots of the beam spread and the area to be lighted, previous calculations, and practical experience.

2.8.1 THE POINT-BY-POINT METHOD

The illuminance values for a uniformity check are calculated using the point-by-point method. The inverse square law and cosine law are used to calculate illuminance at a point from intensity data.

A floodlight of mounting height h lights up the point p , as shown in Fig. 2.17, the horizontal illuminance (E) is given as follows:

$$E = \frac{I \cos\theta}{d^2} \dots\dots\dots (2.1)$$

Where I is the illuminous intensity in the direction of point p in fig. 2.17.

Since

$$h = d \cos\theta \dots\dots\dots (2.2)$$

Therefore,

$$E = \frac{I \cos^3 \theta}{h^2} \dots\dots\dots (2.3)$$

Taking maintenance factor (MF) and atmospheric loss (AL) into account, Eqn. (2.3) is rewritten as:

$$E = \frac{I \times AL \times MF \times \cos^3 \theta}{h^2} \dots\dots\dots (2.4)$$

2.8.2 CALCULATION OF ILLUMINATION (LUMEN METHOD)

The illuminations engineering societies (IES) defines light as “visually evaluated radiant energy” or better still, a form of energy that permits us to see. The most frequently used method of calculating illumination is the lumen method.

2.8.3 ILLUMINATION FORMULAE

The formula for obtaining the total number of lumens required for types of environment is as follows:

$$\text{Total lumens} = \frac{\text{Luminance} \times \text{Area of Working Plane}}{\text{MF} \times (\text{m}^2)} \dots\dots\dots (2.1)$$

From the above,

$$\text{Luminance } E = \frac{\text{Total Lumen (lm)} \times \text{MF} \times \text{CU}}{\text{Area (m}^2)} \dots\dots\dots (2.2)$$

Also the formula for obtaining the total number of lamps required for a given illumination level is as follows:

$$\text{Number of lamps, } N = \frac{\text{Total Lumens}}{\text{Luminous Flux}} = \frac{F}{\phi} \dots\dots\dots (2.3)$$

Where:

Area = Area of Working Plane (m²)

MF = Maintenance Factor

CU = Coefficient of Utilization.

Φ = Luminous Flux per Lamp or Lumen/Lamp (lm).

Table 2.1 Uniformity Recommendations for Exterior Lighting

Application	Uniformity of illuminance in critical plane of measurement		Minimum distance over which 20 % change in illuminance occurs, m
	max : min	av : min	
Non-critical areas: parks, gardens, amenity lighting	50 : 1	-	-
Working areas Most building facades Sports training areas	20 : 1	10 : 1	2
Even lighting of plain light-coloured surfaces Spectator sports areas	10 : 1	5 : 1	3
Filming and television	3 : 1	1.5 : 1	4

Football involves a combination of aerial and ground play. According to the IES, it requires ‘adequate’ lighting to 50 feet above ground. Adequate uniformity is attained when “...the ratio of maximum to minimum illumination does not exceed 3

to 1...” (IES, 1961). A principal reason for this is that flying balls appear to accelerate on passing from light to dark space. This can cause the player’s judgement of trajectories to be distorted.

CHAPTER THREE

3.0 DESIGN PROCEDURE

3.1 LIGHTING

For the football field the following was assumed.

1. Height of pole(h): 15m
2. Length and width of the field are 120m and 60m respectively.

The lighting requirement is;

- Average illuminance (E_p) at the center should be: 10lux.

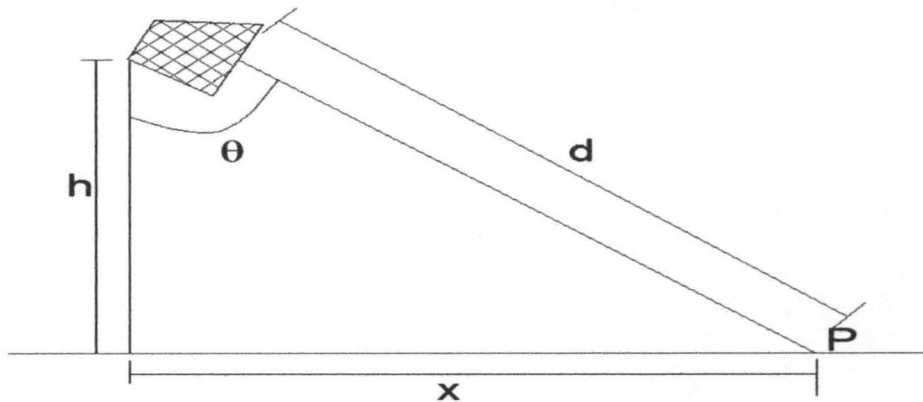

Fig. 3.1 the required dimensions to determine illumination at point P

Where: h = the height of pole.

d = distance of the reference point P from the lamp source.

x = distance of the point P to the foot of pole.

$$\text{Distance on field (d)} = \sqrt{(x^2 + h^2)}$$

$$\text{Cos } \theta = (h / d)$$

$$\text{Luminous intensity (I)} = \frac{\text{illuminance} \times \text{distance}}{\text{Cos } \theta} = \frac{E \times d^2}{\text{Cos } \theta} \dots\dots\dots (1)$$

$$\text{Luminous flux } \phi_{\text{total}} = 4 \times \pi \times I \dots\dots\dots (2)$$

$$\text{Number of lamps} = \frac{\text{total luminous flux}}{\text{Luminous flux/lamp} \times \text{number of lamps/pole}} = \frac{\phi_{\text{total}}}{\phi_L \times n} \dots\dots\dots (3)$$

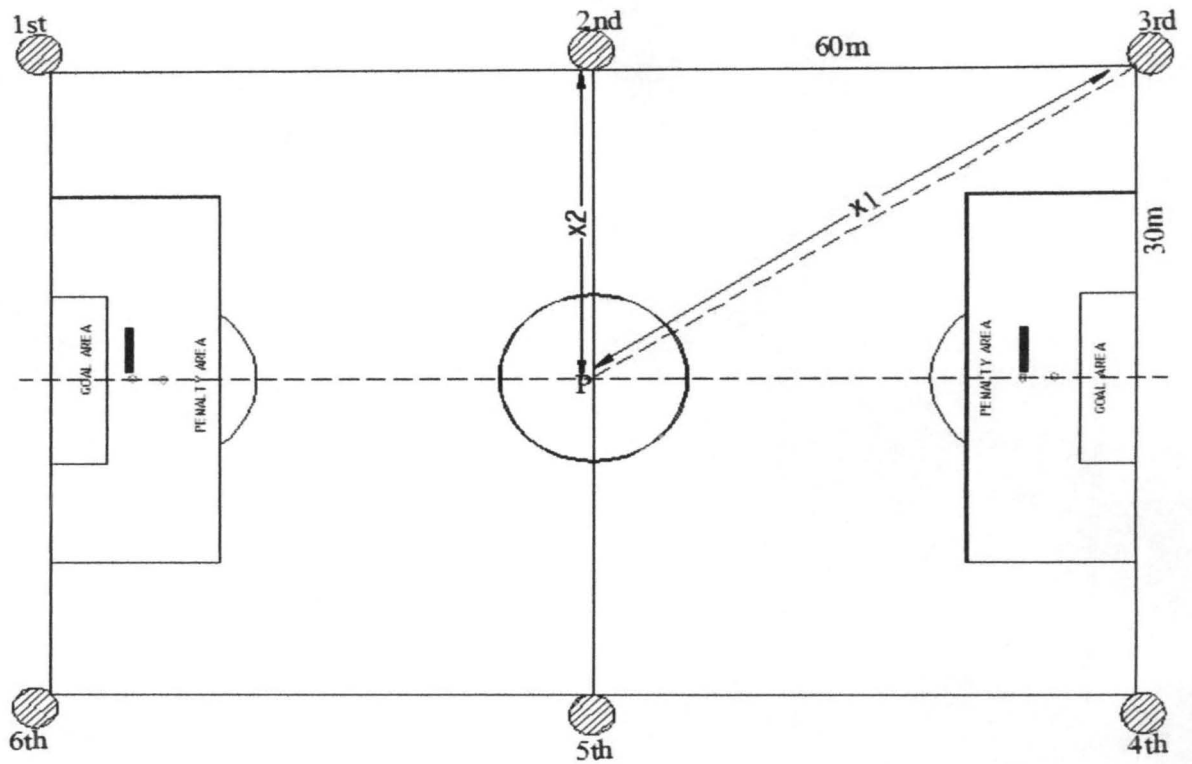

Fig. 3.2 Pole arrangement proposed for the football field

X_1 and X_2 are distances as shown in the figure above and there values are:

$$X_1^2 = 60^2 + 30^2 = 4500$$

$$X_1 = \sqrt{4500}$$

$$X_1 = 67\text{m.}$$

$$X_2 = 30\text{m.}$$

3.1.1 THE 1ST POLE

$$d^2 = x_1^2 + h^2$$

$$d^2 = 67^2 + 15^2$$

$$d = \sqrt{4714}$$

$$d = 69\text{m.}$$

$$\cos \theta = h/d$$

$$\cos \theta = 15/69$$

$$\cos \theta = 0.21739$$

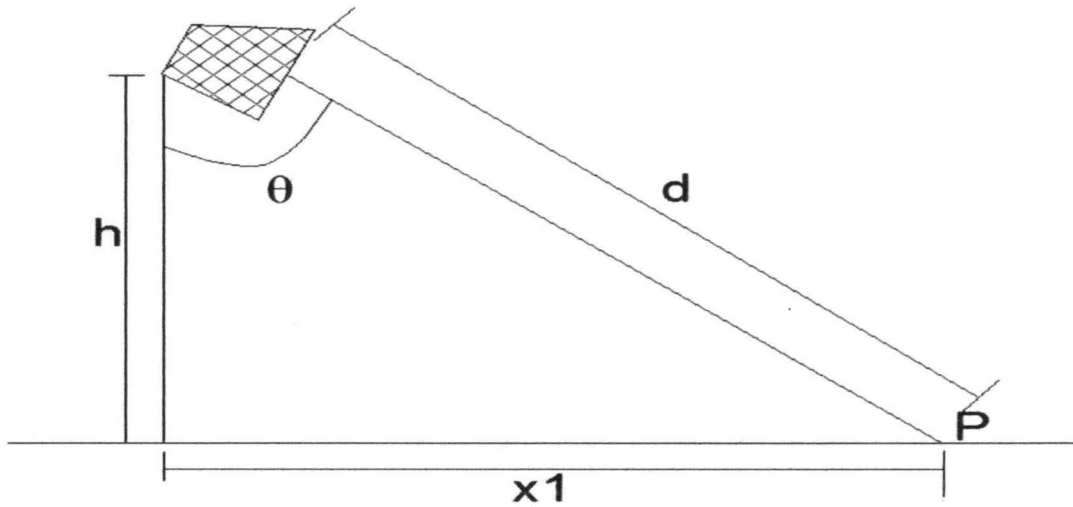

Fig. 3.3 the required dimensions to determine illumination at point P with $X = X1$

The illumination at P (E_{p1}) is 1.25lux so the luminous intensity I is;

From equation (3)

$$I = \frac{E \times d^2}{\cos \theta} = \frac{1.25 \times 4714}{(0.21739)}$$

$$I = 27105.66\text{cd}$$

$$\text{Total flux } \Phi_{\text{total}} = 4 \times \pi \times 27105.66$$

$$\text{Total flux } \Phi_{\text{total}} = 340619.8$$

Lamp type: Philip 1500T3 Q/CL DE 34000 lumen, halogen lamp.

$$\text{Number of lamps } N = 340619.8 / 34000 = 10\text{lamps}$$

The illuminance (E) produced by 1st, 3rd, 4th, 6th poles to point P are equal i.e.

$$E_{p1} = E_{p3} = E_{p4} = E_{p6} = 1.25\text{lux.}$$

3.1.2 THE 2ND AND 5TH POLE

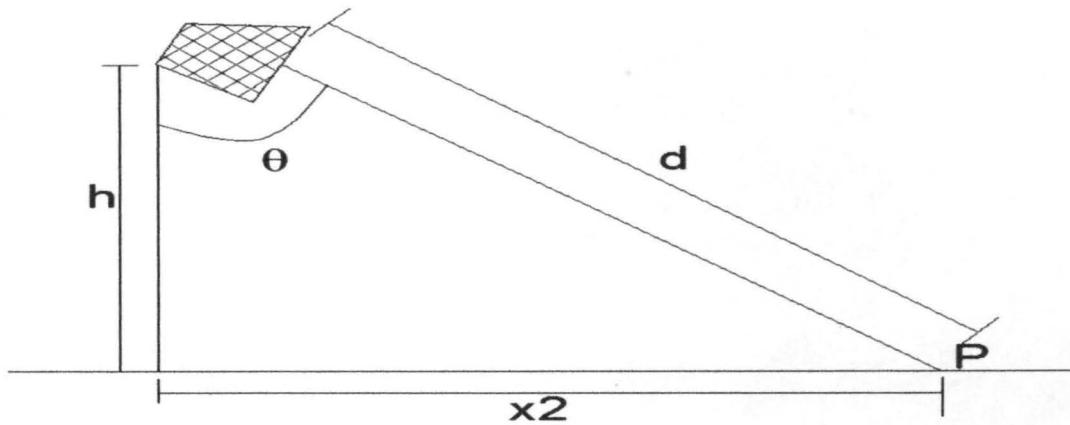

Fig.3.4 the required dimensions to determine illumination at point P with $X = X_2$

$$X_2 = 30\text{m}$$

$$d^2 = x_2^2 + h^2$$

$$d^2 = 30^2 + 15^2$$

$$d = \sqrt{1125}$$

$$d = 34\text{m.}$$

$$\cos \theta = h / d$$

$$\cos \theta = 15/34$$

$$\cos \theta = 0.44118$$

The illumination at P (E_{p2}) is 2.5lux so the luminous intensity I is;

From equation (3)

$$I = \frac{E \times d^2}{\cos \theta} = \frac{2.5 \times 1125}{(0.44118)}$$

$$I = 6375\text{cd.}$$

$$\text{Total flux } \Phi_{\text{total}} = 4 \times \pi \times 6375$$

$$\text{Total flux } \Phi_{\text{total}} = 80110.6$$

Lamp type: Philip 1500T3 Q/CL DE 34000 lumen, halogen lamp.

$$\text{Number of lamps } N = 80110.6 / 34000 = 2 \text{ lamps.}$$

The illuminance $E_{p2} = E_{p5} = 2.5\text{lux}$ as they are typical, E_{p2} , E_{p5} are for the 2nd and 5th poles respectively.

Hence, the total illuminance at point P (E_p) = $E_{p1} + E_{p2} + E_{p3} + E_{p4} + E_{p5} + E_{p6}$

$$E_p = 1.25 + 2.5 + 1.25 + 1.25 + 2.5 + 1.25$$

$$E_p = 10\text{lux.}$$

Table 3.1 Result

Pitch Light	Illuminance (lux)	number of lamp
1 st	1.25	10
2 nd	2.5	2
3 rd	1.25	10
4 th	1.25	10
5 th	2.5	2
6 th	1.25	10
Total	10	44

3.2 LOAD CALCULATION AND BALANCING

The following calculations are based on IEE Regulation and from practice.

Nominal phase voltage = 230V

Three phase Voltage = 415V

Power factor (Cos ϕ) = 0.8 lagging.

Power (P) = $\sqrt{3} \times I \times V \times \text{Cos } \phi$

Table 3.2: load calculation & balancing for the first Medium Voltage (MV) panel

CIRCUIT	No. of lamps	TOTAL LOAD (W)	LOAD ESTIMATE (watt)		
			RED PHASE	YELLOW PHASE	BLUE PHASE
L1	1	1500	1500		
L2	1	1500		1500	
L3	1	1500			1500
L4	1	1500	1500		
L5	1	1500		1500	
L6	1	1500			1500
L7	1	1500	1500		
L8	1	1500		1500	
L9	1	1500			1500
L10	1	1500	1500		
TOTAL			6000	4500	4500

3.2.1 LOAD SUMMARY

SINCE POWER FACTOR IS 1;

RED PHASE = 6000VA

$$\text{CURRENT DEMAND} = \frac{6000}{230} = 26.1\text{A}$$

YELLOW PHASE = 4500VA

$$\text{CURRENT DEMAND} = \frac{4500}{230} = 19.6\text{A}$$

BLUE PHASE = 4500VA

$$\text{CURRENT DEMAND} = \frac{4500}{230} = 19.6\text{A}$$

TOTAL LOAD = (6000 + 4500 + 4500) = 15000VA

$$\text{TOTAL CURRENT (I)} = \frac{15000}{\sqrt{3} \times 415} = 20.9\text{A}$$

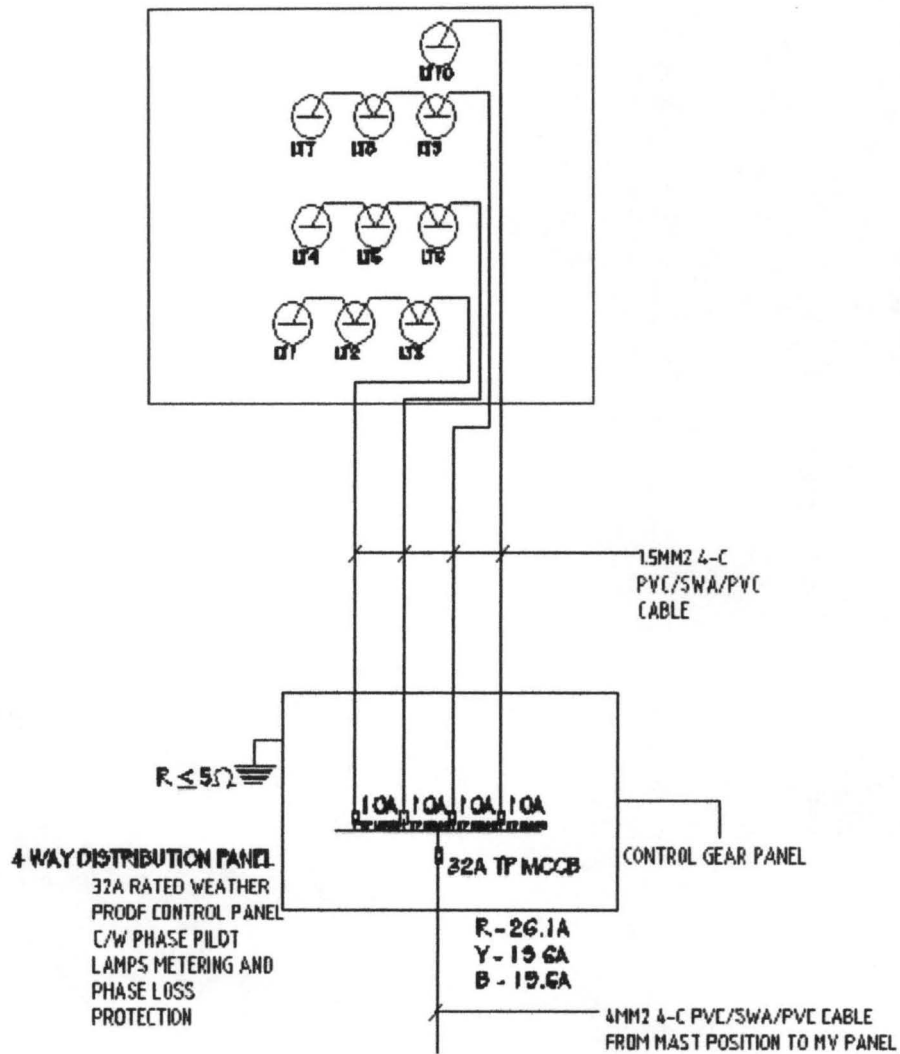

Fig.3.5 schematic representation of MV panel

The above control gear panel calculation and design is same for 1st, 3rd, 4th, 6th pitch lights.

Table 3.3: load calculation and balancing for the MV panel of the 2nd and 5th pitch lights.

CIRCUIT	No. of lamps	TOTAL LOAD (W)	LOAD ESTIMATE (watt)		
			RED PHASE	YELLOW PHASE	BLUE PHASE
L1	1	1500	1500		
L2	1	1500		1500	
L3	1	1500			1500
L4	1	1500	1500		
TOTAL			3000	1500	1500

3.2.2 LOAD SUMMARY

Since power factor for the lamp is 1;

RED PHASE = 3000VA

$$\text{CURRENT DEMAND} = \frac{3000}{230} = 13\text{A}$$

YELLOW PHASE = 1500VA

$$\text{CURRENT DEMAND} = \frac{1500}{230} = 6.5\text{A}$$

BLUE PHASE = 1500VA

$$\text{CURRENT DEMAND} = \frac{1500}{230} = 6.5\text{A}$$

TOTAL LOAD = (3000 + 1500 + 1500) = 6000VA

$$\text{TOTAL CURRENT (I)} = \frac{6000}{\sqrt{3} \times 415}$$

$$= 8.3\text{A}$$

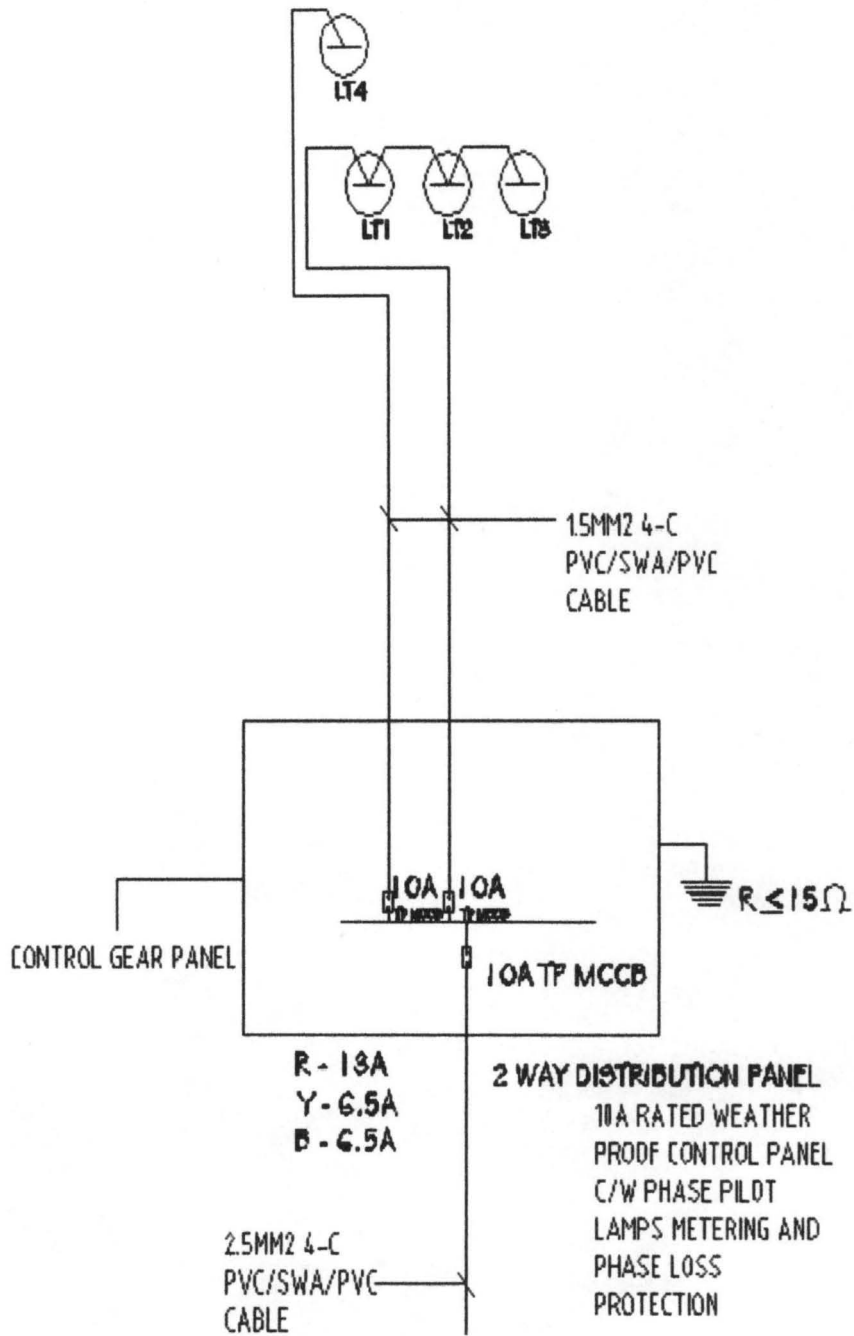

Fig.3.6 schematic representation of MV panel for the second and fifth pitch lights.

The control gear panel feeds 2nd and 5th pitch lights.

Table 3.4: load calculation and balancing for the main distribution panel

Control panel	CURRENT ESTIMATE (W)		
	RED PHASE	YELLOW PHASE	BLUE PHASE
1 st	6000	4500	4500
2 nd &5 th	3000	1500	1500
3 rd	6000	4500	4500
4 th	6000	4500	4500
6 th	6000	4500	4500
TOTAL	27000	19500	19500

TOTAL LOAD DEMAND CONSIDERING ALL TEN POLES

RED PHASE = 24000VA

$$\text{CURRENT DEMAND} = \frac{27000}{\sqrt{3} \times 415} = 37.6\text{A}$$

BLUE PHASE = 19500VA

$$\text{CURRENT DEMAND} = \frac{19500}{\sqrt{3} \times 415} = 27.1\text{A}$$

YELLOW PHASE = 19500VA

$$\text{CURRENT DEMAND} = \frac{19500}{\sqrt{3} \times 415} = 27.1\text{A}$$

TOTAL LOAD = (27000 + 19500 + 19500) = 66000VA

$$\begin{aligned} \text{TOTAL CURRENT (I)} &= \frac{66000}{\sqrt{3} \times 415} \\ &= 91.8\text{A} \end{aligned}$$

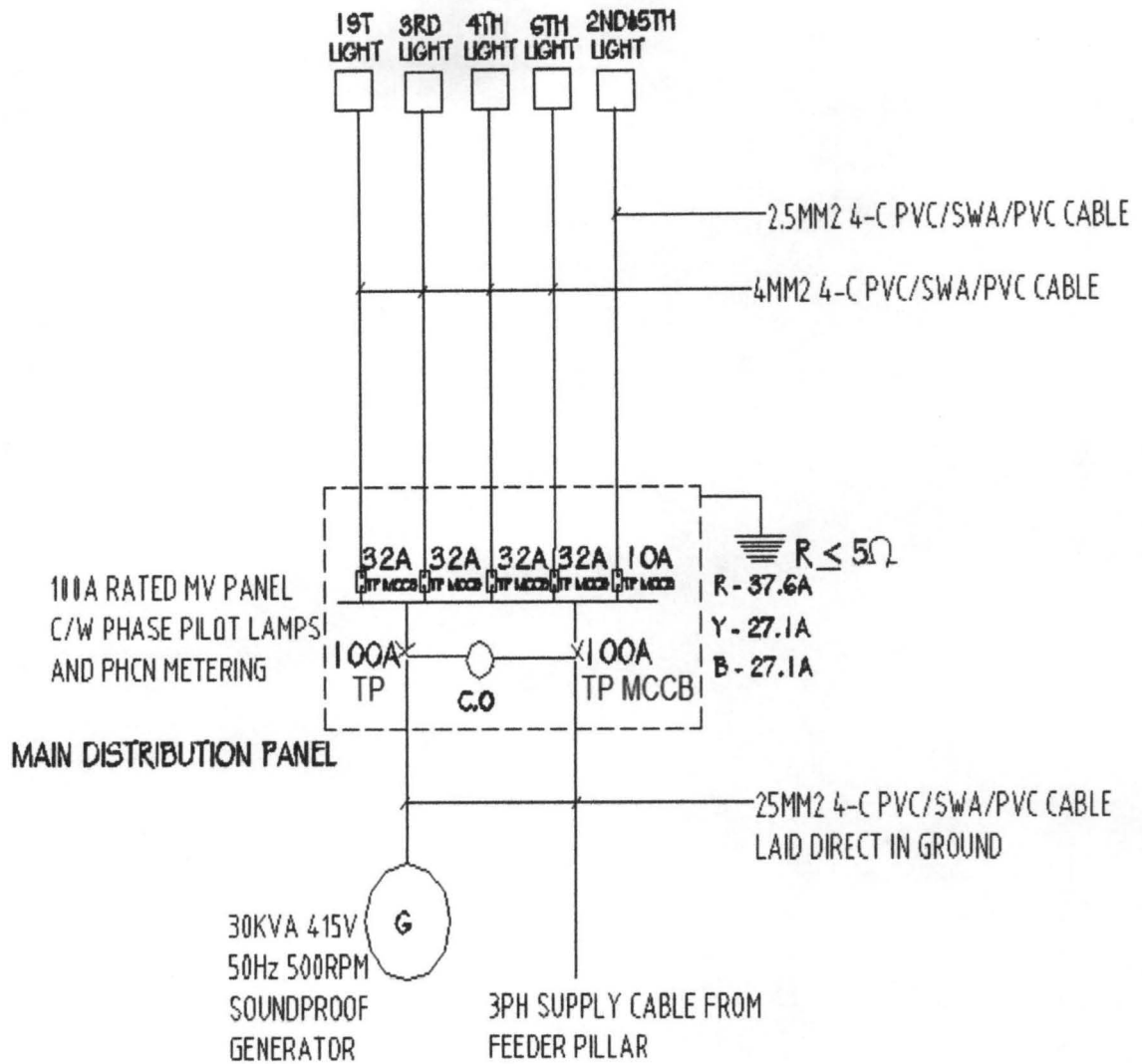

Fig.3.7 schematic representation of main distribution (MV) panel

3.3 STANDBY EQUIPMENT

Standby power equipment's are usually fuel driven generators installed in the premises to provide power when there is failure in the public main supply. Fuel driven generators range from the small portable petrol type with output at between 0.5KVA single phases (240V) to the large types, which are operated on diesel fuel with output from 5KVA to over 1500KVA, at 415V TPN.

For the particular application of this project work, from the load summary table, the rating of the generator required can be obtained by calculation as shown below.

Total Load/Phase	Red Phase	37.6A
	Yellow Phase	27.1A
	Blue phase	27.1A
	Total	91.8A

$$\text{Total KVA} = \frac{91.8 \times 230}{1000} = 21.11\text{KVA}$$

Therefore, the standard rating of the generator that will be able to carry the above load will be a 30KVA 3phases soundproof generator.

3.4 CABLING

The type of cables to be used for a particular installation application is based on the current carrying capacities of the various cables, specified by IEE regulation and also on general filed practice.

From the load calculation, the total load demand for the football field is approximately 92A. Therefore a $25\text{mm}^2 \times 4$ core PVC/SWA/PVC cable should be used as the incomer to the premises.

From the MV panel to pitch lights: 1, 3, 4, 6. There is a load demand of approximately 21A therefore a $4\text{mm}^2 \times 4$ -core PVC/SWA/PVC cables should be used. For pitch lights: 2 and 5 with load demands of approximately 8A, a $2.5\text{mm}^2 \times 4$ -core PVC/SWA/PVC cable should be used. For MV panels: 1, 2, 3, 4 and 6, a 1.5mm^2 3-c PVC/SWA/PVC cable should be used between the load(lamp) and the MV panels.

3.5 CALCULATION OF THE MAXIMUM RESISTANCE OF THE EARTH ELECTRODE

For the main distribution panel;

The highest distribution panel MCCB = 100A

Expected Excess current = $1.5 \times 100 = 150$

Phase voltage = 230V

Earth Electrode Resistance = $R = 230/150 = 2\Omega$

For the 1st MV panel;

The highest distribution panel MCCB = 32A

Expected Excess current = $1.5 \times 32 = 48$

Phase voltage = 230V

Earth Electrode Resistance = $R = 230/48 = 5\Omega$

For the 2nd MV panel;

The highest distribution panel MCCB = 10A

Expected Excess current = $1.5 \times 10 = 15$

Phase voltage = 230V

Earth Electrode Resistance = $R = 230/15 = 15\Omega$

CHAPTER FOUR

4.0 DESIGN IMPLEMENTATION AND COSTING

4.1 LIGHTING

Any lamp could have been specified in this project work but for reasons of longer life (up to 10,000 hours) reliability, durability etc. Philip's 1500T3 Q/CL DE halogen lamp was specified. They have far greater lighting effect than other lamps with the same wattage.

Table 4.1 Summary of Result

Pitch Light	Illuminance (lux)	number of lamp
1 st	1.25	10
2 nd	2.5	2
3 rd	1.25	10
4 th	1.25	10
5 th	2.5	2
6 th	1.25	10
Total	10	44

Table 4.2 cost table for lamp used

DESCRIPTION	RATING (WATTS)	QUANTIT Y	UNIT COST (₦)	TOTAL COST (₦)
PHILIP1500T3Q/CLDE	1500	44	4500	198000

4.2 POWER

Table 4.3 costing for power

S/ N	DESCRIPTION	QUAN TITY	UNIT COST(₦)	TOTAL COST(₦)
1	25mm ² × 4-core PVC/SWA/PVC	50	1900	95000
2	4mm ² × 4-core PVC/SWA/PVC	360	500	180000
3	2.5mm ² × 4-core PVC/SWA/PVC	65	600	39000
4	1.5mm ² 4-c PVC/SWA/PVC	80	500	40000
5	Metallic poles	6	43000	258000
6	100A MAIN DISTRIBUTION PANEL	1	30000	30000
7	4-WAY MV PANEL	4	20000	80000
8	2-WAY 10A MV PANEL	1	15000	15000
9	30KVA 3PHASE SOUNDPRO OF GENERATOR	1	1700000	1700000
TOTAL				2437000

CHAPTER FIVE

5.1 SIGNIFICANCE

The aim of this project is to design complete electric power network to a football field provided with halogen lamp to produce illumination level of 10lux at 1meter interval.

The significance of this design includes:

- I. Meeting up with demands and effectiveness.
- II. Protection of life and properties (equipment).
- III. Catering for some basic needs to meet up with the prevailing standards and style in the light of technological advancement.
- IV. To be able to trace faults and draw up maintenance schedule.

5.2 LIMITATIONS

Since this project work is hypothetical, even though feasible as football field. The major limitation is that it is not being implemented. Also, as a result of its hypothetical nature, the cost of design was not taken into consideration in arriving at the total project cost.

Another limitation is that due to fluctuations in the market prices, design and implementation cost may vary.

5.3 CONCLUSION

The objective of this project was to design an electric power network to a football field provided with halogen lamp to produce illumination level of 10lux at 1metre interval. As seen from **Table 4.1** the total illuminance produced by all the luminaire stands is 10lux at the middle of the field, which should have the minimum illumination. On the other hand, other points on the football field are of higher illuminance. The design incorporates an emergency power supply (Generator) in case of outage.

Table 5.1 Overall costs of the entire materials that will be used to implement the design.

S/N	DESCRIPTION	TOTAL COST (₦)
1	Lamps	198000
2	Power design	2437000
TOTAL		2635000

5.4 SUGGESTION FOR FURTHER WORK.

The following suggestions are made for further work in respect of this project.

- I. To use lamps like metal halide, LED floodlights so as to reduce both cost and power consumption.
- II. To make the field completely free from non-renewable fuel dependence i.e. for the entire power and lighting design.

REFERENCES

- [1] Oria Usifo "Electrical Networks Design and installation in buildings" 2nd Edition, Fredorus LTD Publishing Division, Benin City Nigeria 2004 pp. 20,126-129.
- [2] I.E.E "Regulations for the Electrical Equipment of buildings" 17th Edition, I.E.E Savoy Place, London 2008 pp. 98, 40-67.
- [3] Amit Chatomba "Illumination and Noise Survey in Mines (National Institute of Technology, Rourkela)" 2010 pp. 5-9
- [4] Wikipedia. "Halogen lamp." [http://en.wikipedia.org/wiki/Floodlights\(sport\)](http://en.wikipedia.org/wiki/Floodlights(sport))
- [5] M. Ugur UNVER, Nazim IMAL "Lighting Design for a football field" 1999 pp. 454-457
- [6] J.O Paddock "Electrical Installation Technology and Practices" 8th Edition, 1997 pp. 245-250.
- [7] A.O Akintante and J.M Hyde, Electrical Installation, Low Cost Edition, 1987 pp. 128
- [8] Barrie Rigby "Design of Electrical Services for Buildings" 4th Edition, Spon Press, New york 2005 pp.131
- [9] Nigerchin "wiring and cable catalogue" 2008.
- [10] Wikipedia. "Transformer." <http://en.wikipedia.org/wiki/Transformers>.
- [11] L.S. Chan. "lumen method calculations." <http://personal.cityu.edu.hk/~bsapplec/lumen.htm>
- [12] Abacus. "Designing for sport." <http://www.lighting4sport.com/>
- [13] Philips, Catalogue 2004-2005 pp. 2-68.
- [14] The New Encyclopaedia Britannica Micropaedia Ready Reference, vol 4, 15th Edition, 1998.
- [15] B.L Theraja and A.K Theraja, Electrical Technology, 1999 pp. 1527-1559.