

**DESIGN AND CONSTRUCTION OF
INTERLLIGENT
REFRIGERATOR ALARM SYSTEM**

BY

RAKIYA ABDULLAHI

MATRICULATION NUMBER:

2005/23167EE

**ELECTRICAL AND COMPUTER ENGINEERING
DEPARTMENT**

**SCHOOL OF ENGINEERING AND
ENGINEERING
TECHNOLOGY**

**FEDERAL UNIVERSITY OF TECHNOLOGY,
MINNA.**

NOVEMBER, 2010

**DESIGN AND CONSTRUCTION OF
INTELLIGENT REFRIGERATOR ALARM
SYSTEM.**

BY

**RAKIYA ABDULLAHI
MATRICULATION NUMBER:
2005/23167EE**

**A THESIS SUBMITTED TO THE DEPARTMENT OF
ELECTRICAL AND
COMPUTER ENGINEERING, SCHOOL OF
ENGINEERING AND
ENGINEERING TECHNOLOGY, FEDERAL UNIVERSITY
OF
TECHNOLOGY, MINNA, IN SPARTIAL FULFILMENT OF
THE
REQUIREMENTS OF THE AWARD OF THE BACHELOR
OF ENGINEERING (B.ENG) DEGREE IN ELECTRICAL
AND COMPUTER ENGINEERING**

NOVEMBER, 2010.

DEDICATION

This entire work is dedicated to God Almighty, throughout our lives through his messenger, prophet Muhammed (P.B.U.H), My parents whose prayers, support, encouragement, wisdom and faith in me are all This entire work is dedicated to God almighty, whose mercy we have been enjoying being felt and in all, this work is dedicated to whole my family and friends.

DECLARATION

I, **Rakiya Abdullahi**, hereby declare that this project work was done by me. It has not been carried out before in any organization for any award other than the Federal University of Technology, Minna Niger State.

Rakiya Abdullah

(Name of student)

R. Abdullahi 18/01/2011

(Signature)

Mr. Steven Oyewobi

(Name of Supervisor)

~~Steven Oyewobi~~ 18/01/2011

(Signature)

Engr. A. Raji

(Name of H.O.D)

A. Raji (Jan 27, 2011)

(Signature and Date)

Dr. G. I. Idris

(Name of External Examiner)

G. I. Idris 25/1/11

(Signature and Date)

CERTIFICATE

This project titled "design and construction of intelligent refrigerator alarm system" carried out by **RAKIYA ABDULLAHI** with Matric Number 2005/23169EE meets the standard of the award of Bachelor of Engineering (B-Engr.) DEGREE in the department of Electrical and computer Engineering school of Engineering and Engineering Technology, Federal University of Technology, Minna Niger State.

 18/7/2011
.....

Mr. Steven Oyewobi
Supervisor

.....
Date

.....

Engr. A. G. Raji
Head of department

.....
Date

.....

External Supervisor

.....
Date

ABSTRACT

This project is based on design and construction of a refrigerator alarm system. It beeps if the fridge door is left open for too long or hasn't closed properly, to stop food from spoiling. There are lots other uses as well. A refrigerator or freezer door that is left open or ajar may cause the food contents to spoil. In some cases, the internal temperature of the fridge or freezer will be maintained if the refrigerator system can cope with the open door.

TABLE OF CONTENT

1. INTRODUCTION	1
1.0.1 Motivation	1
1.1 Aims and Objectives	2
1.2 Scope	2
1.3 Methodology	2
2.0 History	3
2.1 Theoretical Background	6
2.2 The power Supply Unit.....	7
2.2.1 Transformer	8
2.2.2 Rectifier	8
2.2.3 Filtering Circuit	10
2.2.4 7805 Voltage	10
2.3 38051 Microcontroller	10
2.4 Led	11
2.5 Register	12
2.6 LDR	12
2.7 Buzzer	13
2.8. Transistor	13
2.8.1 Types of Transistor	13
2.8.2 Functional Model of an NPN Transistor	14
3.0 Design and Construction	14
3.1 Design of power supply line	16
3.2 Block Diagram of a Typical power supply	17
3.3 Circuit Diagram of Power Supply Unit	17
3.3 Design of microcontroller Unit	22
3.3.1 Features of AT89C52 Microcontroller	23
3.3.2 Programming the AT89C52 Microcontroller	23
3.4 Design of alarm Unit	25
3.5 Over-all Outlay of Circuit	26
4.1 Introduction	27

CHAPTER ONE

1.0 INTRODUCTION

In recent times, advancement in world of technology has led to the production of several device for preservation. Among these are: Fridge, Microwaves Oven etc. Most homes suffer the spoilage of perishable foods.

Refrigeration is the process of lowering the temperature and marinating it in a given space for the purpose of chilling foods, preserving certain substances or providing an atmosphere conducive to bodily comfort. Storing perishable foods, furs pharmaceuticals, or other items under refrigerator is commonly known as cold storage, such refrigeration checks both bacterial growth and adverse chemical reaction that occur in the normal atmosphere.

Typically, refrigerators and freezers are in constant use in the summer months and so it is important to ensure that the door is not open for any time longer than necessary, otherwise the fridge or freezer will not be able to keep the contents cool. While it will cost more money to needlessly run the fridge's compressor in a futile effort to keep the contents cool.

1.1 MOTIVATION

Preservation is a major problem the farmers and the consumers of farm products face. In the past, farmers are used to preserving their products with the help of sun light other local method like drying smoking, salting etc These methods have really helped the farmers and consumers in preserving the farm products and food stuffs alike.

Even the most diligent fridge user may some times leave the door of the fridge or freezer open without realizing it. And tilting the fridge or freezer slightly backward so that the door will fall shut is not completely fool proof as there may be an obstruction inside the door. The obstruction could be because an item inside the compartment has moved or fallen over or because the compartment is too full. This is where the fridge alarm is used.

1.1 AIMS AND OBJECTIVES

- To prevent food from spoiling
- To alert the owner if refrigerator is open
- To improve the life span of the refrigerator

1.2 SCOPE

This project monitors the opening and closing of a fridge door. The alarm will only beep after 40 seconds, if the user or owner of the fridge left door open after use

1.3 METHODOLOGY

This project is based on the principle of operation of a photo resistor. A photo resistor is a device the resistance of which varies with the change in the intensity of light falling on it. There are several types available. But a light dependent resistor (LDR) will be used for this project

When a fridge of any kind is open, and light is on. The light is used to reduce the resistance of LDR which in turn reduces the voltage applied across its terminal. The resultant voltage is led to one of the input pins of a micro controller IC which will wait for a period of 40 seconds after which it sounds an alarm if the door placed inside the fridge is not yet closed. The whole of this is based on the assumption that the device will be placed inside the fridge and that all the components can survive within the operating temperature of the fridge.

A secondary sensor known as the contact sensor is produced for the micro controller if the device is to be placed outside the fridge due to non survival of the component.

CHAPTER TWO

2.0 HISTORY

Hohn Gorrie (1803-1855), American physician, the inventor of cold-air refrigerator, Born in Charleston, South Carolina, Gorrie graduated from the college of physicians and surgeons in New York City in 1833 He established a medical practice at Apalachicola, Florida, where he also served as postmaster, city treasurer, and city councilman and then as a mayor, from 1837-1839.

Many of Gorrie's patients suffered from malaria or other disease that cause high fever. Warm hospital rooms compounded their discomfort. Gorrie thought he could lower the body temperature of hospital patients by blowing air over blocks of ice to cool their in 1844, he tested his theory by designing and building an experimental ice-making machine

The mechanical refrigerator component of the ice-making is what Gorrie is remembered for today. He based his machine on the physical principle that heat always flows from a warmer gas or liquid to a cooler one. His machine compressed some a gas, causing it to heat, and then sent the gas further; lowering temperature even more than the cool gas in the coils cooled the nearby air. Gorrie's application of compressed and decompressed gas as a coolant in radiant coils remains the common method for cooling air in modern refrigeration systems.

In 1845, Gorrie left medical practice to improve on his process of mechanical refrigeration. He introduced an ice-making machine in 1848. Two years later he received a patent for the device- the first ever issued for a refrigeration machines in many southern cities, but he failed to raise the financial support needed to build a commercial ice plant

The use of natural or manufactured ice for refrigeration was widespread until shortly before World War I, when machines or electric refrigerators became available. Ice owes its effectiveness as a cooling agent to the fact that it has a constant fusion temperature of 0°C (32°F). In other to melt, ice must absord heat amounting to 333.1kJ/kg (143.3 Btu/lb) melting ice in the presence of a dissolving salt lowers its melting point by several

degrees foodstuffs maintained at this temperature or slightly above have an increased storage life. Solid carbon dioxide, known as dry ice, is used also as a refrigerant. Having no liquid phase at normal atmospheric pressure, it sublimates directly from the solid to the vapor phase at a temperature of 78.5°C (-109.3°F). Dry ice is effective for maintaining products at low temperature during the period of sublimation.

In mechanical refrigeration, constant cooling is achieved by the circulation of a refrigerant in a closed system, in which it evaporates to a gas and then condenses back again to a liquid in a continuous cycle. If no leakage occurs, the refrigerant lasts indefinitely throughout the entire life of the system. The systems used are the compression system, used in domestic units for large cold storage applications and for most air-conditioning units, and the absorption system, now employed largely for heat-operation air-conditioning units but formerly also used for heat-operation domestic units.

For every refrigerant there is a specific boiling or vaporizing temperature associated with each pressure, so that it is only necessary to control the pressure in the evaporation to obtain a desired temperature. A similar pressure-temperature relationship holds in the condenser. One of the most widely used refrigerants for many years has been dichlorodifluoromethane, known popularly as refrigerant 12. This synthetic chlorocarbon (CFC) when used as a refrigerant would, for example, evaporize at -6.7°C (20°F) in its evaporator under a pressure of 246.2 kpa (35.7 psi) and would condense at 37.8°C (100°F) in the condenser. The resulting condensed liquid would then enter the expansion valve to drop to evaporator pressure and repeat the cycle of absorbing heat at low temperature and low pressure and dissipating heat at the much higher condenser pressure and temperature. In small domestic refrigerators used for food storage, the condenser heat is dissipated into the kitchen or other room housing the refrigerator. With air-conditioning units the condenser heat must be dissipated out of doors directly into cooling water. In a domestic refrigerator system the evaporator, called the freezer, is always placed in an insulated space. Constituting the whole refrigerator cabinet the compressor is usually oversized, so that if it ran continuously it would produce progressively lower temperature. In order to maintain the interior of the box within the desired temperature range, the motor driving the compressor is controlled by a thermostatic switch.

A frozen food stuff refrigerator resembles the household refrigerator except that its compressor and motor must be sufficient size to handle the larger gas volume of the refrigerant at its lower evaporator pressure. For example, to maintain a temperature of 23.3°C (-10°F) an evaporation pressure of 132.3kpa (19.2 psi) is required with refrigerant 12

A few household units, called gas refrigerators, operate on absorption principle. In such gas refrigerator and the ammonia is driven off as a vapor. Which passes in to a condenser change to a liquid state in the condenser, the ammonia flows to the evaporation as in the compression system instead of the gas being inducted in to a compressor on exit from the evaporator, the ammonia gas is reabsorbed in the partially cooled, weak solution returning from the generator, to form the strong ammonia solution. This process of reabsorption occurs in a container called the absorber, from which the enriched liquid flows back to the generator to complete the cycle.

Increasing use of absorption refrigeration occurs in refrigeration units for comfort space cooling, for which purpose refrigerant temperatures of 45° to 50°F (7.2° to 10°C) are suitable. In this temperature range, water can be used as a refrigerator with an aqueous salt solution, usually lithium bromide, as the absorbent material. The very cold boiling water from the evaporator is absorbed in concentrated salt solution. This solution is then pumped in to the generator, where at elevated temperature, the surplus water is boiled off to increase the salt concentration of the solution, this solution, after cooling re-circulates back to the absorber to complete the cycle. The system operates at high vacuum at an evaporator (32°F). In other melt, ice must absorb heat amounting to 333.1kJ/kg (143.3Btu/lb) melting ice in the presence of a dissolving salt lowers its melting point by several degrees foodstuffs maintained at this temperature or slightly above have an increased storage life solid carbon dioxide, known as dry ice, is used also as a refrigerant. Having no liquid phase at normal atmospheric pressure, it sublimates directly from the period of the solid vapor phase at a temperature of 78.5°C (-109.3°F) Dry ice effective for maintaining products at low temperature during the period of sublimation.

In mechanical refrigeration, constant cooling is achieved by the circulation of a refrigerant in a close system, in which it evaporates to a gas and then condenses back again to a liquid in a continuous cycle. If no leakage occurs, the refrigerant lasts indefinitely throughout the entire life of the system. All that is required to maintain cooling is a constant supply of energy or power and a method of dissipating waste heat. The two main types of mechanical refrigeration system used are the compression system, used in domestic units for large cold storage applications and for most air-conditioning; and the absorption system, now employed largely for heat-operated air-conditioning units but formerly also for heat operated domestic units

For every refrigerant there is a specific boiling, or vaporizing, temperature associated with each pressure, so that it is only necessary to control the pressure in the evaporator to obtain a desire temperature. A similar pressure-temperature relationship holds in the condenser. One of the most widely used refrigerants for many years has been dichlorodifluoromethane, known popularly as refrigerant 12 this synthetic chlorofluorocarbon (CFC) when used as a refrigerant would, for example, vaporize 6.7°C (20°F) in the condenser. The resulting condenser liquid would then enter the expansion valve to drop to evaporate pressure and repeat the cycle of absorbing heat at low temperature. In small domestic refrigerators used for food storage, the condenser heat is dissipated in to the kitchen or other room housing the refrigerator. With air-conditioning units the condenser heat must be dissipated out of doors directly in to cooling water.

Pressure of about 1.0 kpa (0.145 psi); the generator and condenser operate at about 10.0 kpa (1.45 psi). the units are usually direct-fired or use steam generated in a boiler

2.1 THEORITICAL BACKGROUND

This project is designed to achieve an alarm circuit positioned within said alarm housing and including a trigger circuit, a timer circuit responsive to said trigger circuit, a voice generating message circuit responsive to said trigger circuit, a buzzer responsive to said timer circuit

The system design could be categorized in to the following.

1. Power supply unit
2. Sensing unit
3. Microcontroller unit
4. Alarm unit

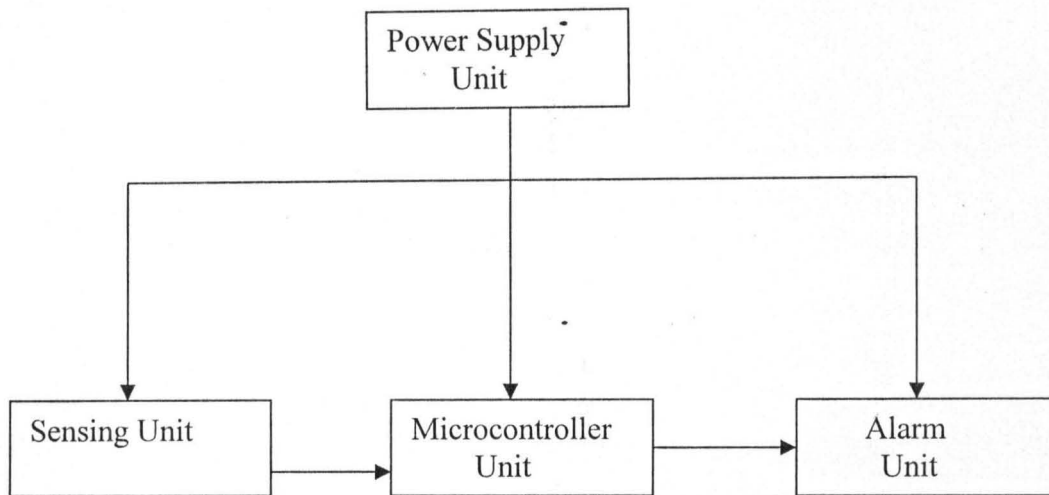

Fig 2.1 showing the block diagram of the circuit

2.2 THE POWER SUPPLY UNIT

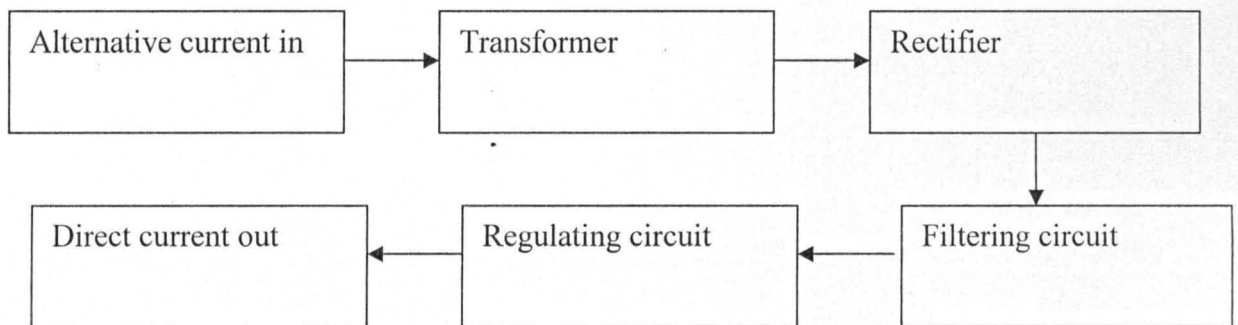

Fig 2.2 showing the block diagram of the power supply unit

2.2.1 TRANSFORMER

A transformer is a device that transfers electrical energy from one circuit to another through inductively coupled conductors—the transformer's coil. A varying current in the first or primary winding creates a varying magnetic flux in the transformer's core, and thus a varying magnetic field through the secondary winding his varying magnetic field induces a varying electromotive force (EMF) or "voltage" in the secondary winding. This effect is called mutual induction.

The designs makes use of 240v-24v transformer. This step 240v alternating current to 24v alternating current.

If a load is connected to the secondary circuit an electric current will flow in secondary winding and electric energy will be transferred from primary circuit through the transformer to the load. In an ideal transformer, the induced voltage in the secondary winding (V_s) is in proportion to the primary voltage (V_p), and is given by the ratio of the number of turns in the secondary (N_s) to the number of turns in the primary (N_p) as follows:

$$\frac{V^s}{V^p} = \frac{N^s}{N^p}$$

By appropriate selection of the ratio of turns, a transformer thus allows an alternating current (AC) voltage to be "stepped up" by making N_s greater than N_p or "stepped down" by making N_s less than N_p

2.2.2 RECTIFIER

Diodes allow electricity to flow in one direction. The arrow of the circuit symbol shows the direction in which the current can flow. Diodes are the electrical version of a valve and early diodes were actually called valves.

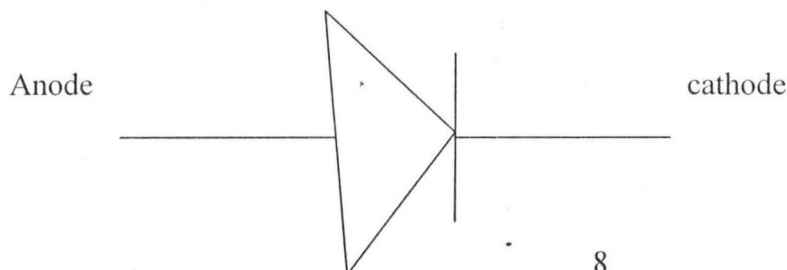

Rectifier diodes are used in power supplies to convert alternating current (AC) to direct current (DC), a process called rectification. They are also used elsewhere in circuits where a large current must pass through the diode.

All rectifiers are made from silicon and therefore have a forward VOLTAGE DROP OF 0.7V. The table shows maximum current and maximum reverse voltage for some popular rectifier diodes. The 1N4001 is suitable for most low voltage circuits with a current of less than 1A.

Bridge Rectifier

This design makes use of four diodes (D1, D2, D3 and D4) to achieve a rectified DC output. During the positive half cycle diodes (D1 and D3) will conduct while during positive half cycle diodes (D2 and D4) will conduct. There are several ways of connecting diodes to make a rectifier to convert AC to DC. The bridge rectifier is one of them and it is available in special packages containing the four diodes requires. Bridge rectifier rated by their maximum current and maximum reserve voltage. They have four leads or terminals: the two DC outputs are labeled + and -, the two AC inputs are labeled?

The diagram shows the operation of a bridge rectifier as it converts AC to DC. Note how alternate pairs of diodes conduct.

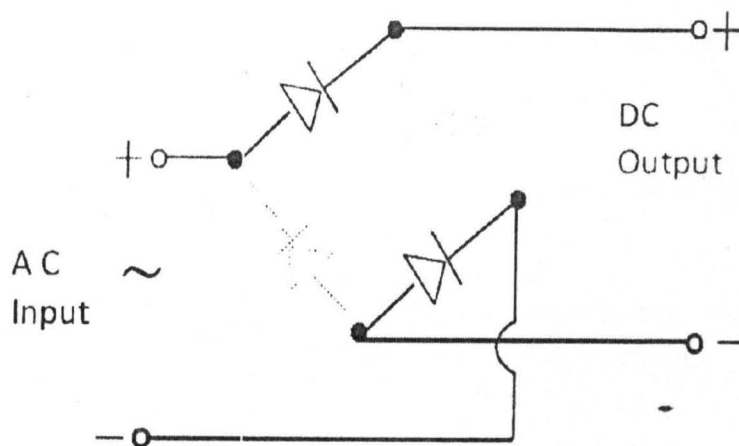

Fig. 2.4: Bridge Rectifier

2.2.3 FILTERING CIRCUIT

This is achieved with the use of 1000uf capacitor to filter unwanted DC component harmonics. Capacitors are also known to easily pass AC (changing) signals but they block DC (constant

Signals capacitors are measured in farad

There are many types of capacitors which are grouped in to two polarized and unpolarized

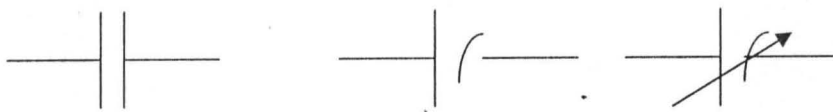

Fig 2.5 Filtering circuit

2.2.4 7805 VOLTAGE

For a power supply to give definite voltage output, it is necessary for the output voltage to remain relatively constant. Therefore a 7805 regulator is required to produce 5v regulated output three terminal voltage regulators is the most commonly used regulator types as shown below.

ICLM 7805

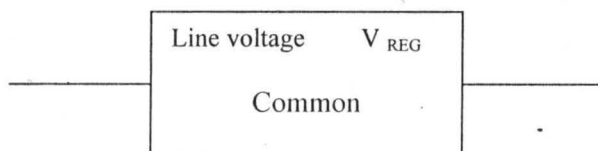

Fig 2.6: 7805 Voltage

2.3 8051 MICROCONTROLLER

A microcontroller is a single integrated circuit that execute user program normally for the purpose of controlling some device.

Micro controller are normally found in devices such as; micro ovens, automobiles keyboard CD players, cell phones, VCR, security systems, time attendance clocks, electronic toys. Etc these are devices that require some amount of computing power

which do not require so much as to justify the use of a more complex and expensive 486 or Pentium system which generally require a large amount of supporting circuitry. A microwave oven just doesn't need that much processing power.

The program for a microcontroller is normally stored in a memory IC called an EPROM or in the microcontroller IC itself

An EPROM is a special type of IC that does nothing more than store program codes or other data that are not lost when power is removed.

The 8051 is an 8-bit microcontroller originally developed by Intel in the late 1970s. It includes an instruction set of 225 operation codes (opcodes), 32 input/output lines, 2 user-controllable timers, an integrated and automatic serial port, and 128 bytes of on-chip RAM. The 8052 is similar but has 3 timers and 256 bytes of on-chip RAM.

The term 8051 will refer to any 8052-compatible microcontrollers that don't meet the specification. The Intel 8051 microcontroller was a more limited version of the 8052.

2.4 LED

LED emits light when an electric current passes through them. They must be connected the correct way round, the diagram may be labeled a or + for anode and k or - for cathode (yes, it really is k, not c, for cathode!). The cathode is the short lead and there may be a slight flat on the body of round LEDs. If you can see inside the LED the cathode is the larger electrode (but this is not an official identification method).

An LED must have a resistor connected in series to limit the current through the LED, otherwise it will burn out almost instantly.

LED voltage (usually 2V for blue and white LEDs) = LED current (e.g. 10mA = 0.01A) or 2mA = 0.002A. Make sure the LED current you choose is less than the maximum permitted.

and **convert the current to amps (A)** so the calculation will give the resistor value in ohms (Ω) To convert MA to a divide the current in MA by 1000 because 1MA=0.001 A. LEDs can be damage by heat when soldering, but the risk is small unless you are very slow. No special precautions are needed for soldering most LEDs

2.5 RESISTOR

Resistor restrict the flow of electric current, for example a resistor is placed in series with a light-emitting diode (LED) to limit the current passing through the LED.

Resistors may be connected either way round. They are not damaged by heat when soldering resistance is measured in ohms, the symbol for ohms omega Ω

1 Ω is quite small so resistor values are often given in k Ω and M Ω .

1 k Ω = 1000 Ω 1 M Ω = 1000000 Ω

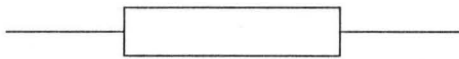

Fig 2.7: Resistor

An LDR is an input transducer (sensor) which converts brightness (light) to resistance. It is made from calcium sulphide (CDS) and the resistance decrease as the brightness of light falling on the LDR increase

A multimeter can be used to find the resistance in darkness and bright, are the typical results for a standard LDR

- Darkness maximum resistance, about 1 M Ω
- Very bright: minimum resistance, about 100 Ω

For many years the standard LDR has been the ORP12, now the NORPS12, which is about 13mm diameter. Miniature LDRs are also available and their diameter is about 5mm.

An LDR may be connected either way round and no special precautions are required when soldering.

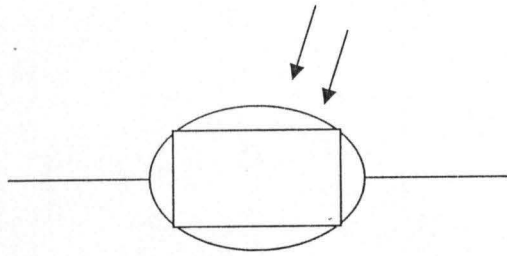

Fig 2.8 LDR

2.7 BUZZER

These devices are output transducer converting electrical energy to sound. They contain an internal oscillator to produce the sound which is set at about 400Hz for buzzer and about 3kHz for beepers.

Buzzers have voltages rating but they are only approximately, for example 6V buzzers can be used with a 9v supply. Their typical current is about 25 MA

Bleep's have wide voltage ranges, such as 3-30v, and they pass low current of about 10MA.

Buzzers and beepers must be connected the right way round, their red lead is positive (+)

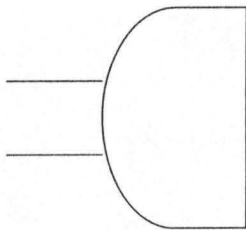

Fig 2.9 Buzzer

2.8 TRANSISTOR

Transistors serve many purposes such as amplifying and switching device/component there are various types of transistors which are PNP and NPN

2.8.1 TYPES OF TRANSISTOR

There are two types of standard transistors, NPN and PNP, with different circuit symbols. The letters refer to the layers of semiconductor material used to make the transistor most transistors used to day are NPN because this is the easier type to make from silicon.

A Darlington pair is two transistors connected together to give a very high current gain.

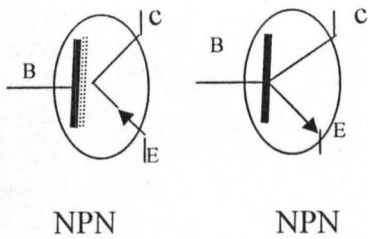

The leads are labeled **base** (B), collector (C) and emitter (E)

These terms refer to the internal operation of a transistor but they are not of much help in understanding how a transistor is used, so just treat them as labels!

2.8.2 FUNCTION MODEL OF AN NPN TRANSISTOR

The operation of a transistor is difficult to explain and understand in terms of its internal structure. It is more help to use this functional model:

- The base-emitter junction behaves like a diode.
- A base current I_B flows only when the voltage V_{BE} across the base-emitter junction is 0.7V or more.
- The small base current I_B controls the large collector current I_C .

- $I_C = h_{FE} \times I_B$ (unless the transistor is full on and saturated)
 h_{FE} is the current gain (strictly the DC current gain), a typical value for h_{FE} is 100 (it has no units because it is a ratio)
- The collector-emitter resistance R_{CE} is controlled by the base current I_B :
 - $I_B = 0$ $R_{CE} = \infty$ transistor off
 - I_B small R_{CE} reduce transistor full on ('saturated')

CHAPTER THREE

3.0 DESIGN AND CONSTRUCTION

In this chapter, the different parts of the project will be carefully analyzed. However, the block diagrams below shows the basic outlay of the work and how they are inter-related.

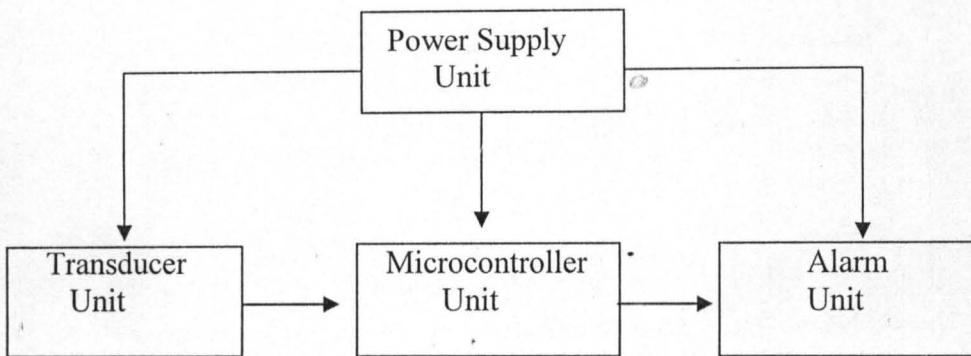

Fig 3.0 Block Diagram of Intelligent Refrigerator Alarm

Each of the blocks will then be separately analyzed for simplicity & clarity

3.1 Design of Power Supply Line

The entire electric components used require a D.C voltage supply for their operation, but our primary source of power is A.C voltage (230v). A typical D.C power supply can effectively rectify & regulate the A.C voltage to give the desired D.C voltage. The block diagram below illustrates the five basic stages of a typical supply unit.

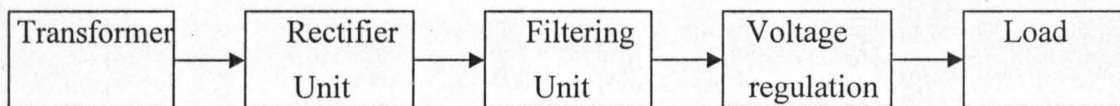

Figure 3.2 Block Diagram of a Typical Power Supply.

Therefore, the complete circuit diagram used is as shown below: -

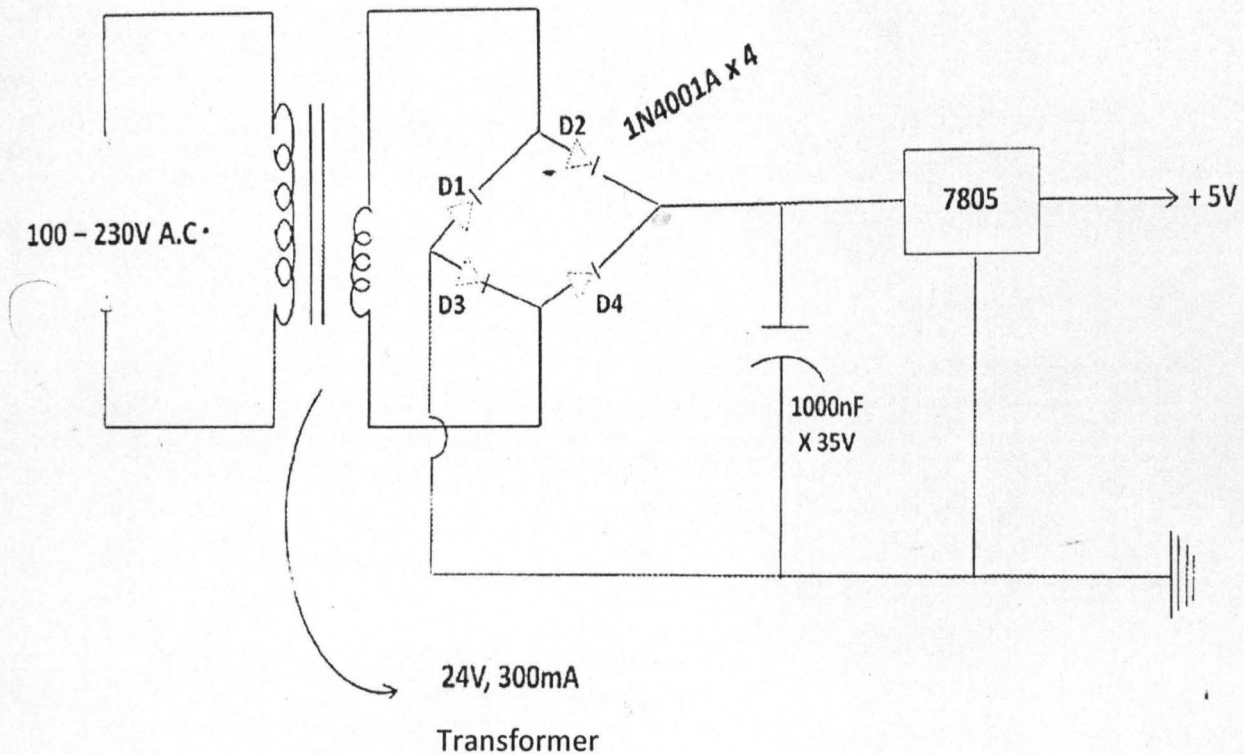

Fig 3.3 Circuit Diagram of Power Supply Unit

The transformer steps down to the main voltage of 230v to 24v A.C. It is then rectified by the full-wave bridge rectified unit (arrangement of four diodes). The output D.C voltage of the rectified unit has a lot A.V. ripples and as such requires a filter capacitor (mostly electrolyte) to be connected across. This reduces ripples to an acceptable level. Resulting voltage (DV) is calculated below;

If the load current stays constant as it will for small ripple then $I = \text{---}$

However, the frequency of the full-wave signal is double the input frequency because a full-wave output has twice as many cycles as the sine wave input is having. Therefore the output frequency of the full-wave rectifier is

$$F_{\text{out}} = 2F_{\text{in}}$$

Which implies

$$Dt = \frac{1}{2f_{in}} = \frac{1}{2 \times 50\text{Hz}} = 0.01\text{sec}$$

Thus the capacitor used to be able to start charging up in less than half a cycle.

The maximum current that can be drawn by the circuit is determined by the voltage regulator used. The 7805 voltage regulator I.C was utilized and the 7800 can output a maximum current of 1A if properly used with a heat sink. i.e. $I_{load} = 1\text{A}$ (maximum).

The value of capacitor required can be calculated by using the formula stated below:-

$$C = \frac{I_{dv}}{dt}$$

But generally, dv which is the ripple voltage is chosen to be 30% of the peak voltage, V_p which can be determined from $V_p = V_{rms} \sqrt{2}$

Where $V_{rms} = 24\text{V}$ since a transformer of 24v was used

$$\text{Thus } V_p = 24\sqrt{2} = 33.94\text{V}$$

For bridge rectifier $V_p(\text{out}) = V_p(\text{in}) - 1.4\text{v}$ is, always dropped across a diode for it to conduct and only two diodes at a time

$$V_p(\text{out}) = 33.94 - 1.4 = 32.54\text{v}$$

Therefore

$$dv = \frac{30}{100} \times 32.54 = \alpha .76\text{v}$$

$$\text{And in turn, } C = \frac{1 \times 0.01}{\alpha .76} = 0.00010246\text{F} = 1024.6\text{nf}$$

So a value of 100nf by 35v was used to reduce the ripple to the minimum.

The ripple voltage expected from the capacitor is given by

$$Dv = \frac{0.01 \times 1}{100 \times 10^{-6}} = 10.0v$$

This means that the output wave form goes from a value of 32.54v to $(32.54 - 10.0) = 22.54v$.

The input voltage to a regulator must be at least 2v above the output voltage for its proper operation and the peak value of 32.54V to 22.54V is very well accepted as their average value is above 7V as calculated below;

$$\begin{aligned} V_p - 0.5dv &= 32.54 - 0.4 \times 10.0 \\ &= 32.54 - 5.0 = 27.54V \end{aligned}$$

The output of the 7805 is always at 5v and 1A.

3.2 Design of Input Transducer Unit.

A light dependent resistor (LDR) was used to convert light energy from the fridge to electrical signal. The output of the transducer unit is connected to one of the input pins of the microcontroller (P1.0). the figure below shows the configuration of the input driver.

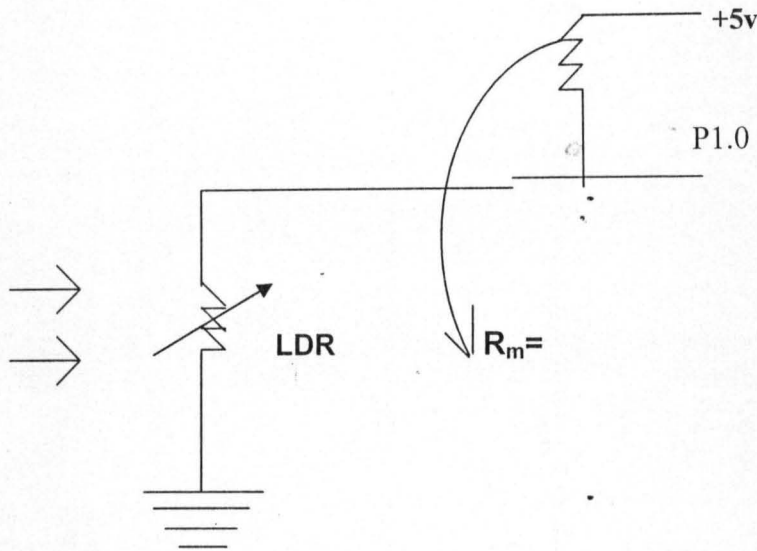

Fig 3.4 Input Transducer

The microcontroller pin is pulled by an internal pull-up resistor to Vcc. At any time, there is a voltage division between the microcontroller's internal pull up resistor, the LDR & the voltage of the LDR is applied across the pin of the microcontroller. Defaults all pin of the microcontroller are logically high. The pin is successfully triggered by taking it low by hardware. The resistance of the LDR when fully illuminated is $10n$ & $400kn$, so that the voltage applied

across the microcontroller when dark is given by
$$\frac{400}{400+100} \times 5v = 4v$$

Which is interpreted as high logic level and thus does not trigger the microcontroller

On the other hand, when fully illuminated, the voltage across the pin is given by

$$\frac{10}{10+100000} \times 5 = 0.0005$$

This is interpreted as a low logic level and thus effectively triggering the microcontroller pin.

Therefore, when anybody opens the fridge, the inner light comes on and the microcontroller is triggered.

3.3 Design of Microcontroller Unit

This is the heart of the entire project. The Atmel 89c52 was used. The figure below shows the way it was linked to other parts of the entire circuit.

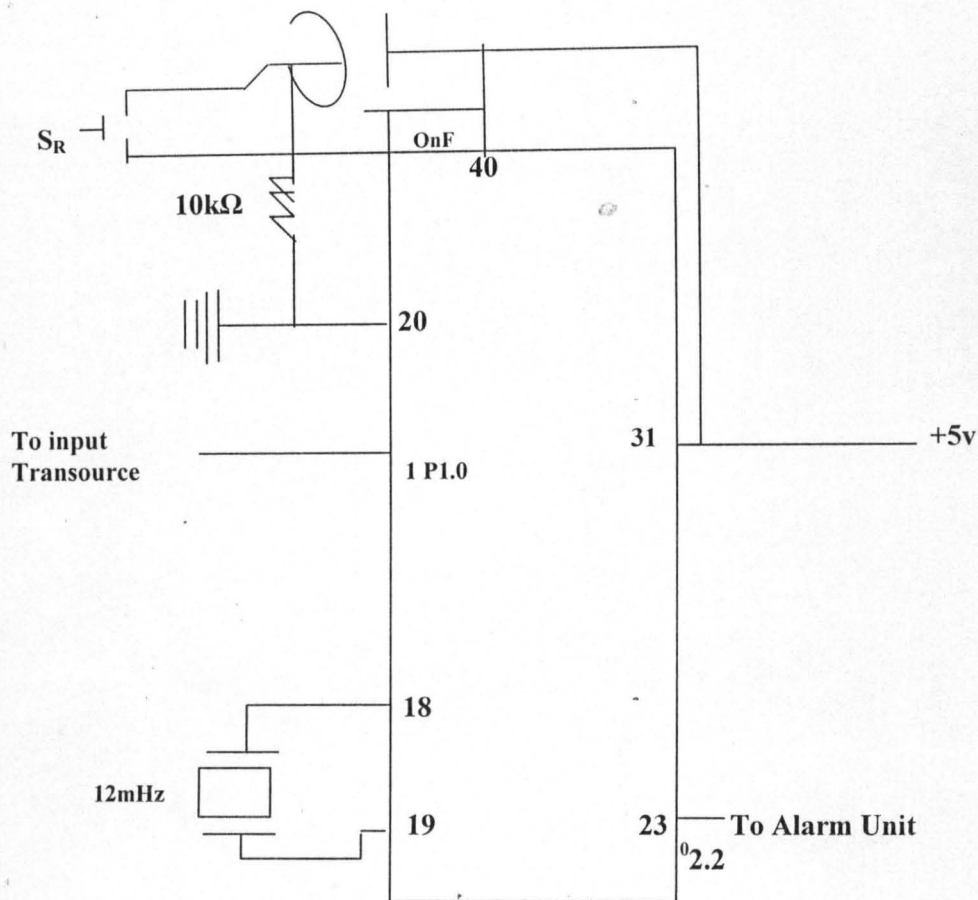

Fig 3.5 Connecting the AT89C52 Microcontroller

The crystal oscillator (12MHz) helps to synchronize the operation of the microcontrollers. The RESET used is a power-on reset with a switch to continuously reset at will. The microcontroller's reset pin (9) requires its pin to go high for at least 2ms and then low again to fully reset. The RC network allows the capacitor (IDNF) charge for a period of $t=1.1RC = 1.1 \times 10 \times 10^3 \times 10 \times 10^{-6} = 0.01s$ or 10ms during which the pin is high and afterwards low when the capacitor is fully charged. The capacitor can be discharged by the reset switch at any time.

The 89C52 microcontroller has 32 input/output parts, two of which were used for the project, Pi.0 and P2.

3.3.1 Features of the AT89C52 Microcontroller

The following are the features of the AT89C52 microcontroller that has helped in the project

- 8k bytes of reprogrammable internal flash memory
- 1000 write/erase cycles
- Fully static operation of 0Hz to 24MHz
- 256 x 8-bit internal RAM
- 32 programmable I/O lines
- Three 16-bit timers/counters
- Eight interrupt sources

3.3.2 Programming the AT89C52 Microcontroller

Assembly language was used in programming the microcontroller. The software used was the edsim51 assembly source/hex code. The flow-chart below describes the algorithm used and the source code is shown in appendix 1

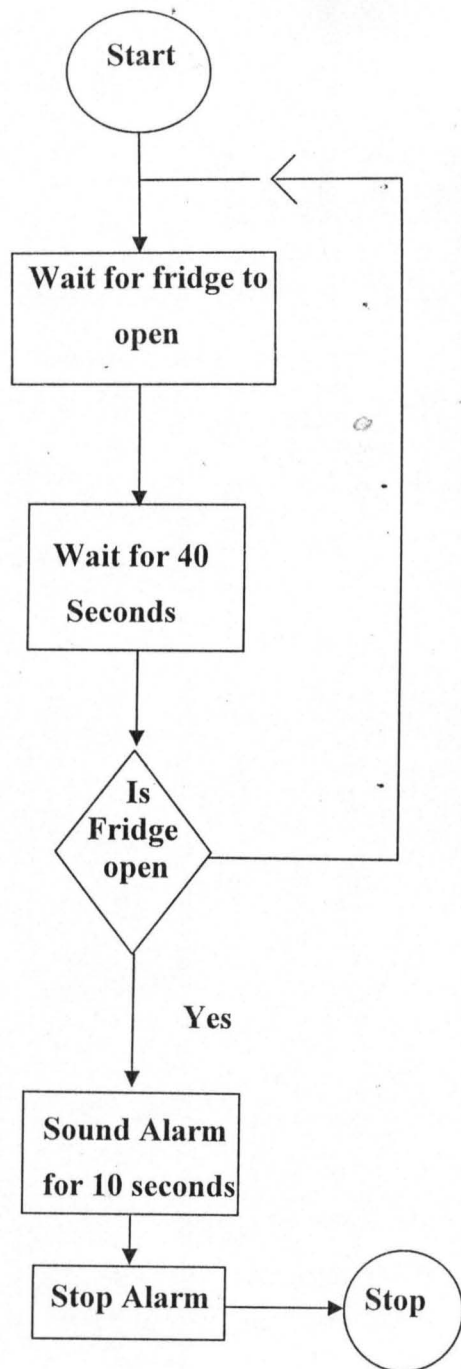

Fig 3.6 Flow Chart of Entire Program

3.4 Design of Alarm Unit

This unit comprises a buzzer switch by p2.2 of the microcontroller using a PNP transistor, A1015 as output driver. The figure below shows how the alarm unit was connected.

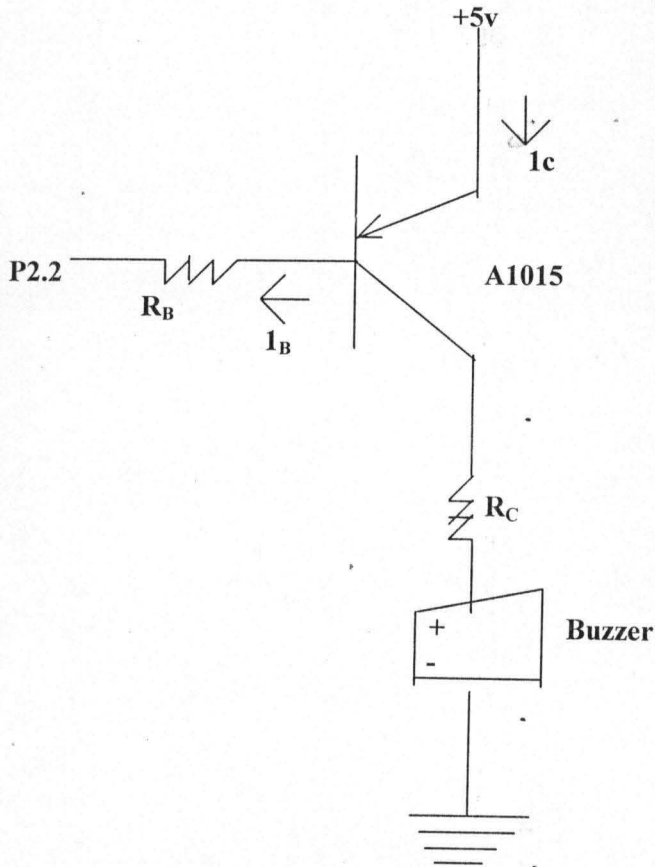

Fig 3.7 Connection of Buzzer to Transistor

The transistor goes into saturation when P2.2 goes low and the Alarm will come on. The Buzzer can sink a maximum of 30mA thus.

$$R_c = \frac{5 - 0.7}{0.03} = 143.33 \Omega$$

$$\text{Minimum base current } I_B = \frac{I_c}{HFE} = \frac{30 \times 10^{-3}}{280} = 0.000071A$$

$$= 0.107mA$$

Thus maximum base value

$$R_B = \frac{5}{0.10mA} = 46.73KA$$

To ensure saturation, a value of 1Kn was used.

3.5 Over-all Outlay of Circuit

Each of the parts discussed so far were to be together to give the circuit shown in the diagram below.

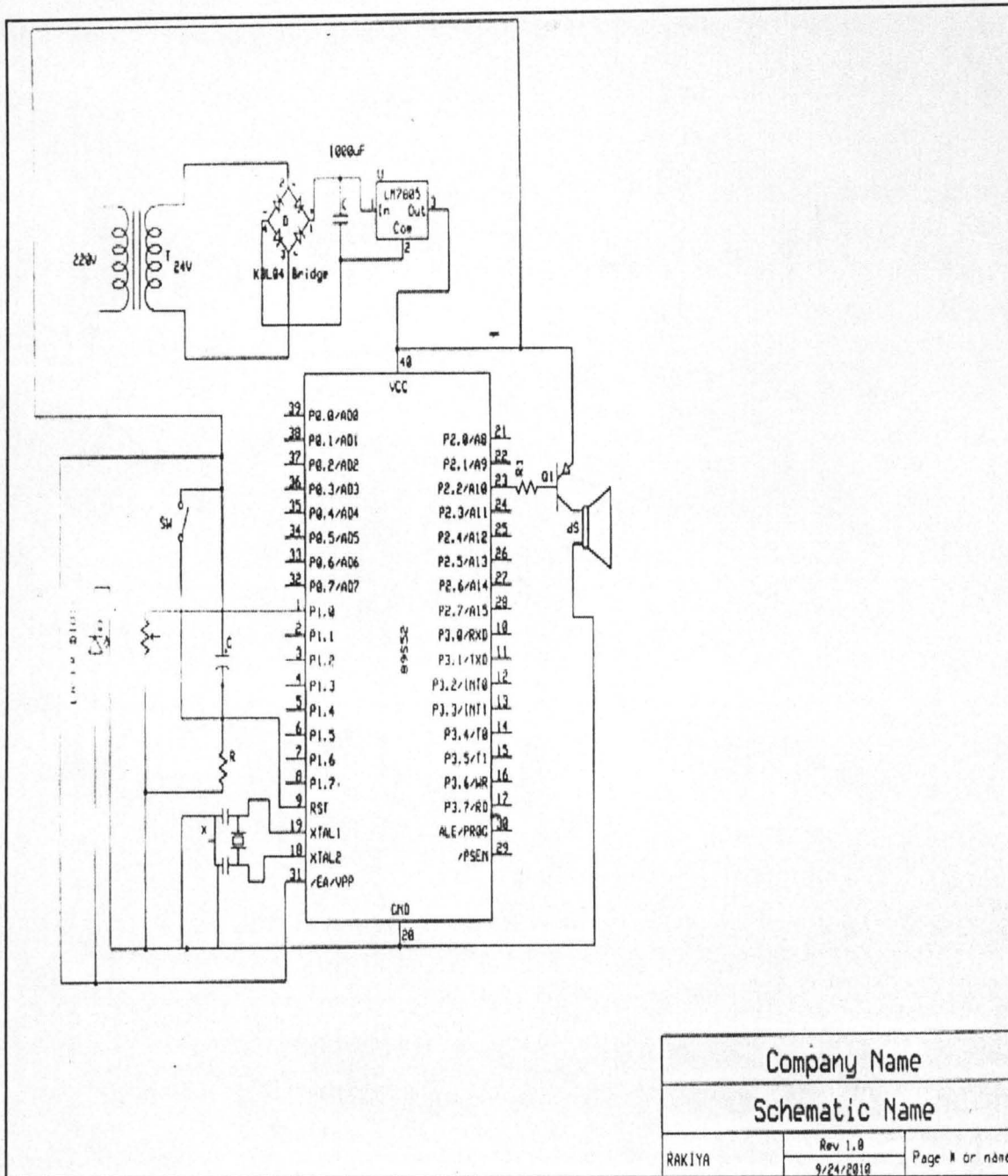

Company Name		
Schematic Name		
RAKIYA	Rev 1.0 9/24/2010	Page # or none

CHAPTER FOUR

4.1 Introduction

This chapter discusses on the actual construction producer, testing and experiment performed during the process of construction.

5s Construction

Construction of the designed work was carried out initially on a breadboard, stimulated after proper checkup to see that the device is actually working the way it should work, it was then permanently soldered on a vero board.

4.3 Casting

The casing was carried out using finely finished thin plywood with the dimension 20cm x 15cm x 10cm. During this process, many things were put into consideration such as allowance for the switch, LED indicator, buzzer etc. Perforation of the case was also carried out to allow ventilation as well as to ease heat dissipation in and cooling of the circuit components.

4.4 Testing

Different tests were carried out while construction process progressed on the vero board. This was necessary in order to obtain the outputs desired.

4.4.1 Wiring Test

The continuity of the wiring used was tested using multi-meter to check if there is any short circuit or open circuit at any point in the circuit.

4.4.2 Power Supply Test

Tests were carried out on the power supply unit. The voltages were measured after AC has been step down to 12V after rectification and regulation. The values were recorded as follows:

Tables 4.1 Power Supply Unit Test

Output Voltage	Measured value (V)	Expected Value
From transformer	11.98	12.00
From filter	11.95	11.98
From Regulator	4.98	5

4.4.3 Individual Component Test

Each of the components was subject to various tests to confirm their performance.

The exact values of the resistors and capacitors were measured using Multi-meter. Also, the polarity of the capacitors as well as the emitter, collector and base junction of the transistors was discovered.

4.5 PRECAUTIONS

The various precautions taken during the construction of this project are as follows:

- Polarities of the transistors, diodes and capacitors were correctly placed.
- All components were properly soldered on the joint to ensure firm positioning.

- IC socket was used to the microcontroller to protect it from excessive we heat that may be radiated from the circuit.
- Over flow of the lead during soldering was taken care of.
- Semiconductor components (regulators and integrated circuits) are protected from excessive heat.

CHAPTER FIVE

CONCLUSION AND RECOMMENDATION

5.1 Conclusion

A Refrigerator door alarm system finds its applications useful in homes, canteens, super markets, etc. Even the most diligent fridge user may sometimes leave the door of the fridge or freezer open without realizing it. Ant tilting the fridge or freezer backward so that the door will fall shut is not completely fool proof as there may be an obstruction inside the door. The obstruction could be because an items inside the compartment has moved or fallen over on because the compartment is too full. This is where the Fridge Alarm is useful.

5.2 Limitation

Every designed work has its limitation. This provides a way to solve the difficulties encountered during the process of construction. The limitations of this project are as follows:

- There will be continuous noise in the process of cleaning inner part of the fridge for a long time or load lots of stuffs in it.
- No circuit is incorporated with the switch which will be able to close the switch automatically when the sound is produced.

5.3 Recommendation

Research is needed on this project to probably remove the alarm and make the circuit an automatically close fridge door system.

Also a remote control can be incorporated with the switch to close the door after the alarm sounds. The use of less expensive component to reduce the cost spent on the design is recommended.

REFERENCES

- (1) ROBERT A. MEYER ENCYCLOPAEDIA OF PHYSICAL SCIENCE AND TECHNOLOGY (SECOND EDITION) ACADEMIC PRESS INC. 1992
- (2) R.J MADDOCH, DM. CALCUTT ELECTRONICS, LONGMAN PUBLISHER 1998.
- (3) WILLIAN I. FLETCHER, AN ENGINEERING APPROACH TO DIGITAL DESIGN PRENTICE-HILL, INC. 1984.
- (4) TOBEY, GRAEME, HUELSMAN OPERATIONAL AMPLIFIERS DEESIGN AND APPLICATION, MC GRAW HILL 1981.
- (5) S.J SANGWINE, ELECTRONIC COMPONENTS AND TECHNOLOGY CHAPMAN & HALL PUBLISHERS 1987.