

**WIRELESS POWER
TRANSMISSION; PAST
FUTURE POSSIBLE
ADVANCEMENT.**

ADOKPA JEREMIAH ADAKOLE

2006/25787EE

**A thesis submitted to the department of
Electrical and Electronics Engineering, Federal
University of Technology Minna.**

November 2011

DEDICATION

This work is dedicated to my loving parents Mr & Mrs E.O. Adokpa and siblings (Samuel, Grace, Gloria, Daniel, Elizabeth, Hellen, and Abigail) for their unwavering support, to all my lecturers who have imparted knowledge in me.

DECLARATION

I hereby declare that this work was done by me and has never been presented elsewhere for the award of a degree. I also hereby relinquish the copyright to the Federal University of Technology, Minna.

Adokpa Jeremiah Adakole

.....

(Name of Student)



14/11/2011

(Signature and date)

CERTIFICATION

I hereby certify that this project "Wireless Power Transmission; Past and Future Possible Advancement" was carried out by Adokpa Jeremiah Adakole with matriculation number 2006/25787EE and meets the standard deemed acceptable by the department of Electrical and Electronics Engineering, school of Engineering and Engineering Technology, Federal University of Technology, Minna.

Mr. Ovewobi Stephen

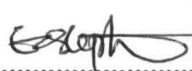
 4/11/2012

(Supervisor)

(Signature and date)

Engr. A.Raji

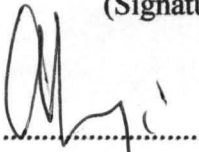
 (March 15, 2012)

(Name of H.O.D)

(Signature and date)

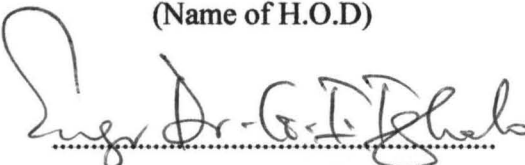

(External Examiner)

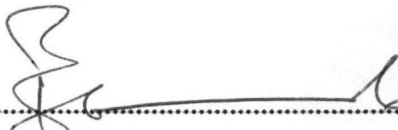
 6/3/2012

(Signature and date)

ACKNOWLEDGEMENT

I acknowledge the Almighty God for His sustenance ~~throughout~~ ^{and future} my stay in school, my supervisor Mr. Oyewobi Stephen, Mrs. Asindi, Total ~~ERP~~ ^{ERP} Scholarship, friends, lecturers and technicians who were always on point to give ~~their support as~~ ^{their support as} required during my project.

ABSTRACT

One of the key technologies throughout the 20th century was the application of radio for telecommunications. However, radio can also be used for other purposes such as human welfare. Due to a lack of energy supply during the next fifty years, Space Solar Power Station (SPS) could help solve the problem. Microwave wireless power transmission (MPT) is a promising technique for the long term power supply for places where it is difficult to install power transmission lines. This technology was proposed by W. C. Brown in 1960. In 1968 the initial idea of the SPS was proposed by P. E. Glaser. This research work describes a review of the research activities and future trends of microwave wireless power transmission (MPT) technology and its application.

TABLE OF CONTENT

TITLE	PAGE
Title Page.....	i
Dedication.....	ii
Declaration.....	iii
Certification.....	iv
Acknowledgement.....	v
Abstract.....	vi
Table of Content.....	vii-x
List of Figures.....	xi
List of Tables.....	xii
Chapter One:	1
1.0 Introduction.....	1
1.1 Preamble.....	1-2
1.2 Advantages of Wireless Power Transmission.....	3
1.3 Project Objectives.....	3
1.4 Scope.....	3

Chapter Two:	4
2.0 Literature Review.....	4
2.1 Need For Wireless Power Transmission.....	4
2.2 History of Wireless Power Transmission.....	4-7
2.3 Modes of Transmission.....	7
2.3.1 Radiative Mode.....	8
2.3.2 Non-Radiative Mode.....	8
2.3.2.1 Magnetic Coupled Resonance.....	9
Chapter Three	10
3.0 Magnetic Coupled Resonance.....	10
3.1 Mechanism of Operation.....	10-11
3.2 Application of Witricity.....	12
3.2.1 Medical Implantable Device.....	12
3.2.2 Electric Automobile.....	12-13
3.2.3 Device Recharging.....	13
3.3 Advantages of Magnetically Coupled Resonance Over Other Forms of WPT.....	14
3.4 Far-Field/Radiative Transfer.....	14

3.5	Microwave Power Transmission (MPT).....	15-16
3.6	Laser Power Transmission.....	17
3.7	Components of Wireless Power Transmission System.....	17
3.7.1	Microwave Generator.....	17-18
3.7.2	Transmitting Antenna.....	18
3.7.3	Receiving Antenna (Rectenna).....	19-20
3.8	Pros And Cons: Lasers Vs Microwave.....	20
3.8.1	Size Reduction.....	20-21
3.8.2	Interference.....	21
3.8.3	Atmospheric & Weather Effects.....	22
3.8.4	Safety.....	23
3.8.5	Geopolitics.....	23
3.8.6	Technical Maturity.....	23-24
3.9	Advantages of WPT.....	24
3.10	Disadvantages.....	25
3.10.1	Interference With Existing Wireless System.....	25-26
3.10.2	Safety on Ground.....	26-27

3.10.3 Interference With Space Plasma.....	27-28
3.10.4 Line of Sight (LOS).....	28
3.11 Space Based Solar Power (SBPS).....	28-29
3.12 Operational Concept.....	29-30
3.12.1 Solar Energy Conversion- Solar Photons to DC.....	30-31
3.12.2 Converting DC to Microwave Power.....	31
3.12.3 Transmitting Antennae.....	32-33
3.12.4 Transmission.....	33-34
3.12.5 Ground Segment- Reception.....	34-35
3.13 Highlights of SBSB.....	35
3.14 Advantages of Space Solar Power Over Other Forms of Power.....	36
3.15 Disadvantages of Space Solar Power (SPS).....	37
3.16 Future Solar Power Application.....	37
3.16.1 Interstellar Exploration.....	37-38
3.16.2 Planetary Defense.....	38
3.16.3 Commercial Uses.....	38

LIST OF FIGURES

Fig. 3.1	A Resonator.....	11
Fig. 3.2	Wireless Electricity Over 2 meters.....	11
Fig. 3.3	Resonant Inductive Recharging.....	13
Fig. 3.4	Functional Block Diagram of a WPT System.....	15
Fig. 3.5	First Ground-to-Ground MPT Experiment.....	16
Fig. 3.6	Space Energy Capture.....	29
Fig. 3.7	Shows a design of Earth Receiving Station (Rectenna).....	30
Fig. 4.1	Diffraction of a Wave.....	40
Fig. 4.2	Negative Refractive Index of Metamaterials.....	41
Fig. 4.3	A full View of a Fabricated Negative Index Metamaterial Structure.....	42
Fig. 4.4	Mechanism of WPT Using Negative Index Metamaterial.....	43

TABLES

Table 3.1	Typical parameter of the Transmitting Antenna of the SPS.....	19
Table 3.2	Rectenna Efficiency For Various Diodes at Different Frequency.....	20
Table 3.3	WPT Wavelength Trade For SPS.....	24

transmission efficiency.

One of the major applications of the Far-field technique will be in the transmission of power from Solar Power Satellite (SPS). Solar power captured on the Earth is familiar to us. However, an alternative approach to exploiting solar power is to capture it in space and convey it to the Earth by wireless means. As with terrestrial capture, Space Solar Power (SSP) provides a clean, safe and reliable source of power. The power collecting platforms would most likely operate in geosynchronous orbit where they would be illuminated 24 hours a day (except for short eclipse periods around the equinoxes). The power generated from this SPS would be transmitted to Earth using either microwave beam or Laser.

While the Far-field technique of Wireless Power Transmission (WPT) relies on propagating electromagnetic waves, the Inductive coupling (or near field) techniques do not rely on propagating electromagnetic waves. Instead, they operate at distances less than a wavelength of the signal being transmitted. Applications include rechargeable toothbrushes and the recently proliferating power surface. These techniques can be very efficient, but are limited to transmission distances of about a centimeter. Alternatively, near field RFID pushes the limit on distance by sacrificing efficiency.

Previously demonstrated magnetically coupled resonators used for wireless power transfer have shown the potential to deliver power with more efficiency than far-field approaches and at a longer range than traditionally inductively coupled schemes. However, this prior work is limited to a fixed distance and orientation, with efficiency falling off rapidly when the receiver is moved away from its optimal operating point.

1.2 Advantages of WPT

1. Users can be allowed to seamlessly recharge mobile devices easily as data is transmitted through the air.
2. In countries where terrain and topology are barriers impeding against installation of heavy sub-station and pylons to run high tension cables, their difficulties will be solved by WPT.
3. This system would reduce the cost of electric charge used by the consumer and rid the landscape of wires, cables and transmission towers.
4. The power failure due to short circuit and faults on cables will never exist in wireless power transmission.

1.3 Project Objectives

1. To bring into harmony many concepts, research papers, patents which are available on Wireless Power Transmission.
2. To meet the earth's demand of electric power.
3. For enhanced planetary exploration.

1.4 Scope

The scope of this work is limited to the Far-field method of wireless power transfer.

CHAPTER TWO

2.0 Literature Review

2.1 Need for Wireless Power Transmission

The world will need greatly increase energy supply for the next 20 years, especially generated electricity, (energy star). Electricity demand is increasing twice as fast as the overall energy use and is likely to rise by 76% in 2030 (world energy outlook 2009).

The conventional method of electric power generation, transmission and distribution poises both environmental and health hazard. Power generation accounts for about one quarter of the total emissions of carbon dioxide, been the main culprit in global warming [science daily (Nov. 15, 2007)]. For example the science daily [Nov. 15, 2007] puts the total emissions of carbon dioxide from power generating plants as one-quarter, the main culprit in global warming.

All these threats poised by the conventional system of power generation and transmission calls for an alternative mode of power transfer which is safer, reliable and environmentally friendly.

2.2 History of Wireless Power Transmission (WPT)

In 1864, James C. Maxwell predicted the existence of radio waves by means of mathematical model. In 1884, John H. Poynting realized that the Poynting Vector would play an important role in quantifying the electromagnetic energy. In 1888, bolstered by Maxwell's theory, Heinrich Hertz first succeeded in showing experimental evidence of radio waves by

his spark-gap radio transmitter. The prediction and evidence of the radio wave in the end of the 19th century was the start of the wireless power transmission revolution.

At the same period Marchese G. Marconi and Reginald Fessenden who were pioneers of communication via radio waves, and Nicola Tesla suggested an idea of the wireless power transmission and carried out the first WPT experiment in 1899[6, 7]. He said "This energy will be collected all over the globe preferably in small amounts, ranging from a fraction of one to a few horse-power. One of its chief uses will be the illumination of isolated homes". He actually built a gigantic coil which was connected to a high mast of 200-ft with a 3 ft-diameter ball at its top. He fed 300 kW power to the Tesla coil which resonated at 150 kHz. The Radio Frequency(RF) potential at the top sphere reached 100 MV. Unfortunately, he failed because the transmitted power was diffused to all directions with 150 kHz radio waves whose wave length was 21 km. To concentrate the transmitted power and to increase transmission efficiency, we have to use higher frequency than that used by Tesla.

In 1930s, there was much progress in generating high-power microwaves, 1-10 GHz radio waves, was achieved by invention of the magnetron and the klystron. After World War II, high power and high efficient microwave tubes were advanced by development of radar technology. We can concentrate the microwave power to receiver. We call the wireless power transmission with microwaves as microwave power transmission (MPT).

Based on the development of the microwave tubes during the World War II, W. C. Brown started the first MPT research and development in 1960s. First of all, he developed a rectenna, rectifying antenna which he named, for receiving and rectifying microwaves. The efficiency of the first rectenna developed in 1963 was 50% at an output of 4WDC and 40% at an output of 7WDC[8]. With the rectenna, he succeeded in MPT experiments to wired

experiment with MPT in 1987 which was called SHARP (Stationary High Altitude Relay Platform) with 2.45 GHz [13].

In USA, there are many MPT research and development after W. C. Brown, for instance, retrodirective microwave transmitters, rectennas, new devices and microwave circuit technologies.

In Japan, there were many field MPT experiments such as fuel-free airplane flight experiment with MPT phased array using 2.411 GHz in 1992[14], ground-to-ground MPT experiment with power company and universities in 1994-95[15] using 2.45 GHz, fuel-free airship flight experiment with MPT in 1995[16] using 2.45 GHz, development of SPS demonstrator with 5.8 GHz in 2000[17].

Some kinds of microwave transmitters, some kinds of retrodirective microwave transmitters, and many rectennas were also developed in Japan. In Europe, some unique technologies are developed. They plan ground-to-ground MPT experiment in Re-union Island[18,19].

As described before, there is only quiet small difference between the WPT and wireless communications.

2.3 Modes of Transmission

Basically, Wireless Power Transmission can be classified into two,

- i. Radiative Mode or Far Field Transmission
- ii. Non Radiative Mode or Near Field Transmission

CHAPTER ONE

1.0 Introduction

1.1 Preamble

In our present electricity generation system we waste more than half of its resources. Especially the transmission and distribution losses are the main concern of the present power technology. Much of this power is wasted during transmission from power plant generators to the consumer. The resistance of the wire used in the electrical grid distribution system causes a loss of 26-30% of the energy generated. This loss implies that our present system of electrical distribution is only 70-74% efficient. We have to think of an alternative state-of-the-art technology to transmit and distribute the electricity.

Now-a-days global scenario has been changed a lot and there is tremendous development in every field. If we don't keep pace with the development of new power technology we have to face a decreasing trend in the development of power sector. The transmission of power without wires may be one noble alternative for electricity transmission

Presently, several wireless power techniques are being pursued. It is useful to categorize these efforts in terms of their underlying power transfer mechanism to understand implication for range, adaption and efficiency.

Far field techniques uses propagating electromagnetic waves that transfer energy the same way radios transmit signals. This method has been successfully used to power UHF RFID tags, which have no batteries and at an operating range of ~10 meters. One of the drawbacks to far-field approaches is the inherent tradeoff between directionality and

2.3.1 Radiative Mode

This is known as wireless power transfer by electromagnetic radiation. Though the physics of both information and power transmission are related, for power transmission, efficiency is a more critical parameter, unlike the transmission of information where the percentage of power received is only important if it becomes too low to successfully recover the signal. Therefore, to satisfy the efficiency of received power, microwaves or laser are employed to convey this energy. This is because microwaves travel through the atmosphere more easily (as they are less prone to atmospheric attenuation) and the process of their conversion is quite efficient (> 95%) using the rectenna. Wireless power transmission is well proven. Experiments in tens of kilowatts have been performed[2]. These methods achieved through distance on the order of kilometers.

In order to actually convey a reasonable amount of energy sufficient for powering electrical devices over such appreciable distances, negative health implications could be incurred. The issue of an uninterrupted line of sight, which may not be practical comes to play.

2.3.2 Non-Radiative Mode

The Non-Radiative mode of wireless power transmission can generally be said to take place via electromagnetic coupling. This is through a process called induction. This is simply the principle behind the operation of electrical transformers. The same is applicable in the electric toothbrush and the splash power recharging mat[3]. However, the main drawback is the very short range. The receiver must be in close proximity to the transmitter in order to couple inductively.

2.3.2.1 Magnetically coupled resonance

Non-Radiative transmission was recently demonstrated differently in 2006 by a research group at the Massachusetts Institute of Technology (MIT)[3] where it was called Witricity. The principle on which magnetically coupled resonance is based as put together by the MIT team states that two resonant objects of the same resonant frequency tend to exchange energy efficiently, while interacting weakly with extraneous off-resonant objects.

They explored a system of two electromagnetic resonators coupled through their magnetic fields; they were able to identify the strongly coupled regime, even when the distance between them was a couple of meters and larger than the sizes of the resonant objects, efficient power transfer was enabled. This is so suitable because, the fact that magnetic fields interacts so weakly with bio-organisms is important for safety considerations.

CHAPTER THREE

3.0 Magnetically Coupled Resonance

The most recent breakthrough in wireless power transmission is based on using coupled resonators. This is referred to as non-radiative power transfer since it involves stationary fields around the coils rather than fields that spread in all directions. Two resonant objects of the same resonant frequency tend to exchange energy efficiently, while interacting weakly with extraneous off-resonant objects. A good instance is the process of energy transmission via acoustic resonance. Let's consider a room with 100 identical wine glasses, each filled with wine up to a different level, so they all have different resonant frequencies. If an opera singer sings a sufficiently loud single note inside the room, a glass of the corresponding frequency might accumulate sufficient energy to even explode, while not influencing the other glasses. This is why playing a trumpet can cause a nearby trumpet to vibrate. Both trumpets have the same resonant frequency. Induction can take place a little differently if the electromagnetic fields around the coils resonate at the same frequency.

3.1 Mechanism of Operation

The system consists of two copper (ring-shaped copper antennas) coils, each a self-resonant system. The transmitting coil as it is connected to the alternating current (a.c.) mains generates a magnetic field as current flows through the coils. The receiving coil is a single layer solenoid with closely spaced capacitance plates on each end (see fig. 3.1), which in combination allows the coil to be tuned to the transmitter frequency thereby eliminating the

wide energy wasting wave problem and allowing the energy used to focus in on a **specific** frequency increasing the range.

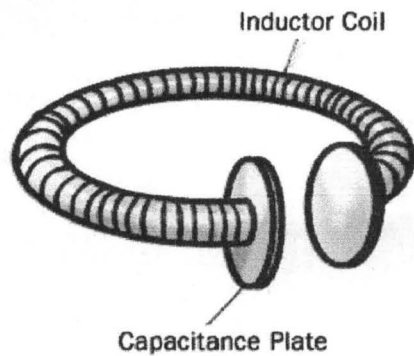

©2007 HowStuffWorks

Fig. 3.1 A Resonator

Electricity, traveling along an electromagnetic wave, can tunnel from one coil to the other as long as they both have the same resonant frequency. In this way, streams of energy move from the transmitting coil to the receiving coil.

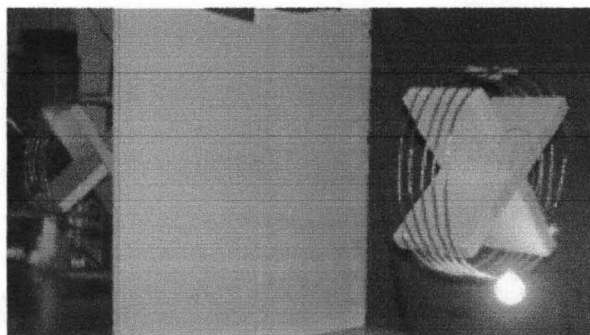

Fig.3.2 Wireless Electricity over 2meters, Demonstrated While Blocking the Line of Sight

3.2 Application of Witricity

Some wireless resonant inductive devices operate at low milli watt power levels and are battery powered. Others operate at higher kilowatt power levels. Current implantable medical and road electrification device designs achieve more than 75% transfer efficiency at an operating distance between the transmitting and receiving coils of less than 10 cm.

3.2.1 Medical Implantable Devices

Resonant inductive wireless energy transfer is used successfully in implantable medical devices including such devices as pacemakers and artificial hearts. While the early systems used a resonant receiver coil later systems implemented resonant transmitter coils as well. These medical devices are designed for high efficiency using low power electronics while efficiently accommodating some misalignment and dynamic twisting of the coils. The separation between the coils in implantable applications is commonly less than 20 cm. Today resonant inductive energy transfer is regularly used for providing electric power in many commercially available medical implantable devices.

3.2.2 Electric Automobiles

Wireless electric energy transfer for experimentally powering electric automobiles and buses is a higher power application (>10kW) of resonant inductive energy transfer. High power levels are required for rapid recharging and high energy transfer efficiency is required both for operational economy and to avoid negative environmental impact of the system. An experimental electrified roadway test track built circa 1990 achieved 80% energy efficiency

while recharging the battery of a prototype bus at a specially equipped bus stop. The bus could be outfitted with a retractable receiving coil for greater coil clearance when moving. The gap between the transmitting and receiving coils was designed to be less than 10 cm when powered. In addition to buses the use of wireless transfer has been investigated for recharging electric automobiles in parking spots and garages as well.

3.2.3 Device Recharging

This technology enables cell phones, household robots, mp3 players, laptop computers and other portable electronics to charge without ever being plugged in. Placing one of these wireless chargers in each room of a home or office could provide coverage throughout the building.

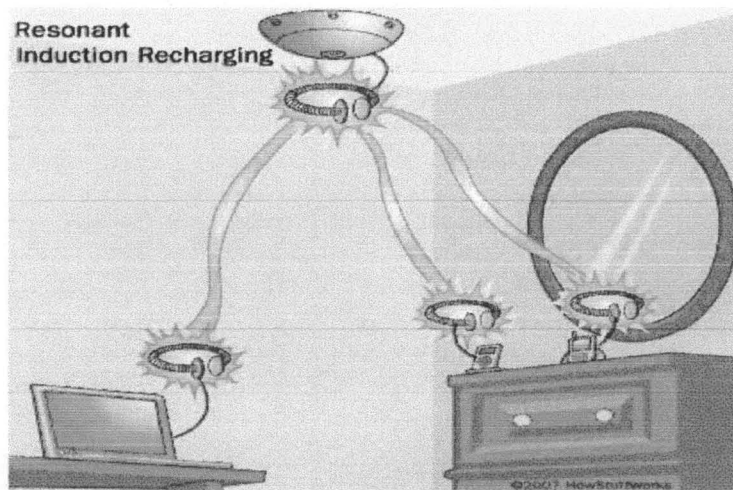

Fig. 3.3 Resonant Inductive Recharging

3.3 Advantages of Magnetically Coupled Resonance over Other Forms of WPT

1. The advantage of using the non-radiative evanescent fields lies in the fact that most of the power not picked up by the receiving coil remains bound to the vicinity of the sending unit, instead of being radiated into the environment and lost.
2. Power levels more than sufficient to run a laptop can be transferred over room-sized distances nearly Omni-directionally and efficiently, irrespective of the geometry of the surrounding space, even when environmental objects completely obstruct the line-of-sight between the two coils. (see fig. 3.2)
3. The non-radiative mode rules out the possibility of incurring health risks unlike in the radiative mode where electromagnetic waves are beamed.

3.4 Far-Field/Radiative Transfer

It is known that electromagnetic energy is also associated with the propagation of the electromagnetic waves. We can use theoretically all electromagnetic waves for a wireless power transmission (WPT). The difference between WPT and communication systems is only efficiency.

The Maxwell's Equations indicate that all electromagnetic field has its power diffuse to all directions. Although we transmit the energy in the communication system, the transmitted energy is diffused to all directions. Although the received power is enough for the transmission of information, the efficiency from the transmitter to receiver is quite low. Therefore, we do not call it a WPT system.

3.5 Microwave Power Transmission (MPT)

William C. Brown, the pioneer in wireless power transmission technology, has designed, developed a unit and demonstrated to show how power can be transferred through free space by microwaves. The concept of Wireless Power Transmission System is explained with functional block diagram shown in Figure 3.4.

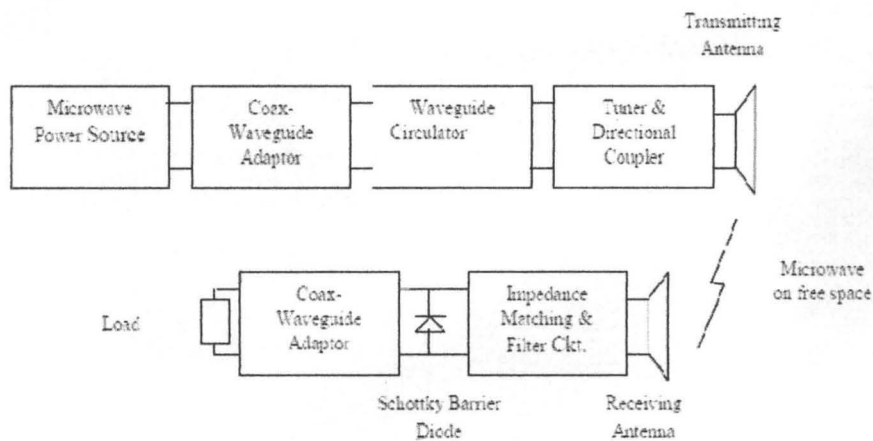

Fig 3.4 Functional Block diagram of a WPT System

On the transmission side, the microwave power source generates microwave power and the output power is controlled by electronic control circuits. The wave guide ferrite circulator which protects the microwave source from reflected power is connected with the microwave power source through the Coax-Waveguide Adaptor. The tuner matches the impedance between the transmitting antenna and the microwave source. The attenuated signals will be then separated based on the direction of signal propagation by Directional Coupler. The transmitting antenna radiates the power uniformly through free space to the rectenna.

In the receiving side, a rectenna receives the transmitted power and converts the microwave power into DC power. The impedance matching circuit and filter is provided to setting the output impedance of a signal source equal to the rectifying circuit. The rectifying circuit consists of Schottky barrier diodes which converts the received microwave power into DC power.

Microwave-to-DC conversion efficiency from 40% to 84% has been achieved. The efficiency being defined as the ratio of DC output to microwave power absorbed by the rectenna. The highest record of 84% efficiency was attained in a demonstration of microwave power transmission in 1975 at the JPL Goldstone facility. Power was successfully transferred from the transmission large parabolic antenna dish to the distance rectenna site over a distance of 1.6Km. The DC output was 30Kw.

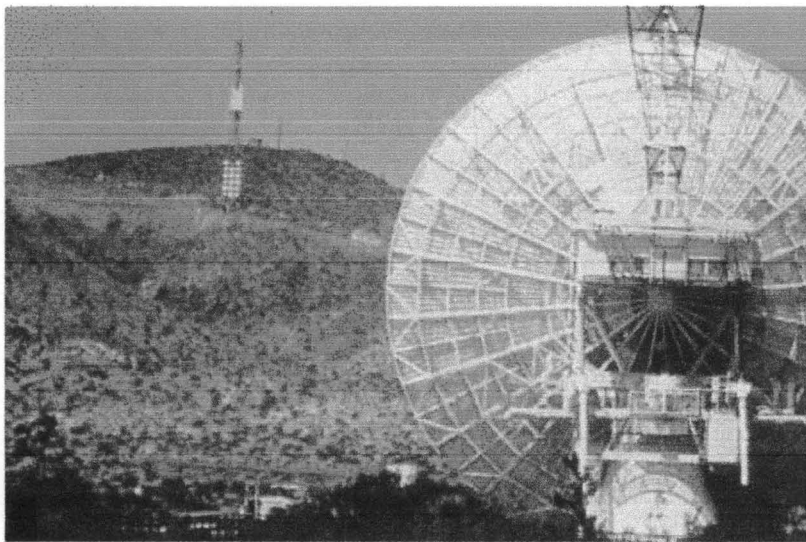

Fig 3.5 First Ground-to-Ground MPT Experiment

3.6 Laser Power Transmission

In principle, all lasers can be used for transmitting power. The most efficient DC-to-laser converters are solid-state laser diodes commercially employed in fiber optics and free-space laser communication. Alternatively, direct solar-pumping laser generation has a major advantage over conventional solid state or gas lasers, which rely on the use of electrical energy to generate laser oscillation since the generation of electricity in space implies automatically a system level efficiency loss of roughly 60%. To generate a laser beam by direct solar pumping, solar energy needs to be concentrated before being injected into the laser medium. The required concentration ratio is dependent on the size of the laser medium, the energy absorption ratio and the thermal shock parameter (weakness of the material to internal stress caused by a thermal gradient)

3.7 Components of WPT System

The Primary components of Wireless Power Transmission are Microwave Generator, Transmitting antenna and Receiving antenna (Rectenna). The components are described below.

3.7.1 Microwave Generator

The microwave transmitting devices are classified as Microwave Vacuum Tubes (magnetron, klystron, Travelling Wave Tube (TWT), and Microwave Power Module (MPM)) and Semiconductor Microwave transmitters (GaAs MESFET, GaN pHEMT, SiC MESFET, AlGaIn/GaN HFET, and InGaAS). Magnetron is widely used for experimentation

Table 3.1 Typical Parameter of the Transmitting antenna of the SPS [21]

Model	Old JAXA Model	JAXA1 Model	JAXA2 Model	NASA/DOE Model
Frequency	5.8GHZ	5.8GHZ	5.8GHZ	2.45GHZ
Diameter Of transmitting antenna	2.6Km	1Km	1.93Km	1Km
Output Power (beamed to Earth)	1.3GW	1.3GW	1.3GW	6.72GW
Max. Power Density at Center	63mW/cm ²	420mW/cm ²	114mW/cm ²	2.2W/cm ²
Minimum Power Density at Edge	6.3mW/cm ²	42mW/cm ²	11.4mW/cm ²	0.22W/cm ²
Antenna Spacing	0.75	0.75	0.75	0.75
Power per Antenna (Number of Elements)	Max.0.95W (3.54 billion)	Max. 6.1W (540 million)	Max. 1.7W (1.950 million)	Max. 185W (97 million)
Rectenna Diameter	2.0Km	3.4Km	2.45Km	1km
Max. Power Density	180mW/cm ²	26mW/cm ²	100mW/cm ²	23mW/cm ²
Collection Efficiency	96.5%	86%	87%	89%

JAXA; Japan Aerospace Exploration Agency, NASA; National Aeronautics and Space Administration, DOE; U.S Department of Energy.

3.7.3 Receiving Antenna (Rectenna)

The concept, and the name 'rectenna' was conceived by W.C. Brown of Raytheon Company in the early of 1960s. The rectenna is a passive element which consists of antenna, rectifying circuit with a low pass filter between the antenna and rectifying diode. The antenna used in rectenna may be dipole, Yagi – Uda, microstrip or parabolic dish antenna. The patch dipole antenna achieved the highest efficiency among them all. Schottky barrier diodes (GaAs, Si) are usually used in the rectifying circuit due to its faster reverse recovery time and

much lower forward voltage drop and good RF characteristics. The rectenna efficiency for various diodes at different frequency is shown in Table 3.2 below

Table 3.2 Rectenna Efficiency for various Diodes at Different Frequency[23].

Frequency (GHZ)	Schottky Diode	Measured Efficiency (%)	Calculated Efficiency (%)
2.45	GaAS	92.5	90.5
5.8	Si	82	78.3
8.51	GaAs	62.5	66.2

3.8 Pros And Cons: Lasers Vs Microwaves

3.8.1 Size Reduction.

By far the most important benefit of laser beaming over microwaves is the reduction in size of the transmitting and receiving antennas. The beam diameter needed to carry a given amount of power varies approximately with the wavelength of the beam. Because the wavelengths of lasers are about 5 orders of magnitude shorter than microwaves, the power transmitter and receiver can be much smaller; that is, meters rather than kilometers in diameter for power levels in the hundreds of megawatts.

The diffraction of a power beam also varies roughly with wavelength, so the spreading of a laser beam will be much less than that of a microwave beam. For distances that may range up to 35,000 km (for a geostationary-orbit power satellite), this reduces the receiving antenna's land-area requirements still further, with obvious cost-reduction

consequences.

37

The size reduction of the space-based transmitting antenna also has significant cost-reduction impact. In volume-limited space transport, for example, an entire laser system could be orbited in a single launch. The ability to field smaller systems may also allow a lower total power level laser system to be economically competitive with a much higher power microwave system in terms of both installed capital cost (\$/kW) and operating cost (cents/kWh).

3.8.2 Interference.

A major issue in space solar power systems employing microwave power transmission is their potential interference with satellite communication systems, which use frequencies in the same multi-gigahertz range that is best suited to microwave power transmission. The filtering and/or frequency restrictions necessary to avoid such interference could be a major barrier to the economics of space-based power systems for terrestrial consumption, and obtaining their approval by the Federal Communications Commission and the International Telecommunications Union may be extremely difficult due to the potential interference with the ubiquitous global satellite communication services.

Lasers, however, avoid these interference issues, both because of the great disparity in fundamental frequencies between lasers and satellite communications bands (a difference of roughly five orders of magnitude) and the fact that the narrow laser beams are less likely to have significant sidelobes that could introduce interference.

3.8.3 Atmospheric and Weather Effects.

Both microwave and laser beams are attenuated by the Earth's atmosphere and its weather dependent particulate content. Attenuation due to scattering is highest when the wavelength is comparable to the size of the particles in the atmosphere. Because of the much shorter wavelength of laser beams, they are much more severely attenuated than microwave beams, to the extent that power beam interruptions to the terrestrial utility station will occur.

The longer-wavelength microwaves past through rain and clouds with only small attenuation and scattering. Glaser's original concept and the early NASA/DOE studies were based on microwave power transmission at 2.45 GHz, a frequency whose wavelength is long enough to be nearly unaffected by weather.

However, the abovementioned interference considerations and size-related system economics may dictate the use of higher microwave frequencies, which could introduce greater weather effects. But these effects on microwave-based system would never be as severe as with laser transmission. As a result of their greater sensitivity to weather-induced attenuation, base-load electric utility systems employing laser power transmission will require many spatially diverse receiving sites to deal with weather outages. One approach would be to use ground-based energy storage; another is to transfer power from clear sites via an interconnected ground network. The incremental costs of either of these "fixes," along with the need for multiple sites, could compromise the economics of systems that use laser power transmission.

3.8.4 Safety.

Power beam safety is mandatory for both laser and microwave beams. Because the power flux density of a laser beam is much higher than that of a microwave beam for the same total power delivered, the consequences of any intrusion into the beam by people, animals, or artifacts can be much more serious for the laser than for the microwave beam. The physical laws that allow the laser beam diameter to be so small also make the microwave beam power per unit area lower, and hence potentially less damaging.

One advantage of the laser beam, however, is that if the wavelength of operation is suitably selected it is clearly visible due to diffraction by the atmosphere's normal aerosol content. The microwave beam is invisible and can only be felt by its thermal effects.

3.8.5 Geopolitics.

High-power space-based lasers will face political as well as safety challenges. For example, any space-based laser must comply with the treaty constraints of the 1972 US-Soviet antiballistic missile (ABM) treaty that prohibit space-based defenses having the ability to intercept long-range (strategic) ballistic missiles. Since the economics of wireless power transmission are highly dependent on the transported power level, any potential limitations must be known before investors would contribute to commercial laser beam power developments.

3.8.6 Technical Maturity.

The relative immaturity of laser power transmission technologies relative to those associated with microwave power beaming constitutes the major current barrier facing the

implementation of lasers for this application. However, major strides have been made in recent years in both military and commercial development programs. The overall efficiency of a laser power transmission system (from incident sunlight to the terrestrial power grid) is now estimated to be more than half that obtainable with a microwave system and the technology continues to improve.

Table 3.3 WPT Wavelength Trade for SSP [22]

ATTRIBUTE	WPT Using Microwaves	WPT Using Laser
Aperture Size	Large; So system must be large	Small; allows flexible system design +
Interference	Interference with Communication Systems.	None, except perhaps astronomy.+
Attenuation	Penetrates clouds and light rain +	Stopped by clouds
Legal Issues	FCC, NTIA, ITU	ABM treaty, if power density is high
Infrastructure	Rectenna useful for SSP only	PV array for both WPT & solar power +
Perception	Public fears of "cooking"	Government; fears of Weapon
Safety	Safe (must keep aircraft out of beam)	Safe (WPT light intensity < sunlight)
Efficiency(space)	High +	Improving
Efficiency(ground)	High +	Improving

Key

	Area of Significant Concern
	Intermediate Area
+	Area of Significant Benefit

3.9 Advantages of WPT

1. Wireless Power Transmission system would completely eliminates the existing high-tension power transmission line cables, towers and sub stations between the generating station and consumers and facilitates the interconnection of electrical generation plants on a global scale.
2. It has more freedom of choice for both receiver and transmitters. Even mobile transmitters and receivers can be chosen for the WPT system.
3. The cost of transmission and distribution become less and the cost of electrical energy for the consumer also would be reduced. The power could be transmitted to the places where the wired transmission is not possible.
4. Loss of transmission is negligible in the Wireless Power Transmission; therefore, the efficiency of this method is very much higher than the wired transmission.
5. Power is available at the rectenna as long as the WPT is operating. The power failure due to short circuit and fault on cables would never exist in the transmission and power theft would not be possible at all.

3.10. Disadvantages

3.10.1 Interferences with Existing Wireless System

Most MPT system adopted 2.45 GHz or 5.8 GHz band which are allocated in the ITU-R Radio Regulations to a number of radio services and are also designated for ISM (Industry, Science and Medical) applications. Conversely speaking, there is no allowed frequency band for the MPT, therefore, we used the ISM band. The bandwidth of microwave

for the MPT do not need wide band and it is quite narrow since an essentially monochromatic wave is used without modulation because we use only carrier of the microwave as energy.

Power density for the MPT is a few orders higher than that for the wireless communication. We have to consider and dissolve interferences between the MPT and the wireless communication systems.

3.10.2 Safety on Ground

One of the characteristics of the MPT is to use more intense microwave than that in wireless communication systems. Therefore, we have to consider MPT safety for human. In recent years there have been considerable discussions and concerns about the possible effect for human health by RF and Microwave radiation. Especially, there have been many research and discussions about the effects at 50/60 Hz and over GHz (microwave). These two effects are different. There is long history concerning the safety of the microwave. Contemporary RF/microwave standards are based on the results of critical evaluations and interpretations of the relevant scientific literature.

The SAR (specific absorption rate) threshold for the most sensitive effect considered potentially harmful to humans, regardless of the nature of the interaction mechanism, is used as the basis of the standard. The SAR is only heating problem. The scientific research results have indicated that the microwave effect to human health is only heating problem. This is different from the EMF research. The ICNIRP (International Commission on Non-Ionizing Radiation Protection) guidelines, are 50 or 10 W/m² for occupationally exposed and the general public, at either frequency. The corresponding limits for IEEE standards for maximum permissible human exposure to microwave radiation, at 2.45 or 5.8 GHz, are 81.6

or 100 W/m^2 as averaged over six min, and 16.3 or 38.7 W/m^2 as averaged over 30 min, respectively, for controlled and uncontrolled environments.

The controlled and uncontrolled situations are distinguished by whether the exposure takes place with or without knowledge of the exposed individual, and is normally interpreted to mean individuals who are occupationally exposed to the microwave radiation, as contrasted with the general public. In future MPT system, we have to keep the safety guideline outside of a rectenna site. Inside the rectenna site, there remains discussion concerning the keep out area, controlled or uncontrolled area.

3.10.3 Interaction with Space Plasma

When microwave from the Solar Power Solar (SPS) propagates through ionospheric plasmas, some interaction between the microwave and the ionospheric plasmas occurs. It is well known that refraction, Faraday rotation, scintillation, and absorption occur between weak microwave used for satellite communication and the plasmas. However, influence to the MPT system is negligible. For example, reflection through the ionosphere at 2.45 GHz and 5.8 GHz is only 0.67 m and 0.12 m , respectively, when it was calculated theoretically with Snell's law and total electron contents in the ionosphere. However, there is no interference because diameter of rectenna site will be over km.

It is theoretically predicted that it has possibility to occur Ohmic heating of the plasmas, plasma hall effect by Ponderomotive force, thermal self-focusing effect of the microwave beam, and three-wave interactions and excitation of electrostatic waves in MHz bands. These interactions will not occur in existent satellite communication systems because the microwave power is very weak.

3.10.4 Line of Sight (LOS)

Microwave beaming requires a direct line of sight (LOS) with the target device and in the case of a mobile receiving device, sophisticated tracking mechanism would be required. A typical instance is the unmanned plane designed in the 1980's by Canada's communication research centre that can run off power beamed from the earth. Rather than flying from point to point, it could only fly in circles within 2km diameter at an altitude of about 21kilometers. The plane had constant power supply as long as it was in the range of the functioning microwave array.

3.11 Space Based Solar Power (SBPS)

A potential application of particular interest is the use of lasers/microwave to beam power from solar collector in space to other locations both in space and on the Earth's surface. The concept of space solar power systems for terrestrial power delivery was first proposed by Glaser in 1968 and studied extensively by NASA, the Department of Energy, and others in the 1970s and 1980s. It was recently revisited by NASA in a "Fresh Look" study.

These space solar power concepts require a means for transmitting the electric power that is converted from solar energy by the space-based power conversion system (e.g., photovoltaic arrays) to the Earth's surface for subsequent terrestrial distribution as electric power. All the concepts studied to date, from Glaser's initial proposal to the 1998 studies just completed, have employed microwaves to meet this wireless power transmission requirement. Figure 4.1 below shows Space Energy Capture.

In the Far-field technique of WPT which find its largest application in Space Solar Power Satellite (SPS), four stages are involved

1. Space solar radiation collection and conversion to electrical power.
2. Conversion of this electrical power to laser/microwave radiation.
3. Wireless power transmission of this laser/microwave radiation to an end-use location.
4. Collection of the laser radiation and conversion to electrical power.

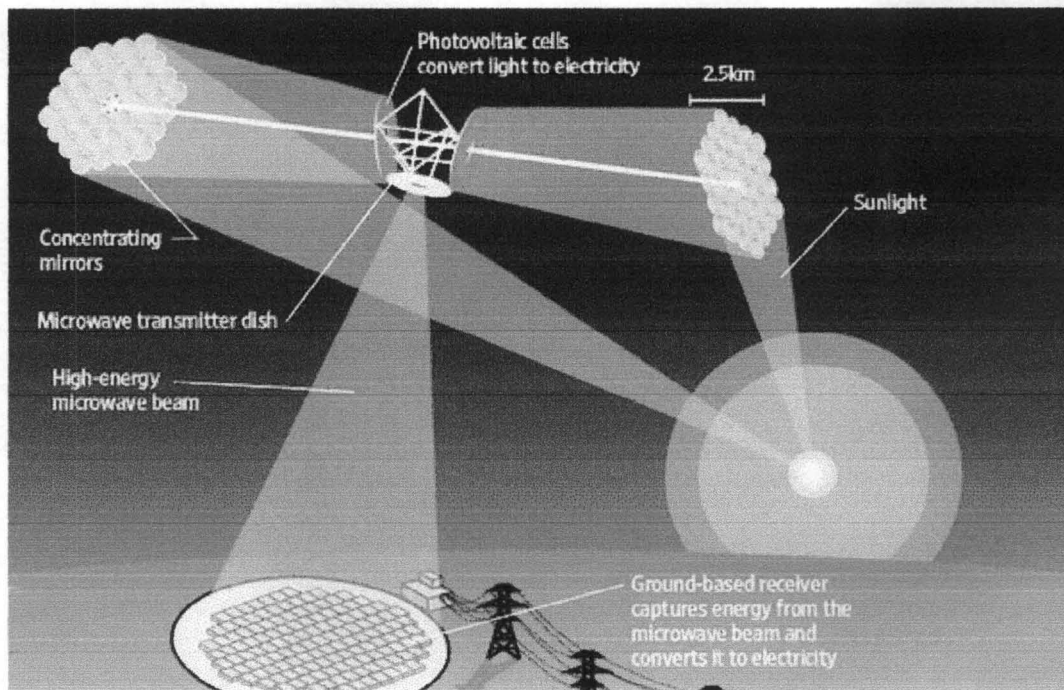

Fig 3.6 Space Energy Capture

3.12 Operational Concept

Antennas and rectifying antennas are crucial to WPT and in space solar power satellite (SPS). The SPS are gigantic satellite designed as an electrical power plant orbiting in the Geostationary Earth Orbit (GEO).

It consists of mainly three segments:

1. Solar energy collector to convert the solar energy into DC (direct current) electricity.
2. DC-to-Microwave/LASER converter.
3. A large antenna array to beam down the microwave/LASER power to the ground.

At the ground-base stations are rectifying antenna called Rectenna which collects this microwave power and converts it back to electricity for the grid.

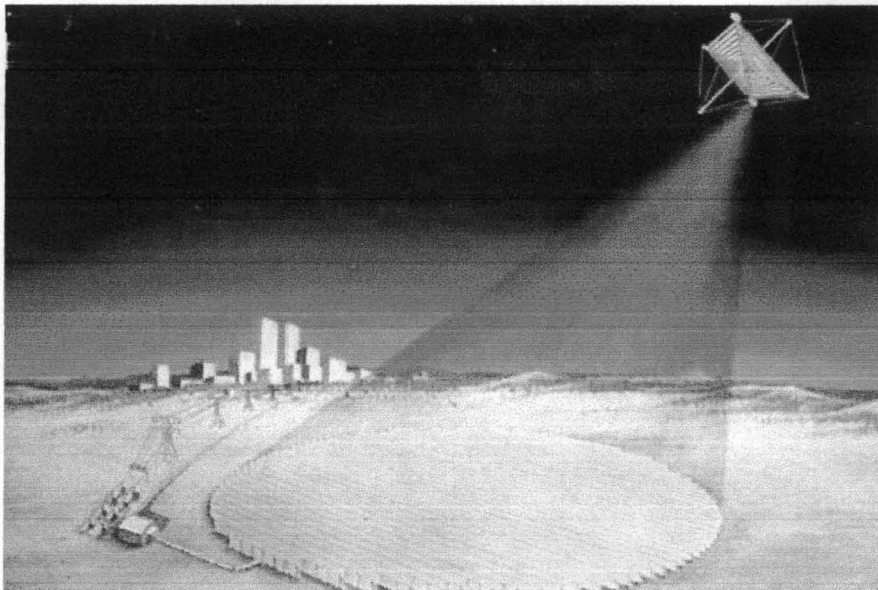

Fig.3.7 Shows a design of Earth Receiving Station (Rectenna)

3.12.1 Solar Energy Conversion - Solar Photons to DC

Two basic methods of converting sunlight to electricity have been studied: photovoltaic (PV) conversion, and solar dynamic (SD) conversion. Most analyses of solar power satellites have focused on photovoltaic conversion (commonly known as “solar

cells”). Photovoltaic conversion uses semiconductor cells (*e.g.*, silicon or gallium arsenide) to directly convert photons into electrical power via a quantum mechanical mechanism.

In an SPS implementation, photovoltaic cells will likely be rather different from the glass-pane protected solar cell panels familiar to many from current terrestrial use, since they will be optimized for weight, and will be designed to be tolerant to the space radiation environment (it turns out fortuitously, that thin film silicon solar panels are highly insensitive to ionizing radiation), but will not need to be encapsulated against corrosion by the elements. They do not require the structural support required for terrestrial use, where the considerable gravity and wind loading imposes structural requirements on terrestrial implementations.

3.12.2 Converting DC to Microwave Power

To convert the DC power to microwave for the transmission through antenna towards the earth’s receiving antenna, microwave oscillators like Klystrons, Magnetrons can be used. In transmission, an alternating current is created in the elements by applying a voltage at the antenna terminals, causing the elements to radiate an electromagnetic field.

The DC power must be converted to microwave power at the transmitting end of the system by using microwave oven magnetron. The heat of microwave oven is the high voltage system. The nucleus of high voltage system is the magnetron tube. The magnetron is diode type electron tube, which uses the interaction of magnetic and electric field in the complex cavity to produce oscillation of very high peak power. It employs radial electric field, axial magnetic field, anode structure and a cylindrical cathode.

A solar power satellite operating with 10 GW of radiated power would radiate a total power of one microwatt in a 400 Hz channel width.

3.12.3 Transmitting Antennae

Power transmission via radio waves can be made more directional, allowing longer distance power beaming, with shorter wavelengths of electromagnetic radiation, typically in the microwave range. Power beaming using microwaves has been proposed for the transmission of energy from orbiting solar power satellites to Earth and the beaming of power to spacecraft leaving orbit has been considered. [4][5]

The size of the components may be dictated by the distance from transmitter to receiver, the wavelength and the Rayleigh criterion or diffraction limit, used in standard radio frequency antenna design, which also applies to lasers. In addition to the Rayleigh criterion, Airy's diffraction limit is also frequently used to determine an approximate spot size at an arbitrary distance from the aperture.

The Rayleigh criterion dictates that any radio wave, microwave or laser beam will spread and become weaker and diffuse over distance; the larger the transmitter antenna or laser aperture compared to the wavelength of radiation, the tighter the beam and the less it will spread as a function of distance (and vice versa). Smaller antennae also suffer from excessive losses due to side lobes.

Ultimately, beam width is physically determined by diffraction due to the dish size in relation to the wavelength of the electromagnetic radiation used to make the beam.

Microwave power beaming can be more efficient than lasers, and is less prone to atmospheric attenuation caused by dust or water vapor losing atmosphere to vaporize the water in contact.

Then the power levels are calculated by combining the above parameters together, and adding in the gains and losses due to the antenna characteristics and the transparency of

the medium through which the radiation passes. That process is known as calculating a link budget.

However, the above mathematics does not account for atmospheric absorption which can be a severe damping effect on propagating energy in addition to causing severe fading and loss of quality.

3.12.4 Transmission

As the electro-magnetic induction and electro-magnetic radiation has disadvantages we are going for implementation of electrical conduction and resonant frequency methods. Of this, the resonant induction method is the most implement able due to the reasons given later. In the distant future this method could allow for elimination of many existing high tension power transmission lines and facilitate the inter connection of electric generation plants in a global scale.

The microwave source consists of microwave oven magnetron (see Fig 3.4) with electronics to control the output power. The output microwave power ranges from 50w to 200w at 2.45GHz. A coaxial cable connects the output of the microwave source to a coax-to-wave adaptor. This adaptor is connected to a tuning waveguide ferrite circulator is connected to a tuning waveguide section to match the wave guide impedance to the antenna input impedance.

The slotted wave guide antenna consists of 8 waveguide sections with 8 slots on each section. These 64 slots radiate the power uniformly through free space to the rectifying antenna (rectenna). The slotted waveguide antenna is ideal for power transmission because of its high aperture efficiency (>95%) and high power handling capability.

Microwaves are situated on the electromagnetic spectrum with frequencies ranging from 0.3 to 300 GHz.

The energy transmitted by a microwave is very diffusive in nature, such that the receiving antenna area must be very large when compared to the transmitter. Although the use of microwaves to transmit energy from space down to earth is attractive, most part of the microwaves receives significant interference due to atmosphere. Still there are certain frequency windows in which these interactions are minimized. The frequency windows in which there is a minimum of atmospheric signal attenuation are in the range of 2.45-5.8GHz, and also 35-38GHz; specifically we might expect losses of 2-6%, and 8-11% respectively for these two microwave signal ranges.

3.12.5 Ground Segment - Reception

The SPS system will require a large receiving area with a Rectenna array and the power network connected to the existing power grids on the ground. Although each rectenna element supplies only a few watts, the total received power is in the Gigawatts (GW).

A Rectenna may be used to convert the microwave energy back into electricity. Rectenna conversion efficiencies exceeding 95% have been realized. The word 'Rectenna' is formed from 'rectifying circuit' and 'antenna.'

A rectifying antenna called rectenna receives the transmitted power and converts the microwave power to direct current (DC) power. The rectenna is a passive element with a rectifying diode, and is operated without any extra power source. The rectenna has a low-pass filter between the antenna and the rectifying diode to suppress re-radiation of higher harmonics. It also has an output smoothing filter.

The Earth-based receiver antenna (or rectenna) is a critical part of the original SPS concept. It would consist of many short dipole antennas, connected via diodes.

Microwaves broadcast from the SPS will be received in the dipoles with about 85% efficiency. Rectenna would be multiple kilometers across. Crops and farm animals may be raised underneath a rectenna, as the thin wires used for support and for the dipoles will only slightly reduce sunlight, or non arable land could be used, so such a rectenna would not be as expensive in terms of land use as might be supposed.

3.13 Highlights of SBSP

The SBSP concept is attractive because space has several major advantages over the Earth's surface for the collection of solar power. There is no air in space, so the collecting surfaces would receive much more intense sunlight, unaffected by weather. In geostationary orbit, an SPS would be illuminated over 99% of the time. The SPS would be in Earth's shadow on only a few days at the spring and fall equinoxes; and even then for a maximum of 75 minutes late at night when power demands are at their lowest. This characteristic of SBSP avoids the expense of storage facilities (dams, oil storage tanks, coal dumps) necessary in many Earth-based power generation systems.

Additionally, SBSP would have fewer or none of the ecological (or political) consequences of fossil fuel systems.

3.14 Advantages of Space Solar Power over Other Forms of Power.

1. Unlike oil, gas, ethanol, and coal plants, space solar power does not emit greenhouse gases.
2. Unlike bio-ethanol or bio-diesel, space solar power does not compete for increasingly valuable farm land or depend on natural-gas-derived fertilizer. Food can continue to be a major export instead of a fuel provider.
3. Unlike nuclear power plants, space solar power will not produce hazardous waste, which needs to be stored and guarded for hundreds of years.
4. Unlike terrestrial solar and wind power plants, space solar power is available 24 hours a day, 7 days a week, in huge quantities. It works regardless of cloud cover, daylight, or wind speed.
5. Unlike nuclear power plants, space solar power does not provide easy targets for terrorists.
6. Unlike coal and nuclear fuels, space solar power does not require environmentally problematic mining operations.
7. Space solar power will provide true energy independence for the nations that develop it, eliminating a major source of national competition for limited Earth-based energy resources.

3.15 Disadvantages of Space Solar Power (SPS)

1. Maintenance of SPS is expensive and challenging.
2. Geosynchronous orbit is already in heavy use; could be endangered by space debris coming from such a large project.
3. The size of construction for the rectenna is massive.
4. Transportation of all the materials from earth to space and installation is highly challenging.

3.16 Future Solar Power Application

3.16.1 Interstellar Exploration.

Interstellar travel is difficult because it may take decades or centuries, and it requires a colossal amount of energy. The nearest star system is Alpha Centauri, which is 4.3 light-years away. If we travel at the speed of light it would take 8.6 years to reach it and to get the information back to Earth. If we assume a maximum velocity of 0.1 c for the spaceship in the acceleration and deceleration phases, the mission would take almost 43 years with an additional time of 4.3 years for the return of the data.

An interstellar probe requires gigawatts of energy. The actual energy requirements depend on the propulsion system efficiency in converting input energy into kinetic energy. A vehicle with a mass of 1000 kg travelling at the tenth of the speed of light would need 1018 J, which represents the total energy consumption of the United States over almost three weeks.

Some research on laser-beamed propulsion was done as part of the Strategic Defense Initiative. This technology relies in photonic pressure from a solar-pumped laser array to

push a vehicle with a large lightsail. The problem is that the transmitted laser power must be available for the vehicle at any time during the mission over interstellar distances. So, it would involve large diameter sails (on the order of 1000 km) 1000 km and large amounts of laser power (on the order of 10⁵ TW)

3.16.2 Planetary Defense.

Another use of such a phased-array laser beamer may be to focus intense power on the surface of potential Earth impacting asteroids or comets, creating jets of heated material having enough mass and velocity to change the object's orbit sufficiently to miss the Earth. Care would of course have to be taken to ensure that the object's composition would not favor fragmentation rather than the desired whole-body motion.

3.16.3 Commercial uses.

The power from space-based laser power "depots" could also be used to deliver power to next-generation high-power communication satellites and space stations or platforms, to support bases on the Moon, Mars, and perhaps satellites of the gas-giant planets, and to support assaying and mining missions to asteroids. Laser power beamers, used with various forms of propulsive devices, could transport materials from the Moon or asteroids to space-based manufacturing facilities, and could meet space tourism transportation needs by rapidly moving guests and their support materials among the moons and planets of the Solar System.

CHAPTER FOUR

4.0 Research Findings.

The approaches to wireless energy transmission can be categorized as near-field and far-field. To date, the latter is still impractical for consumer applications due to the high power and large antenna requirement necessary to achieve the levels of power comparable to a wall supply. To achieve a high power comparable to that of a wall outlet, the power of the microwave beam has to be increased and this might pose environment and health hazards. The large antenna size is due to the fact that, if we ignore the effects of absorption and scattering, the power density of electromagnetic waves in free space spread out such that the power density decrease is inversely proportional to the square of the distance. This means that Electromagnetic waves reduces very quickly because it spreads out so quickly. So a large reasonable size of the receiving antenna is needed to collect as much the wave as is possible.

To help in reducing the size of the antenna, metamaterial could be used. Metamaterial acts like a lense, focusing the EM waves so as to reduce its scattering and spreading out. Fig. 4.1 shows the diffraction of a wave as it propagates through space.

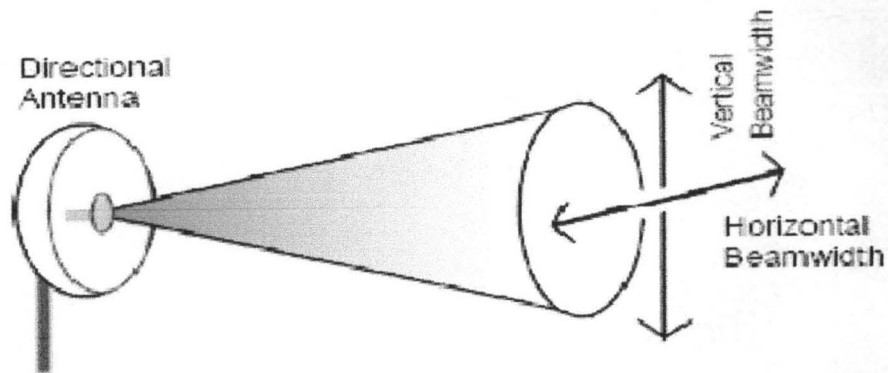

Fig. 4.1 Diffraction of a Wave

4.1 Electromagnetic Metamaterials

Interest in the field of artificial electromagnetic materials has been growing phenomenally since the “discovery” of materials that have been termed metamaterials[26] (MTM), also known as negative index material (NIM)[28], double negative media (DNM[29]), left-handed media (LHM)[30], backward wave media (BWM)[31], and negative refractive index media (NRI).

Electromagnetic metamaterials are artificially structured materials that are designed to interact with and control electromagnetic waves. Metamaterial is an artificial composite that the electro-magnetic properties can be engineered to achieve the extraordinary phenomena not observed in the natural materials as, for instance, negative refractive permittivity and permeability. The refractive permittivity and permeability of metamaterials arise from their structure rather than from the nature of their components, which are usually conventional conductors and dielectrics.

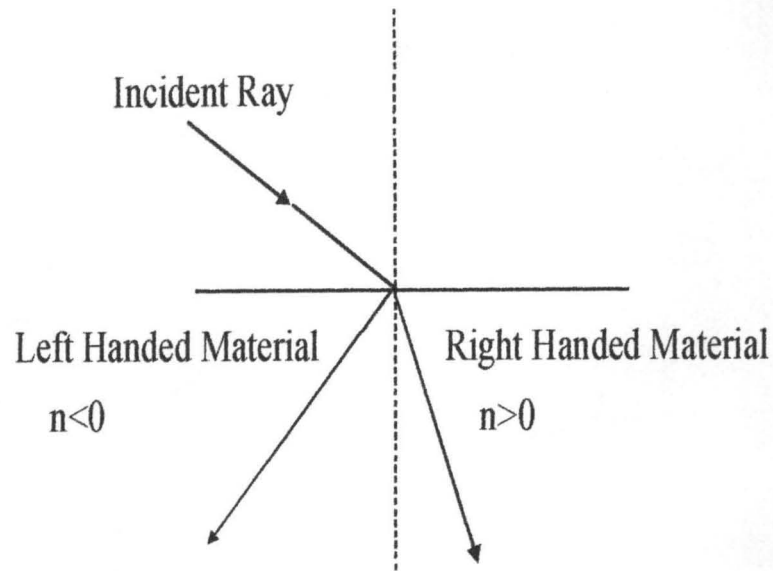

Fig. 4.2 Negative Refractive Index of metamaterial.

Almost arbitrary parameters can be achieved by carefully designing the elemental structures of metamaterials. Negative-index metamaterials (NIMs) are the first and one of most important metamaterials. It was first proposed by Veselago theoretically in 1968 [24], further investigated with realistic designs by Pendry in 2000 [27], and experimentally realized in 2001 [25]. Pendry showed that EM waves can propagate in a medium with ϵ and μ both negative. Negative refraction will happen at the interface between a regular medium (ϵ and μ both positive) and such a metamaterial [25].

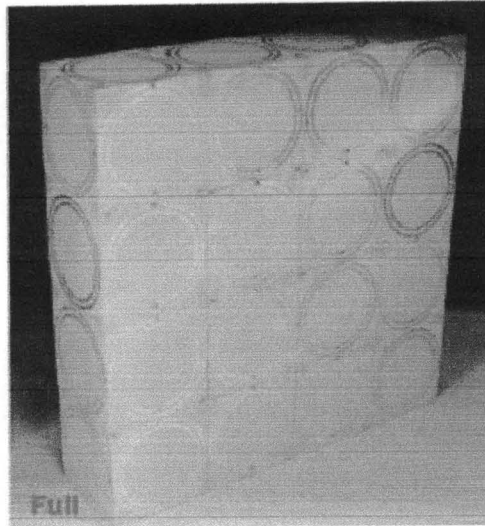

Fig. 4.3 A Full view of a fabricated negative index metamaterial structure.[26]

An essential characteristic of the metamaterials is that both the size of this element and periodicity are smaller than the wavelength of the electromagnetic fields that propagate through the structure.

4.2 Metamaterial and Efficiency In Wireless Power Transmission

One of the most noticeable properties of metamaterial is the ability of a metamaterial structure with relative permittivity and permeability, both equal to -1 , to behave as a magnetic "flux guide" with sub-wavelength resolution, that is, with a resolution smaller than the free-space wavelength of the impinging radiation. With a flat slab of NIM, negative refraction happens at both interfaces. So the propagating waves of an object can be focused inside the NIM slab and refocused outside.

Therefore, if we place the metamaterial structures with relative permeability equal to -1 between a RF magnetic field source and a receiving device (Rectenna), the structure will focus the magnetic field from the source towards the receiver. This mechanism can be

applied to improve the efficiency of energy transmission due to the fact that the radiation loss is reduced by focusing the magnetic field radiated outside the space between the source and the receiver in the wireless energy transmission system.

With the efficiency of the transmitted power improved by focusing the magnetic field, the size of the receiving (Rectenna) antenna will be greatly reduced.

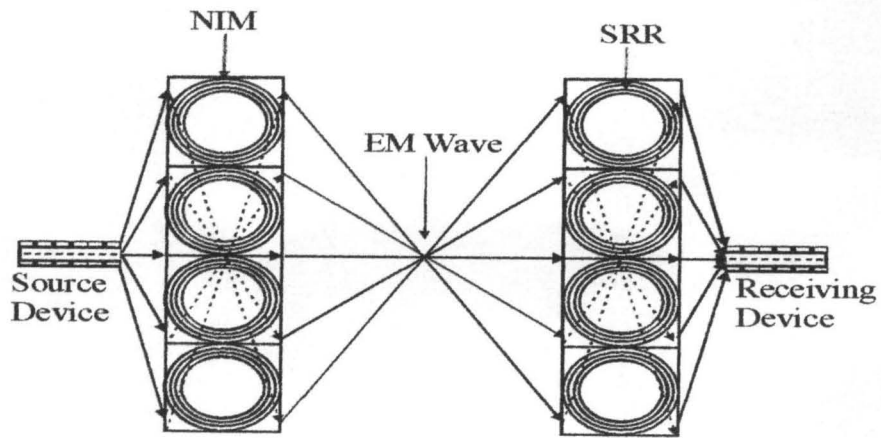

Fig 4.4 Mechanism of WPT Using Negative Index Metamaterial.

CHAPTER FIVE

5.0 Conclusion and Recommendations

5.1 Conclusion

Wireless Power transmission is a promising area of study. The ability to transport power over a long distance with high efficiency from a power generating facility on a satellite celestial body to earth would help the human population keep pace with its energy demand. Space Solar Energy captured in space would be beamed wirelessly to Earth-based station for terrestrial use.

5.2 Limitation

Since this project is mainly hypothetical, the major limitation is that it is not being implemented. This is due to the fact that the materials required for the implementation are too expensive.

5.3 Recommendation

Given the benefits of Wireless Power Transmission network, the following recommendations are made;

1. More research into totally harnessing this mode of power transmission should be undertaken.
2. Wireless power transmission standards should be set for proper component designs and specification.

REFERENCE

- [1] S. Sheik Mohammed, K. Ramasamy, T. Shanmuganatham, "Wireless Power Transmission- A Next Generation Power Transmission System", *International Journal of Computer Applications*(0975-8887), vol. 1-No. 13, 2010, pp. 101
- [2] <http://www.sspi.gatech.edu/wptshinohara.pdf>, Jun. 2011
- [3] Anand A. Trikolikar, Dr. Sanjay L. Nalbalwar, Lt. Milind P. Bhagat "Review of Wireless Power Transmission by Using Strongly Coupled Magnetic Resonance", *International Journal of Advanced Engineering and Applications*, Jan. 2010, pp 177
- [4] G. A. Landis, "Application for Space Power by Laser Transmission", *SPIE Optics, Electro-Optics & Laser Conference*, Los Angeles CA, January 1994, Vol.2121, pp 252-255
- [5] Barathway G, Srinag. K, "Wireless Power Transmission of Space Based Solar Power", 2nd International Conference on Environmental Science & Technology, Vol. 6, 2011, pp. V2-228
- [6] W. Brown, "The history of power transmission by radio waves", *Microwave Theory and Techniques*, IEEE Transaction on vol.32, no.9, sept. 1984, pp 1230-1242.
- [7] J. McSpadden and J. Mankins, "Space Solar Power Programs and microwave wireless power transmission technology", *Microwave Magazine*, IEEE, Jan.2009, pp 16-18
- [8] Powermat Inc. <http://www.powermat.com>, Feb. 2011
- [9] A.Karalis, J. Joannopoulos, and M. Soljacic, "Efficient Wireless Non-radiative mid-range energy transfer", *Annals of Physics*, vol. 323, no.1, Jan 2008, pp 34-48
- [10] Y. H. Kim, S-Y. Kang, M-L. Lee, B-G Yu, T. Zyung, "Optimization of Wireless Power Transmission through resonant coupling", in *compatibility and power Electronics*, 2009. CPE '09, May 2009, pp. 426-431

- [11] Tesla, N, "The transmission of electric energy without wires", The thirteenth Anniversary Number of the Electrical World and Engineering, March 1904, pp 234-241
- [12] Brown, W.C, "The History of Power Transmission by Radio waves", IEEE Trans. MIT, vol. 32, No. 9, 1984, pp 1230-1242
- [13] Glaser, P.E, "Power from the sun, science", No. 162, 1968, pp. 857-886
- [14] Matsumoto, H., "Microwave Power Transmission from Space and Related Non-linear Plasma Effects", The Radio Science Bulletin, NO. 273, 1995, pp. 11-35
- [15] Matsumoto, H. "Research on Solar Power Station and Microwave Power Transmission in Japan: Review and Perspectives", IEEE Microwave Magazine, Dec. 2002, pp. 36-45
- [16] Matsumoto, H, H. Hirata, Y. Hashino, and N. Shinohara, "Theoretical Analysis of Nonlinear Interaction of Intense Electromagnetic Wave and Plasma Waves in the Ionosphere", Electronics and communications in Japan, part 3, vol. 78, No. 11, 1995, pp. 10-11
- [17] Matsumoto, H, H. Hirata, Y. Hashino, and N. Shinohara, and Y. Omura, "Computer Simulation on Nonlinear Interaction of Intense Microwave with Space Plasmas", Electronics and Communications in Japan, part 3, vol. 78, No. 11, 1995, pp. 89-103
- [18] Schlesak, J.J, A. Alden and T. Ohno, "A microwave powered high altitude platform", IEEE MTT-s Int. Symp. Digest, 1988, pp. 283-286
- [19] Matsumoto, H., et al., "MILAX Airplane Experiment and Model Airplane," 12th ISAS Space Energy Symposium, Tokyo, Japan, March 1998
- [20] Shinohara N. and H. Matsumoto, "Dependence of DC output of a Rectenna Array on the Method of Interconnection of its Array Element", Electrical Engineering in Japan, vol. 125, No. 1, 1998, pp.9-17
- [21] N. Shinohara "Wireless Power Transmission for Solar Power Satellite(SPS), Space Solar Power Workshop, Georgia Institute of Technology, pp. 2

- [22] Mark Henley, Seth Potter, Joseph Howell, and John Mankins, "Wireless Power Transmission Options for Space Solar Power", IAC-02-R.4.08, pp. 10
- [23] S. Sheik Mohammed, K. Ramasamy, T. Shanmuganatham, "Wireless Power Transmission- A Next Generation Power Transmission System", International Journal of Computer Applications(0975-8887), Vol. 1- No. 13, 2010, pp.102
- [24] Nadar Engheta, "Metamaterials With Negative Permittivity and Permeability; Background, Salient Features, and New Trends", Department of Electrical & System Engineering, Departmental Papers(ESE), 2003, pp. 187.
- [25] D.R Smith, W. J. Padilla, D. C. Vier, S. C. Nemat, S. Schultz, "Composite Medium with Simultaneously Negative Permeability & Permeability", Physical Review Letters, Vol. 84, No.18, May 2000, pp. 4184-4187.
- [26] V. J. Logeeswaran, A. N. Stameroff, M. Saif Islam, W. Wu, A. M. Bratkovsky, P. J. Kuekes, S. Y. Wang, R. S. Williams, "Switching between Positive & Negative Permeability by Photoconductive Coupling for Modulation of Electromagnetic Radiative", Applied Physics A, Material Science & Processing. Vol. 87, March 2007, pp. 209-216.
- [27] J. B. Pendry, "Negative Refraction Makes a Perfect Lens", Physical Review Letters, Vol. 85, 2005, pp. 3966-3969.
- [28] A. K. Lyer, G. V. Eleftheriades, " Negative refractive Index Metamaterials Supporting 2-D Waves", IEEE MIT International Microwave Symposium(IMS), Seattle, June 2-7, 2002, pp. 1067-1070.
- [29] R. W. Ziolkowski, E. Heyman, "Wave Propagation in Media having Negative Permittivity and Permeability" Physical Review E. Vol. 64, No. 5, 2001.
- [30] R. A. Shelby, D. R. Smith, "Experimental Verification of a Negative Index of Refraction", Science, Vol. 292, No. 5514, April 2001, pp. 77-79.
- [31] I. V. Lindell, S. A. Tretyakov, K. I. Nikoskinen, S. Iivonen, "BW Media- Media with Negative Parameters, Capable of Supporting Backward Waves", Microwave and Optics Tech., Vol. 31, No. 2, Oct 2001, pp 129-133.