

# DESIGN AND CONSTRUCTION OF A DIGITAL THERMOMETER

OKE A. BABATOPE  
2005/22074EE

A PROJECT SUBMITTED TO THE DEPARTMENT  
OF ELECTRICAL AND COMPUTER  
ENGINEERING.

FEDERAL UNIVERSITY OF TECHNOLOGY  
MINNA, NIGER STATE.

NOVEMBER 2010

## **Dedication**

I dedicate this project work to the almighty God for his grace in my life.

## DECLARATION

I, Oke A. Babatope, declare that this work was done by me and has never been presented elsewhere for the award of a degree. I also hereby relinquish the copyright to the Federal University of Technology, Minna.

Oke A. Babatope

(Name of student)

  
17/11/10  
(Signature and date)

Mr. J. A. Ajiboye

(Name of Supervisor)

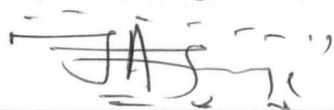
  
17/11/10  
(Signature and date)

Engr. A. G. Raji

(Name of Head of Department)

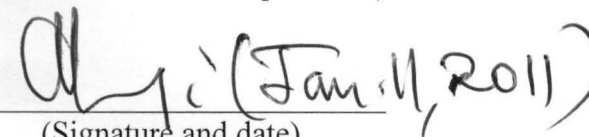
  
(Jan. 11, 2011)  
(Signature and date)

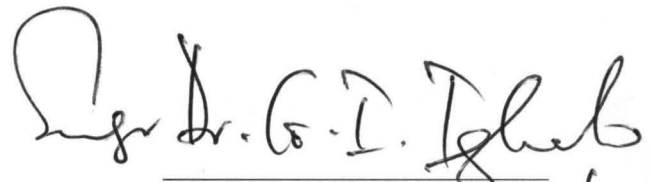

(Name of External Examiner)

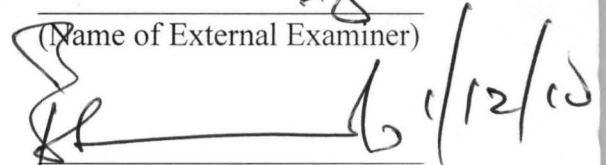
  
1/12/10  
(Signature and date)

## Acknowledgement

I wish to express my gratitude to Almighty God for making this work a success. I also wish to appreciate those who assisted me in one way or the other to make this work come to a reality. My special thanks go to my Supervisor Mr. J. A. Ajiboye who was of great inspiration to me, and my Technologist Mr. Bukky who was always there for me when I needed him. I also wish to appreciate my colleagues who were a challenge as well as a motivation to me, you guys made me to work extra miles, thanks.

My Heartfelt appreciation goes to my immediate family members; my Dad, Mum, Taye, and Dami, for their encouragement.



## **ABSTRACT**

A body temperature monitoring system includes a thermal detecting device, a converting device, processing device and a displaying device. The processing device reads a human body temperature detected by the thermal detecting device through the converting device, and then transmits a temperature signal to the displaying device. Thereby, monitoring of a patient's body temperature through the displaying device is possible. Besides, since the system is capable of displaying outward through the displaying device, the patient's abnormal body temperature can be reported so that proper treatment can be conducted timely.

## Table of content

Dedication	ii
Declaration	iii
Acknowledgement	iv
Abstract	v
Chapter One: Introduction	1
1.1 General introduction	1
1.2 Objectives of the project	2
1.3 Methodology	3
1.4 Scope and limitation	4
1.5 Thesis outline	4
Chapter Two: Literature review	5
2.1 Historical background	5
2.1.1 Temperature measurement in the early ages	5
2.1.2 Temperature measurement in the eighteenth century	6
2.1.3 Temperature measurement in the nineteenth century	6
2.1.4 Temperature measurement in the twentieth century	7
2.2 Theoretical background	7
2.2.1 Liquid in glass thermometer	7
2.2.2 Mercury in glass thermometer	8

2.2.3	Resistance thermometer	9
2.2.4	Thermo regulation	9
2.2.5	LM35 temperature sensor	10
2.2.6	Threshold (or set point)	12
2.2.7	Analog to digital converter(ADC0804)	12
2.2.8	Microcontollers versus microprocessor	14
2.2.9	The AT89C52 microcontroller	15
2.2.10	Liquid crystal display (LCD)	17
2.2.11	Power supply	20
2.2.12	Voltage regulator	21
2.3	Difficulties that limit performance	21
Chapter Three: Design and Implementation		22
3.1	Temperature detecting unit	25
3.2	Conversion Unit	25
3.3	Processor unit	26
3.3.1	AT89C52 pin description	27
3.3.2	Program	32
3.4	Control key unit	34
3.4.1	Reset button	34
3.4.2	Read button	34
3.5	Display unit	34
3.6	Power supply unit	35
3.6.1	Battery	36

3.6.2	7805CV voltage regulator	36
3.7	Calculation of limiting resistance $R_{LED}$	38
3.8	Calculation of ADC0804 clock frequency	39
3.9	Circuit implementation	40
Chapter four: Test, result and discussion		
4.1	Tests	42
4.1.1	Components test	42
4.1.2	Sensor test	42
4.1.3	General circuit test	42
4.2	Tools used	43
4.3	Photographic plates of the constructed work	44
4.4	Result and discussion	46
Chapter Five: Conclusion and Recommendation		
5.1	Conclusion	46
5.2	Problems encountered	46
5.3	Recommendation	46
Reference		48
Appendix I		48
Appendix II		50
Appendix III		51

## List of Figures

- g. 2.1 LM35 Full Range centigrade Temperature Sensor
- g. 2.2 ADC0804 Dual-In-Line and small Outline (SO) Packages
- g. 2.3 Block diagram of AT89C52
- g. 3.1 The block diagram of the system module
- g. 3.2 Circuit Diagram of ADC0804 and LM35 Connection
- g. 3.3 Diagram of AT89C52 microcontroller
- g. 3.4 Oscillator connection
- g. 3.5 Program flow chart
- g. 3.6 Diagram of LCD connected to the microcontroller
- g. 3.7 Voltage regulator
- g. 3.8 Diagram of LED Protected by a Limiting Resistor
- g. 3.9 Circuit diagram of the project

## List of Table

Table 2.1	Register Selection
Table 3.1	LM35 voltage output and ADC conversion
Table 3.2	Function of special features of AT89C52
Table 4.1	Voltage- temperature relationship of the sensor

# CHAPTER ONE

## 1.0 INTRODUCTION

### 1.1 GENERAL INTRODUCTION

Abnormal variation of human body temperature is often considered a warning of virus-incurred or bacterial infection and thus human body temperature is one of the important basis for identifying human physical disorder. In order to reduce mortality rates in Nigeria and the world at large, this project have been designed and constructed for use in various clinics and hospitals. This can be actualized using the normal body temperature of a human and the knowledge of microcontroller programming. This project is based on a microcontroller which uses a temperature sensor LM35 (an analog device), to measure the body temperature which is then converted to digital via an ADC0804 and further instructs the microcontroller AT89C52 to perform the appropriate programming instruction encoded in it. The program will constantly analyze the temperature reading and it is finally displayed on the LCD.

The cells of the body in warm-blooded animals operate most efficiently within a narrow range of temperature. In humans, body temperature is 37°C (98.6°F), although 36.4° and 37.2°C (97.5° and 99°F) are within normal limits [1]. If the body temperature goes below 33°C or above 40°C, it indicates an abnormal condition in the body (see appendix 1). Temperature measurement using body temperature monitoring device such as clinical thermometer (mercury and alcohol type) which is analogue in



nature are consider to be more reliable. The clinical thermometer is still in abundant supply and still the second most frequent test used to indicate the presence of an infection in the body by noting an elevation in the body temperature [2]. A more comprehensive one is the microcontroller clinical thermometer. Human body temperature are so important to the well being of warm blooded animals, that the nominal body temperature indicated by a clinical thermometer or similar device, is used as one of the vital signs routinely monitored as an indicator of a state of a person's or animal's health [2, 3].The need for an advanced electronic temperature monitoring device that can read the body temperature, display the temperature reading, and display the state or condition of the body at that temperature. Therefore the design and need of this project cannot be over emphasized which have been done in such a way that one can constantly check body temperature for early detection of any abnormality, so as to start early treatment in order to restore the body to its normal temperature.

## 1.2 OBJECTIVES OF THE PROJECT

One major aim of this project is to provide a portable body temperature monitoring device so as to save individuals, caregivers the labour consumed by repeatedly measuring and manually recording body temperature as required by the conventional devices.

The objectives of the project are as follows

- i. Measurement of Body Temperature.
- ii. Monitoring of Body Temperature.



- iii. Determination of Body Temperature variation with time.
- iv. Determination of Body Temperature at specific time of interest.

### 1.3 METHODOLOGY

The process is carried out by sticking the temperature sensor (LM35) to the body, then the power button is turned ON for the microcontroller to start reading the temperature of the patient, this process of temperature measurement in medicine is called axillary reading [1]. The temperature sensor (LM35) senses the temperature of the patient and generate an equivalent analog voltage that is directly proportional (linear) to the temperature. The analog voltage is independent of the power supply [4]. The analog voltage is then fed into the ADC0804 input pins for conversion to an 8-bit binary form, the output is then fed to an AT89C52 microcontroller which is further converted to decimal. The AT89C52 microcontroller already contain the temperature reading source codes written to it so that it can perform the received input from the output of the ADC0804, compare it with the threshold set point and display the corresponding temperature value and statement on the LCD. For this project the set point is between 30°C and below or 40°C and above. This process continues until the AT89C52 is turned OFF.

## 1.4 SCOPE AND LIMITATION

This project has been mainly designed for the purpose of measuring human body temperature in clinics, hospitals, and mainly for individuals to have. Its usage can also be found in the field of Veterinary medicine where it can be used to determine temperature of an animal whose body temperature is already known, so as to monitor its health status. However this project cannot be used for more than two species, this is because the two species have different body temperature and therefore must have different set point. However it is possible if the AT89C52 is reprogrammed. This is one advantage of using the AT89C52 microcontroller, it is reprogrammable.

## 1.5 THESIS OUTLINE

This thesis is set out to give an orderly account of what is contained and done in each chapter. It consists of five chapters.

Chapter 1 gives an insight into the project from an introductory point of view, presents the stated objectives of the project, methodology, scope and limitation of the project.

Chapter 2 gives a historical review of the project and also elucidates some fundamental components used in carrying out the project.

Chapter 3 shows the design and modular construction of the fragmented units which leads to the final completion of the project.

Chapter 4 gives the tests, results and discussion of the results.

Chapter 5 discloses the level of accomplishment of the task, problems encountered, and suggests future recommendations that could improve the device.

## **CHAPTER TWO**

### **2.0**

## **LITERATURE REVIEW**

### **2.1 HISTORICAL BACKGROUND**

The most measured parameter in the world so far is temperature, because of its importance and relevance biological and chemically to human life, as well as its diverse applications. The knowledge about temperature has been in existence for ages, the knowledge about temperature grew as man attempted to work with metal through the gold, silver, and bronze ages. Common sensors used for the measurement of temperature include resistance thermometer, thermostats, thermistor, and thermocouple.

#### **2.1.1 TEMPERATURE MEASUREMENT IN THE EARLY AGES**

Not until about 400 years ago, temperature measurement was based on assumption making it very subjective. In the early ages, numbers of much define points could be pointed at but it was rather impossible to measure the temperature between these points because there was no scale for measurement.

The first man to invent thermometer was Galileo Galilei (1564–1642) an Italian mathematician-physicist. In his instrument, built about 1592, the changing temperature of an inverted glass vessel produced an expansion or contraction of the air within it, which in turn changed the level of the liquid with which the vessel's long, openmouthed neck was partially filled. This general principle was perfected in succeeding years by experimenting with

liquids such as mercury and by providing a scale to measure the expansion and contraction brought about in such liquids by rising and falling temperatures [6].

### **2.1.2 TEMPERATURE MEASUREMENT IN THE EIGHTEENTH CENTURY**

By the early 18th century as many as 35 different temperature scales had been devised. The German physicist Daniel Gabriel Fahrenheit in 1700–30 produced accurate mercury thermometers calibrated to a standard scale that ranged from 32°, the melting point of ice, to 96° for body temperature. The unit of temperature (degree) on the Fahrenheit temperature scale is  $\frac{1}{180}$  of the difference between the boiling (212°) and freezing points of water. The first centigrade scale (made up of 100 degrees) is attributed to the Swedish astronomer Anders Celsius, who developed it in 1742. Celsius used 0° for the boiling point of water and 100° for the melting point of snow. This was later inverted to put 0° on the cold end and 100° on the hot end, and in that form it gained widespread use. It was known simply as the centigrade scale until in 1948 the name was changed to the Celsius temperature scale. In 1848 the British physicist William Thomson (later Lord Kelvin) proposed a system that used the degree Celsius but was keyed to absolute zero ( $-273.15\text{ }^{\circ}\text{C}$ ); the unit of this scale is now known as the Kelvin.

### **2.1.3 TEMPERATURE MEASUREMENT IN THE NINETEENTH CENTURY**

The measurement of temperature grew tremendously during the nineteenth century. A particular scientist Sir William Herschel, discovered that when sunlight was spread into a colour swath using a prism, he could detect an increase in temperature when moving a

blackened thermometer across the spectrum of colours. He later found out the effect of the heating increased beyond the red region called the "infrared". The radiation effects was measured from stores, candle fire and later concluded on the similarity of the radiation of heat and light.

Towards the end of the nineteenth century, there was introduction of the bimetallic temperature sensor. This thermometer contains no liquid but operate on the principle of unequal expansion between two metals. One metal that is bounded to another will bend towards one directon when heated and also bend in the opposite direction when cooled. Transmission of the bending motive occurred by a suitable mechanical linkage to a point that moves across a calibrated scale. Though this type of thermometer is not as accurate as liquid in glass, but the easier to handle and easy read.

#### **2.1.4 TEMPERATURE MEASUREMENT IN THE TWENTIETH CENTURY**

In the twentieth century, the discovery of semi-conducted devices such as thermostat, fiber optics temperature, integrated circuit sensor marked a great turn around improvement in the history of science. [7]

## **2.2 THEORETICAL BACKGROUND**

Accurate measurement of temperature depends on the establishment of thermal equilibrium between the thermometric device and its surroundings; that is, when at equilibrium no heat is exchanged between the thermometer and the material it touches or material in its vicinity. A clinical thermometer, therefore, must be inserted long enough



(more than one minute) to reach near-equilibrium with the human body to yield an accurate reading. It should also be inserted deep enough, and have sufficient contact with the body, to indicate temperature accurately. These conditions are almost impossible to achieve with an oral thermometer, which generally indicates a body temperature lower than that given by a rectal thermometer. Insertion times can be significantly reduced with small, rapidly reacting thermometers such as thermistor devices. [8]

Many different types of thermometers are in general use and many have been proposed. The following is a brief summary of the characteristics of common types of thermometers

### **2.2.1 LIQUID-IN-GLASS THERMOMETER**

This thermometer represents the oldest and perhaps most common practical thermometer. They come in the different forms and qualities with a variety of different liquids although mercury is the choice for accurate application. A very good thermometer uses up to 100°C and can be calibrated to 0.01°C. They are most useful for measurement of liquids.

The disadvantage of liquid-in-glass thermometer is that it is calibrated manually, a tedious process and must be read by the eye thereby may give error reading due to parallax with no opportunities for automated data acquisition.

### **2.2.2 MERCURY-IN-GLASS THERMOMETER**

Most of the thermometers used in the laboratory are based on the properties of expansion when heated. The volume of these substances assume various values at different temperatures. The most commonly used thermometer is the mercury-in-glass thermometer. This consists of a long uniform-bored capillary tube with a bulb at one end and closed at the

other. The bulb consists of mercury. When the bulb is heated, the mercury expands and rises into the capillary tube. The length of mercury column in the capillary tube is proportional to the temperature to which the bulb is subjected. This substance used in the construction of a thermometer is called a thermometric substance. In the case of mercury-in-glass thermometer, mercury is the thermometric substance. Alcohol is also widely used as a thermometric substance. While mercury freezes at  $-39^{\circ}\text{C}$ , alcohol freezes at  $-115^{\circ}\text{C}$ .

### 2.2.3 RESISTANCE THERMOMETER

Resistance thermometers are based on the increase in electrical resistance of conductors. Usually Platinum or alloy is used for the construction of such thermometer. Resistance thermometers are often used both for the control of temperature (as in a thermostat) and for the measurement of temperature.

### 2.2.4 THERMO REGULATION

The ability to keep and maintain a steady temperature is known as thermoregulation i.e. the maintenance of a steady body temperature regardless of changes in the environment. This process can be said to be an aspect of *homeostasis*: a dynamic state of equilibrium either metabolically within cell or organism or socially and psychologically within an individual's internal environment and its external environment. If the body is incapable of maintaining a steady temperature, it is either the body temperature increases significantly above normal a condition known as *heat stroke* or the opposite condition *hypothermia* occur, a condition when the body temperature decreases significantly below normal. As has been said above, the temperature of the body is kept nearly constant at  $98.6^{\circ}\text{F}$  ( $37^{\circ}\text{C}$ ). Fluctuations within a few tenths of a degree are perfectly compatible with health. Wider swings in temperature are

usually indicative of disease, and thus body temperature is an important factor in assessing health. Body temperature is regulated by a thermostatic control centre in the hypothalamus. A rise in body temperature initiates a chain of events leading to an increase in the rate of breathing and in sweating, two processes that serve to lower the body temperature. Similarly, a decrease in body temperature perhaps occasioned by a chilly winter walk, leads to increased heat-producing activity such as the muscular contractions of shivering.[9]

### **2.2.5 LM35 TEMPERATURE SENSOR**

#### **Description**

The LM35 series are precision integrated-circuit temperature sensors, whose output voltage is linearly proportional to the Celsius (Centigrade) temperature. The LM35 thus has an advantage over linear temperature sensors calibrated in ° Kelvin, as the user is not required to subtract a large constant voltage from its output to obtain convenient Centigrade scaling. The LM35 does not require any external calibration or trimming to provide typical accuracies of  $\pm 1/4^{\circ}\text{C}$  at room temperature and  $\pm 3/4^{\circ}\text{C}$  over a full  $-55$  to  $+150^{\circ}\text{C}$  temperature range. Low cost is assured by trimming and calibration at the wafer level. The LM35's low output impedance, linear output, and precise inherent calibration make interfacing to readout or control circuitry especially easy. It can be used with single power supplies, or with plus and minus supplies. As it draws only  $60\ \mu\text{A}$  from its supply, it has very low self-heating, less than  $0.1^{\circ}\text{C}$  in still air. The LM35 is rated to operate over a  $-55^{\circ}$  to  $+150^{\circ}\text{C}$  temperature range, while the LM35C is rated for a  $-40^{\circ}$  to  $+110^{\circ}\text{C}$  range ( $-10^{\circ}$  with improved accuracy) as shown in Fig 2.1. The LM35 series is available packaged in hermetic TO-46 transistor



packages, while the LM35C, LM35CA, and LM35D are also available in the plastic TO-92 transistor package. The LM35D is also available in an 8-lead surface mount small outline package and a plastic TO-220 package.

### Features

- Calibrated directly in ° Celsius (Centigrade)
- Linear + 10.0 mV/°C scale factor
- 0.5°C accuracy guaranteeable (at +25°C)
- Rated for full -55° to +150°C range remote applications
- Low cost due to wafer-level trimming
- Operates from 4 to 30 volts
- Less than 60  $\mu$ A current drain
- Low self-heating, 0.08°C in still air
- Nonlinearity only  $\pm 1/4$ °C typical
- Low impedance output, 0.1 Ohm for 1 mA load

## Typical Applications

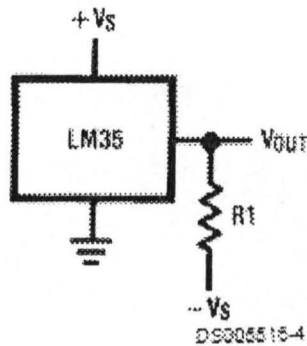

Fig 2.1 LM35 Full-Range Centigrade Temperature Sensor

Choose  $R1 = -V_S/50 \mu A$

$V_{out} = +1,500 \text{ mV at } +150^\circ\text{C}$

$= +250 \text{ mV at } +25^\circ\text{C}$

$= -550 \text{ mV at } -55^\circ\text{C}$

### 2.2.6 THRESHOLD (OR SET POINT)

This is the temperature range set by the microcontroller program for the ADC0804 to start converting the LM35 output. The set point for this particular project has been set to be from  $25^\circ\text{C}$  to  $45^\circ\text{C}$

### 2.2.7 ANALOG TO DIGITAL CONVERTER (ADC0804)

Since the only language the microcontroller understand is the binary numbers (i.e. 1 and 0) there is need to use the analog to digital converter that will convert the output of the

temperature sensor (analog in nature) to binary which can be comprehended by a microcontroller. This task in this project is done by an ADC0804. The diagram is shown in Fig 2.2

### **General Description**

The ADC0804 is a CMOS 8-bit successive approximation A/D converter that uses a differential potentiometric ladder-similar to the 256R products. These converters are designed to allow operation with the NSC800 and INS8080A derivative control bus with TRI-STATE output latches directly driving the data bus. These A/Ds appear like memory locations or I/O ports to the microprocessor and no interfacing logic is needed. Differential analog voltage inputs allow increasing the common-mode rejection and offsetting the analog zero input voltage value. In addition, the voltage reference input can be adjusted to allow encoding any smaller analog voltage span to the full 8 bits of resolution.

### **Features**

- Compatible with 8080  $\mu$ P derivatives—no interfacing logic needed - access time - 135 ns
- Easy interface to all microprocessors, or operates “stand alone”
- Differential analog voltage inputs
- Logic inputs and outputs meet both MOS and TTL voltage level specifications
- Works with 2.5V (LM336) voltage reference
- On-chip clock generator

- 0V to 5V analog input voltage range with single 5V supply
- No zero adjust required
- 0.3" standard width 20-pin DIP package
- 20-pin molded chip carrier or small outline package
- Operates ratio-metrically or with 5 VDC, 2.5 VDC, or analog span adjusted voltage reference

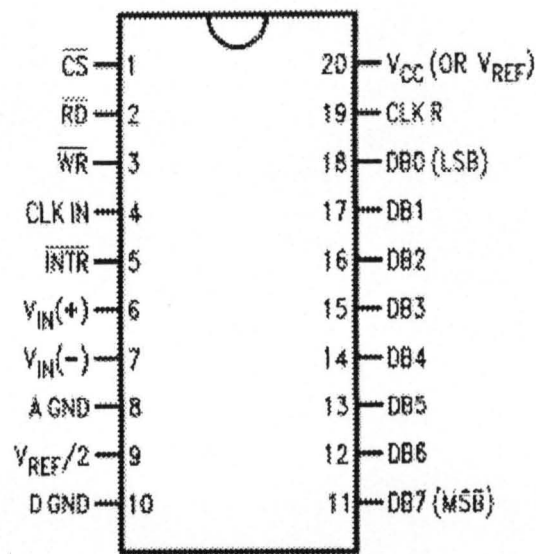

Fig 2.2 ADC0804 Dual-In-Line and small Outline (SO) Packages

### 2.2.8 MICROCONTROLLERS VERSUS MICROPROCESSORS

Microcontroller differs from a microprocessor in terms of its design and most importantly in its functionality. A microprocessor is not a complete computer. It does not contain large amounts of memory or have the ability to communicate with input devices—such as keyboards, joysticks, and mice—or with output devices, such as monitors and printers. A

different kind of integrated circuit, a microcontroller, is a complete computer on a chip, containing all of the elements of the basic microprocessor along with other specialized functions. Microcontrollers are used in video games, videocassette recorders (VCRs), automobiles, and other machines [10].

## 2.2.9 THE AT89C52 MICROCONTRLLER

### Description

The AT89C52 is a low-power, high-performance CMOS 8-bit microcomputer with 8K bytes of Flash programmable and erasable read only memory (PEROM). The device is manufactured using Atmel's high-density nonvolatile memory technology and is compatible with the industry standard 80C51 and 80C52 instruction set and pinout. The on-chip Flash allows the program memory to be reprogrammed in-system or by a conventional nonvolatile memory programmer. By combining a versatile 8-bit CPU with Flash on a monolithic chip, the Atmel AT89C52 is a powerful microcomputer which provides a highly-flexible and cost-effective solution to many embedded control applications. The block diagram of an AT89C52 is shown in Fig 2.3

### Features

- Compatible with MCS-51™ Products
- 8K Bytes of In-System Reprogrammable Flash Memory
- Endurance: 1,000 Write/Erase Cycles
- Fully Static Operation: 0 Hz to 24 MHz
- Three-level Program Memory Lock

- 256 x 8-bit Internal RAM
- 32 Programmable I/O Lines
- Three 16-bit Timer/Counters
- Eight Interrupt Sources
- Programmable Serial Channel
- Low-power Idle and Power-down Modes

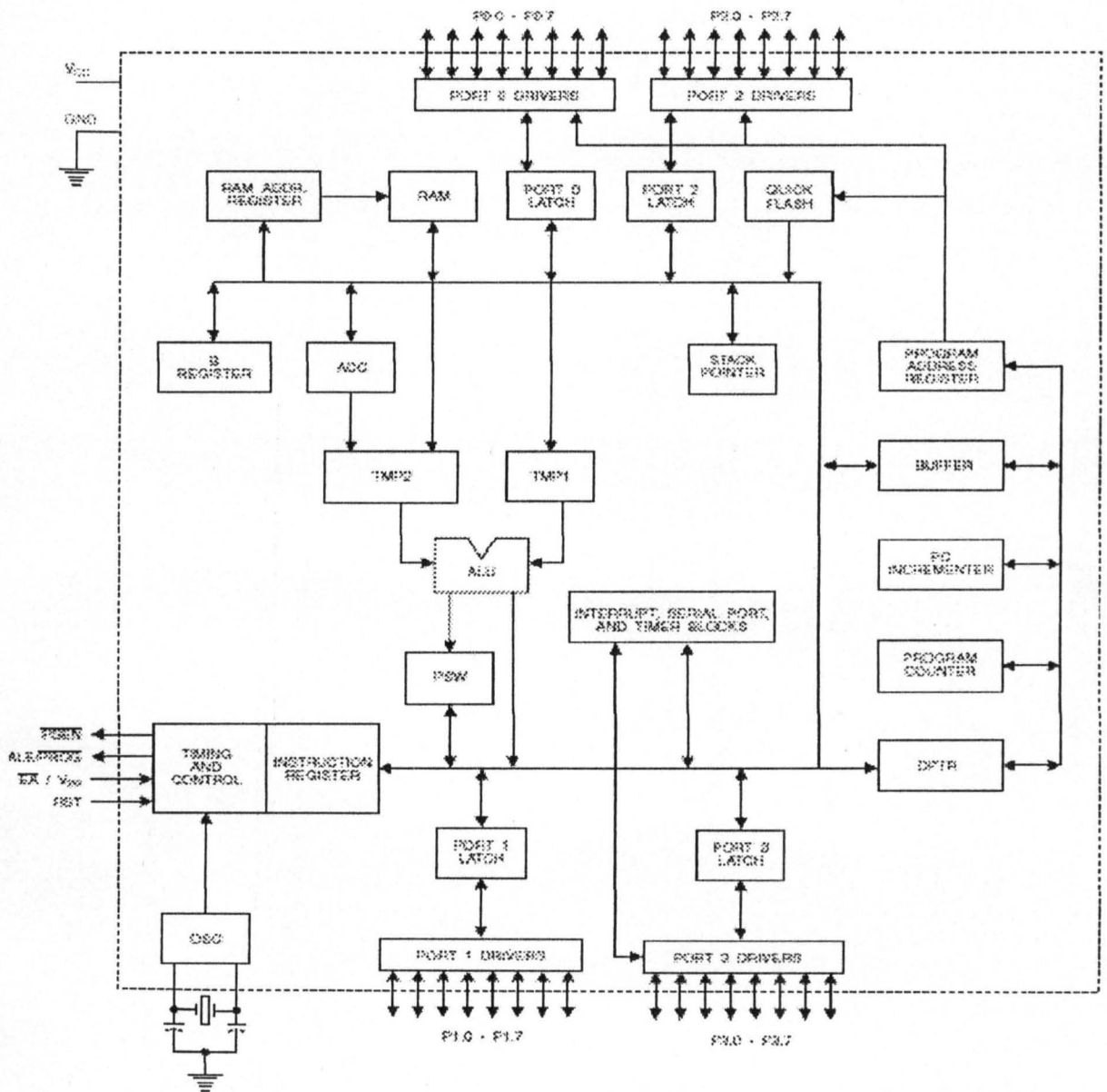

Figs 2.3 Block diagram of AT89C52

### 2.2.10 LIQUID CYRSTAL DISPLAY-LCD (HD44780U)

This is a logic oriented Liquid Crystal Display (LCD). It is a 16 character by 2 line alphanumeric LCD assembly with embedded controller. It accepts binary codes from a



microcontroller/microprocessor through the data input pins and display it on the screen according to the configuration. It can be configured to operate in 4- or 8-bit mode with supply voltage (V<sub>ss</sub>) at +5V.

### **General Description**

The HD44780U dot-matrix liquid crystal display controller and driver LSI displays alphanumeric, Japanese kana characters, and symbols. It can be configured to drive a dot-matrix liquid crystal display under the control of a 4- or 8-bit microprocessor. Since all the functions such as display RAM, character generator, and liquid crystal driver, required for driving a dot-matrix liquid crystal display are internally provided on one chip, a minimal system can be interfaced with this controller/driver. A single HD44780U can display up to one 8-character line or two 8-character lines. The HD44780U has pin function compatibility with the HD44780S which allows the user to easily replace an LCD-II with an HD44780U. The HD44780U character generator ROM is extended to generate 208 5 x 8 dot character fonts and 32 5 x 10 dot character fonts for a total of 240 different character fonts. The low power supply (2.7V to 5.5V) of the HD44780U is suitable for any portable battery-driven product requiring low power dissipation.

### **Function Description**

#### **Registers**

The HD44780U has two 8-bit registers, an instruction register (IR) and a data register (DR). The IR stores instruction codes, such as display clear and cursor shift, and address information for display data RAM (DDRAM) and character generator RAM (CGRAM). The



IR can only be written from the MPU. The DR temporarily stores data to be written into DDRAM or CGRAM and temporarily stores data to be read from DDRAM or CGRAM. Data written into the DR from the MPU is automatically written into DDRAM or CGRAM by an internal operation. The DR is also used for data storage when reading data from DDRAM or CGRAM. When address information is written into the IR, data is read and then stored into the DR from DDRAM or CGRAM by an internal operation. Data transfer between the MPU is then completed when the MPU reads the DR. After the read, data in DDRAM or CGRAM at the next address is sent to the DR for the next read from the MPU. By the register selector (RS) signal, these two registers can be selected (Table 2.0).

#### **Busy Flag (BF)**

When the busy flag is 1, the HD44780U is in the internal operation mode, and the next instruction will not be accepted. When  $RS = 0$  and  $R/W = 1$  (Table 2.0), the busy flag is output to DB7. The next instruction must be written after ensuring that the busy flag is 0.

#### **Address Counter (AC)**

The address counter (AC) assigns addresses to both DDRAM and CGRAM. When an address of an instruction is written into the IR, the address information is sent from the IR to the AC. Selection of either DDRAM or CGRAM is also determined concurrently by the instruction.

After writing into (reading from) DDRAM or CGRAM, the AC is automatically incremented by 1 (decremented by 1). The AC contents are then output to DB0 to DB6 when  $RS = 0$  and  $R/W = 1$  (Table 2.1).

Table 2.1 Register Selection

RS	R/W	OPERATION
0	0	IR write as an internal operation (display clear, etc.)
0	1	Read busy flag(DB7) and address counter (DB0 to DB6)
1	0	DR write as an internal operation (DR to DDRAM or CGRAM)
1	1	DR read as an internal operation (DDRAM or CGRAM to DR)

### Display Data RAM (DDRAM)

Display data RAM (DDRAM) stores display data represented in 8-bit character codes. Its extended capacity is 80 x 8 bits, or 80 characters. The area in display data RAM (DDRAM) that is not used for display can be used as general data RAM.

### Character Generator RAM (CGRAM)

In the character generator RAM, the user can rewrite character patterns by program. For 5 x 8 dots, eight character patterns can be written, and for 5 x 10 dots, four character patterns can be written.

### 2.2.11 POWER SUPPLY

The power supply used in this project is a 9V battery (Leclanche cell). The battery has the ability to supply the entire system with a constant voltage, for a considerably period of time before running down; approximately about three months since the whole system consume less power.

### **Advantage of using Leclanche Cell over other forms of power**

- It is not bulky, hence it is convenient in making portable project
- It is replaceable
- In of power failure it is a better alternative

However the main disadvantage of using it is its susceptibility to chemical leakage and polarization which can cause damage to the component in the circuit.

### **2.2.12 VOLTAGE REGULATOR**

The voltage regulator used for the actualization of this project is the L7805CV. Its major function is to regulate 9V power supply to 5V which is used to power the whole circuit.

#### **L7805CV Voltage Regulator**

The L7800 series of three-terminal positive regulators is available in TO-220, TO-220FP, TO-220FM, TO-3 and D2PAK packages and several fixed output voltages, making it useful in a wide range of application. These regulators can local on-card regulation, eliminating the distribution problems associated with single point regulation. Each type employs internal current limiting, thermal shut-down and safe are a protection, making it essentially indestructible. If adequate heat sinking is provided, they can deliver over 1A output current. Although designed primarily as fixed voltage regulator, these devices can be used with external components to obtain adjustable voltage and current. These devices have the following features for which it was choosing for this project

- Output voltage of 5, 5.2, 6, 8, 8.5, 9, 10, 12, 15, 18, 24V
- Output current to 1.5A
- Short circuit protection
- Thermal overload protection
- Output transition SOA protection

### **2.3 DIFFICULTIES THAT LIMIT PERFORMANCE**

The difficulties that limit performance of this project is solely from the fact that the temperature monitoring device will not give accurate measurement or else there is a thermal balance between the temperature sensor and the patient body. To attain thermal balance, it usually takes up to one to two minutes; hence, the quickness of temperature reading has a maximum delay of before an accuracy of  $0.1^{\circ}\text{C}$  for 10ml volt conversion to be attained. Although, the power loss of the circuit is minimal, its major effect cannot be overruled.

## CHAPTER THREE

### 3.0 DESIGN AND IMPLEMENTATION

According to this project the body temperature monitoring device comprises a temperature detecting unit a converting unit, a processor unit, a display unit, a control key unit and a power supply unit. The temperature detecting unit includes a temperature sensitive element adapted to be placed in contact with a human body part so as to generate an analogue voltage output corresponding to the temperature sensed by the temperature sensitive element. The conversion unit converts the analogue voltage output of the temperature detecting unit to binary code. The processor unit is connected to the conversion unit, the display unit and the control key unit. The control key unit is operable so as to control the processing unit to fetch temperature information corresponding to the digital temperature signal from the conversion unit. The control key unit is further operable so as to control the processor unit to convert binary code to decimal so as to enable the processor unit to control the display unit to show the temperature information in decimal and the stored information for each temperature. The integrated assembly of the system that finally lead to the accomplishment of the assembly are as listed in the following order:

- Temperature detecting unit
- Conversion unit
- Processor unit

- Control unit
- Display unit
- Power supply unit

The block diagram of the system module is shown in fig 3.1

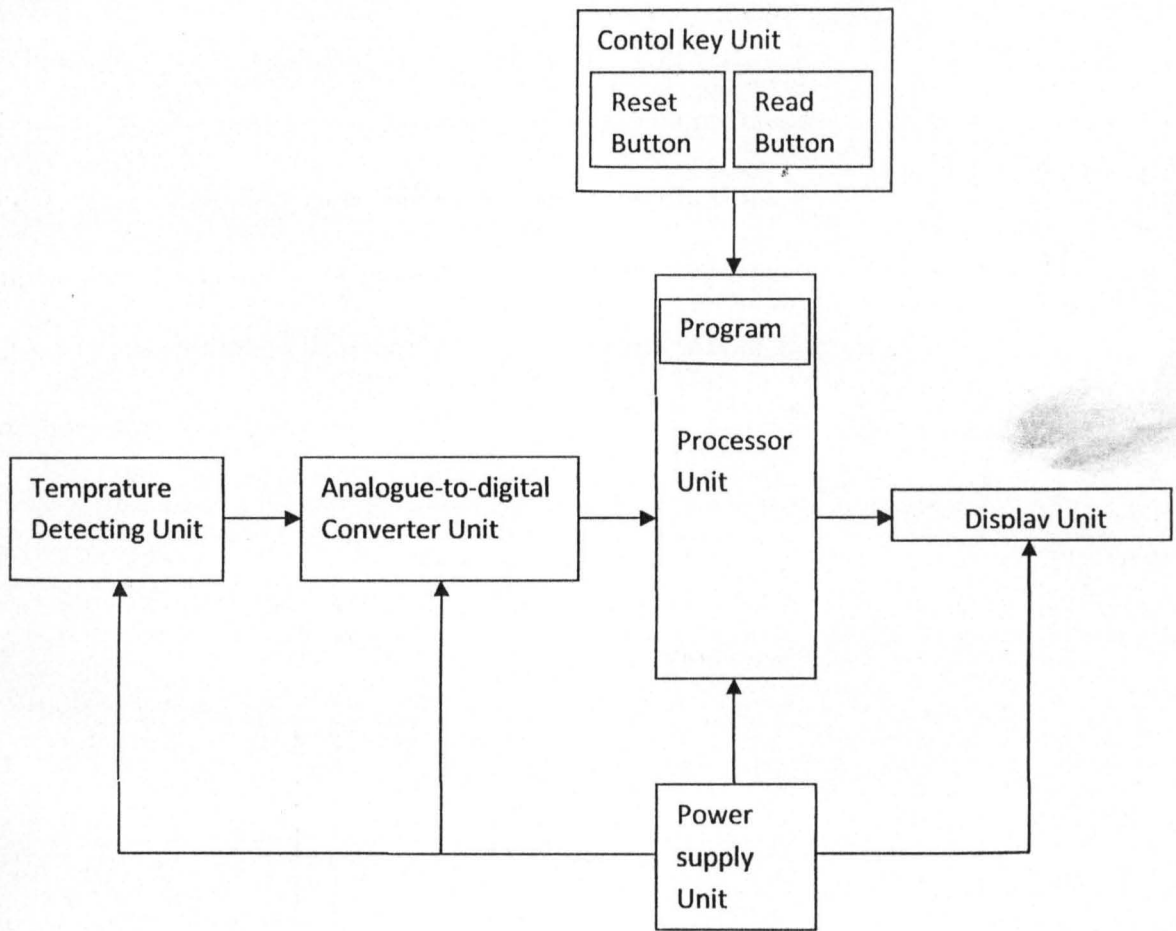

Fig 3.1 Schematic Circuit Block Diagram of the System Module



### 3.1 TEMPERATURE DETECTING UNIT

In this unit the temperature sensitive element is a LM35. A body contact pad has the temperature sensitive element mounted on it and is to be attached releasably on a human body part. The LM35 Temperature sensor was chosen for this project design due to the advantageous features it has over other temperature sensors already mentioned in article 2.2.2.

The LM35 output is 10mV per degree Celsius, that is to say for every 1°C increase, there is an increase by 10mV in the output of the temperature sensor.

### 3.2 CONVERSION UNIT

The analog-to-digital converter is connected electrically to the temperature sensitive element by an electric cable, and to the processor unit so as to generate a digital temperature signal corresponding to temperature sensed by the temperature sensitive element. The conversion of the analog voltages to binary codes are stated below

Table 3.1 LM35 voltage output and ADC conversion.

LM35 Output (mV)	ADC Conversion
25	00011001
26	00011010
27	00011011
28	00011100

29	00011101
30	00011110
31	00011111
32	00100000
33	00100001
34	00100010
35	00100011
36	00100100
37	00100101
38	00100110
39	00100111
40	00101000
41	00101001
43	00101011
44	00101100
45	00101101



The ADC0804 and LM35 Connection is shown in fig 3.2

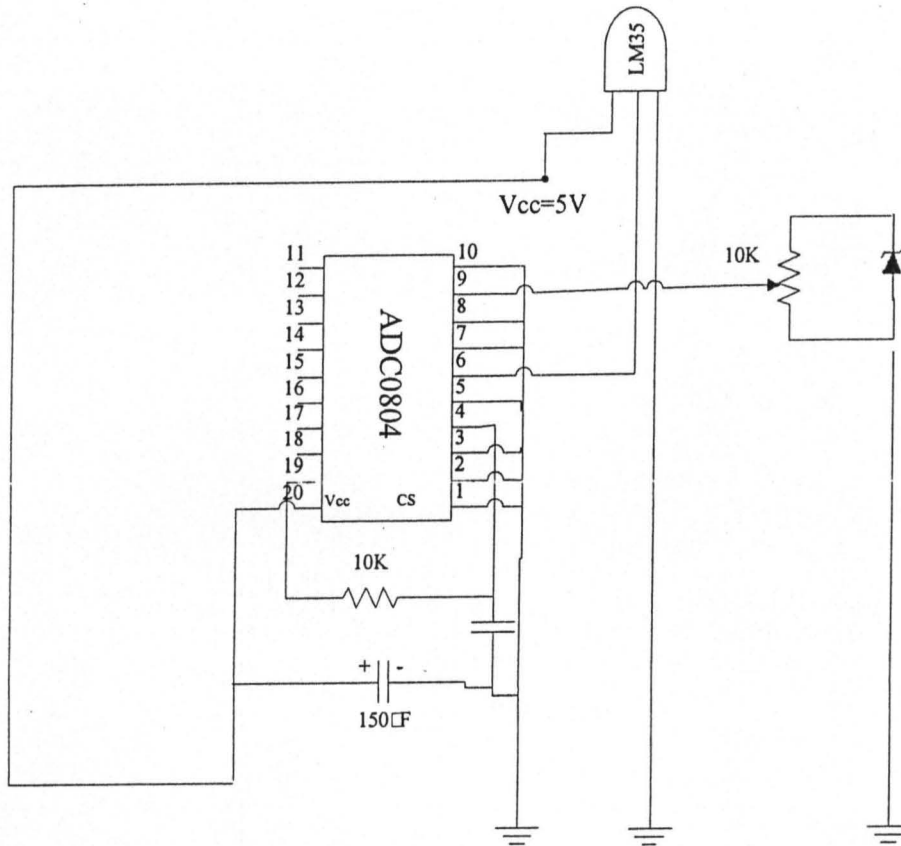

Fig 3.2 Circuit Diagram of ADC0804 and LM35 Connection

### 3.3 PROCESSOR UNIT

This unit consists of the AT89C52 microcontroller. The design of the microcontroller is driven by the desire to make it as expandable and flexible as possible. In a microcontroller, all the necessary peripherals are built into it i.e it have an on chip RAM and ROM (EPROM) in addition to on chip I/O hard ware so as to minimize chip count in single chip solutions. The main use of the microcontroller is to control the operation of the system using

a fixed program that is stored in the ROM and does not change over the lifetime of the system. The microcontroller gets its data from its own pins. The description of this pins are shown in fig 3.3.

### 3.3.1 AT89C52 PIN DESCRIPTION

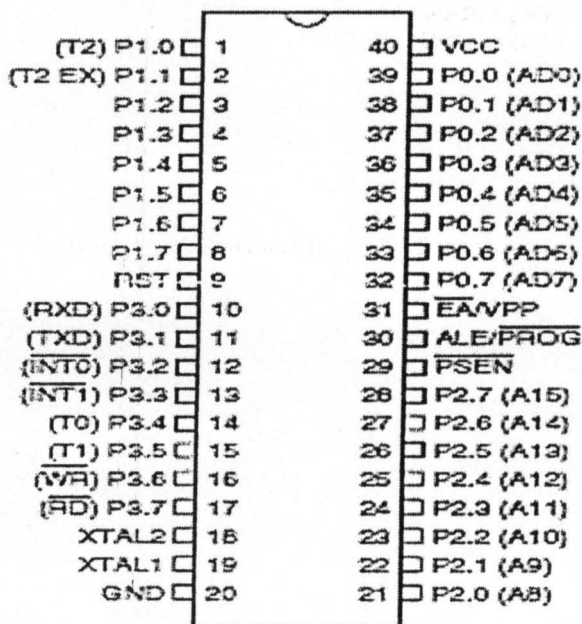

Fig 3.3 Diagram of AT89C52 microcontroller

Vcc – Supply voltage

GND – Ground

Port 0

Port 0 is an 8-bit open drain bi-directional I/O port. As an output port, each pin can sink eight TTL inputs. When 1s are written to port 0 pins, the pins can be used as an highimpedance inputs. Port 0 can also be configured to be the multiplexed loworder

address/data bus during accesses to external program and data memory. In this mode, P0 has internal pullups. Port 0 also receives the code bytes during Flash programming and outputs the code bytes during program verification. External pullups are required during program verification.

### **Port 1**

Port 1 is an 8-bit bi-directional I/O port with internal pullups. The Port 1 output buffers can sink/source four TTL inputs. When 1s are written to Port 1 pins, they are pulled high by the internal pullups and can be used as inputs. As inputs, Port 1 pins that are externally being pulled low will source current (IIL) because of the internal pullups. In addition, P1.0 and P1.1 can be configured to be the timer/counter 2 external count input (P1.0/T2) and the timer/counter 2 trigger input (P1.1/T2EX), respectively, as shown in the following table. Port 1 also receives the low-order address bytes during Flash programming and verification.

### **Port 2**

Port 2 is an 8-bit bi-directional I/O port with internal pullups. The Port 2 output buffers can sink/source four TTL inputs. When 1s are written to Port 2 pins, they are pulled high by the internal pullups and can be used as inputs. As inputs, Port 2 pins that are externally being pulled low will source current (IIL) because of the internal pullups. Port 2 emits the high-order address byte during fetches from external program memory and during accesses to external data memory that uses 16-bit addresses (MOVX @ DPTR). In this application, Port 2 uses strong internal pullups when emitting 1s. During accesses to external data memory that uses 8-bit addresses (MOVX @ RI), Port 2 emits the contents of the P2

Special Function Register. Port 2 also receives the high-order address bits and some control signals during Flash programming and verification.

### Port 3

Port 3 is an 8-bit bi-directional I/O port with internal pullups. The Port 3 output buffers can sink/source four TTL inputs. When 1s are written to Port 3 pins, they are pulled high by the internal pullups and can be used as inputs. As inputs, Port 3 pins that are externally being pulled low will source current (IIL) because of the pullups. Port 3 also receives some control signals for Flash programming and verification. Port 3 also serves the functions of various special features of the AT89C52, as shown in the table.

Table 3.2: Function of special features of AT89C52

Port Pin	Alternate Functions
P3.0	RXD(serial input port)
P3.1	TXD(serial output port)
P3.2	INT0(external interrupt 0)
P3.3	INT1(external interrupt 1 )
P3.4	T0 (timer 0 external input)
P3.5	T1 (timer 1 external input)
P3.6	WR (external data memory write strobe)
P3.7	RD (external data memory read strobe)

## RST

Reset input. A high on this pin for two machine cycles while the oscillator is running resets the device.

## XTAL1

Input to the inverting oscillator amplifier and input to the internal clock operating circuit.

## XTAL2

Output from the inverting oscillator amplifier

### Oscillator Characteristics

XTAL1 and XTAL2 are the input and output, respectively, of an inverting amplifier that can be configured for use as an on-chip oscillator, as shown in Figure 7. Either a quartz crystal or ceramic resonator may be used. To drive the device from an external clock source, XTAL2 should be left unconnected while XTAL1 is driven, as shown in Figure 8. There are no requirements on the duty cycle of the external clock signal, since the input to the internal clocking circuitry is through a divide-by-two flip-flop, but minimum and maximum voltage high and low time specifications must be observed.

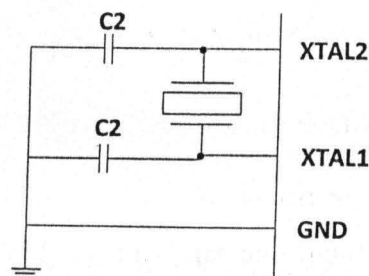

Figure 3.4 Oscilalator connection

### **$\overline{\text{PSEN}}$**

Program Store Enable is the read strobe to external program memory. When the AT89C52 is executing code from external program memory, PSEN is activated twice each machine cycle, except that two PSEN activations are skipped during each access to external data memory.

### **$\text{ALE}/\overline{\text{PROG}}$**

Address Latch Enable is an output pulse for latching the low byte of the address during accesses to external memory. This pin is also the program pulse input (PROG) during Flash programming. In normal operation, ALE is emitted at a constant rate of 1/6 the oscillator frequency and may be used for external timing or clocking purposes. Note, however, that one ALE pulse is skipped during each access to external data memory. If desired, ALE operation can be disabled by setting bit 0 of SFR location 8EH. With the bit set, ALE is active only during a MOVX or MOVC instruction. Otherwise, the pin is weakly pulled high. Setting the ALE-disable bit has no effect if the microcontroller is in external execution mode.

### **$\overline{\text{EA}}/\text{VPP}$**

External Access Enable. EA must be strapped to GND in order to enable the device to fetch code from external program memory locations starting at 0000H up to FFFFH. Note, however, that if lock bit 1 is programmed, EA will be internally latched on reset. EA should be strapped to VCC for internal program executions. This pin also receives the 12-volt



programming enable voltage (VPP) during Flash programming when 12-volt programming is selected.

### **Idle Mode**

In idle mode, the CPU puts itself to sleep while all the onchip peripherals remain active. The mode is invoked by software. The content of the on-chip RAM and all the special functions registers remain unchanged during this mode. The idle mode can be terminated by any enabled interrupt or by a hardware reset. Note that when idle mode is terminated by a hardware reset, the device normally resumes program execution from where it left off, up to two machine cycles before the internal reset algorithm takes control. On-chip hardware inhibits access to internal RAM in this event, but access to the port pins is not inhibited. To eliminate the possibility of an unexpected write to a port pin when idle mode is terminated by a reset, the instruction following the one that invokes idle mode should not write to a port pin or to external memory.

### **3.3.2 PROGRAM**

Basically the source code was written in assembly language. It is this source code that is use to program the microcontrollerto actualize the project. The source code was assembled using the KIEL micro version assembler (see appendix III). The AT89C52 microcontroller is a lifeless chip without this programme. In this project, it is programmed to measure human body temperature. The flow chat for the program is shown in fig 3.5



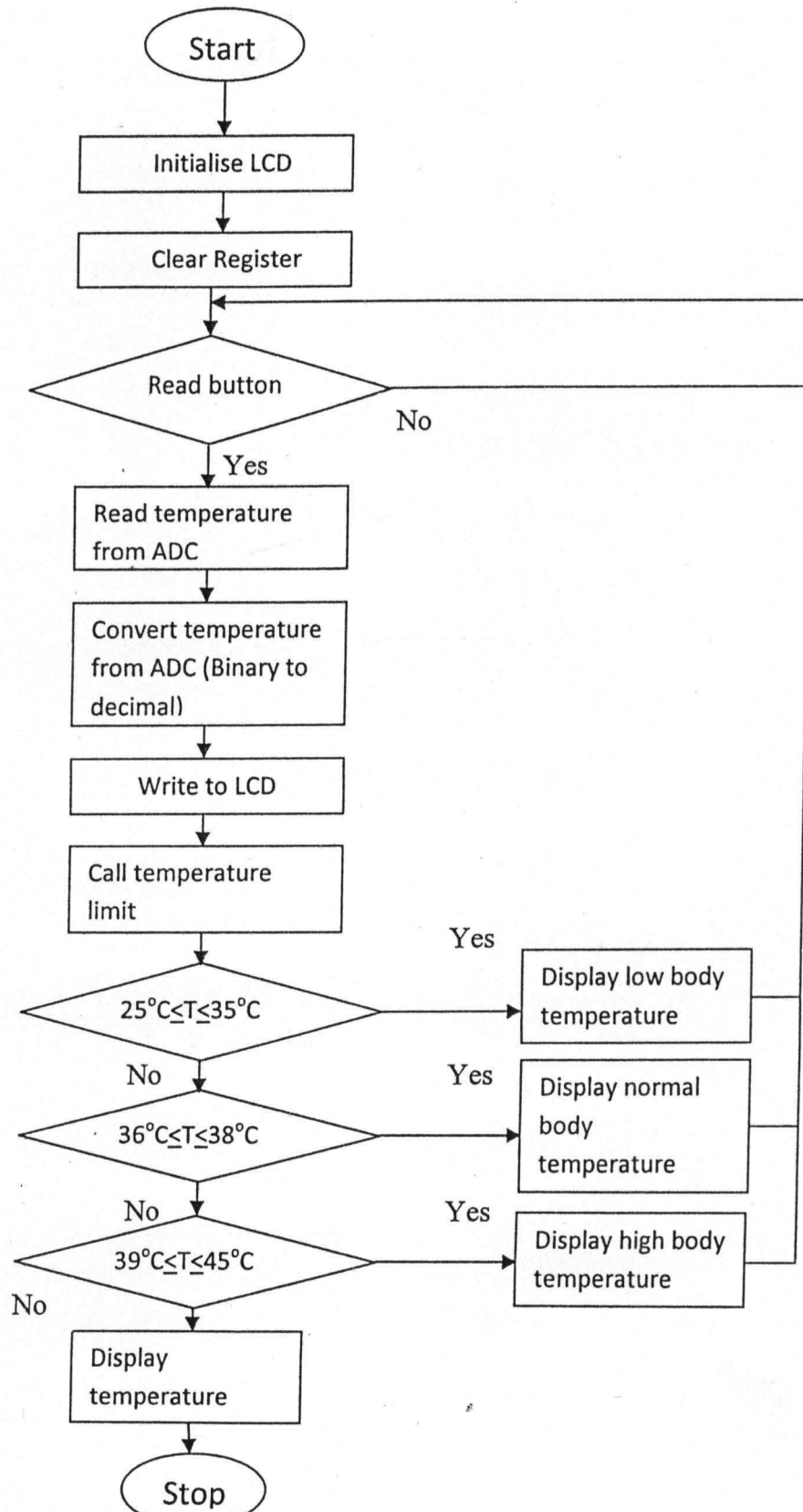

Fig 3.5 Program flow chart

### **3.4 CONTROL KEY UNIT**

This unit consist of the reset button and the read button

#### **3.4.1 RESET BUTTON**

This button is operable so as to reset the processor unit to its initial state.

#### **3.4.2 READ BUTTON**

This button is applicable so as to read and display the body temperature in the temperature detecting unit.

This button controls the processor unit to read temperature information from the analogue to digital converter (ADC0804) and also enables the processor unit to send to the display unit the temperature value and the store information attached to it.

### **3.5 DISPLAY UNIT**

The display unit consists of the LCD which display on screen, the body temperature information from the processor unit. The LCD is connected to port 1 of the microcontroller as shown in fig 3.6.

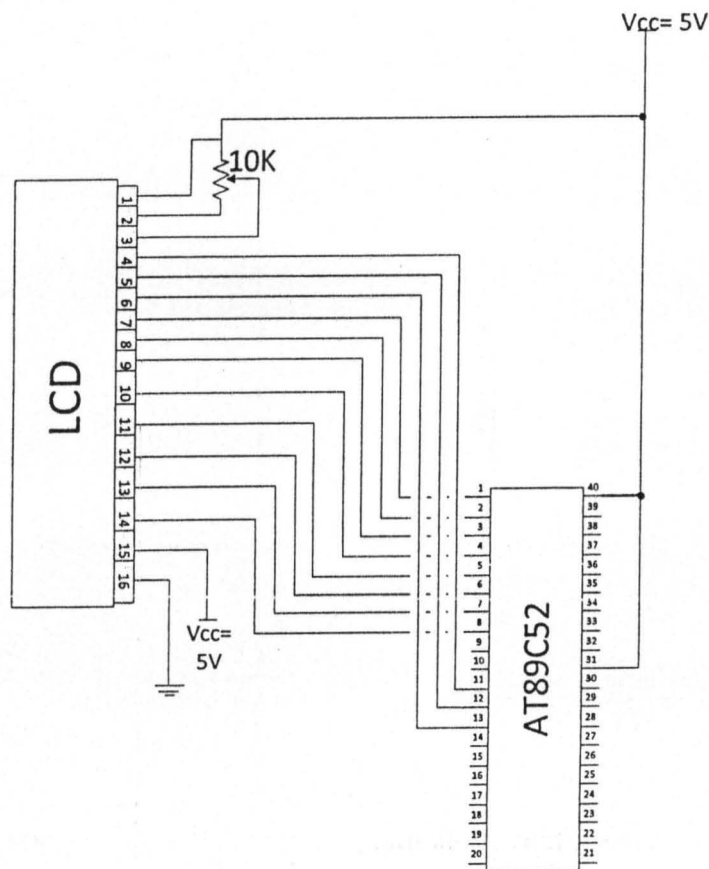

Fig 3.6 Diagram of LCD connected to the microcontroller

### 3.6 POWER SUPPLY UNIT

The power supply used in this project is aim at providing a stable and free of noise or interference which can damage the components and also modify the programme. Also this project is design to operate with a DC power supply of 5V. Hence taking this into consideration, the most convinient and reliable DC power supply is a 9V battery

### 3.6.1 BATTERY

It is a device that converts chemical energy into electricity. Strictly speaking, a battery consists of two or more cells connected in series or parallel, but the term is also used for single cells. All cells consist of a liquid, paste, or solid electrolyte and a positive electrode, and a negative electrode. The electrolyte is an ionic conductor; one of the electrodes will react, producing electrons, while the other will accept electrons. When the electrodes are connected to a device to be powered, called a load, an electrical current flows.

### 3.6.2 7805CV VOLTAGE REGULATOR

The 7800 series of IC regulator is a representative of three terminal devices that are available with several fixed positive output voltages making them useful in wide range of application. It has three terminal labelled input ( $V_{in}$ ), output ( $V_{out}$ ), and ground (GND).

The voltage regulator is an integrated circuit that is capable of maintaining a constant dc output voltage irrespective of variations of the ac input voltage and output load resistance.

The voltage regulator used in this design is the L7805CV regulator which is a 3 pins integrated circuit having an input, common and regulated output terminals. The 7805 voltage regulator is shown in Fig. 3.7.

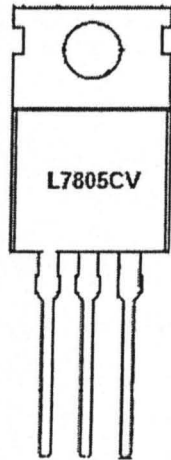

Fig.3.7: Voltage Regulator.

This voltage regulator provides a constant 5V dc supply at its output terminals which is more efficient to drive the infrared receiver circuit than a non-regulated supply. The voltage regulators of this class (78XX) require an input voltage that must be at least 2V above the output voltage [11].

### 3.7 CALCULATION OF LIMITING RESISTANCE $R_{LED}$ FOR LED.

The LED was protected by a limiting resistor  $R_S$  connected as shown by Fig. 3.9.

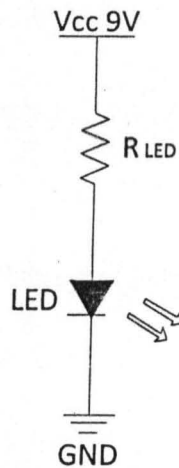

Fig. 3.8: Diagram of LED Protected by a Limiting Resistor.

We know that in a series circuit,

Voltage across the circuit = sum of voltages across each component of the circuit

$$\begin{aligned} V_S &= V_R + V_{LED} \\ &= I_{LED} R_S + V_{LED} \end{aligned}$$

But

$$V_S = 9V$$

A voltage of 1.7V across the LED and maximum current of 15mA to flow through it were chosen.

$$9 = 15 \times 10^{-3} \times R_s + 1.7$$

$$\begin{aligned} R_s &= \frac{9 - 1.7}{15.5 \times 10^{-3}} \\ &= 470.9 \Omega \\ &= 471 \Omega \end{aligned}$$

Therefore a resistor of 470Ω is used since it has a tolerance of 10%

Resistor  $R_{LED}$  ensures long life of the LED by ensuring it is operated on a current of magnitude less than the LED's maximum rating.

### 3.8 CALCULATION OF ADC0804 CLOCK FREQUENCY.

CLK IN is an input pin connected to an external clock source. To use the internal clock generator (also called self-clocking), CLK IN and CLK R pins are connected to a capacitor and a resistor, and the clock frequency is determined by

$$f = \frac{1}{1.1RC}$$

Typical values are  $R = 10K$  ohms and  $C = 150$  pF

We get  $f = 606$  kHz and the conversion time is 110 μs

To calculate the output voltage, we use

$$D_{out} = \frac{V_{in}}{\text{step size}}$$

$D_{out}$  = digital data output (in decimal),

$V_{in}$  = analog voltage, and

Step size (resolution) is the smallest change (see appendix II).



### 3.9 CIRCUIT IMPLEMENTATION

The implementation of this circuit is concluded from the assembly of the different modules as elucidated in article 3.1 to 3.8 of this chapter. The circuit constitutes of the Vin and GND of the LM35 temperature sensor connected to the 7805 IC Vout and GND respectively. Vout of the LM35 is connected to pin 6 of the ADC0804. The ADC0804 is in turn connected to port 2 of the AT89C52 microcontroller. The Vcc of the microcontroller is connected to the Vout of the 7805 IC and the Vss is connected to the ground. The LCD is connected to port 1 of the microcontroller. A detailed circuit diagram is as shown in Fig 3.9.

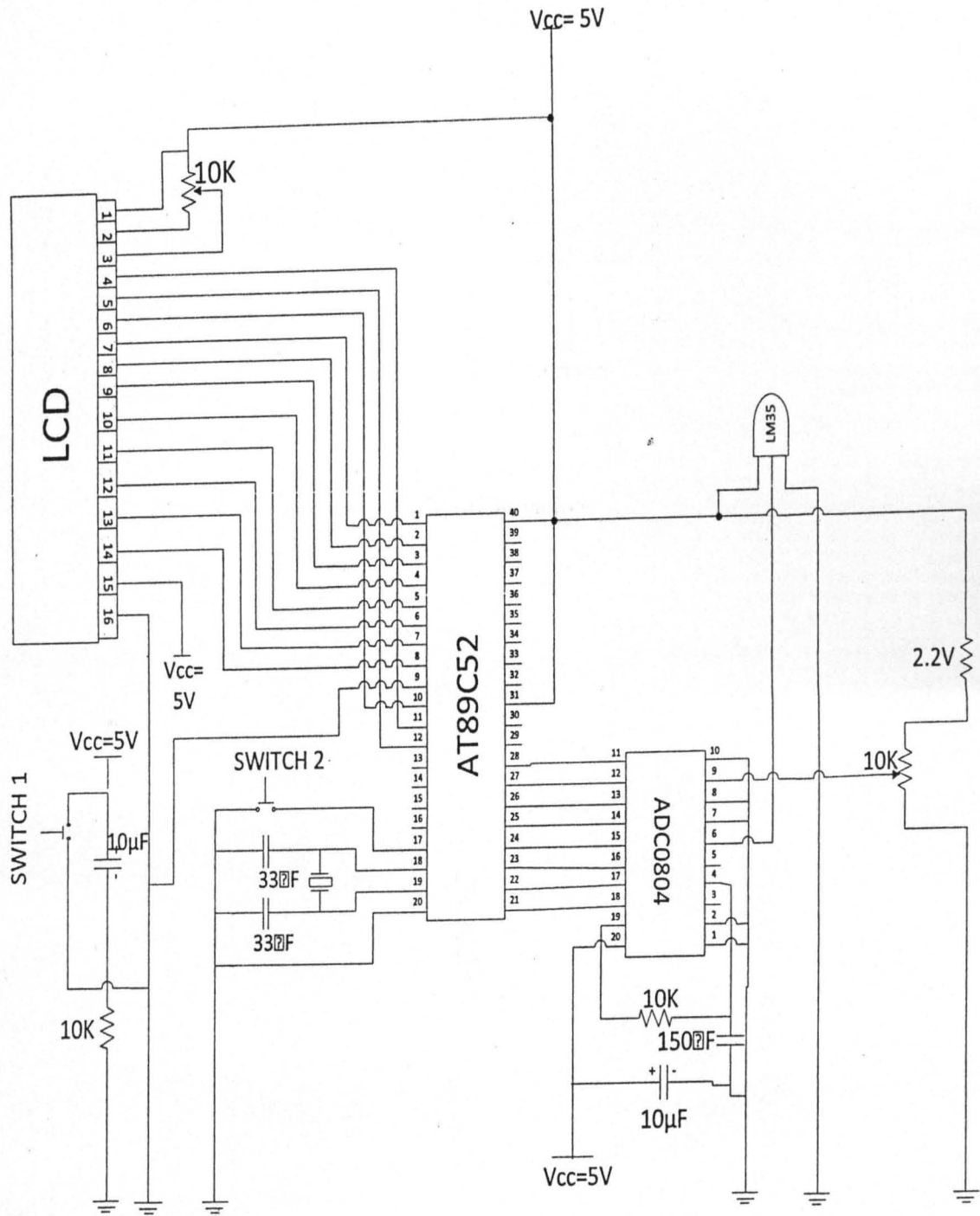

Fig 3.9 Circuit diagram of the project

## **CHAPTER FOUR**

### **4.0 TESTS, RESULT, AND DISCUSSION**

#### **4.1 TESTS**

The test of this project design started with the components test, sensor test then the general circuit test.

##### **4.1.1 COMPONENTS TEST**

All components were tested and confirmed to be good and conformed to the standard specification as describe in the circuit diagram using a multimeter.

##### **4.1.2 SENSOR TEST**

The test of the sensor (LM35) was done using a battery as the power supply. This was done by connecting the positive terminal of the battery to the left pin (voltage in), the negative terminal to the right pin (ground) of the sensor. Then connect the multimeter in DC voltage mode to the right pin (ground) and the middle pin (analog voltage out).

##### **4.1.3 GENERAL CIRCUIT TEST**

After the sensor and all other components were tested, they were connected on a breadboard as connected on the circuit diagram. This is done so as to test the circuit response if it gives the result as expected of the proposed project design. Continuity was tested for each unit

using a multimeter, taking into consideration polarity of each component. Bridging of these components was also tested so as not to cause damage to the components and interruption of the circuit from given the expected result when powered. After all tests have been completed, the circuit was transferred to a vero board for permanent soldering still maintaining the unit arrangement as in the breadboard.

## 4.2 TOOLS USED

- **MULTIMETER:** This is the most fundamental part of electronics is being able to see what amount of voltage, current, or resistance are in a specific component. This is always the first step to do before making use of any of the components in the construction of any project.
- **BREADBOARD:** This also known as proto board and it is use to make a preliminary version of this project for test purposes. It consists of tiny holes which has been filled with conductor and are interconnected in a specific pattern.
- **VERO BOARD:** This was used to permanently construct the project for application purpose. It consists of parallel strips of copper track on one side. The tracks are 0.1" (2.54mm) apart and holes at every 0.1" (2.54mm)
- **SOLDERING IRON:** A 40W 240V soldering iron with lead was used to permanently solder the different components to the vero board.
- **SUCTION TUBE:** Use to clean up excess or wrong placed lead from the board surface in order to avoid short circuits and get a neat soldering.

### 4.3 PHOTOGRAPHIC PLATES OF THE CONSTRUCTED WORK

The photograph in plate 4.1 shows the constructed body temperature monitoring device in its casing.

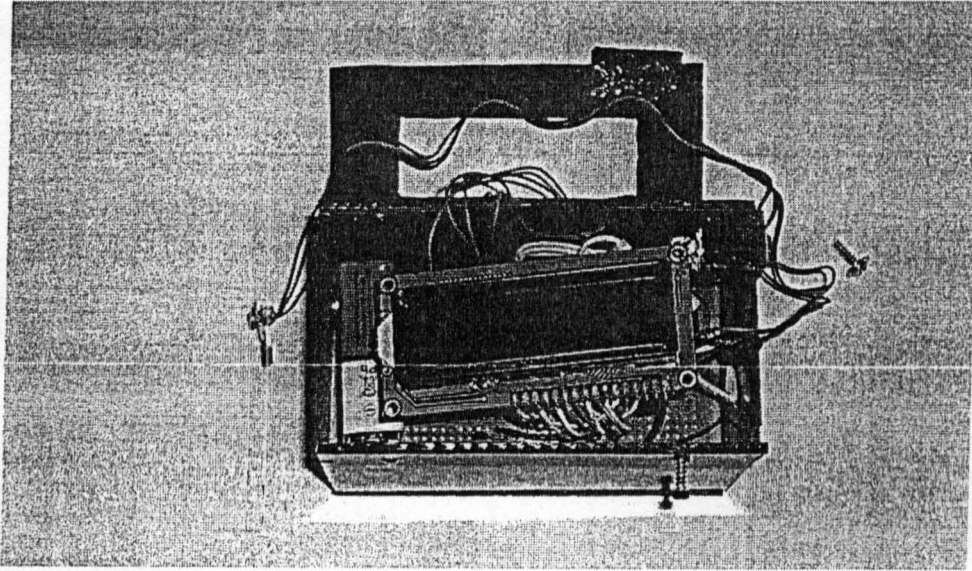

Plate 4.1: The body temperature monitoring device in its casing.

#### 4.4 RESULTS AND DISCUSSION

The response of the temperature sensor was first tested with the aid of a soldering iron and was found to be good and agree with the standard as expected. Table 4.1 shows a relationship between the voltage output of the sensor and the temperature reading on the LCD.

Table 4.1 showing voltage- temperature relationship of the sensor

S/N	Vout of temperature of sensor(mV)	LCD reading( $^{\circ}$ C)
1	25	25
2	30	30
3	35	35
4	37	37
5	38	38
6	40	40
7	45	45

The results obtained conform to the standard conversion of the temperature sensor (LM35) as stated in the datasheet.



## CHAPTER FIVE

### 5.0 CONCLUSION AND RECOMMENDATION

#### 5.1 CONCLUSION

The objectives of this project to measure body temperature, monitor body temperature, determine body temperature variation with time, and to determine body temperature at a specific time of interest had been successfully achieved. With this achieved, individual and care givers are saved from the stress they repeatedly consume when manually reading body temperature as required by other conventional devices.

#### 5.2 PROBLEMS ENCOUNTERED

The following problems were encountered during the course of designing and constructing the project

- i. Configuring the ADC0804 to be able to work with the AT89C52 microcontroller
- ii. Writing the subroutine to display the temperature reading on the LCD
- iii. Troubleshooting of the circuit for short circuitry

#### 5.3 RECOMMENDATION

I recommend that this project be improved in the area of durability and continuity in power supply, and also in the area of using a bluetooth or wireless connection between the temperature sensor and conversion unit



## REFERENCES

- [1] <http://www.temperature.com>  
[\medicalandclinicaltemperaturemeasurementsandusesoftemperaturesensors.htm](http://www.temperature.com/medicalandclinicaltemperaturemeasurementsandusesoftemperaturesensors.htm)
- [2] <http://www.powells.com/biblio?show=0553587129&page=expert>
- [3] <http://www.annemergmed.com/article/piis0196064404002318/fulltext>
- [4] <http://www.ladaya.net/media/sensor/LM35.pdf>
- [5] "Gabriel Daniel Fahrenheit." Microsoft® Encarta® 2009 [DVD]. Redmond, WA: Microsoft Corporation, 2008.
- [6] Landis, Fred. "Thermometer." Microsoft® Encarta® 2009 [DVD]. Redmond, WA: Microsoft Corporation, 2008.
- [7] F. (Sherwood) Taylor, the origin of thermometer (Annals of science), TBU Publication, Britain, 2003, pp129-157
- [8] <http://www.brannan.co.uk/thermometer/invention.html>
- [9] Vern J. Ostdiek and Donald J. Bord, Inquiry into physics, TKY Ltd, New York city USA, 2<sup>nd</sup> edition 2000, pp198-243
- [10] <http://www.microelectronika.com/Picmicrocontrollerschapter1-introductiontomicrocontrollers.html>
- [11] B.L. Theraja & A.K. Theraja, "Textbook of Electrical Technology", Twenty-Fourth Edition. S. Chand & Company Ltd, Ram Nagar, New Delhi. 2005, pp. 2177

## APENDIX I

These temperature variations and effects are the bases which the threshold set point for the AT89C52 microcontroller was chosen

### When Hot:

37°C – Normal body temperature

38°C – Sweating, feeling very uncomfortable, slightly hungry

39°C – Severe sweating, flushed. Fast heart rate and breathlessness. There may be exhaustion accompanying this. Children and adult with epilepsy may be likely to get convulsion at this temperature.

40°C – Fainting, dehydration, weakness, vomiting, headache and dizziness may occur as well as profuse sweating.

41°C (Medical emergency) – Fainting, vomiting, severe headache, dizziness, confusion, hallucination, delirium and drowsiness can occur. There may also be palpitations and breathlessness.

42°C – Subject may turn pale or remain flushed and red. The may pass out, be in severe delirium, vomiting and convulsion can occur. Also, blood pressure may be high or low and heart rate will be very fast.

43°C – Death occur, or there may be serious brain damage. Cardio-respiratory collapse will occur.

44-45°C or more – Almost certainly death will occur.

**When cold:**

37°C – Normal body temperature

36°C – May drop this low during sleep (May be a normal body temperature).

However, mild to moderate shivering can occur.

35°C – Intense shivering, numbness and grayness of the skin. There is the possibility of heart irritability.

34°C – Severe shivering, loss of movement of fingers. Some behavioural changes may take place.

33°C – Moderate to severe confusion, sleepiness, depressed reflexes, progressive loss of shivering, slow heart beat shallow breathing. Shivering may stop due to the subject's unresponsiveness to certain stimuli.

32°C – (Medical emergency) Hallucination, extreme sleepiness that is progressively becoming comatose. Shivering is absent. Reflex may be absent or very slight.

31°C – Rarely conscious. No or reflexes. Very shallow breathing and slow heart rate. Possibility of serious heart rhythm problems.

28°C – Severe heart rhythm disturbances are likely to occur and breathing may stop at some time.

25-27°C or less – Death usually occurs due to irregular heart beat or respiratory failure.

## APPENDIX II

### $V_{ref}/2$ Relation to $V_{in}$ Range

$V_{ref}/2(v)$	$V_{in}(V)$	Step Size ( mV)
Not connected*	0 to 5	$5/256=19.53$
2.0	0 to 4	$4/255=15.62$
1.5	0 to 3	$3/256=11.71$
1.28	0 to 2.56	$2.56/256=10$
1.0	0 to 2	$2/256=7.81$
0.5	0 to 1	$1/256=3.90$

## APPENDIX III

```
ORG 0000H
CLR A
TEMP_DATA EQU P2
TEMP_CON EQU P3.3
DB0 EQU P1.0
DB1 EQU P1.1
DB2 EQU P1.2
DB3 EQU P1.3
DB4 EQU P1.4
DB5 EQU P1.5
DB6 EQU P1.6
DB7 EQU P1.7
LCD_DATA EQU P1
EN EQU P3.0
RS EQU P3.1
RW EQU P3.2
MOV R0,#00H
MOV R1,#00H
MOV R2,#00H
MOV R3,#00H
BOTTON EQU P3.7
MAIN: MOV TEMP_DATA, #0FFH
      SETB BOTTON
      LCALL HELLO
      CLR TEMP_CON
      JB BOTTON, $
      LCALL GET_TEMP
      LCALL CONV_TEMP
      LCALL LOADING
      ACALL DELAY
      LCALL PLEASE
      ACALL DELAY
      LCALL RESULT

TEST0: CLR A
      MOV A, R3
      CJNE A, #25, TEST1
      LCALL LOW
TEST1: CJNE A, #26, TEST2
      LCALL LOW
TEST2: CJNE A, #27, TEST3
      LCALL LOW
TEST3: CJNE A, #28, TEST4
      LCALL LOW
TEST4: CJNE A, #29, TEST5
      LCALL LOW
TEST5: CJNE A, #30, TEST6
      LCALL LOW
TEST6: CJNE A, #31, TEST7
      LCALL LOW
TEST7: CJNE A, #32, TEST8
      LCALL LOW
TEST8: CJNE A, #33, TEST9
      LCALL LOW
TEST9: CJNE A, #34, TEST10
      LCALL LOW
TEST10: CJNE A, #35, TEST11
      LCALL NORMAL
TEST11: CJNE A, #36, TEST12
      LCALL NORMAL
TEST12: CJNE A, #37, TEST13
      LCALL NORMAL
TEST13: CJNE A, #38, TEST14
      LCALL NORMAL
```

```

TEST14: CJNE A, #39, TEST15
        LCALL NORMAL
TEST15: CJNE A, #40, TEST16
        LCALL HIGH
TEST16: CJNE A, #41, TEST17
        LCALL HIGH
TEST17: CJNE A, #42, TEST18
        LCALL HIGH
TEST18: CJNE A, #43, TEST19
        LCALL HIGH
TEST19: CJNE A, #44, TEST20
        LCALL HIGH
TEST20: CJNE A, #45, STAY
        LCALL HIGH
STAY:   JB BOTTON, $
        AJMP MAIN
DELAY:  PUSH 00H
        PUSH 01H
        PUSH 02H
        MOV 00H, #12
TOPE:   MOV 01H, #195
HERE:   MOV 02H, #254
        DJNZ 02H, $
        DJNZ 01H, HERE
        DJNZ 00H, TOPE
        POP 02H
        POP 01H
        POP 00H
        RET

```

```

WAIT_LCD: CLR EN
          CLR RS
          SETB RW
          MOV LCD_DATA, #0FFH
          SETB EN
          MOV A, LCD_DATA
          JB ACC.7, WAIT_LCD
          CLR EN
          CLR RW
          RET

```

```

INIT_LCD: CLR RS
          MOV LCD_DATA, #38H
          SETB EN
          CLR EN
          LCALL WAIT_LCD
          CLR RS
          MOV LCD_DATA, #0EH
          SETB EN
          CLR EN
          LCALL WAIT_LCD
          CLR RS
          MOV LCD_DATA, #06H
          SETB EN
          CLR EN
          LCALL WAIT_LCD
          RET

```

```

CLR_LCD: CLR RS
          MOV LCD_DATA, #01H
          NIT_LCD
          LCALL CLR_LCD
          MOV A, #'I'
          LCALL WRITE_TEXT
          MOV A, #'N'
          LCALL WRITE_TEXT
          MOV A, #'T'
          LCALL WRITE_TEXT
          MOV A, #'T'

```

```

LCALL WRITE_TEXT
MOV A,#'I'
LCALL WRITE_TEXT
MOV A,#'A'
LCALL WRITE_TEXT
MOV A,#'L'
LCALL WRITE_TEXT
MOV A,#'T'
LCALL WRITE_TEXT
MOV A,#'Z'
LCALL WRITE_TEXT
MOV A,#'I'
LCALL WRITE_TEXT
MOV A,#'N'
LCALL WRITE_TEXT
MOV A,#'G'
LCALL WRITE_TEXT
MOV A,#'.'
LCALL WRITE_TEXT
MOV A,#'.'
LCALL WRITE_TEXT
RET
GET_TEMP:CLR TEMP_CON
          MOV R3 , #00H
          CLR A
          NOP
          MOV A , TEMP_DATA
          MOV R3 , TEMP_DATA
          NOP
          RET
CONV_TEMP:
          MOV B , #00H
          MOV B , #100
          DIV AB
          MOV R0, A
          CLR A
          MOV A, B
          MOV B , #00

          CLR A
          ACALL ORGANIZ
          CLR A
          MOV A, 20H
          MOV R2, A
          RET
ORGANIZ:
ONE:CJNE A, #00H, TWO
      MOV 2H, #00H
      RET
TWO:CJNE A, #01H, THREE
      MOV H, #01H
      RET
THREE:CJNE A, #02H, FOUR
      MOV 20H, #02H
      RET
FOUR:CJNE A, #03H, FIVE
      MOV 2H, #03H
      RET
FIVE: CJNE A, #04H, SIX
      MOV 20H, #04H
      RET
SIX:   CJNE A, #05H, SEVEN
      MOV 2H, #05H
      RET
SEVEN: CJNE A, #06H, EIGHT
      MOV 20H, #06H

```



```

      RET
EIGHT: CJNE A, #07H, NINE
        MOV H, #07H
        RET
NINE:   CJNE A, #08H, TEN
        MOV 2H, #08H
        RET
TEN:    CJNE A, #09H, ELEVEN
        MOV 20H, #09H
        RET

ELEVEN:RET
LOADING: LCALL CLR_LCD
        MOV A, #'L'
        ACALL WRITE_TEXT
        MOV A, #'O'
        ACALL WRITE_TEXT
        MOV A, #'A'
        ACALL WRITE_TEXT
        MOV A, #'D'
        ACALL WRITE_TEXT
        MOV A, #'I'
        ACALL WRITE_TEXT
        MOV A, #'N'
        ACALL WRITE_TEXT
        MOV A, #'G'
        ACALL WRITE_TEXT
        MOV A, #'.'
        ACALL WRITE_TEXT
        MOV A, #'.'
        ACALL WRITE_TEXT
        MOV A, #'.'
        ACALL WRITE_TEXT
        MOV A, #'.'
        ACALL WRITE_TEXT
        RET
PLEASE: LCALL CLR_LCD
        MOV A, #'P'
        ACALL WRITE_TEXT
        MOV A, #'L'
        ACALL WRITE_TEXT
        MOV A, #'E'
        ACALL WRITE_TEXT
        MOV A, #'A'
        ACALL WRITE_TEXT
        MOV A, #'S'
        ACALL WRITE_TEXT
        MOV A, #'E'
        ACALL WRITE_TEXT
        MOV A, #'.'
        ACALL WRITE_TEXT
        MOV A, #'W'
        ACALL WRITE_TEXT
        MOV A, #'A'
        ACALL WRITE_TEXT
        MOV A, #'I'
        ACALL WRITE_TEXT
        MOV A, #'T'
        ACALL WRITE_TEXT
        RET
RESULT: LCALL CLR_LCD
        MOV A, #'T'
        ACALL WRITE_TEXT
        MOV A, #'E'
        ACALL WRITE_TEXT
        MOV A, #'M'
        ACALL WRITE_TEXT
        MOV A, #'P'
        ACALL WRITE_TEXT

```

```

MOV A,#'
ACALL WRITE_TEXT
MOV A,#='
ACALL WRITE_TEXT
MOV A,#'
ACALL WRITE_TEXT
LCALL ORG_1
ACALL WRITE_TEXT
LCALL ORG_2
ACALL WRITE_TEXT
LCALL ORG_3
ACALL WRITE_TEXT
MOV A,#0DFH
ACALL WRITE_TEXT
MOV A,#'C'
ACALL WRITE_TEXT
RET

```

```

LOW: CLR RS
MOV LCD_DATA,#0C0H
SETB EN
CLR EN
LCALL WAIT_LCD

```

```

MOV A,#'L'
ACALL WRITE_TEXT
MOV A,#'O'
ACALL WRITE_TEXT
MOV A,#'W'
ACALL WRITE_TEXT
MOV A,#'
ACALL WRITE_TEXT
MOV A,#'B'
ACALL WRITE_TEXT
MOV A,#'O'
ACALL WRITE_TEXT
MOV A,#'D'
ACALL WRITE_TEXT
MOV A,#'Y'
ACALL WRITE_TEXT
MOV A,#'
ACALL WRITE_TEXT
MOV A,#'T'
ACALL WRITE_TEXT
MOV A,#'E'
ACALL WRITE_TEXT
MOV A,#'M'
ACALL WRITE_TEXT
MOV A,#'P'
ACALL WRITE_TEXT
RET

```

```

RMAL: CLR RS
MOV LCD_DATA,#0C0H
SETB EN
CLR EN
LCALL WAIT_LCD

```

```

MOV A,#'N'
ACALL WRITE_TEXT
MOV A,#'O'
ACALL WRITE_TEXT
MOV A,#'R'
ACALL WRITE_TEXT
MOV A,#'M'
ACALL WRITE_TEXT
MOV A,#'A'
ACALL WRITE_TEXT
MOV A,#'L'
ACALL WRITE_TEXT

```

```
MOV A, #'  
ACALL WRITE_TEXT  
MOV A, #'B'  
ACALL WRITE_TEXT  
MOV A, #'O'  
ACALL WRITE_TEXT  
MOV A, #'D'  
ACALL WRITE_TEXT  
MOV A, #'Y'  
ACALL WRITE_TEXT  
MOV A, #' '  
ACALL WRITE_TEXT  
MOV A, #'T'  
ACALL WRITE_TEXT  
MOV A, #'E'  
ACALL WRITE_TEXT  
MOV A, #'M'  
ACALL WRITE_TEXT  
MOV A, #'P'  
ACALL WRITE_TEXT  
RET
```

```
HIGH:CLR RS  
MOV LCD_DATA,#0C0H  
SETB EN  
CLR EN  
LCALL WAIT_LCD
```

```
MOV A, #'H'  
ACALL WRITE_TEXT  
MOV A, #'T'  
ACALL WRITE_TEXT  
MOV A, #'G'  
ACALL WRITE_TEXT  
MOV A, #'H'  
ACALL WRITE_TEXT  
MOV A, #' '  
ACALL WRITE_TEXT  
MOV A, #'B'  
ACALL WRITE_TEXT  
MOV A, #'O'  
ACALL WRITE_TEXT  
MOV A, #'D'  
ACALL WRITE_TEXT  
MOV A, #'Y'  
ACALL WRITE_TEXT  
MOV A, #' '  
ACALL WRITE_TEXT  
MOV A, #'T'  
ACALL WRITE_TEXT  
MOV A, #'E'  
ACALL WRITE_TEXT  
MOV A, #'M'  
ACALL WRITE_TEXT  
MOV A, #'P'  
ACALL WRITE_TEXT  
RET
```

```
END
```