

**DESIGN AND CONSTRUCTION OF AN
AUTOMATIC TEMPERATURE CONTROLLED
FAN REGULATOR**

(WITH TEMPERATURE DISPLAY)

BY

AMANA MATTHEW

2003/15323EE

**A THESIS SUBMITTED TO THE DEPARTMENT OF
ELECTRICAL AND COMPUTER ENGINEERING,
FEDERAL UNIVERSITY OF TECHNOLOGY,
MINNA**

NOVEMBER, 2008

DEDICATION

I dedicate this project to God who gave me knowledge, understanding, protection and divine direction throughout my years of studies in the university. I also dedicate this project to the blessed memory of my late mother, Mrs. Mary Joseph Amana a mother with a difference.

DECLARATION

I Amana Matthew declare that this project work was done by me and has never been presented anywhere for the award of a degree. I also hereby relinquish the copyright to Federal university of technology minna .

Amana Matthew

.....
(Name of student)

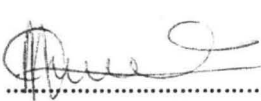
 6/11/2008

.....
(signature and date)

Engr A. G. Raji

.....
(Name of Supervisor)

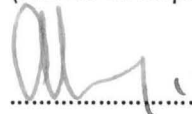
 (Nov. 13, 2008)

.....
(Signature and date)

Engr. Dr Y. A. Adediran

.....
(Name of H.O.D)

.....
(Signature and date)

.....
(Name of external examine)

.....
(signature and date)

ACKNOWLEDGEMENT

My special thanks and appreciation goes to Almighty God for His divine provision and protection over the years I stayed in school. My appreciation also goes to my parents Mr & Mrs Joseph Amana who have been of great help to me in my up bring.

My profound gratitude goes to my head of department Engr. Dr. Adediran, my project supervisor Engr. A. G. Raji and the entire members of the staff. Also my gratitude goes to the entire members of my family, especially Mr Sunday Amana; Steven Amana, James Amana & Mrs Salome Onu. My friends, Matthew S. Egene, Matthew Chukwu, Samon Ogachekwo . Idoko Attahs, Charles Umoru & Emeka Okechukwu who were around me all the time. Finally, my appreciation to all well wishers whose collaborative efforts and assistance make this project a success.

ABSTRACT

An automatic temperature based fan speed regulation and digital temperature display is aimed to show the relationship of a physical quantity (temperature in control and feedback technique) by incorporating an accurate and acceptable error free electronic temperature sensor. The device is merely designed around an input temperature sensor (LM35). It is an integrated circuit with normal transistor-like package that precisely produces an output voltage of 10mV for every 1°C temperature increment, and directly proportional relationship. An ADC0804, Analogue to Digital Converter integrated circuit, is needed to convert the analogue, voltage, from the LM35 temperature sensor into 8-bit code that is fed into a calibrating logic. The fan regulation is achieved through the inductive reactance effect of an inductor in an AC power line.

TABLE OF CONTENT

Title page.....	i
Dedication.....	ii
Declaration.....	iii
Acknowledgement.....	iv
Abstract.....	v
Table of contents.....	vi
List of figures.....	ix
Chapter One: Introduction.....	1
1.1 Scope of the project.....	1
1.3 Aims and objectives.....	1
1.4 Methodology.....	2
1.5 Limitations.....	3
Chapter Two: Literature Review.....	4
2.1 Theoretical background.....	4
2.1.2 Thermometer.....	4
2.1.3 Brief history of thermometer.....	5
2.1.4 Silicon temperature sensor.....	6
2.2 Fan.....	7
2.2.1 Brief history of fan.....	7
2.2.2 Ceiling Fan.....	7
2.2.3 Uses of ceiling fan.....	8

2.2.4	Methods of regulating the speed of a ceiling fan.....	9
2.2.4.1	Pull chain / pull Cord Control.....	9
2.2.4.2	Variable speed control.....	9
2.2.4.3	Digital control.....	9
2.2.4.4	Wireless remote control.....	10
2.3	Theoretical background.....	10
2.3.1	Temperature sensor.....	11
2.3.2	Analogue to digital converter.....	11
2.3.3	Output calibrating unit.....	11
2.3.4	Speed regulation switching unit.....	11
2.3.5	Display unit.....	12
2.4	Main Components Description	12
2.4.1	LM35.....	12
2.4.2	ADCO804.....	13
2.4.2.1	Pin Number Description.....	15
2.4.2.2	40103B.....	15
2.4.2.3	4081B.....	17
2.4.2.4	4069B.....	17
2.4.2.5	4518B.....	18
2.4.2.6	4511B.....	18
2.4.2.7	4017B.....	19
2.4.2.8	4060B.....	20
2.4.2.9	40174B.....	21
2.4.2.10	2SC945 Transistor.....	22

Chapter Three: Design and Construction	23
3.0 Circuit design analysis.....	23
3.1 Power unit.....	23
3.2 Temperature sensing unit.....	24
3.3 Analogue to digital converter (ADC).....	24
3.4 Output Calibration.....	25
3.4.1 Control Oscillator.....	28
3.5 Display Unit.....	30
3.6 Fan Speed Regulating/Switching Unit.....	31
3.6.1 Stepper A /latch circuit.....	32
3.6.2 Switching transistor relay circuit.....	32
3.6.3 Speed indicator.....	34
3.6.4 Stepper B manual control	35
3.6.5 Speed Regulation Transformer.....	36
Chapter Four: Construction, testing and discussion of result	39
4.1 Circuit Construction.....	39
4.1.1 Casing Construction	40
4.2 Testing.....	40
4.3 Result Discussion.....	42
Chapter Five: Conclusion and recommendation	43
5.1 Conclusion	43
5.2 Recommendation.....	43
References	44

LIST OF FIGURE

Fig. 2.1	The block diagram.....	10
Fig. 2.2	Pin configuration of the LM35.....	13
Fig. 2.3	Pin layout of the ADC0804.....	14
Fig. 2.4	Pin configuration of the 40103B.....	16
Fig. 2.5	Pin configuration of the 4081B.....	17
Fig. 2.6	Pin configuration of the 4069B.....	17
Fig. 2.7	Pin configuration of the 4518B.....	18
Fig. 2.8	Pin configuration of the 4511B.....	19
Fig. 2.9	Pin configuration of the 4060B.....	20
Fig. 2.10	Pin assignment of the 40174B.....	21
Fig. 2.11	Pin configuration of the 2SC945.....	22
Fig. 3.1	The Power Unit	24
Fig. 3.2	Temperature Sensor Circuit.....	24
Fig. 3.3	The analogue to Digital converter circuit.....	25
Fig. 3.4	The output calibrating unit.....	27
Fig. 3.5	Display unit.....	30
Fig. 3.6	The Speed regulating unit.....	32
Fig. 3.7	A single switching transistor/relay circuit.....	33
Fig. 3.8	Speed Display.....	33
Fig. 3.9	A single speed indicator circuit.....	34
Fig. 3.10	The stepper B manual control circuit.....	35
Fig. 3.11	An inductive AC circuit.....	36
Fig. 3.12	Simplified speed regulation circuit.....	37
Fig. 3.13	The casing.....	40

CHAPTER ONE

1.0 INTRODUCTION

1.1 HISTORICAL BACKGROUND

The project involves the design and construction of an automatic temperature-controlled fan regulator. The device is designed to automatically regulate the speed of a fan in order to moderate room temperature within an acceptable and convenient range. The fan is automatically switched to blow faster in response to relatively high room temperatures; with respect to certain preset values. The opposite is the case when the temperature is quite low. It even goes completely off when the temperature is too low for the room.

Moreover, the control technique merely allows a convenient temperature to be attained in the room through speed regulation of the fan. The fan can also be controlled manually, if necessary.

This technology, the device, can be used in a hotel, church, hall, classroom and even, mere room in keeping the temperature within a convenient range. In fact, it reduces the stress of manually trying to get the task done.

1.2 SCOPE OF WORK

The main scope of this project is to design a temperature monitoring circuit with digital display, using a single integrated circuit temperature sensor, which regulates the speed of a fan based on preset temperature ranges.

1.3 AIMS AND OBJECTIVES

The main purpose of the project is to demonstrate the application of electronics in temperature regulation or control. Also, it is aimed to show the relationship between a physical quantity (temperature) in electronic control and feed-back techniques.

OBJECTIVES

- To make the circuit highly digital
- The use of readily available electronic components and materials
- The use of minimum parts for economic.
- To incorporate an accurate and acceptable error- free electronic temperature sensor.
- To display temperature digitally.
- Also, the fan's speed is displayed on a LED panel.
- To incorporates error reduction logics in order the device's operation aspectable.

1.4 METHODOLOGY

The device is merely designed around a input temperature sensor (LM35).It is an integrated circuit with normal transistor-like package that precisely produces an output voltage of 10mV for every 1°C temperature increment, an directly proportional relationship. That is, a temperature of 34°C is detected as $34 \times 10\text{mV} = 340\text{mV}$ or 0.34V at the output of the temperature sensor. Therefore, the physical quantity, temperature, is electrically recognized through the sensor.

An ADC0804, Analogue to Digital Converter integrated circuit, is needed to convert the analogue, voltage, from the LM35 temperature sensor into 8-bit code that is fed into a calibrating logic. The corresponding result from the latter unit is fed into temperature display panel and a switching relay circuit which accordingly alter the speed of the fan. The fan regulation is achieved through the inductive reactance effect of an inductor in an AC power line. The inductor or transformer is connected in series to the fan and the more the inductance in the connection the lower the speed of the fan, due to voltage drop across it .At the highest speed the inductance is zero, and that is, the fan is directly connected to the AC mains.

The speed regulating/switching unit is designed to respond to 27 and lower, 28-31, 32-35, and above 36°C temperature ranges for OFF, LOW, MEDIUM and HIGH speed control respectively of the fan. These ranges can be easily altered for different environments. A 3-LED display panel indicates the speed of the fan.

1.5 LIMITATIONS

- The project is based on 4-speed control technique in which greater one could have provide better temperature regulation.
- The use of a single temperature sensor could result to error because the temperature around points in the room might vary.
- There is no remote controlled unit.
- The design is not meant for multiple fan control.

CHAPTER TWO

2.0 LITERATURE REVIEW

As early stated in chapter 1, the project involves a temperature measuring circuit that controls a fan regulating unit. Therefore, this chapter would embody both temperature and fan related topics.

2.1 THEORETICAL BACKGROUND

Temperature can be simply defined as the degree of hotness or coldness of a body or environment (corresponding to its molecular activity) [1]. Temperature is the most often-measured environmental quantity. This might be expected since most physical, electronic, chemical, mechanical and biological systems are affected by temperature. Atmospheric temperature is quite important to human body. Temperature plays an important role in determining the rate and extent to which chemical reactions occur. This is one reason why the human body has several elaborate mechanisms for maintaining the temperature at 37 °C, since temperatures only a few degrees higher can result in harmful reactions with serious consequences. [2] Temperature can be measured in several ways that centered on one and the same concept; that temperature causes clear changes on matter.

2.1.2 Thermometer

A thermometer is a device designed for temperature or temperature gradient measurement, using numerous techniques. The word “thermometer” is derived from two smaller word fragments: “thermo” from the Greek for heat and “meter” also from Greek, meaning “to measure”. [3] A thermometer has two important elements, the temperature sensor or a temperature sensitive element (e.g. the bulb on a mercury thermometer) in which some physical change occurs with temperature, plus some means of converting this physical change into a value (e.g. the scale on a mercury thermometer). Modern thermometers commonly use electronic means to provide temperature information in form of display. In the case of this

project, the LM35 integrated circuit and 7-segment display as its temperature sensor and reading scale respectively. This technique is attributed to a high level of accuracy.

2.1.3 Brief History of Thermometer

Thermometer is a longstanding invention. Galileo passed for the invention of the first thermometer in the late 1600s. The exact year is not known, but historians estimate that it was somewhere in 1593. The leading device was a crude temperature-measuring instrument without no scale and therefore no numerical readings.

In 1665, Christiana Huygens added a scale extending from the freezing point to the boiling point of water, the original centigrade system. Gabriel Daniel Fahrenheit contributed to the development of thermometer through a new scale on a mixture of ice and ammonium chloride as the lower point. He found a new sensing material, mercury, more useful than often used water, as it expanded and contracted more rapidly. Gabriel Fahrenheit invented the first reliable mercury thermometer in 1714. The Fahrenheit Temperature Scale is attributed to him.

Moreover, Anders Celsius had a major role in developing another popular scale for thermometers. In 1742, the Swedish astronomer, reintroduced the centigrade scale into practice, but despite improvements in design of the thermometer, its use remained largely neglected until the late 19th century.

Today's thermometers are made in different ways. The most common is the alcohol or mercury thermometer. Expansion Thermometers are other kinds of thermometers, they are usually made of two different metals that expand and contract at different rates when the air temperature changes. The metals are fused together and wound like a spring. When the temperature changes, the spring either unwinds or winds up. A needle is connected to the spring and points to the indicated air temperature. [4]

Recent advances in thermometer design include digital, electronic direct and predictive, infra-red ear thermometers, and dot-matrix or phase-change thermometers. These devices are advanced and built around semiconductor technology.

2.1.4 Silicon Temperature Sensors

Integrated circuit temperature sensors differ significantly from the other types in a couple of important ways. The first is operating temperature range. A temperature sensor IC can operate over the nominal IC temperature range of -55°C to $+150^{\circ}\text{C}$. Some devices go beyond this range, while others, because of package or cost constraints, operate over a narrower range. The second major difference is functionality. A silicon temperature sensor is an integrated circuit, and can therefore include extensive signal processing circuitry within the same package as the sensor. You don't need to design cold-junction compensation or linearization circuits for temperature sensor ICs, and unless you have extremely specialized system requirements, there is no need to design comparator or ADC circuits to convert their analog outputs to logic levels or digital codes. Those functions are already built into several commercial ICs. [5]

2.2 FAN

A fan is a device used to induce airflow for the purpose of cooling or refreshing an enclosure or room through the rotation of its blades. Any broad, flat surface waved back-and-forth will create a small airflow and therefore can be considered a rudimentary fan. A common form of fan is the ceiling type. It is a device suspended from the ceiling of a room, which employs hub-mounted rotating paddles to circulate air in order to produce a cooling or desertification effect. [6]

2.2.1 Brief History of fan

The first recorded fan was mechanical based. It was the punkah fan used in the Middle East in the 1500s. It had a canvas covered frame that was suspended from the ceiling. Servants, known as punkah wallahs, pulled a rope connected to the frame to move the fan back and forth.

The Industrial Revolution in the late 1800s introduced belt-driven fans powered by factory waterwheels. Attaching wooden or metal blades to shafts overhead that were used to drive the machinery, the first industrial fans were developed. One of the first workable mechanical fans was built by A.A. Sablukov in 1832. He called his invention, a kind of a centrifugal fan, an Air Pump. Centrifugal fans were successfully tested inside coal mines and factories in 1832-1834. When Thomas Edison and Nicola Tesla introduced electrical power in the late 1800s and early 1900s for the public, the personal electrical fan was introduced. Between 1882 and 1886, Dr. Schuyler Skaats Wheeler developed the two-bladed desk fan, a type of personal electric fan. It was commercially marketed by the American firm Crocker & Curtis Electric Motor Company. In 1882, Philip H. Diehl introduced the electric ceiling fan. Diehl is considered the father of the modern electric fan. In the late 1800s, electric fans were used only in commercial establishments or in well-to-do households. Heat-convection fans fueled by alcohol, oil, or kerosene were common around the turn of the 20th century.

In the 1920s, industrial advances allowed steel to be mass-produced in different shapes, bringing fan prices down and allowing more homeowners to afford them. [6]

Today, electric fans have been largely replaced by air conditioners in most households and offices, even though electric fans consume much less energy than air conditioners.

2.2.2 Ceiling Fan

The project is designed for one ceiling fan. Although a table fan is intended for test at the project defense. Based on records, the first ceiling fans appeared in the 1860s and 1870s, in

the United States. At that time, they were not powered by any form of electric motor. Instead, a stream of running water was used, in conjunction with a turbine, to drive a system of belts which would turn the blades of two-blade fan units. These systems could accommodate several fan units, and so became popular in stores, restaurants, and offices.

The electrically-powered ceiling fan was invented in 1882 by Philip Diehl. Diehl had engineered the electric motor used in the first Singer sewing machines, and in 1882 adapted that motor for use in a ceiling-mounted fan. "The Diehl Electric Fan", as it was known, operated like a common modern-day ceiling fan; each fan had its own self-contained motor unit, eliminating the need for costly and bulky belt systems. [5]

However, today, the ceiling fan is a house-hold device in many countries, like Nigeria, notably those with warm climates which could not afford high-energy-consuming devices, like air conditioner.

2.2.3 Uses of Ceiling fan

Standard ceiling fans can be used in two different ways; that is, most fans have a mechanism, commonly an electrical switch, for reversing the direction in which the blades rotate. In Nigeria, such types are rare; most ceiling fans operate in a one direction.

In hot weather, when the fan's direction of rotation is set so that air is blown downward (typically counter-clockwise, when standing under the fan and looking upwards), the breeze created by a ceiling fan speeds the evaporation of sweat on human skin, which is experienced as a cooling effect. This usage of ceiling fan is known in Nigeria. This project enhances the leading usage of ceiling fan by automatically regulating the speed of a fan with temperature variation in keeping a room convenient.

In cold weather of a country like United States of America, buildings are usually heated. In this process, warmer air rises to the ceiling while cooler air sinks to the floor. A ceiling fan, with its direction of rotation set so that air is drawn upward (typically clockwise), takes cool air from lower levels in the room and pushes it upward towards the ceiling. The warm air, which had naturally risen to the ceiling, is forced out of the way of the incoming cool air; it travels along the ceiling and down the walls, to lower levels where people in the room can feel it for convenience.

2.2.4 Methods of Regulating the Speed of a Ceiling Fan

The method or Technology in which a fan is operated depends on its manufacturer, style, era, and purpose in which it was designed. The method used in the project is not common and quite a development in speed regulation of fan. Some operating methods are as follow. [6]

2.2.4.1 Pull-chain/pull-cord control

This is the most widely common manual method of operation for household fans. But, it is quite rare in Nigeria. This style of fan is equipped with a metal-bead chain or cloth cord which, when pulled, cycles the fan through the operational speed(s) and then back to off. These fans usually possess three speeds (high, medium, and low. [6]

2.2.4.2 Variable-speed control

This style of control is very common in Nigeria.. It involves a wall-mounted rotary click-type switch for the infinite-speed dial, providing a set number of speeds (usually five). [6]

2.2.4.3 Digital control

With this style of control, all of the fan's functions--on/off status, speed, direction of rotation, and any attached light fixtures--are controlled by a computerized wall control, which typically

does not require any special wiring. Instead, it uses the normal house wiring to send coded electrical pulses to the fan, which decodes and acts on them using a built-in set of electronics. This style of control typically has anywhere from three to six speeds. It is really expensive and not common. [6]

2.2.4.4 Wireless remote control

The vast development of Electronics allows remote controls to become an affordable alternative for controlling ceiling fans. The modern hand-held remote transmits infrared signals to a receiver unit installed in the fan, which interprets and acts on the signals. The users of this technology enjoy ease in operating their air blowers. [6]

THEORETICAL BACKGROUND

This project is designed around the following block diagram.

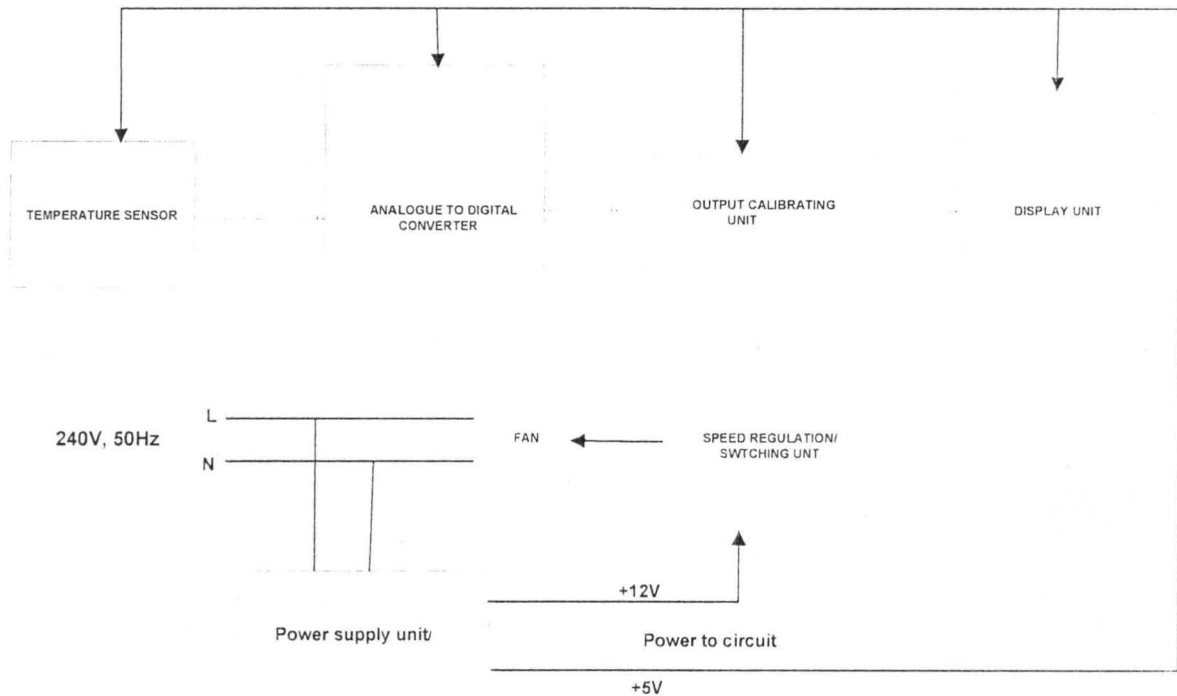

Fig 2.1 The Block Diagram

2.3.1 Temperature Sensor

Temperature sensor such as the LM35 is an integrated circuit with normal transistor-like package that precisely produces an output voltage of 10mV for every 1°C temperature increment; a directly proportional relationship. That is, a temperature of 25°C is detected as $25 \times 10\text{mV} = 250\text{mV}$ or 0.25V at the output of the temperature sensor. Therefore, the physical quantity, temperature, is electrically recognized through the sensor in a linear scale.

2.3.2 Analogue to Digital Converter

Analogue to Digital Converter (ADC) integrated circuits are designed to convert an analogue signal, voltage, to corresponding calibrated code or digital signal. These components can necessitate the possibility of displaying the temperature at the temperature sensor on a LED panel. This is achieved through careful calibration of the Analogue to Digital Converter circuit in-line with the input temperature sensor.

2.3.3 Output calibrating Unit

This is a circuit that contains logical integrated circuits and designed to correctly display the temperature at the temperature sensor on a display. It also provides temperature limits or marks, for instance the temperatures at which the speed of the fan is altered, for the output to respond to.

2.3.4 Speed Regulation/ Switching Unit

This unit consists of relay circuits that receive control signal from the output of the decoder in switching a particular speed for the fan. The fan regulation is achieved through the inductive reactance effect of an inductor in an AC power line.

This can be expressed mathematically from universal equation of Electric motor and transformers:

$E = 4.44k\phi f$; where E = potential difference in an electric motor

ϕ = magnetic flux density

f = frequency

k = Number of winding

$\phi = I L$; where L = inductance of the inductor

I = current

Also $f = Np$; where N = angular speed in revolution per second

$$\Rightarrow E = 4.44KLINp$$

$$N = \frac{E}{4.44KLINp}$$

From the expression,

$$N \propto 1/L$$

From the relationship between N and L, it implies angular speed [N] is inversely proportional to the inductance of an inductor [10].

2.3.5 Display Unit

The display unit is incorporated into the design to make visible any out going digital information. This unit involves digit counters, decoders, and 7-segment display panel.

2.4 MAIN COMPONENTS DESCRIPTION

The circuit design involves limited number of components. They are also cheap and readily available. The involved integrated circuits are CMOS type which makes the circuit low power consumption and high flexibility. [7]

2.4.1 LM35

The LM35 series are common precision integrated-circuit temperature sensors, whose output voltage is linearly proportional to the Celsius (Centigrade) temperature. The LM35 thus

has an advantage over linear temperature sensors calibrated in ° Kelvin, as the user is not required to subtract a large constant voltage from its output to obtain convenient Centigrade scaling. The LM35's low output impedance, linear output, and precise inherent calibration make interfacing to readout or control circuitry especially easy. It can be used with single power supplies, or with plus and minus supplies. As it draws only 60mA from its supply, it has very low self-heating, less than 0.1 °C in still air. The LM35 is rated to operate over a 55° to a 150°C temperature range.

The temperature sensor produces an output of 10m°V for every 1C temperature detected. It possesses a Linear a 10.0 mV/ °C scale factor.

The LM35 series is available packaged in hermetic TO-46 transistor packages, while the LM35C, LM35CA, and LM35D are also available in the plastic TO-92 transistor package. The LM35D is also available in an 8-lead surface mount small outline package and a plastic TO-202 package. The TO-92 transistor casing package is commonly available.



Fig. 2.2 Pin configuration of the LM35 [8]

2.4.2 ADC0804

The ADC0804 is a CMOS 8-bit successive approximation A/D converter which uses a differential potentiometric ladder- similar to the 256R products. This converter is designed to allow operation with the NSC800 and INS8080A derivative control bus with TRI-STATEÉ

output latches directly driving the data bus. This A/D appears like memory locations or I/O ports to the microprocessor and no interfacing logic is needed. Differential analog voltage inputs allow increasing the common-mode rejection and offsetting the analog zero input voltage value. In addition, the voltage reference input can be adjusted to allow encoding any smaller analog voltage span to the full 8 bits of resolution. [9]

Features include:

- 1-Compatible with 8080 Microprocessors
- 2-Easy interface to all microprocessors, or operates 'stand alone'
- 3-Differential analog voltage inputs
- 4-Logic inputs and outputs meet both MOS and TTL voltage level specifications
- 5-Works with 2.5V (LM336) Voltage Reference
- 6-On-chip clock generator
- 7-0V to 5V analog input voltage range with single 5V supply.
- 8-No zero adjust required.
- 9-Operates ratiometrically or with 5V DC, 2.5V DC, or analog span adjusted voltage reference.

Although, the integrated circuit is designed for computer and microprocessor interfacing, the project design allows simple interface with a common 7-segment display. In fact, the integrated circuit is the heart of the altogether circuit.

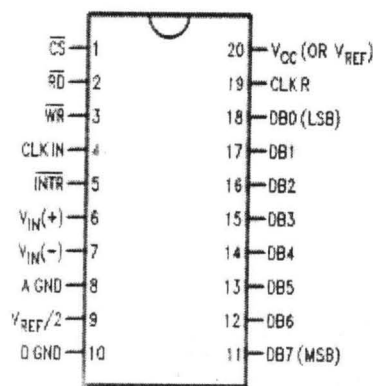

Fig. 2.3 Pin Layout of the ADC0804

2.4.2.1 Pin Number Description

- 1- CS - Chip Select (Active Low)
- 2- RD - Read (Active Low)
- 3- WR - Write (Active Low)
- 4- CLK IN - Clock IN
- 5- [INTR - Interrupt (Active Low)
- 6- Vin+ - Analog Voltage Input
- 7- Vin- - Analog Voltage Input
- 8- AGND - Analog Ground
- 9- Vref/2 - Voltage Reference / 2
- 10- DGND - Digital Ground
- 11- DB7 - Data Bit 7 (MSB)
- 12- DB6 - Data Bit 6
- 13- DB5 - Data Bit 5
- 14- DB4 - Data Bit 4
- 15- DB3 - Data Bit 3
- 16- DB2 - Data Bit 2
- 17- DB1 - Data Bit 1
- 18- DB0 - Data Bit 0 (LSB)
- 19- CLKR - Clock Reset
- 20- Vcc - Positive Supply or Vref

2.4.2.3 40103B

The 40103B is an 8-stage binary synchronous down counter with a single output which is active when the internal count is zero. The integrated circuit has control inputs for enabling

or disabling the clock, for clearing the counter to its maximum count, and for presetting the counter either synchronously or asynchronously. All control inputs and the CARRY-OUT/ZERO-DETECT OUTPUT ARE ACTIVE-LOW logic. In normal operation, the counter is decremented by one count on each positive transition of the CLOCK. Counting is inhibited when the CARRY-IN/COUNTER ENABLE (CI/CE) input is high. The CARRY OUT/ZERO-DETECTOR (CO/ZD) output goes low when the count reaches zero if the CI/CE input is low, and remains low for one full clock period.

When the SYNCHRONOUS PRESET_ENABLE (SPE) input is low, data at the JAM input is clocked into the counter on the next clock regardless of the state of the CI/CE input. When the ASYNCHRONOUS PRESET-ENABLE (APE) input is low, data at the JAM inputs is asynchronously forced into the counter regardless of the state of the SPE, CI/CE, or CLOCK inputs. JAM inputs J0-J7 represent single 8-bit binary word. When the CLEAR input is low, the counter is asynchronously cleared to its maximum count binary code 255. [9]

If all control inputs except CI/CE are high at the time of zero count, the counters will jump to the maximum count, giving a counting sequence of 256 clock pulses long. This causes the CO/ZD output to go low to enable the clock on each succeeding clock pulse.

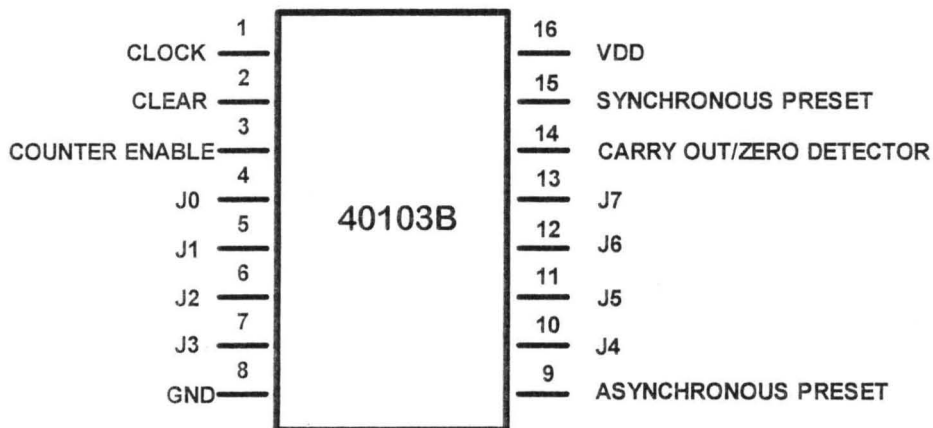

Fig. 2.4 Pin configuration of the 40103B

2.4.2.4 4081B

The 4081B is also a CMOS integrated circuit consisting of four independent 2-input AND gates.

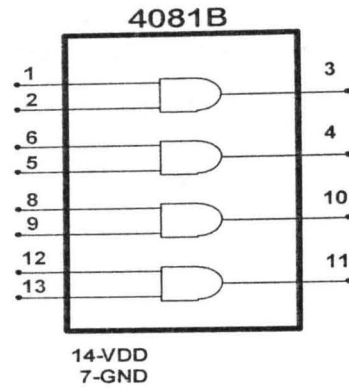

Fig. 2.5 Pin configuration of the 4081B [9]

2.4.2.5 4069B

The 4069B is also a CMOS integrated circuit consisting of six independent NOT gates.

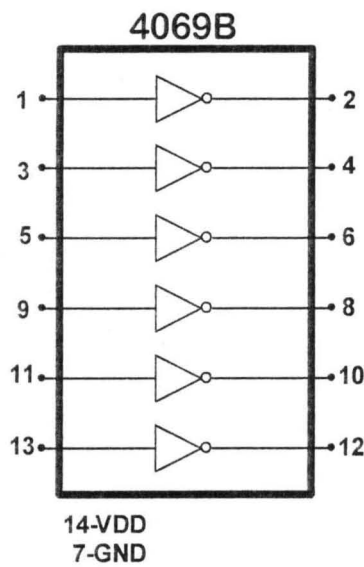

Fig. 2.6 Pin configuration of the 4069B

2.4.2.6 4518B

The 4518b integrated circuit is a dual BCD 4-stage up-counter. The counter stages are D-type flip-flops having interchangeable CLOCK and ENALE lines for incrementing on either the positive-going or negative-going transition. For single-unit operation the ENABLE input is maintained high and the counter advances on each positive-going transition of the CLOCK. The counters are cleared by high levels on their RESET lines. The counter can be cascaded in the ripple mode by connecting Q4 to the enable input of the subsequent counter while the CLOCK input of the latter is held low. This integrated circuit is used for multistage synchronous counting, multistage ripple counting, and frequency dividers. [8]

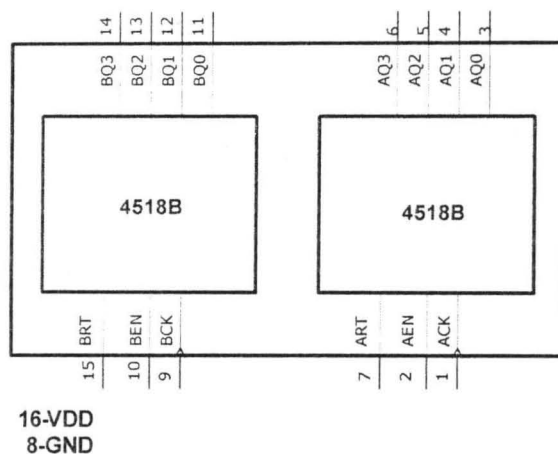

Fig. 2.7 Pin configuration of the 4518B

2.4.2.7 4511B

The 4511B is a monolithic CMOS integrated circuit available in 16-lead dual in-line plastic or ceramic package and plastic micro package. It is a BCD-to-7-segment latch decoder drivers constructed with COS/MOS logic and n-p-n bipolar transistor output devices on a single monolithic structure. This device combines the low quiescent power dissipation and high noise immunity features of COS/MOS with n-p-n bipolar output transistors capable of sourcing up to 25 mA. This capability allows the 4511B to drive LED's and other displays

directly. Lamp Test (LT), Blanking (BL), and Latch Enable or Strobe inputs are provided to test the display, shut off or intensity-modulate it, and store or strobe a BCD code, respectively.

[8]

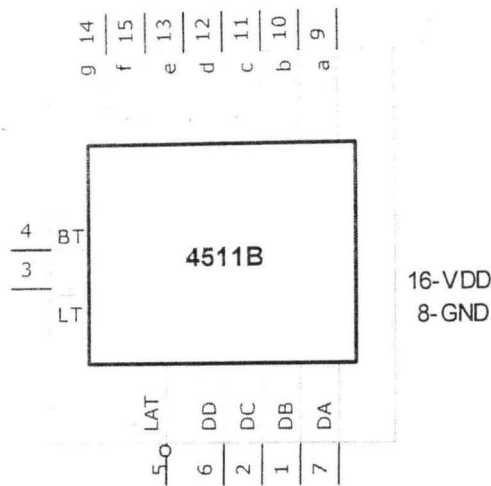

Fig. 2.8 Pin configuration of the 4511B

LE	BI	LT	D	C	B	A	a	b	c	d	e	f	g	Display
X	X	0	X	X	X	X	1	1	1	1	1	1	1	8
X	0	1	X	X	X	X	0	0	0	0	0	0	0	Blank
0	1	1	0	0	0	0	1	1	1	1	1	1	0	0
0	1	1	0	0	0	1	0	1	1	0	0	0	0	1
0	1	1	0	0	1	0	1	1	0	1	1	0	1	2
0	1	1	0	0	1	1	1	1	1	1	0	0	1	3
0	1	1	0	1	0	0	0	1	1	0	0	1	1	4
0	1	1	0	1	0	1	1	0	1	1	0	1	1	5
0	1	1	0	1	1	0	0	0	1	1	1	1	1	6
0	1	1	0	1	1	1	1	1	1	0	0	0	0	7
0	1	1	1	0	0	0	1	1	1	1	1	1	1	8
0	1	1	1	0	0	1	1	1	1	0	0	1	1	9
0	1	1	1	0	1	0	0	0	0	0	0	0	0	Blank
0	1	1	1	0	1	1	0	0	0	0	0	0	0	Blank
0	1	1	1	1	0	0	0	0	0	0	0	0	0	Blank
0	1	1	1	1	0	1	0	0	0	0	0	0	0	Blank
0	1	1	1	1	1	0	0	0	0	0	0	0	0	Blank
0	1	1	1	1	1	1	0	0	0	0	0	0	0	Blank
1	1	1	X	X	X	X								

Truth table of the 4511B [8]

2.4.2.3 4017B

The 4017B is a CMOS decade counter with ten outputs. It is designed to give a positive pulse or output at each of the output pins- in turn. So the first output pin will give an output

signal and switch off, followed by the second and so on. In order to do this pin 14 has to be provided with an astable signal or clock signal. Pins 15, 13, and 12 are reset, clock enable, and carry out. [8]

2.4.2.9 4060B

The 4060 is a high speed CMOS 14- STAGE BINARY COUNTER/OSCILLATOR fabricated in silicon gate C2MOS technology. The oscillator configuration allows design of either RC or crystal oscillator circuits. A high level on the CLEAR accomplishes the reset function, i.e. all counter outputs are made low and the oscillator is disabled. A negative transition on the clock input increments the counter. Ten kinds of divided output are provided; 4 to 10 and 12 to 14 stage inclusive. The maximum division available at Q12 is 1/16384 f oscillator. The $\emptyset 1$ input and the CLEAR input are equipped with protection circuits against static discharge and transient excess voltage.

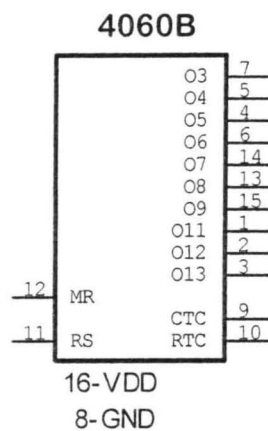

Fig. 2.9 Pin configuration of the 4060B

PIN No	SYMBOL	NAME AND FUNCTION
1, 2, 3	Q12 to Q14	Counter Outputs
7, 5, 4, 6, 14, 13, 15	Q4 to Q10	Counter Outputs
9	$\emptyset O$	External Capacitor Connection
10	$\emptyset O$	External Resistor Connection
11	$\emptyset I$	Clock Input/Oscillator Pin
12	CLEAR	Master Reset
8	GND	Ground (0V)
16	V _{cc}	Positive Supply Voltage

Pin assignment of 4060B [9]

From the manufacturer's data sheet the main frequency (f_m) output of the integrated circuit before division is given by:

$$f_m = \frac{1}{2.3R_{TC}C_{TC}}$$

While the value of resistor R_S must be satisfied by the following relationship:

$$10R_{TC} \geq R_S \geq 2R_{TC}$$

The frequency of a particular output terminal is given as follows:

$$f_{O_x} = \frac{f_m}{2^x}$$

x is the output number mark.

2.4.2.10 40174B

The 40174B is a CMOS integrated circuit consisting of six identical D type flip-flop having independent DATA inputs. The Clock and CLEAR (pins 9 and 1 respectively) inputs are common to all six units. Data is transferred to the Q outputs on the positive-going transition of the clock pulse. All six flip-flops are simultaneously reset by a low level on the CLEAR input.[8]

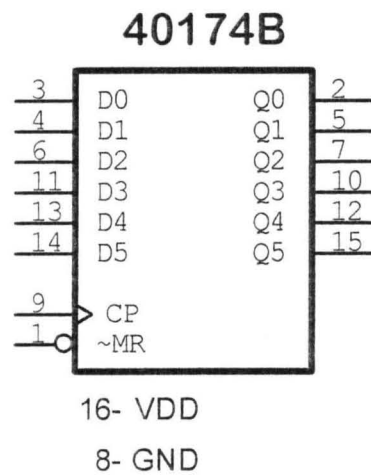





Fig. 2.10 Pin assignment of 40174B

TRUTH TABLE FOR 1 OF 6 FLIP-FLOPS

CLOCK	INPUTS		OUTPUT
	DATA	CLEAR	Q
	0	1	0
	1	1	1
	X	1	NC
X	X	0	0

1 = High Level X = Don't Care
 0 = Low Level NC = No Change

Truth table of the 40174B

2.4.2.11 2SC945 Transistor

The 2SC945 is a very common general purpose NPN transistor with an average current gain of 120 and maximum collector current of 100mV. It serves applications such as switching and audio amplifier. [9]

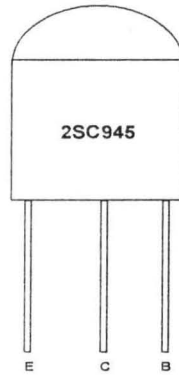

Fig. 2.11 Pin configuration of the 2SC945

CHAPTER THREE

3.0 CIRCUIT DESIGN ANALYSIS

The Circuit Design Analysis embodies the following parts:

- Power unit
- Temperature sensing unit
- Analogue to Digital Converter unit
- Output calibrating unit
- Display unit
- Speed regulating/switching unit

3.1 POWER UNIT

The power unit consist of a 24V step-down transformer power supply and it is designed to provide both 5 and 12 regulated voltages using 7805 and 7812 positive voltage regulator respectively. The 5V supplies power for almost all the units of the circuit except the relay circuit which depends on 12V power supply.

The power circuit set-up is quite simple and centered on bridge rectifier type. The 24V from the step-down transformer is converted from AC to DC and then filtered through a large capacitor (2200uF) for smoothening before connecting to the two voltage regulators which provide the necessary voltages. The involved transformer rating is 24V 500mA. The circuit can

$$power = VI$$

delivered power of about:

$$power = 12 \times 500 \times 10^{-3}$$

$$power = 6W$$

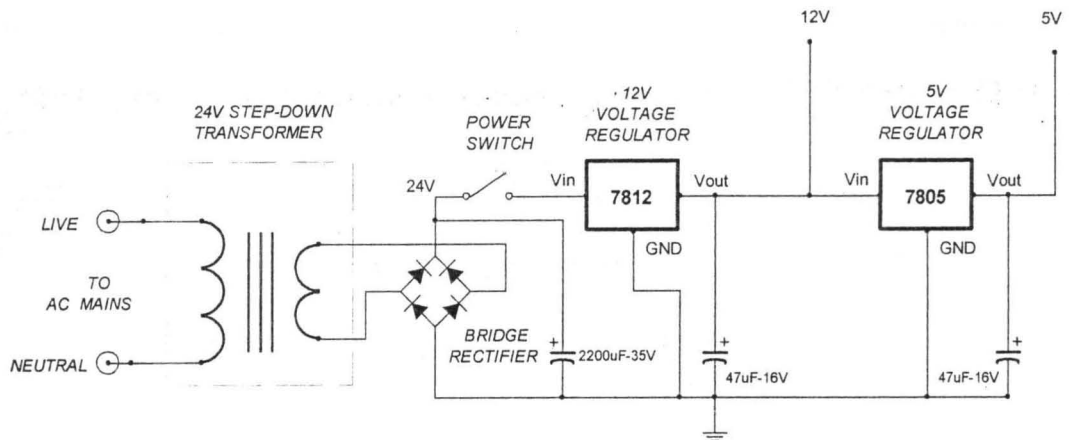

Fig3.1 The power unit

3.2 TEMPERATURE SENSING UNIT

As early stated, this unit serves as the main input of the altogether circuit. The active device is the LM35 linear temperature sensor. It is designed to convert temperature, a physical quantity, into analogue electronic form which is of great importance to the other part of the circuit.

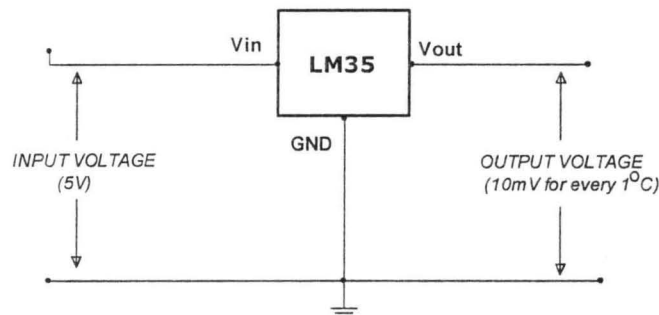

Fig 3.2 Temperature sensor Circuit

The above circuit shows the voltage connection of the temperature sensor. It is supplied with a 5V. The output produces 10mV for every 1°C temperature (10.0 mV/°C scale factor) detected by the sensor. The terminal is connected to pin6 of the ADC0804.

3.3 ANALOGUE TO DIGITAL CONVERTER (ADC)

The voltage output of the temperature sensor is needed in corresponding digital format for control and display uses. The Analogue to Digital converter does the leading task.

The converter requires the circuit below with respect to its manufacturer's datasheet. Pin 6 of the integrated circuit is connected to pin 3 of the temperature sensor. Pins 11,12,13,14,15,16,17 and 18 serve as 8-bit output of the device. Pins 4 and 19 are connected to a RC circuit for internal clocking or timing.

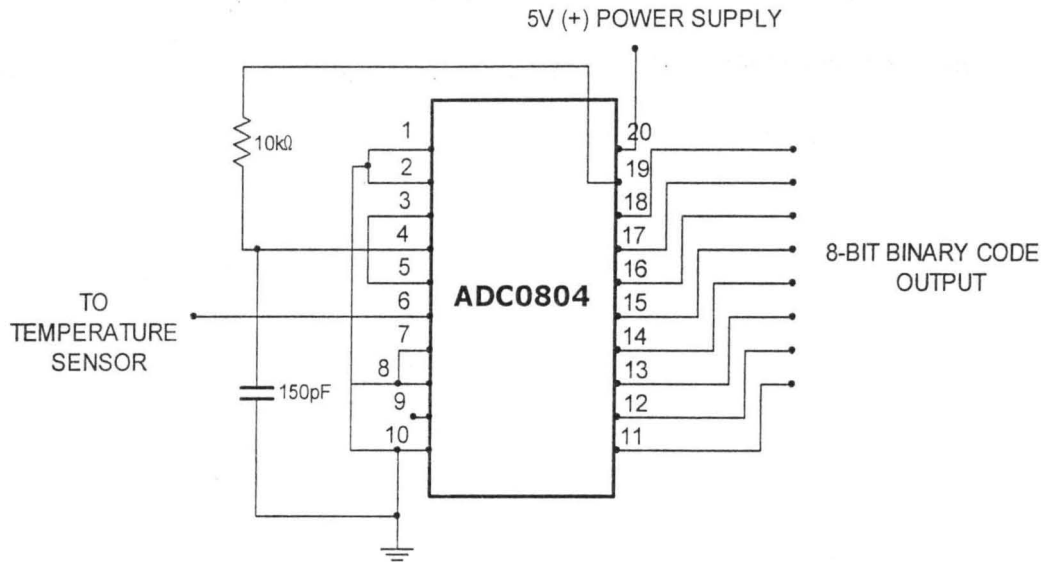

Fig 3.3 The Analogue to Digital Converter circuit

The RC circuit consists of a 10KΩ and a 150pF resistor and capacitor respectively.

The internal clocking of process in the ADC is given as:

$$f = \frac{1}{RC}$$

$$f = \frac{1}{10 \times 10^3 \times 150 \times 10^{-12}}$$

$$f = 666.7 \text{ KHz}$$

$$T = \frac{1}{f} = \frac{1}{666.7 \text{ KHz}} = 1.5 \mu s$$

$$T = 1.5 \mu s$$

The result above shows that the Analogue to Digital Converter operates at a very high speed in the conversion of analogue signal to digital form.

The ADC is set to a resolution of 10mV/bit, which signifies that its output code is incremented by a digit one for every 10mV. This process allows for direct conversion of the analogue output from the temperature sensor into digital. This is because the two devices are in tune to one and the same resolution.

The table below shows the relationship between corresponding temperature, voltage, and code as concern with the analysis so far.

TEMPERATURE (°C)	VOLTAGE (mV) 10mV/°C	8-BIT BINARY CODE
0	0	00000000
3	30	00000000
28	280	00000000
45	450	00000000

Temperature-voltage-code table 1

The final output is in binary and cannot be used directly for display and control application. Therefore, an output calibrating unit is required to make the output more useful for the aim of the project.

3.4 OUTPUT CALIBRATING UNIT

This unit is designed to work along side with the display unit in converting the 8-bit binary coded output from the ADC into decade form or base10 number format for display

purpose. The unit consists of a control oscillator that reduces the sampling response or speed of the unit with respect to that of the ADC. The reduction of data conversion speed is needed to minimize switching error. It is very obvious that at relatively higher conversation speed, the fan speed regulation would not be stable.

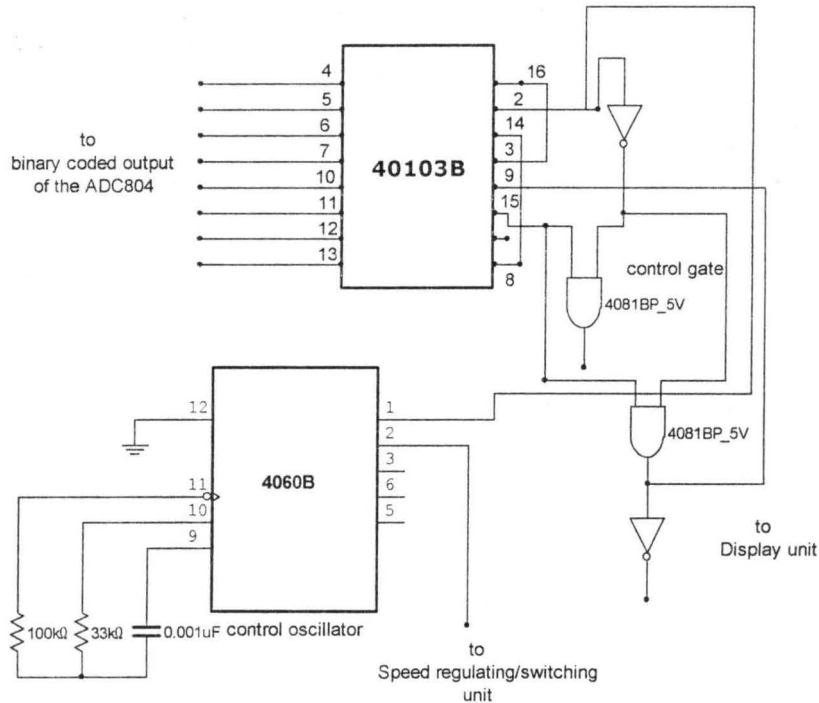

Fig3.4 The output calibrating unit

The 40103B 8-bit down binary counter is the heart of the unit. It possesses eight inputs that are connected to the corresponding digital outputs of the ADC. The integrated circuit operates with an AND-NOT gate circuit that connects the unit to the display side of the altogether circuit.

This unit simply allows the processed temperature information to be displayed on a seven segment display panel which uses 4-bit decade format. The table below shows the relationship between the temperatures at the sensor, corresponding voltage outputs from the sensor, corresponding 8-bit binary codes from the Analogue to Digital Converter (ADC), and the final result of the output calibrating unit (two 4-bit decade code at the 7-segment display).

TEMPERATURE (°C)	VOLTAGE (mV) 10mV/°C	8-BIT BINARY CODE	4-BIT DECADE CODE
0	0	00000000	0000 0000
3	30	00000000	0000 0011
28	280	00000000	0010 1000
45	450	00000000	0100 0101

Temperature-voltage-code table 2s

3.4.1 Control Oscillator

The control oscillator consists of two operational frequency outputs from pins 1 and 2. The first signal serves the output calibrating unit, while the other is used for manual fan speed regulation or switching.

Using the early stated formula in chapter 2, related to 4060B frequency outputs, the leading two frequencies can be calculated as follows:

$$R_{TC} = 33 K\Omega$$

$$C_{TC} = 0.001 \mu F$$

$$R_s = 100 K\Omega$$

$$f_m = \frac{1}{2.3 R_{TC} C_{TC}} :$$

$$f_m = \frac{1}{2.3 \times 33 \times 10^3 \times 0.001 \times 10^{-6}} = 13175.2 \text{ Hz}$$

$$f_m \approx 13.2 \text{ KHz}$$

Output frequency from pin 1 whose O value is 12, of the 4060B integrated circuit is given below:

$$f_{O12} = \frac{f_m}{2^{12}}$$

$$f_{O12} = \frac{13200}{2^{12}} = 3.2 \text{ Hz}$$

$$f_{O12} = 3.2 \text{ Hz}$$

$$T_{O12} = \frac{1}{f_{O12}} = \frac{1}{3.2} = 0.31 \text{ s}$$

$$T_{O12} = 0.31 \text{ s}$$

Output frequency from pin 3 whose Q value is 13, of the 4060B integrated circuit is given below:

$$f_{O13} = \frac{f_m}{2^{13}}$$

$$f_{O13} = \frac{13200}{2^{13}} = 1.6 \text{ Hz}$$

$$f_{O13} = 1.6 \text{ Hz}$$

$$T_{O13} = \frac{1}{f_{O13}} = \frac{1}{1.6} = 0.625 \text{ s}$$

$$T_{O13} = 0.625 \text{ s}$$

3.5 DISPLAY UNIT

The display unit is merely designed to show the temperature at the sensor on a 7-segment display. This unit consists of two cascaded 4518B BCD counters, two BCD to 7-segment decoders, and two 7-segment common cathode displays. The components are connected in a conventional manner using current limiting resistors to drop suitable voltage at each segment of the involved displays. The display unit has a maximum count of 99.

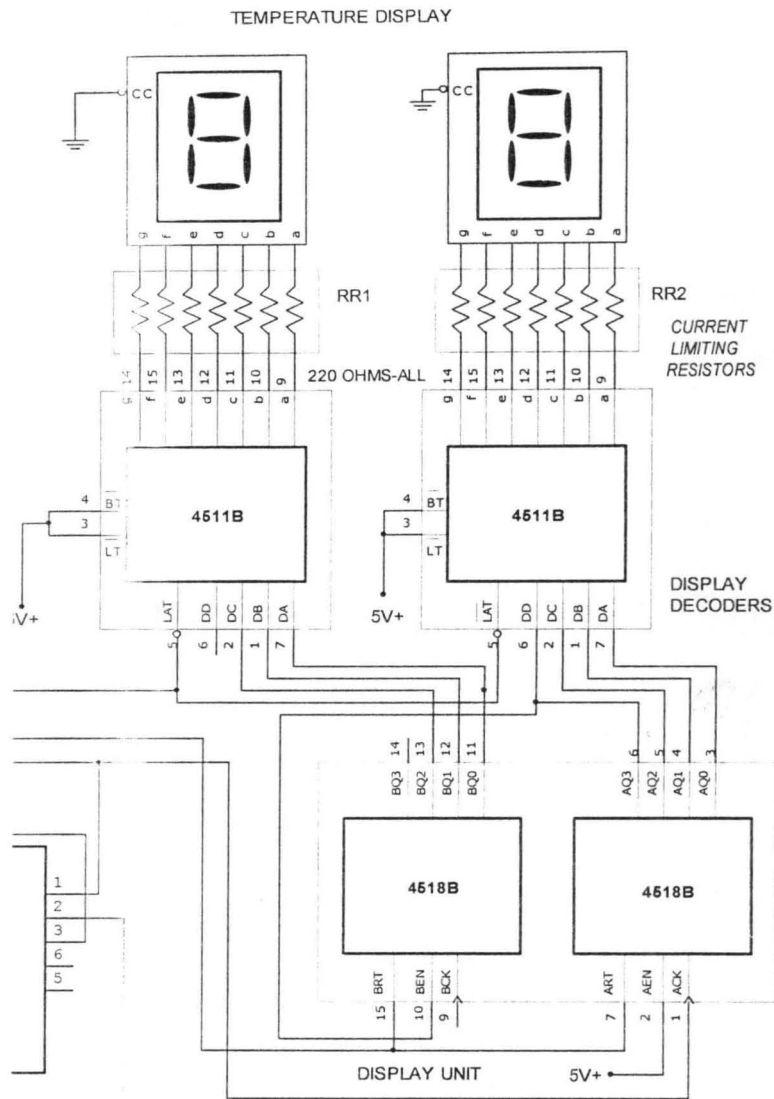

Fig.3.5 Display Unit

The table below shows the corresponding display for temperature some inputs.

TEMPERATURE (°C)	VOLTAGE (mV) 10mV/°C	8-BIT BINARY CODE	Corresponding 4-BIT DECADE CODE	TEMPERATURE DISPLAY
0	0	00000000	0000 0000	0
3	30	00000000	0000 0011	3
28	280	00000000	0010 1000	28
45	450	00000000	0100 0101	45

3.6 FAN SPEED REGULATING/SWITCHING UNIT

This unit allows the digital information from the temperature sensor to be used in regulating and controlling the speed of a fan. It is designed to respond to 27 and lower, 28-31, 32-35, and above 36°C temperature ranges for OFF, LOW, MEDIUM and HIGH speed control respectively at the fan. These ranges can be easily altered for different environments. A 3-LED display panel is incorporated into the circuit to show the speed of the fan.

The diagram below shows the elements of the unit which is sub-divided into the following smaller parts for better understanding of its whole operation:

Stepper A/latch circuit,

Switching transistor/relay circuit,

Speed indicator circuit,

Stepper B manual control, and Speed Regulation Transformer

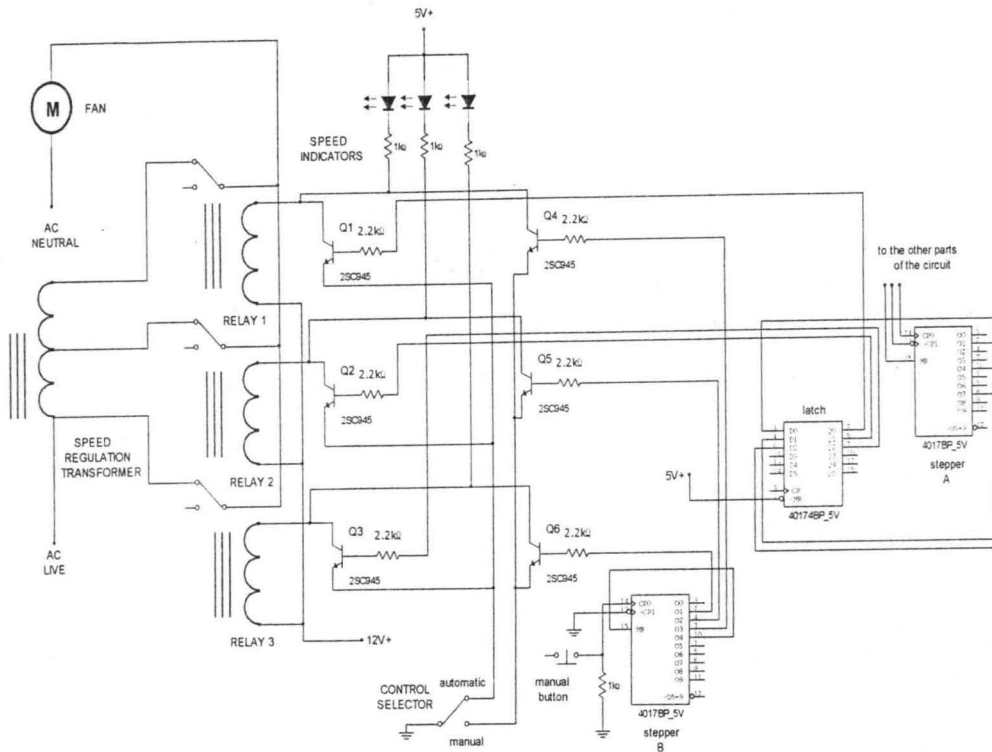

Fig3.6 The speed regulating unit

3.6.1 Stepper A/latch circuit

The unit consists of a stepper As/latch circuit that allows temperature-digital signal from the output calibrating unit to be used for setting the switching ranges of the speed regulator. The stepper is a 4017B integrated circuit. It processes the signal from the output calibrating unit through logical division which allows the ranges to be set.

The latch (40174B) serves like a memory which holds the initial result from the stepper before a new one is processed and stored. The main technical importance of the device is to fetch result from a high speed process at the stepper A-output calibrating unit circuit. There are three outputs from the latch. They are used for switching transistors of the output relays, which are connected to the speed regulation transformer or inductor.

3.6.2 Switching transistor/relay circuit

This circuit is designed to receive control signal from the latch in switching the corresponding relays. There are three relays which are controlled by three corresponding 2SC945 NPN transistors.

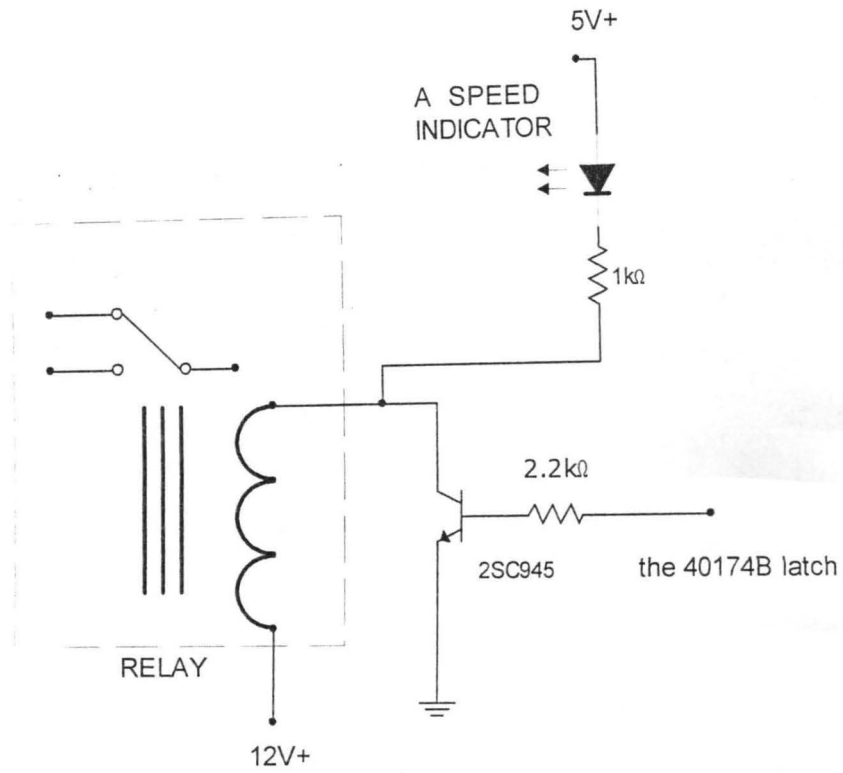

Fig3.7 A single Switching transistor/relay circuit

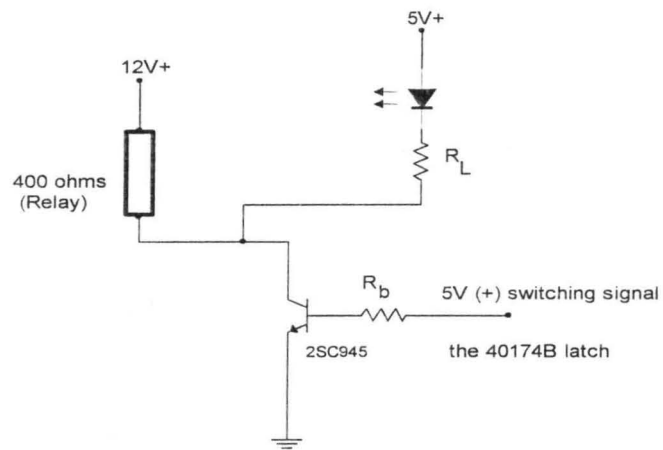

Fig. 3.8 Speed Display

The circuit analysis

The transistor circuit switches the relay on whenever the corresponding control output of the latch is logical 1 or positive 5V. Reverse is the case whenever the leading output goes low. The relay has a load of 400Ω.

Considering the ON state of the 2SC945 transistor of 120 current gain (hfe),

$$I_C = \frac{V_{cc}}{400}$$

$$I_C = \frac{12}{400} = 30mA$$

$$I_C = 30mA$$

$$I_b = \frac{I_C}{hfe}$$

$$I_b = \frac{30mA}{120} = 0.3mA$$

$$I_b = 0.3mA$$

$$R_b = \frac{5V}{I_b} = \frac{5}{0.3 \times 10^{-3}} = 16.6K\Omega$$

This calculated base resistance would not be appropriate for the base due to reasonable voltage drop at the output of latch. It is practically realized that 2.2KΩ resistor is quite suitable for the switching of the transistor. From the circuit diagram, the negative poles at the emitters of the transistors are switched by the mode control or control selector switch for enabling and disabling automatic temperature control of speed regulation.

3.6.3 Speed indicator circuit

This circuit consists of a Light Emitting Diode (LED) and a resistor. It is connected to the collector of each relay switching transistor, for showing their on state in speed regulation of the output fan.

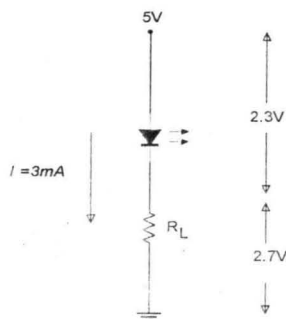

Fig3.9 A single speed indicator Circuit

The LED is rated 2.3V at 3mA. The series resistor is needed to cause suitable voltage drop across the LED.

Therefore.

$$I = 3mA$$

$$R_L = \frac{V_{RL}}{I}$$

$$R_L = \frac{(5 - 2.3)}{3 \times 10^{-3}} = 900\Omega \quad (\text{Equations from ohms law})$$

$$R_L = 900\Omega$$

A 1000Ω resistor is more practically preferable due to availability.

3.6.4 Stepper B manual control

Stepper B is also a 4017B integrated circuit. It is designed for manually selecting or controlling the speed regulation. To activate this operation, the control mode or selection switch must be at "manual".

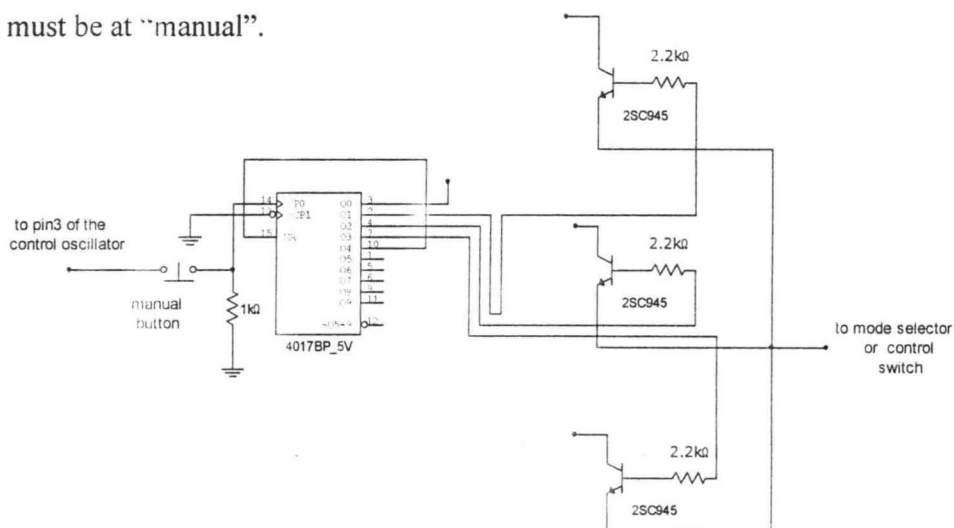

Fig3.10 The stepper B Manual control circuit

From the above circuit diagram, note that ,whenever the manual switch is pressed the low or slow pulse from pin 3 of the oscillator is fed into pin 14 (clock) of the 4017B (the stepper B).Logical one is moved or stepped across pins 3, 2, 4, and 7 of the integrated circuit. These pins switch on corresponding transistors which are connected to the output speed regulation transformer or inductor for selecting a particular speed for the fan.

Moreover, the mode selector/mode control switch is simply designed one of two sets of three transistors through their emitters to control speed regulation of a connected fan through the temperature control technique or manually by pressing the manual control switch or button.

3.6.5 Speed Regulation Transformer

The operation of this transformer is centered on the inductive reactance of an inductor in an AC circuit.

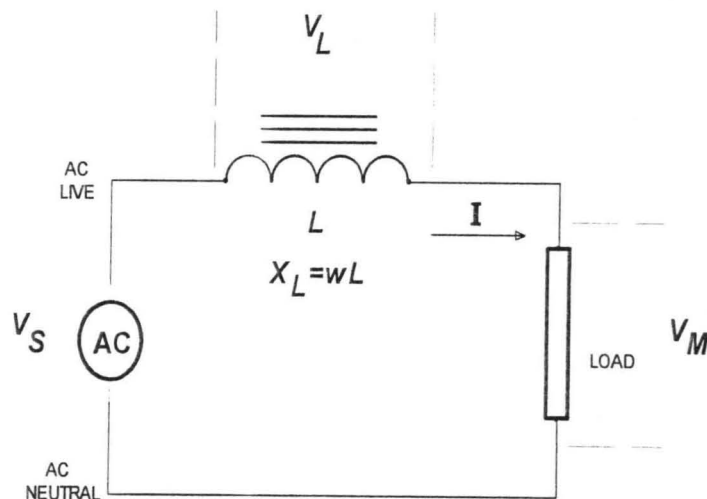

Fig 3.11 An inductive AC circuit

$$X_L = \omega L = 2\pi fL$$

$$V_L = I \times X_L$$

$$V_s = V_L + V_M$$

In the diagram and equations above, the more the series inductance the lower is I (the current flowing in the circuit) the higher is V_L , and lower is V_M (the voltage across the load).

The speed regulation transformer is merely a series tapped inductor which is connected in series with the fan (load). A particular tap is selected on the inductor by the relay to put a particular inductive reactance in series with the fan so as to cause a reasonable drop in voltage and speed.

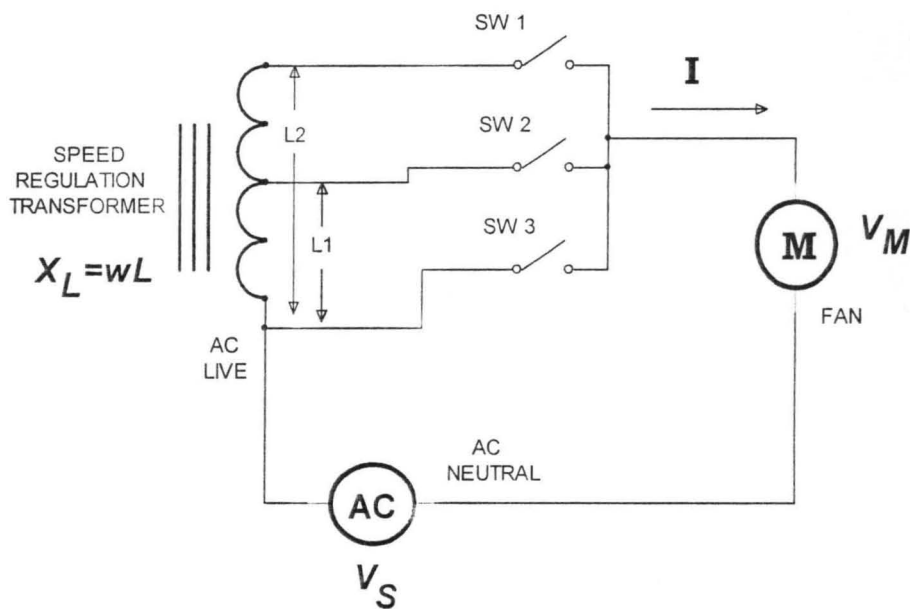

Fig.3.12 Simplified speed regulation circuit

Switches SW1, SW2, and SW3 represent switching relays-in which only one of them is switched on at a particular time. Whenever the three switches are off or unselected, I and V_M are zero, the fan is off. When only SW1 is on, L2 is put in series with the fan. The inductive

reactance of the inductor produces a V_M lower than V_s (which ought to be 220V) due to reduced current flow.

Moreover, when only SW2 is selected, L1 is put in series with the fan. It is quite obvious that L1 is greater than L2. Therefore; a lower inductive reactance is in the circuit as compare to the early case. Now, I and V_M are relatively higher and resulting into increase in the speed of the fan. Switch SW3 provides the highest speed for the fan. In this case, the fan is connected directly to the AC mains ($V_M = V_s$) with zero series inductive reactance. The load can be a ceiling or standing fan. The full test is described in the following chapter.

CHAPTER FOUR

4.0 CONSTRUCTION, TESTING AND DISCUSSION OF RESULTS

4.1 CIRCUIT CONSTRUCTION

This part of the project involved practical exercise of converting the circuit diagram on the paper into a real working hardware. The first part entailed verifying the workability of some parts and components of the involved circuit on the bread board. It was a temporary circuit connection.

The main construction was done on a Vero board. The involved electronic components were carefully connected together under the guide of the circuit diagram. The breaking down of the complete circuit during the design analysis, in the early chapter, was of great importance in the construction. Each unit circuit was executed one after the other. After which all the units were joined together as a single working construction.

The power supply unit was quite delicate during the construction- it was made with great care. After the complete construction, the power unit was properly checked for short circuit and unwanted bridges.

The circuit's construction involves the following materials and tools:-

- Soldering iron
- Soldering lead
- Jumper wires
- Integrated circuit sockets
- Cutting knife
- Razor blade
- Pliers
- Pair of Scissor
- Digital multimeter

4.1.1 Casing Construction

The casing of the project was made with cheap plastic material. The choice of the material allowed holes and openings, for external parts of the circuit, to be easily made on the casing.

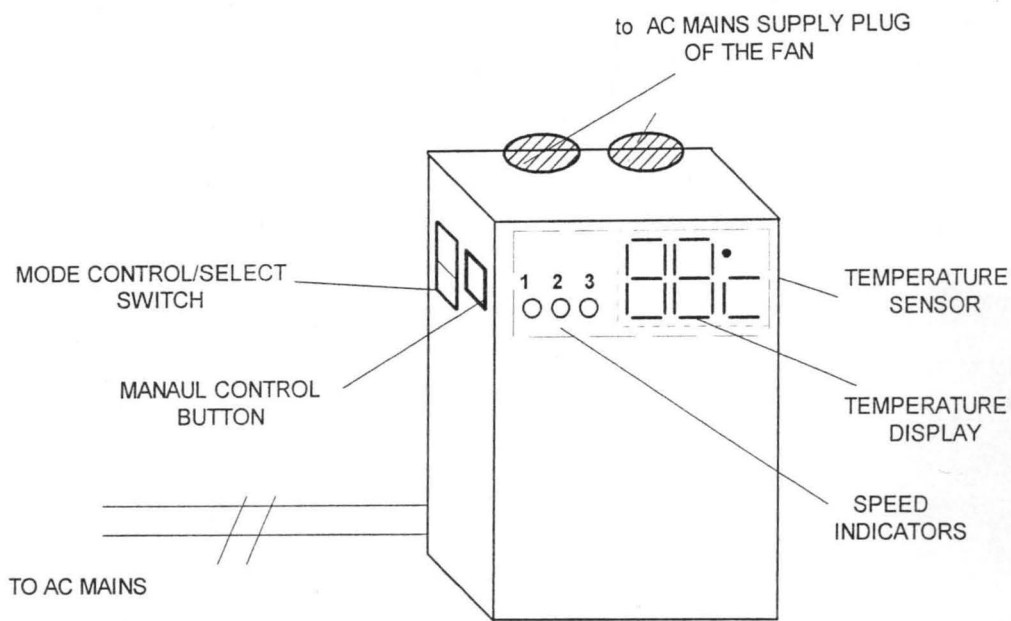

Fig.4.1 The casing

4.2 TESTING

The diagrams below show the test set-up and test materials for the project.

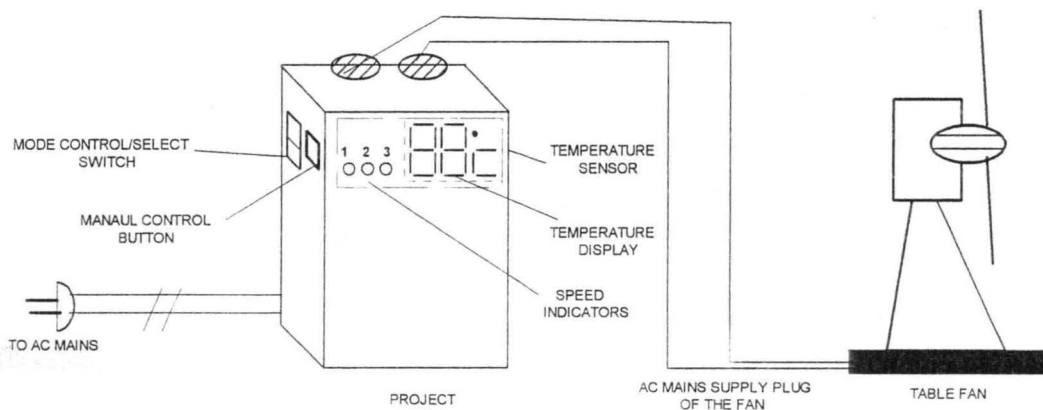

Fig. 4.2 Testing

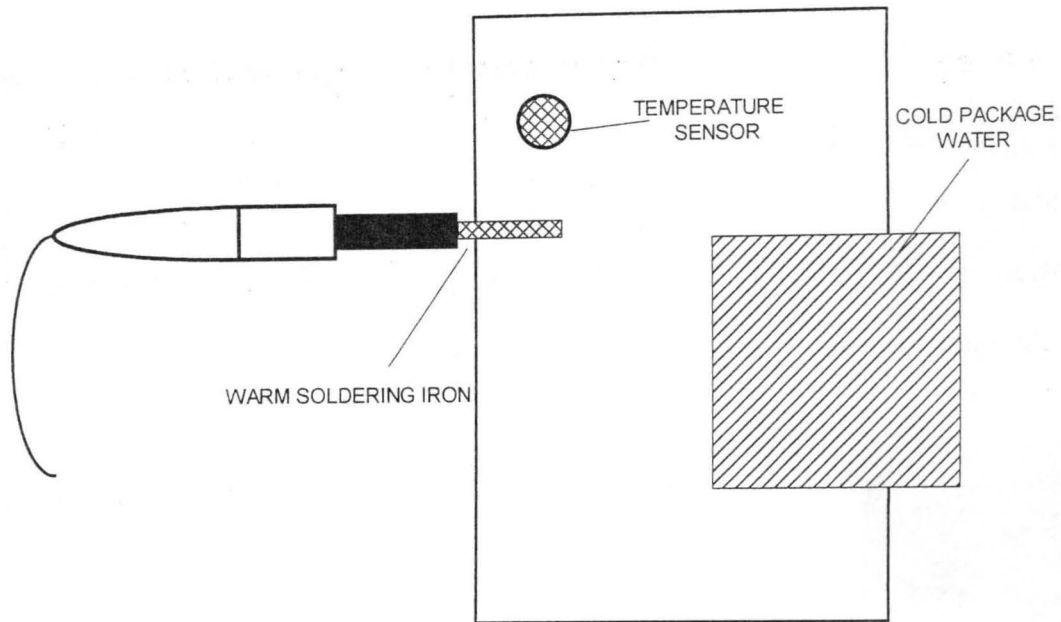

Figure 4.3 Testing Process

Firstly, the device was plugged to the AC mains. The temperature reading showed error reading after about 10 seconds the acute temperature of the room was correctly shown on the display. The temperature reading was 29°C. The mode control or select switch made pushed up for automatic control. The second Light Emitting Diode (LED) of the speed indicator was ON. The speed of the fan was moderate.

A warm soldering iron was placed close to the temperature sensor. The temperature display/reading did not respond quickly to the change. It took some time before the temperature reading increased to about 31 then 39 and higher to 48°C or a little beyond. At that moment the second LED of the speed indicator was OFF and the third went ON. The fan was very fast as compare to the initial speed. The soldering iron was taken away from the temperature sensor. The temperature was watched to reduce gradually.

As the temperature was dropping close and around 36°C, the second and third LEDs of the speed selector interchanged giving a corresponding speed alteration of the fan. The speed was set at the middle around 32°C temperature reading.

Moreover, as the temperature was dropping below 32°C, the first and second LEDs of the speed selector interchanged giving a corresponding speed alteration of the fan. The speed was set at the lowest around 28°C temperature reading.

When the cold water was placed close to the temperature sensor in reducing its temperature far below 28°C, the device slowly responded in switching off the fan. At that moment all the LEDs of the speed indicator went completely off.

In addition, the manual control button was tested by pressing the mode control switch down to "manual". The speed of the fan altered as the manual button was held pressed. The speed indicator showed the changes.

4.3 RESULT DISCUSSION

The testing went according to the aims of the work. The temperature ranges for regulating the speed of the fan were successfully established. The temperature response is made quite slow to remove switching errors of the involved relays. Even, in reality, the temperature of a normal environment increases and decreases quite slowly. Therefore, during the test, the slow response of the device to temperature changes would be unnoticed in a real situation because the temperature changes would not be rapid like the ones caused by the soldering iron and the cold package water.

CHAPTER FIVE

5.0 CONCLUSION AND RECOMMENDATIONS

5.1 CONCLUSION

The project simply and successfully demonstrated the significance of modern integrated circuits or generally electronics in control. The project shows that temperature can be used to alter the speed of a fan so as to regulate the temperature of a room.

The project really exposed me to the actual applications of electronic components. Moreover, due to the simplicity of the involved design, the project can be easily modified into full scale commercial production at an economical cost.

5.2 RECOMMENDATIONS

- 1) The project could be designed to control multiple fans (loads).
- 2) Semiconductor switching devices such as Silicon controlled rectifier (SCR) could be use instead of the relay.
- 3) A Remote control feature could be added to the design
- 4) More compact and advance integrated circuits could replace the ones in use for better performance.
- 5) Greater switching speeds could be used instead of three for better temperature control.
- 6) An alarm could be incorporated into the design to alert for unusual high temperature-serving like a fire alarm.

REFERENCES

- [1] Googl.com word web Dictionary
- [2] Kittel, Charles; Kroemer, Herbert, Thermal physics. Second edition, W. H. Freeman and Company, New York, 1980, pp. 462
- [3] <http://en.wikipedia.org/wiki/Thermometer>
- [4] Google.com.fan speed control is cool-maxim/Dallas.file//D:/1784htm
- [5] National Semiconductor integrated circuit temperature sensor data book
<http://www.national.com/mpf/lm/lm35.html/>
- [6] Scharff, Robert; Casablanca Fan Co. [1983]. The Fan Book (in English)
Reston, VA 22090: Reston Publishing Co, Inc., 128.
- [7] Art of Electronics text book by Paul Horowitz.
http://www.amazon.com/Art_Eletronics_Paul/
- [8] Data sheet Search System [online]; c 2006 Available at:
<http://www.alldatasheet.com>
- [9] Engr Shehu and S. Zubair lecture note on industrial electronic ECE 529.
August 2008, p.5-15
- [10] Theraja B.L., Theraja A.K., A test book of electrical Technology, Revised 24th Ed.
Chand & company Ltd, New Delhi. 2005. p.1122-1124

