

**DESIGN AND CONSTRUCTION OF A 20W
RECHARGEABLE FLUORESCENT LAMP WITH
REMOTE CONTROL.**

BY

OTARU O LABRAN.

2001/ 12094EE.

**DEPARTMENT OF ELECTRICAL AND
COMPUTER ENGINEERING**

FEDERAL UNIVERSITY OF TECHNOLOGY

MINNA, NIGER STATE

NOVEMBER, 2007

DECLARATION

I (Otaru O. Labran), declare that this work was done by me and has never been presented elsewhere for the award of a degree. I also hereby relinquish the copyright to the Federal University of Technology, Minna.

Otaru O. Labran
Name of student

.....
(Signature and date)

Eng'r. J.G. Kolo
Name of supervisor

.....
(Signature and date)

Eng'r. M.D Abdullahi
Name of H.O.D

.....
(Signature and Date)

.....
Name of External Examiner

.....
(Signature and Date)

DEDICATION

I dedicated this project to Almighty Allah (The all Knowing).

ACKNOWLEDGEMENT

I wish to express my sincere gratitude to Allah (SWT) for seeing me through this project. My special thanks to my parents: Mr. and Mrs. Otaru for their patience, sacrifice and understanding throughout my stay in the University. May GOD bless you.

To the head of department: Eng. M D Abdullahi for his support to see us through the course of our studies. My special thanks goes to my able supervisor Eng'r. J G.Kolo for his initiative, constructive criticism and general support particularly for making this project work successfully.

The work will not be completed without mentioning the tremendous support and encouragement from my sisters: Mrs. Rekiyat Abdulsalam, Mrs. Kulu Ogirima, Mrs. Katetrine Onotu and Miss. Otaru Fatimat for their moral support both in cash and kind. May GOD bless you all.

My gratitude to my able brothers and other sisters of mine: Eng. Yakini, Dr dahiru, Eco Nusa, Eng. Hakeem, senator Idris, Eco Sanusi, Hamzat (AKA chairman), Mrs Aishat, Mrs. Sefiyat, Miss lukayat, Miss. Simbiyat and Kuburat. For their kind gesture. May GOD bless all.

To my friend: Abu Micheal (soul friend) AKA Mikotinamide Adeniye Dianuclotide, Eng. John, Don Charlse (Onipe), Ola, Abu (temper), Eng. Usman (supply) and to all other friends too numerous to mention.

My special and profound gratitude goes to Lizzy(Anavami). I really felt your compassion through out my stay in the University .May GOD blessing be bestowed upon you.

ABSTRACT

Due to interruptive nature of electricity supply in Nigeria today and high cost of procuring stand by generating set, it became necessary to look for alternative methods of generating electricity for domestic use.

The purpose of this work is to develop a DC-AC inverter and charger units as an alternative to the use of generating set using a remote control because of its low cost, maintenance free nature and it make life simpler for the handicaps and the average individual alike.

The low power inverter and charger was design using Transistor as the main inverter switching components. It is purely a sine wave inverter. The inverter/charger can power fluorescent lamp with a remote control from a 9V battery.

The successful implementation of this project involved the careful plan and layout of the circuit components such that troubleshooting and repairs could be carried out with relative ease.

TABLE OF CONTENT

| Title | Page |
|---|------|
| Declaration | ii |
| Dedication | iii |
| Acknowledgement | iv |
| Abstract | v |
| Table of Content | vi |
| CHAPTER ONE | |
| 1.0 Introduction | 1 |
| 1.1 Aim and Objective | 2 |
| 1.2 Structure of the Circuitry | 3 |
| 1.2.1 Charger Unit | 3 |
| 1.2.2 Battery | 3 |
| 1.2.3 Inverter | 4 |
| 1.2.4 IR Transmitter and Receiver | 4 |
| 1.3 Project Outline | 4 |
| CHAPTER TWO | |
| 2.0 Literature Review | 6 |
| CHAPTER THREE | |
| 3.0 Project Design Details | 11 |
| 3.1 Design Details | 11 |
| 3.2 Power Supply Unit | 11 |
| 3.3 Battery Charging Unit | 13 |

| | |
|--|----|
| 3.4 Infrared Remote Control | 17 |
| 3.4.1 Transmitter Unit | 17 |
| 3.4.2 Receiver Unit | 19 |
| 3.5 System Control Unit | 20 |
| 3.6 High Frequency Inverter | 21 |
| CHAPTER FOUR | |
| 4.0 Construction, Testing and Result | 25 |
| 4.1 Construction | 25 |
| 4.2 Component Layout | 25 |
| 4.3 Hardware Construction | 26 |
| 4.3.1 Soldering | 26 |
| 4.3.2 Test and Analysis | 26 |
| 4.3.3 Tools Used | 27 |
| 4.3.4 Packaging | 28 |
| CHAPTER FIVE | |
| 5.0 Conclusion and Recommendation | 29 |
| 5.1 Conclusion | 29 |
| 5.2 Recommendation | 30 |
| REFERENCES | 31 |

CHAPTER ONE

1.0 INTRODUCTION

Electricity is the most convenient source of Energy for use in all aspect of economic. It can be quickly and efficiently transmitted over long distance, and can easily be converted from one form of energy to another form. It is also used to power residential equipment such as Electric cookers, room heater, radio, TV set and some other office equipments.

Some equipment and machine have greater need for quality and reliable power supply. Power interruption has let to delayed or stoppage of some industrial processes, death of people in hospitals. Vital and sensitive equipment both in offices and at home can also be damaged due to power outages.

However, some have turned to generating sets to provide alternative means of generating AC mains. The generating sets has some disadvantages, such as noise pollution, Air pollution and the need to be buying fuel which is quite expensive nowadays.

Therefore a better alternative means of power supply to electrically drive industrial machine, commercial and residential equipment is needed.

For the physically handicapped, some of the locations of light switches and their height present a real hindrance to their mobility in the home.

Also, an individual may want to do away with the inconvenience of getting up and walk across a room to switch off a light and then walk back to bed before retiring to sleep. Though bed switches have taken care of this inconvenience to some extent, the hazard caused by damaged cables is a potent threat of an individual's well being.

As a result, it would be convenient for them to operate the switch from a distance. The remote controlled light switch solve this problems, as it enables the individual to switch a light ON or OFF from a distance of about 10m.

This is the reason why 20watt Rechargeable Fluorescent Lamp with Remote Control was developed to ensure reliable power supply.

In this project, the system design is the type that supplies power to the fluorescent lamp when there is a failure from the mains. 6VDC battery is used to supply the inverter system, with the required energy which is then transformed in to AC mains, to light the fluorescent lamp.

The system that is to be designed in this project is the type of power inverter that invert 6VDC to 230VAC when there is power failure. It is design to carry fluorescent lamp conveniently since it is of low power rating. The complete circuit is made up of battery charging unit, the battery,

the inverter, the transmitter and the receiver, and the load.

1.1 PROJECT OBJECTIVE AND MOTIVATION

The aim of the project is to control the operation of light switch around the home or in an office from a specific distance.

My objective for the designing and construction of this project was the need to make life a little bit easier for the physically challenged whose height and or the location of the switches may present a real hindrance to there the home or at the offices.

1.2 STRUCTURE OF THE CIRCUITRY

Figure1 shows the block diagram of the system.

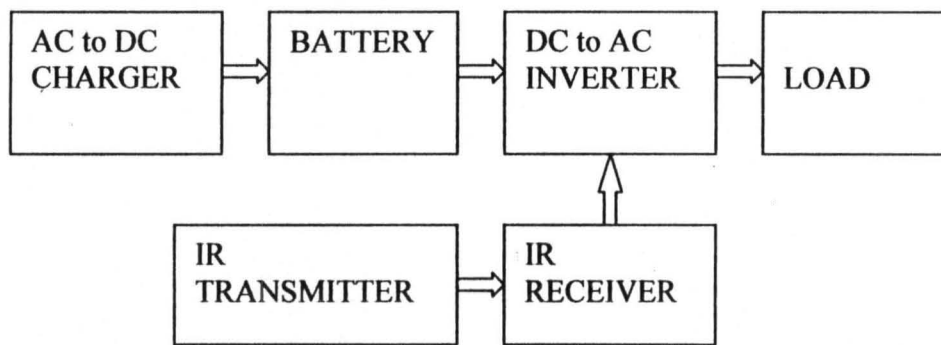

Fig 1 Block Diagram of the System.

1.2.1 CHARGER UNIT.

In this section, 220-230V AC is stepped down to 12V which is then rectified via full wave rectifier and voltage is then regulated to 6VDC.

For constant battery voltage to be maintained charging unit was incorporated.

1.2.2 BATTERY

The battery supplies the inverter with the most needed power for use by the load. The battery used in this work is a 6V, 45AH lead acid accumulator and is made up of two terminals, the positive and the negative terminals.

1.2.3 INVERTER

This is the heart of the whole design and used in inverting DC to AC, and it is the main determinant of the magnitude and frequency of the output voltage.

In case of power failure, the charged battery supplied sufficient power to the inverter to maintain its output for a specified time, until the battery is discharged to predetermined minimum voltage.

1.2.4 IR TRANSMITTER AND RECIEVER.

A hand held IR transmitter was designed to provide simple ON/OFF control for the unit. A receiver capable of detecting the generated IR beam is also needed. The transmitted IR signal is of very short duration and hence, to generate a logic level needed to pulse a toggle flip flop, the pulse has to be expanded.

The simplest pulse width expander is a monostable. In this device, a replica of the input pulse is generated at the output of the expander, the pulse width of both input and output waveforms is related by a constant that is proportional to the time constants of the delay element used.

1.3 PROJECT OUTLINE

Chapter one introduces the project and brief the existence of Electricity. And it also narrate a little how the operation should be carried out appropriately.

Chapter two review the related development and brief history related to infrared transmission and reception.

Chapter three reports the construction and testing of the entire work with appropriate circuit diagrams.

Chapter four is all about the construction, discussion of results obtained and the component layout

Chapter five is the final conclusion of the project.

CHAPTER TWO

2.0 LITERATURE REVIEW

The role of modern electric power supply cannot be over-emphasized since there is need for a reliable power supply. Research has been going on to device means whereby there will be no interruption in the power supply.

The fundamental of electrical power engineering was laid as far back as the middle of the 19th century in 1831, when the English scientist Michael faraday [1] discovered the phenomenon of electromagnetic induction. Further studies of interaction between electric current conductors and electromagnetic field led to the invention of an electric generator which converts the mechanical energy into electric energy.

The first inverter circuit was developed by an American company called the HEART INTERFACE in the year 1983.[2]

In 1984, there was an improvement in the inverter technology as the MOSFET was introduced to make the design smaller, and to switch larger current.

An inverter designed for future energy challenge by some student; joy Mazumda, duy biu , Nancy saidhana, seve pugh and Bassen Khury[3] from college of engineering and computer science , University of central florida. In their report dated 15th June 2001, a design of high power density of 10KW inverter circuit which was presented for conversion of energy from DC fuels cells to AC power to be used mainly for domestic utilities. The configuration was achieved using a high frequency DC push pull converter at the input side followed by a full bridge inverter and a low power filter at the output side. Due to the

simplified power stage and the application of the (BSP) based sinusoidal pulse width modulation technique, output voltage total harmonic distortion (THD) is reduced and a relatively smaller overall inverter size is achieved. The practical circuit operation from a 48VDC fuel cell input and output a regulated 120VAC, 60HZ sinusoidal voltage having 3-wire configuration. A low power inverter has been redesigned tested and prototypes to deliver a 1.5KW load.

There are also project done by some of the students of this department, the construction of 500VA inverter with an astable mode for signal generated, [4] TTI dual JK flip flop for pulse width modulation and frequency division. The deficiency of the work is the use of the TLL JK flip flop, which consumes much power with less efficiency. [5] And also the use of CD4047IC is a stable mode to deliver currents to the transistor.

The inverter/charger is a system that ensures continuous supply of electrical power when there is power outage, by conversion of DC to AC drawn from secondary cell.

The first remote control, called "Lazy Bones" was developed in 1950 by Zenith Electronics corporation (known as Zenith Radio Corporation)[6]. Lazy Bones used a cable that ran from the device, then a TV set, to the viewer. A motor in the TV set operated the tuner through the remote control.

By pushing button on the remote control, viewers rotated the tuner clockwise or counterclockwise, depending on whether they wanted to change the channel to a higher or lower number. The remote control included buttons that tuned the TV on and off. Although customers liked having remote control of there television, they complained that people tripped over the unsightly cable that meandered across the living room floor.

Zenith engineer Eugene Polley invented the “Flashmatic [7] “ which represented the industry ‘s first wireless TV remote introduce in 1955, Flashmatic operated by means of four photo cells, one in each corner of the TV screen. The viewer used a highly directional flashlight to activate the four control function, which turned the picture and sound on and off and changed channels by turning the tuner dial clockwise and counterclockwise.

While it pioneered the concept of wireless remote control, the Flashmatic had some limitations. It was a simple device that had no protection circuits and, if the TV was placed in an area in which the sun shone directly on it, the tuner might start rotating. Commander MC Donald loved the concepts proven by polley’s Flashmatic[8] and directed his engineers to develop a better remote control. First thoughts pointed to radio. But, because they travel through walls, radio waves could inadvertently control a TV set in an adjacent apartment or room.

Basically, a remote control works in the following manner; a button is pressed. This completes a specific connection which produces a Morse-code line signal specific to that button[9]. The Transistor Amplify the signal into infrared. The Sensor on the appliance detects the infrared light and react appropriately.

Zenith’s Dr Robert Adler suggest using “ultrasonic”[10] that is high frequency sound beyond the range of human hearing. He was assigned to lead a team of engineers to work on the first use of ultrasonic technology in the home as a new approach for a remote control.

The transmitter use batteries; it was built around aluminum rods that were light in weight and, when struck at one end, emitted distinctive high frequency sounds.[11] The first

such Remote control used four rods, each approximately 2-1/2 inches long: one for channel down, one for channel up, one for sound on and off, and one for on and off.

They were very carefully cut to lengths that would generate four slightly different frequencies. They were excited by a trigger mechanism – similar to the trigger of gun that stretched a spring and then released it so that a small hammer would strike the end of the aluminum rod.

The device was developed quickly, with the design phase beginning in 1955, called the “Zenith space command”, [12] the remote went into production in the fall of 1956, [12] becoming the practical wireless remote control device.

The original space command remote control was expensive because an elaborate receiver in the TV set, using six additional vacuum tubes, and was needed to pick up and process the signals. Although the remote system increased the price of the TV by about 30 percent, it was a technical success and adopted in later years by other manufacturers. [13]

In 1960s, solid-state circuitry (i.e. transistors) began to replace vacuum tubes. [14] Hand-held, battery –powered control units could now be designed to generate the inaudible sound electrically.

By the early 1980s, [15] the industry moved to infrared, remote technology. The IR remote works by using a low frequency light beam, so low that human eye cannot see it, but which can be detected by a receiver in the TV. Zenith development of cable compatible tuning, it used for infrared remotes.

Today, remote control is a standard feature on other consumer electronics products, including VCRs, cable and satellite boxes, digital video disc player and home audio receivers.

CHAPTER 3

3.0 PROJECT DESIGN DETAILS.

3.1 DESIGN DETAILS.

The rechargeable fluorescent lantern system is designed around the following under listed subsystems:

- I. Power supply unit.
- II. Battery charging unit.
- III. Infra red remote control unit.
- IV. System control unit.
- V. High frequency resonant inverter unit.

3.2 POWER SUPPLY UNIT.

The power supply is composed of a 12V 0.5A transformer, a full wave bridge rectifier and a 25V 2200 μ F smoothing capacitor.

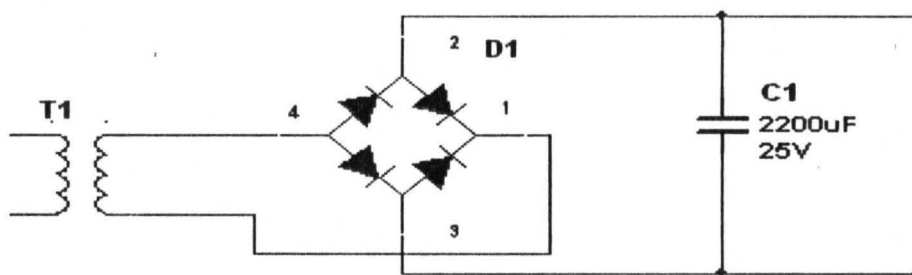

Fig 2: Bridge Rectifier circuit.

The 12V 0.5A transformer is wired to the bridge rectifier whose output is fed into a large value capacitor.

$$V_{\text{rms}}(\text{sec}) = 12\text{V}$$

$$V_f = \text{Diode forward drop} = 0.7\text{V}$$

$$V_{\text{peak}}(\text{dc}) = (12\sqrt{2} - 2V_f)\text{V}$$

$$V_{\text{peak}}(\text{dc}) = (12\sqrt{2} - 1.4)\text{V}$$

$$V_{\text{peak}}(\text{dc}) = 15.4\text{V}.$$

This pulsating DC Voltage is smoothed by a capacitance determined by the expression.

$$Q = CV = It.$$

$$CV = It.$$

$$C\Delta V = t\Delta I.$$

C = Value of the capacitance.

ΔV = Maximum available ripple on the smoothed supply.

$$t = \frac{1}{f} = \frac{1}{2} \text{ (line frequency).}$$

$$t = \frac{1}{100} = 0.01\text{s}.$$

ΔI = Maximum Current Charge – Minimum Current Charge.

Because of the low power requirement of the system, a conservative value of capacitance of $2200\mu\text{F}$ was chosen. Because the need to charge the battery when local mains is present, a changeover switch is needed. A 12V 400Ω relay was used.

3.3 BATTERY CHARGING UNIT.

The battery charging subsystem is designed around an LM317T 1.5A with three pin adjustable regulator wired as a constant Current, constant Voltage.

The LM317T regulator is wired to provide a constant charging current of approximate of 0.48A to the lead acid rechargeable battery, and it was designed as in fig3. The regulator maintains an output current determined by the value of R_2 .

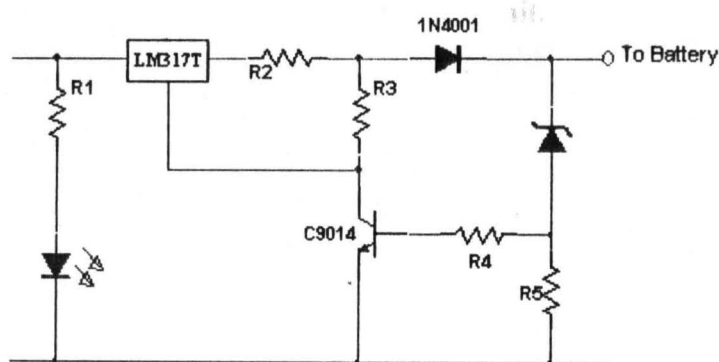

FIG:3 Battery charging unit.

$$R_1 = \frac{V_{dc} - V_{led}}{I_{led}}$$

$$V_{dc} \approx 15V.$$

$$V_{led} = 2V.$$

$$I_{led(min)} = 5mA.$$

$$I_{led(max)} = 20mA.$$

Thus,

$$R_{1(max)} = \frac{15-2}{0.005} = 2600\Omega$$

$$R_{1(min)} = \frac{15-2}{0.02} = 650\Omega$$

$$R_{1(Average)} = \frac{2600+650}{2} = 1625. = 1.6K\Omega$$

1K Ω was chosen to be the value of R₁.

To keep ΔV as low as possible, then the capacitor has to be high as possible. The upper limit imposed the maximum allowable through current that can be handled by the transformer rectifier without

$$I_{out} = \frac{V_{ref}}{R_2}$$

$$I_{out} = \frac{1.25}{R_2}$$

$$\text{The maximum charging current} = \frac{Ah}{5}.$$

$$\text{The minimum charging current} = \frac{Ah}{20}.$$

For the battery used, Ah = 4.5A.

$$\text{The maximum charging current} = \frac{4.5}{5} = 0.9A.$$

$$\text{The minimum charging current} = \frac{4.5}{20} = 0.225A.$$

$$\text{The average charging current} = \frac{0.9+0.225}{2} = 0.5625A.$$

A value of 0.463A was chosen.

Thus, $R_2 = \frac{1.25}{I_{out}}$

$$R_2 = \frac{1.25}{0.463} = 2.6998 \approx 2.7\Omega$$

0.463A yielded a value of R_2 as 2.7Ω

$R_3 = 1K\Omega$ specified by the manufacturer.

Thus, during the charging process, the battery is fed with a constant current of approximately 4.8mA. This fixed current charging prevents charging at a value of current greater than the maximum specified by the lead acid battery manufacturer.

A network comprising a NPN silicon transistor, a 6.2V Zener diode and two $2.2K\Omega$ resistor detects when the battery has reached the steady terminal (maximum programmed) Voltage.

The NPN transistor shuts the regulator down when it is fully forward biased, this happened when its V_{be} is approximately 0.7V.

From Figure 4,

$$V_a = V_{be} = V_k - V_z = V_{batt} - V_z$$

$$V_{batt} = V_{be} + V_z.$$

$$V_z = V_{batt(max)} - V_{be}.$$

$$V_z = 7 - 0.7 = 6.3V$$

At full saturation, the collector current is

$$I_c = \frac{V_{\text{batt}} + V_f}{R_c}$$

V_f is voltage across diode.

$$I_c = \frac{7 + 0.7}{1000} = 7.7\text{mA}$$

$$I_c = \beta I_b$$

$$I_b = \frac{I_c}{\beta}$$

$$I_b = \frac{0.007}{347} = 22\mu\text{A}$$

$$V_b = 0.7 = V_{be}$$

$$R_b = \frac{V_b}{I_b}$$

$$R_b = \frac{0.7}{0.000022}$$

$$R_b = 33\text{K}\Omega$$

An over drive factor of 10 was decided to reduce $V_{CE}I_C$ heating to a minimum, hence, the value of R_b was reduced by a factor of 10, yielding $2.2\text{K}\Omega$.

A maximum battery terminal potential of 6.91V was chosen, translating into Zener Voltage of 6.3V given a V_{be} as 0.7V . Initially, during the commencement of the charging process, the value of V_{batt} was low, and the transistor was cut off.

As the charging progresses, the terminal battery Voltage rises until at 6.9V, then the NPN transistor is fully forward biased. The transistor then starts shunting the adjust pin of the regulator to the ground, forcing it to reduce its output voltage to a level that just keeps the battery terminal Voltage at $(V_z + V_{be})$ volts.

A IN4001 rectifier diode prevents back discharge into the regulator with a fully charged battery.

The charger output is switched to the battery' positive terminal when AC supply is present through a 12V relay, driven from the rectifier AC from the transformer.

3.4 INFRA RED REMOTE CONTROL UNIT.

The infra red remote control unit, consist of the transmitter and the receiver unit.]

3.4.1 THE TRANSMITTER UNIT.

This is based on the simple ON – OFF generation of a constant amplitude un modulated 38KHz infra red signal. The transmitter is wired around a 555 oscillator as shown in fig4.

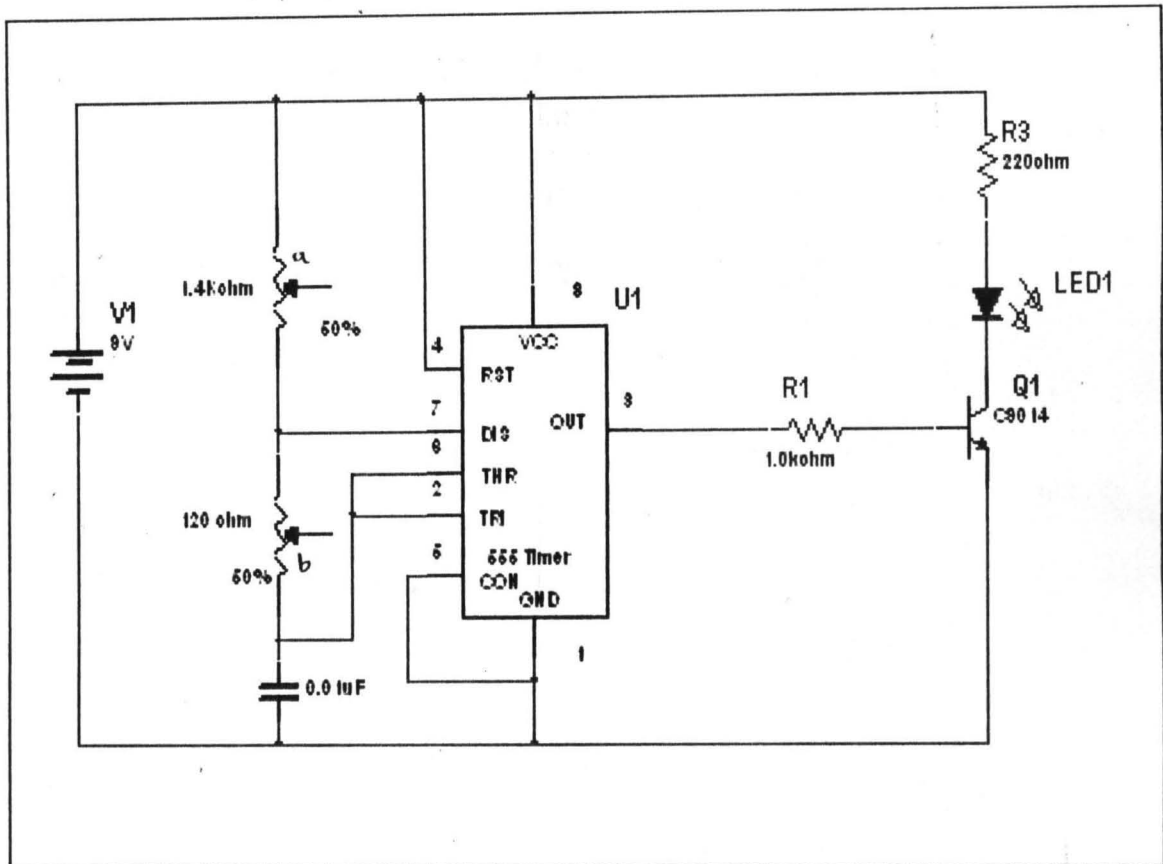

Fig 4: Remote Control Transmitter Circuit

When the button is closed, a 38KHz signal given by

$$F = \frac{1.44}{(R_a + 2R_b)} \text{ KHz}$$

Is generated. This frequency is chosen to match the 38KHz reception frequency range of the TSOP 1738 infra red sensor.

At the instant of pressing the ON and OFF button, a burst of the 38KHz signal is generated.

This received by the sensor and triggers the mono stable to generate a clock pulse that toggles the logic from either ON to OFF, or OFF to ON state.

3.4.2 THE RECIEVER UNIT.

This subsystem is designed around a 555 multi-vibrator chip configured in the mono stable mode as shown fig 5.

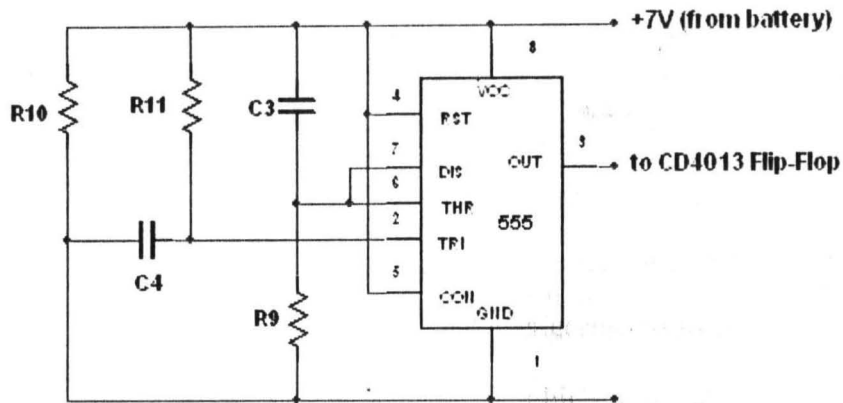

FIG: 5 Receiver unit.

The mono stable generated an output pulse whose width is given by the relation below.

$$T = (1.1RC) \text{ sec.}$$

Where;

R = Resistance between V_{cc} (pin 8) and pins (6,2).

C = Capacitance between pins (6,7) and grounded.

The mono stable is triggered by a falling level signal coupled to its pins (trigger input).

ATSOP 1738 38KHz infra red sensor is connected to pin 2 of the mono stable through a capacitor of $0.1\mu\text{F}$. The sensors output is high in the absence of an Infra Red transmission, but switches low when an Infra Red signal is detected.

This low -going transition pulls pin 2 towards the ground, triggering the mono stable and setting its output (pin 3) high for a true period established by

$$T = 1.1RC.$$

A 1-second output pulse width is needed to be fed into the system control logic unit shown fig6

3.5 THE SYSTEM CONTROL UNIT.

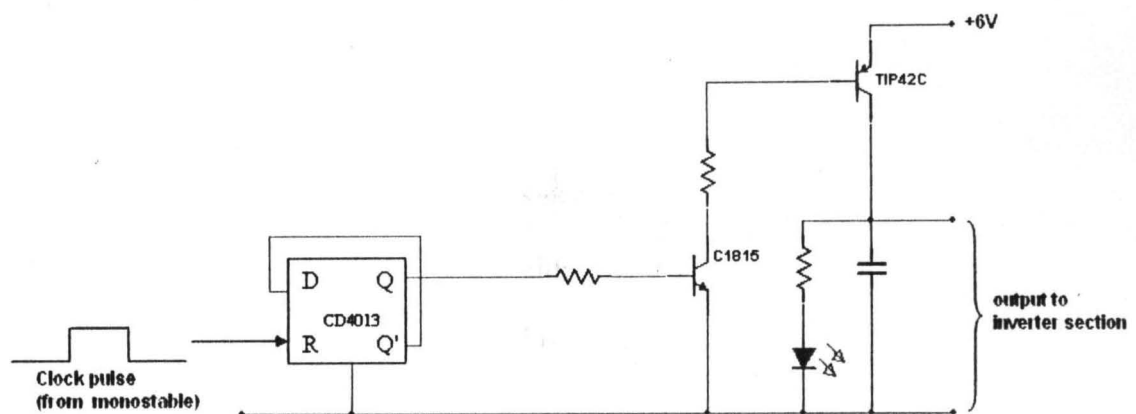

FIG:6 The system control unit (T- FLIP FLOP)

The system control logic unit features a T- flip flop derived from D flip flop by connecting its Q output to its D input.

Successively clock pulse cause the flip flop to change state alternatively, i.e Q switches high with one clock pulse, and low with the next pulse.

The Q output drives a NPN transistor whose collector is corrected to the base of a 4A PNP transistor.

When the Q output of the D – flip flop is high , the C1815 NPN transistor is switched hard on, pulling its collector potential low, turning the PNP switching transistor on.

Battery Voltage is hence fed through the emitter of the transistor to its collector to power the high frequency converter unit.

When the small signal NPN transistor switches off, the PNP transistor is turned off, and the power to the converter section is interrupted.

3.6 HIGH FREQUENCY INVERTER SUBSYSTEM.

These consist of two high frequency of D882 NPN transistor connected in a push – pull arrangement.

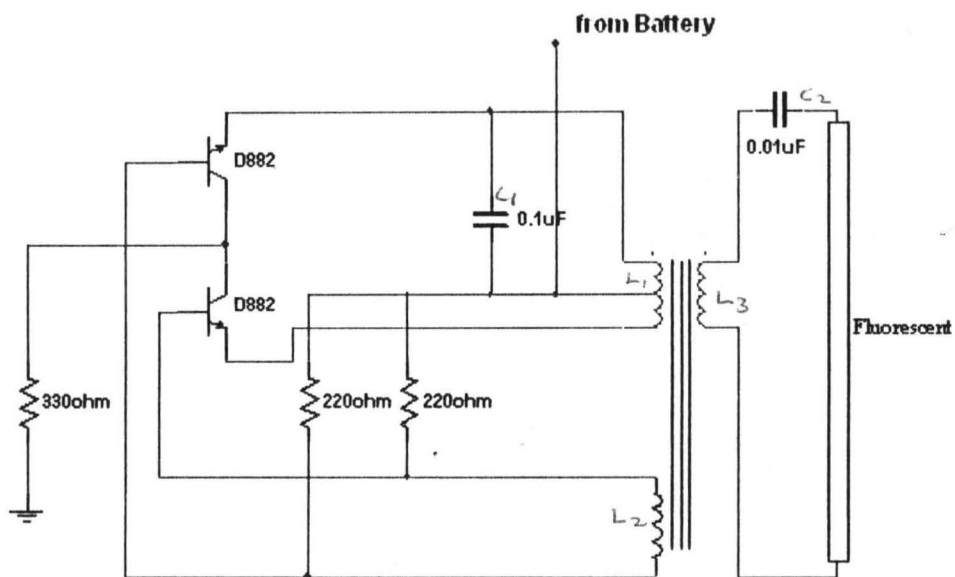

FIG:7 The high frequency inverter circuit.

TI is a ferrite cored transformer.

L1 and C1 form a resonant tank circuit for the two switching transistors. L2 is the feedback coil, and L3 is the output coil connected to the fluorescent tube.

At the instant of applying power to the oscillator section, slight imbalance in the symmetry causes one of the either transistors to turn on earlier than the other, causing an oscillatory current to flow through L1.

An alternated replica of the oscillatory current at a frequency set by the value of C1 and L1 is fed to the bases of the both transistors through 180 degree out of phase. This causes the previously non – conducting transistor to switch ON, and the earlier ON transistor to OFF. This alternate ON and OFF switching action, generate a high frequency sinusoidal output through L3 connected to the load.

The Voltage generated is of a high magnitude, but small current which is high enough to cause a fluorescent bulb to glow.

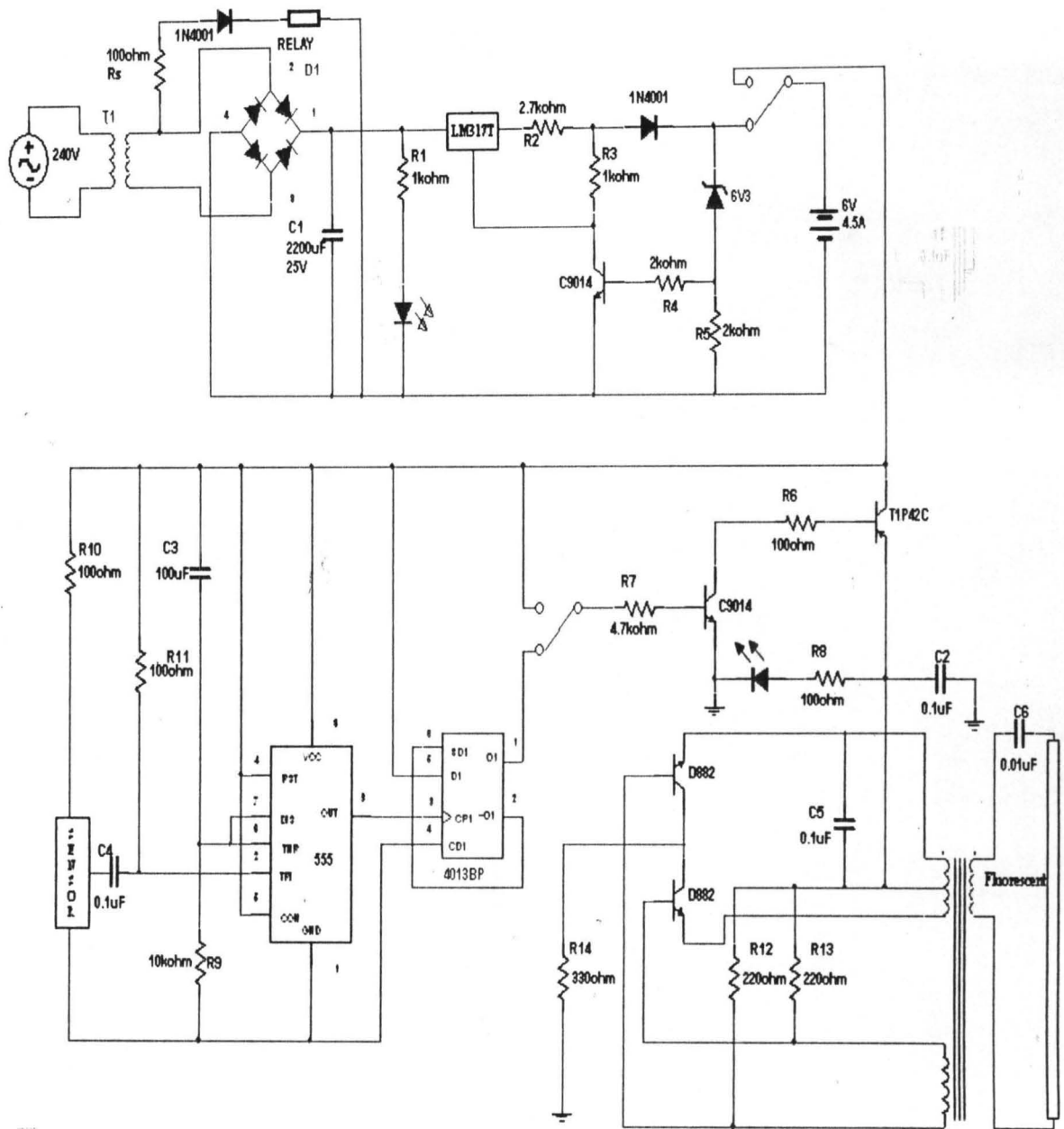

FIG: 8. The general circuit diagram.

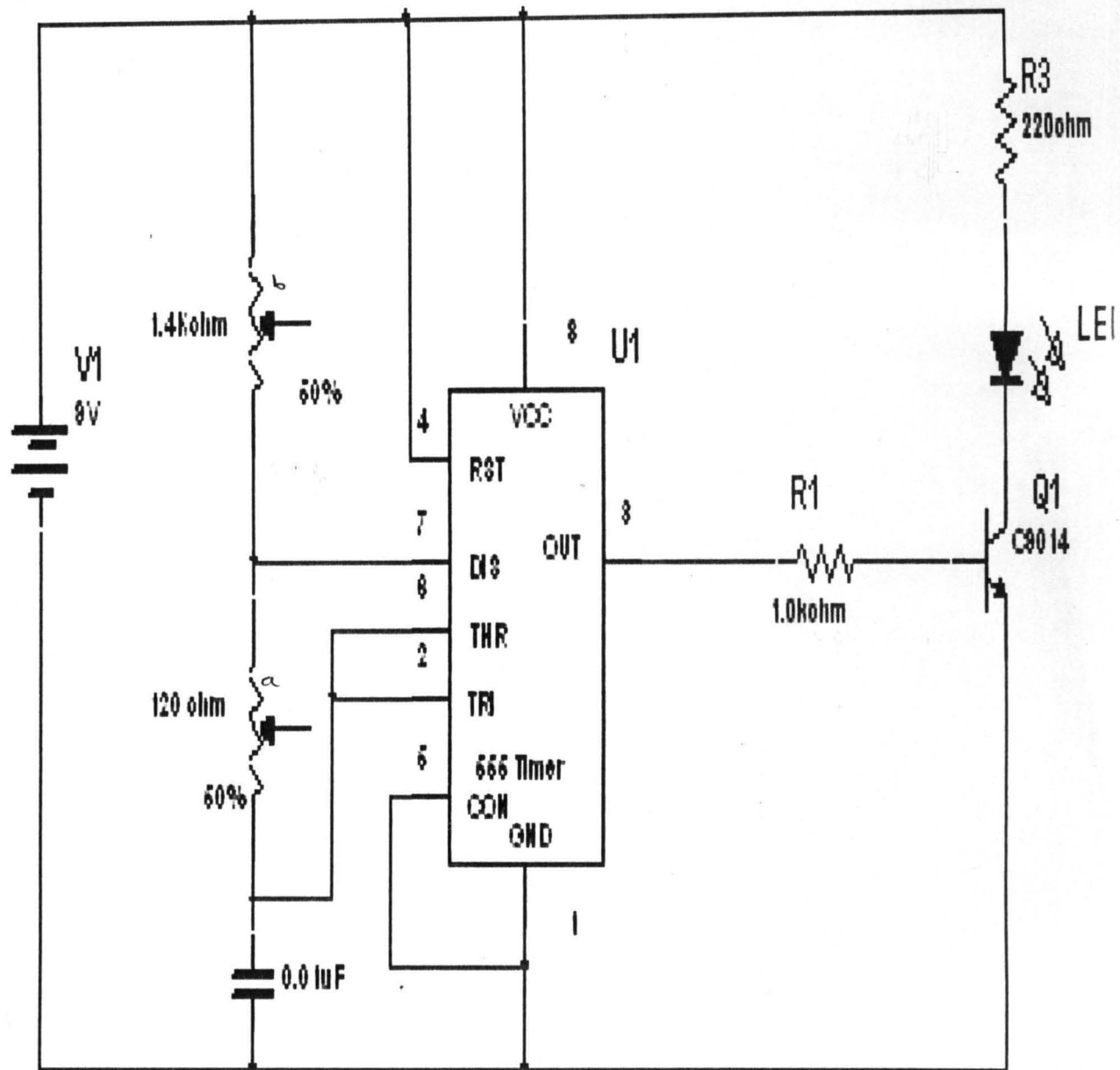

FIG: 9. The remote control.

CHAPTER FOUR

4.0 CONSTRUCTION, TESTING AND RESULTS.

4.1 CONSTRUCTION.

This chapter focuses on the construction procedures and techniques used to construct the device, the testing and the results obtained.

To ease construction procedures, the project circuitry was segmented into functional blocks. A component layout plan was then drawn to ease construction.

The construction includes a prototype on the location of bread board followed by the final construction on the Vero boards.

4.2 COMPONENT LAYOUT.

The layout plans for the electronic components location on the Vero boards were drawn out on sheets of graph paper so as to ensure the following.

- a. Economic of the amount space used on the Vero boards.
- b. The best connection routes for the components.

The functional blocks which the projects circuitry were broken into are as follows:

- Power Supply.
- Battery charging unit.
- Infra red remote control receiver unit.
- Infra red remote control transmitter unit.
- System control unit.

- High frequency resonant inverter unit.

4.3 HARDWARE CONSTRUCTION.

The initial construction and component connections was done on the breadboard. Each block was tested and the results obtained before the components were permanently soldered onto the Vero board.

4.3.1 SOLDERING.

A soldering iron (40W) a plastic suction tube and soldering lead were used during the soldering process.

Precaution taken during soldering includes the following:

- It was ensured that an adequate amount of soldering lead was used.
- IC sockets were used so that they are not destroyed by the intensive heat generated by the soldering iron and lead.
- It was ensured that the soldering of each component was done in a quick and efficient manner, so as to avoid overheating and hence possible destruction.

4.3.2 TESTING AND ANALYSIS.

On completion of the construction, a thorough test and assessment of the components connection was carried out. The following steps were followed.

- a) The continuity and connectivity of the jumper wires and links were taken using a multi-meter while the circuit was not powered.
- b) The construction was tested block by block.

- c) The measurement of capacitance, current, resistance and voltage were taken and compared with design values.

4.3.3 TOOLS USED.

1. **BREADBOARD:** This was used for the initial construction of the project. A breadboard (sometimes called a "proto board") is a board which has been filled with tiny conductive holes which are interconnected in a specific pattern. They are used for building prototype circuits, since they are an excellent way of joining things together without using solder. The electronic components are plugged right into the breadboard to connect them, and when done, they are pulled back out.
2. **VERO BOARD:** this was used for the final construction on the electronic components were soldered. It has parallel strips of copper track on one side. The tracks are 0.1" (2.54mm) apart and there are holes every 0.1" (2.54mm).
3. **SOLDERING IRON:** A 40W soldering iron with some soldering lead was used to solder the components to the board. A suction tube was also used to clean up excess or misplaced lead from the board's surface in order to avoid short circuits and obtain a neat solder job.
4. **MULTIMETER:** The most fundamental part of electronics is being able to see what amounts of voltage, current, or resistance are in a particular component. This is almost always the first thing you do in analyzing any electronic device. Thus, a good multi-meter is one of the electronics engineers most fundamental tools.
5. **MULTISIM:** this electronic simulation software was used to model and simulate the circuit.

4.3.4 PACKAGING.

The complete constructed circuit on the vero-board was then housed in a plastic casing.

CHAPTER FIVE

5.0 CONCLUSION AND RECOMEMDATION.

5.1 CONCLUSION.

Conclusively, it was obvious that there was a realistic solution to power outages in Nigeria. The cost of an inverter system that has the same power output with some generator was far lower than the cost of the generator which implies it was a device that commons could afford.

The art and technology was not too complex, and above all, it was in existence. In addition, more knowledge and understanding of transformer winding, transistor as a switch and amplifier was acquired.

The inverter device was also very cheap to maintain compare to the generating sets that needs to be fuelled to maintain constant operation. The inverter does not produce any noise like other generating system of its capacity which produces unbearable noise when in use.

The remote control system has facilitated the operation of light switch around the home or an office.

5.2 RECOMMENDATION.

Since the field of electronics remains ever dynamic, it was always very possible to modify the designs for better performance. In view of this, I recommended that any student who wished to embark on this type of projects should use:

- Power mosfet for switching large currents.

- The device was recommended for use as an alternative low power supply in home and offices, for lightning.
- An IC can be incorporated into the circuit such as SN7401C, 7404IC to oscillate the incoming DC signal, for transistor to amplified and then switch into output transformer of the required power ratings.

REFERENCES

- [1] Paul Horowitz , Winfield hill, The Art of Electronics, 2nd Ed,
Cambridge University Press, London,1995, Pg 62
- [2] Len jones, Basic electronics for tomorrows world, 1st Ed,
Cambridge University Press, London, 1993pg 345
- [3] paul M. George: Power Inverter, 1st Ed, University press, California, pg 123.
- [4] Adeolye Eniola, Construction of 500AV Inverter, Electrical Engr., FUT Minna, 2000.
- [5] Abachi Eugene, Construction of power inverter, Electrical Engr., FUT Minna, 2004.
- [6] Forrest M. Mims III (1986) An Electronic principle, John wiley and sons New York
pg 45
- [7] Engineers mini- note book on opto-electronic circuit, 1st Ed, Siliconconcept.
- [8] Jerome Olesky (1976) Practical solid state design, 1st Ed, Howord W. sans & Co. pg45
- [9] Robin Mu (1995) : Power Electronics converter, application and design,
John Wiley & sons New York, pg 2.
- [10] George C. Chrysis, High frequency switch power supplies theory, and design, MC
Graw Hill New York, 1994, pg 114-118.
- [11] Paul H. (1995): The Art of Electronics, Cambridge University
press pg 48
- [12] Victor H. Grinich and Horace G. Jackson: Introduction to Integrated
Circuits Publisher: Macmillan publishers Ltd.

- [13] S. W. Amos, principle of transistor circuit, 6th Ed, Hartnolls Ltd. 1981 pg56
- [14] B L Theraja and A K Theraja (1994); A text book of Electrical Technology
21st Ed, publication division of Nirja Construction and Development
Co(p) Ltd, Ram Ngar.
- [15] Charles Wenzel, the IR Remote technology at <http://www.epanorama.net.ups> pg234

APPENDIX

OPERATIOAL MANUAL

- Connect the cord of the charger unit to a maximum of 240V socket and turn ON the charger for charging processes.
- Connect the cord of the fluorescent lamp to the output of the charger unit.
- Press the button on the remote control to turn ON the rechargeable fluorescent lamp if there is power failure or when the charger unit is turned OFF
- Press the button on the remote control to turn OFF the rechargeable fluorescent lamp if required.