

# **Design and Construction of a public Address (P.A) System With Automatic Back-up Power Supply**

**BY**

**ISTIFANUS AUDU BAHAGO  
99/8113 EE**

**FEDERAL UNIVERSITY OF TECHNOLOGY,  
MINNA.  
DEPARTMENT OF ELECTRICAL/COMPUTER  
ENGINEERING**

**NOVEMBER, 2005.**

**Design And Construction of a Public Address (P.A) System  
With Automatic Back-up Power Supply.**

**BY**

**ISTIFANUS AUDU BAHAGO**

**99/8113 EE**

**DEPARTMENT OF ELECTRICAL/COMPUTER ENGINEERING,  
SCHOOL OF ENGINEERING AND ENGINEERING TECHNOLOGY,  
FEDERAL UNIVERSITY OF TECHNOLOGY,**

**MINNA.**

**NIGER - STATE.**

**A Project Report submitted to the Department of Electrical/Computer  
Engineering as a partial fulfillment of the requirement for the award of  
Bachelor of Engineering in Electrical/Computer Engineering.**

## DECLARATION

I declare that the project and the report are entirely my efforts, and to the best of my knowledge, has never been either wholly or partially submitted somewhere else before.

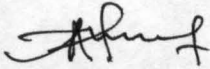

.....

**ISTIFANUS AUDU BAHAGO**

6TH DECEMBER, 2005

**Date**

# CERTIFICATION

I certify that this project "DESIGN AND CONSTRUCTION OF PUBLIC ADDRESS (P.A.) SYSTEM WITH AUTOMATIC BACK-UP POWER SUPPLY" was carried out by Istifanus Audu Bahago, under the supervision of Mr. U.A Usman in the Department of Electrical/Computer Engineering, School of Engineering and Engineering Technology, Federal University of Technology, Minna, Niger State, Nigeria.

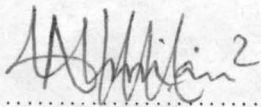

.....  
Mr. U.A Usman  
Project Supervisor

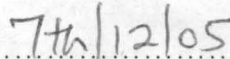

.....  
Date

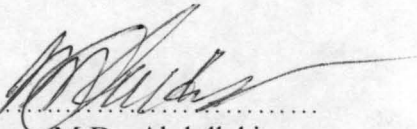

.....  
Engr. M.D. Abdullahi  
Head of Department  
Electrical/Computer Dept.

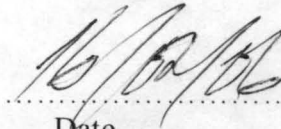

.....  
Date

.....  
External Examiner

.....  
Date

## ACKNOWLEDGEMENT

First and foremost my utmost thanks goes to God Almighty, the Absolute and Arbitrator, with whom any and all things are possible and who has made this journey possible thus far. In His Name were all things made and without Him was not anything made. In Him is life; and the life is the light of men. Thank you for all mercies both great and small.

To my parents Mr. and Mrs. Audu Bahago go many and plenty of thanks for all the support in various ways – financial, moral, spiritual, mental and otherwise. May God, the Lord of host continue to; bless you. Amen

To my siblings – Zamani, Naomi, Ibrahim, Maria, Rahila, Nuhu, Afiniki, Maryamu and Lois, do I share this occasion with. You have been an ocean of support to me.

I appreciate also all my colleagues and friends particularly; Harry Wayo (Parostica), Mlaku (Kluvert), Latifat Olaniyi (Ola 2000), Sarah and Aisha, Becky Garba (Bosso Girl), Austyn Egoche (Gosh man), and specially Aleru Suleiman (Yaro), John Akah (John Patriot) and Danjuma Kufana (Dekuf). Thanks for all the sacrifice and support. May the light of God Almighty continue to shine down on you all?

To my dedicated supervisor Mr. U.A Usman, who has been of immense help throughout the duration of this project, I say a very big thank you sir.

Worthy of mention is Mr. Umar Suleiman whose kindness and understanding is second to none. Here's wishing you the very best in your endeavors.

And to my Head of Department, Engr. M.D Abdullahi and the staff of the Department of Electrical/Computer Engineering, I express my sincere gratitude for the training from 1999 to date.

Last but not the least, my deepest appreciation go to the Chief of Army Staff (COAS) and the Defense authority without whose approval I would not have been opportune to study in this great university.

Thank God for His grace, enablement and His divine intervention for counting me among the living in order to acquire this basic skill needed. To God be the glory

## DEDICATION

This project is dedicated fully to the Almighty God, may His grace and mercies upon us never end.

And to my beloved parents Mr. and Mrs. Audu Bahago, you are unique individuals.

## ABSTRACT

A Public Address (P.A) System into which an automatic back-up power supply unit is incorporated is designed and built. The preamplifier stage has a total voltage gain of 1033.9. The input and output power of the P.A system are 27.23W and 20.25W respectively. Also the P.A system has an efficiency of 74.37 %. The incorporated back –up power supply is a 12v dc supply from batteries (cells) which is linked up to a charging circuit with 15.94v out put voltage having a charging current of 2.50 A. The achieved back-up power supply unit makes the PA system reliable in the event of power failure from the mains.



## LIST OF FIGURES

- 1.0 Block diagram illustrating process of signal in P.A system
- 2.1 Transformer- couple push- pull amplifier
- 2.2 Transformer less push-pull amplifier
- 2.3 Quasi-complimentary push-pull amplifier
- 2.4 Basic differential amplifier circuit
- 2.5 Symbol for op-amp
- 2.5a Inverting gain connection
- 2.5b Non-inverting gain amplifier
- 2.6 Classification of amplifier by mode of operation
- 3.1 Block diagram of amplifier
- 3.2 Voltage gain of pre-amplifier stage
  - 3.2.1 Power amplifier diagram
- 3.3a Bridge rectifier circuit
- 3.3b AC input wave form
- 3.3c Output wave form of rectified positive half circle of ac
- 3.3d Output waveform of rectified negative half circle of ac
- 3.3e Output waveform of full wave rectification
- 3.4 Dual power supply circuit
- 3.5 12v Battery charger
- 3.6 Presentation of view of casing

## TABLE OF CONTENT

	PAGE
TITLE PAGE .....	i
DECLARATION .....	iii
CERTIFICATION .....	iv
ACKNOWLEDGEMENT .....	v
DEDICATION .....	vii
ABSTRACT .....	viii
LIST OF FIGURES .....	ix
TABLE OF CONTENT .....	x
<b>CHAPTER ONE: GENERAL INTRODUCTION</b>	
1.1 INTRODUCTION .....	1
1.2 OBJECTIVES AND SCOPE OF STUDY .....	2
1.3.1 MICROPHONE .....	4
1.3.2 AMPLIFIER .....	5
1.3.3 LOUDSPEAKERS .....	5
<b>CHAPTER TWO: LITERATURE REVIEW</b>	
2.1 HISTORY OF SOUND RECORDING AND REPRODUCTION .....	7
2.2 PREVIOUS PROJECT WORK ON P.A SYSTEM .....	8
2.3 DESIRED IMPROVEMENT .....	9
2.4 AMPLIFIERS (DETAILED STUDY) .....	9
2.4.1 PUSH – PULL AMPLIFIER .....	12
2.4.2a TRANSFORMER – COUPLED PUSH – PULL AMPLIFIER .....	12
2.4.2b TRANSFORMERLESS PUSH – PULL AMPLIFIER .....	14

2.4.2c QUASI – COMPLIMENTARY PUSH – PULL AMPLIFIER .....	15
2.5 AUDIO AMPLIFIER .....	16
2.6 DIFFERENTIAL AMPLIFIER .....	16
2.7 OPERATIONAL AMPLIFIER .....	18
2.7.1 PARAMETERS OF OPERATION AMPLIFIERS .....	19
2.8 INVERTING AND NON-INVERTING AMPLIFIERS .....	20
2.8.1 VOLTAGE GAIN OF OP-AMP .....	20
2.8.1a INVERTING AMPLIFIER .....	20
2.8.1b NON-INVERTING AMPLIFIER .....	21
2.9 POWER AMPLIFIER .....	22
2.10 FURTHER CLASSIFICATION BY OPERATING MODE	22

### **CHAPTER THREE: DESIGN AND CONSTRUCTION**

3.1.0 DESIGN PROCEDURE .....	25
3.1.1 PRE-AMPLIFIER STAGE .....	26
3.1.2 POWER AMPLIFIER STAGE .....	28
3.1.3 POWER SUPPLY UNIT .....	31
3.1.4 VOLTAGE REGULATION .....	35
3.2 CHARGING CIRCUIT .....	36
3.3 CONSTRUCTION AND PACKAGING CONSTRUCTION .....	37

### **CHAPTER FOUR: EVALUATION**

4.1 TEST WITH POWER SUPPLY FROM THE MAINS .....	39
4.2 TEST WITH POWER SUPPLY USING BATTERY .....	39
4.3 TEST FOR AUTOMATIC POWER SWITCH-OVER AC-BATTERY	39
4.4 CONCLUSION .....	40

4.5	LIMITATION .....	41
4.6	RECOMMENDATION .....	41
4.7	APPENDIX A .....	42
4.8	APPENDIX B .....	43
4.9	REFERENCES .....	46
	COMPLETE CIRCUIT DIAGRAM .....	47

# CHAPTER ONE

## GENERAL INTRODUCTION

### 1.1 INTRODUCTION

Sound reproduction equipment is used to amplify voices and instruments so they can be heard at a great distance from the source. Systems designed for this purpose are referred to as Public Address (PA) Systems. The term may also refer to system designed solely to amplify speech. Such a system may range from simple microphone and loudspeakers and amplifiers.

The importance of Public Address systems in our society cannot be over emphasized to peculiarity. For a highly populated country like Nigeria, a pastor for instance in a Church, cannot conveniently address congregation of over five hundred people using his natural voice else, only probably half of the congregation hears him. Or an imam calling prayers in the mosque aimed at reaching faithful who may be several meters away from the mosque.

Addressing a large gathering in either official or social function requires to a great deal the use of public address systems. The difficulty of a teacher, raising his voice to be heard by the student is overcome by the use of a Public Address system. A teacher after using a public address system had this to say "I don't have to strain my voice anymore, I just speak in normal tone and it grabs their attention. And I don't have to repeat myself as much".

Though the society have gone for centuries without public address systems, experts say the world is much noisier now. Ventilation systems, lawn movers, street traffic, social functions, religious activities and overcrowded schools are just some of the things that have contributed to the noisier environment; People are blowing their voices out. They didn't do that years ago. But now, they have to talk over all this noise.

The benefit of a P.A system is actually for all and sundry. Evidence shows for instance that, in a classroom where teachers use P.A systems, students get better scores, and show

improved behavior and self esteem. "Its long overdue." Says a clinical audiologist. " I know that classroom P.A system will do very good for children's listening and learning what classroom lighting did for children's seeing." With the P.A system, a teacher gives direction, and don't have to walk up there and ask again, and the students don't have to scoot up in their chairs to try to hear him. The P.A system encourages participation and gives confidence. It is relatively cheap in its design and is very simple, although large out door systems for music concerts involve clusters of loudspeakers. These clusters are spread through out a venue, such as in a sports stadium, large auditorium e.t.c each clusters hold many loudspeakers, which sound at high loudness levels. For extremely large venues, this cluster can be

Synchronized with the activities on stage, so that action and sound will match.

## 1.2 OBJECTIVE AND SCOPE OF STUDY

The objective behind this study is to design and construct a P.A system. The work goes further to increase the effectiveness of the P.A system by the inclusion of an automatic back-up power supply in case of power failure from the mains supply

The project shall implore the use of a microphone as input into the amplifier which amplifies the signal into a desired sound level to be heard at the output via a loud speaker. The block diagram in fig 1.0 below illustrate the process of a signal in a public address system.

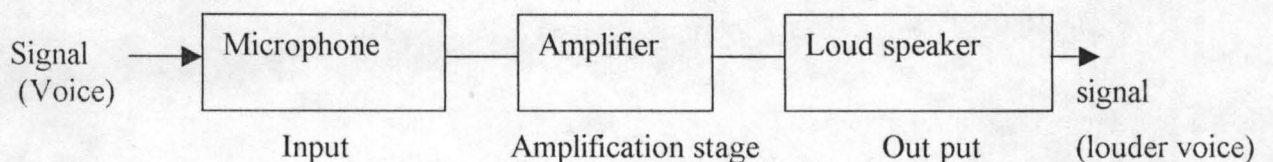

Fig 1.0 Block diagram of signal process in a P.A system.

As shown in the block diagram, the process of P.A system begins with an input in the form of voice signal into a microphone. This voice signal is actually a sound energy which is

then transform into electrical energy by the microphone. The microphone in turn serves as input to the amplifier. Here the sound energy which is in the form of electrical energy is received and amplified to desired level. What the device does actually is increase the amplitude or power, of the electric signal. It should be noted here that, the amplified signal is usually a weak electric current drawn from either the electrical signal representing sound and or for many other purposes. The amplified signal is then channel through an output device called the loudspeaker which enables a loud sound to be heard at the output. Here amplified electric signal is converted into a loud sound signal.

Since the process of rising the strength of a weak signal for better performance is known as amplification and the device that brings about the amplification process is called an AMPLIFIER, the process of amplification is very important in all areas of communication systems. For example, the radio wave signal picked up by the receiving antenna possesses extremely small power of the order of milliwatt and in some cases microwatt. However, such power must be amplified to several other of watts to be able to produce adequate loud speaker response in the radio receiver.

Similarly, the output sound of a microphone is a fraction of a watt and must be amplified hundreds of times to make it possible to fill a large auditorium with sound. As a matter of great importance, amplifiers find wide applications in both commercial and industrial fields e.g. in intercommunications system, television etc.

This unique characteristic of the amplifier is employed in the public address (P.A) system. The P.A system, is a device which consist of several stages of amplifiers connected in cascade arrangement (i.e. output of the first is connected to the input of the second) to make a whole bulk of amplifier called the multistage amplifier.

With the recent increase in demand in the usage of a P.A system to address large crowd in crusades, lecture theaters, churches etc, the need also becomes an obligatory task

to incorporate an automatic back-up power supply for continuous usage of the device in case of electric power failure which has become erratic in recent times.

The components used in the process discussed above are described below.

### **1.3.1 MICROPHONE**

This is a device used to transform sound energy into electrical energy. Microphone is important in many kinds of communications system and in instruments that measure sound and noise. The simplest type of modern microphone is the carbon microphone, used in telephones. These microphones consist of a metallic cup filled with carbon granules, a moveable metallic diaphragm mounted in contact with the granules. Covers the open end of the cup. Wires attached to the cup and diaphragms are connected to an electric circuit so that a current flows through the carbon granules. Sound wave vibrates the diaphragm, varying the pressure in the carbon granules. The electrical resistance of the carbon granules changes with the varying pressure causing the current in the circuit to change according to the vibrations of the diaphragm. The varying current may be amplified and transmitted to a distance receiver. If the current variation is suitably amplified, it may also be used to modulate a radio transmitter.

Another common type, the crystal microphone utilizes piezo electric crystals, in which a voltage develops between two faces when pressure is applied to the crystals. In this mic. Sound waves vibrate a diaphragm, which in turn varies the voltage, which is then amplified.

Examples of dynamic microphones include ribbon microphones and moving coil microphones. In ribbon microphone, a thin metallic ribbon is attached to the diaphragm and placed in the magnetic field. When sound waves strike the diaphragm and vibrate the ribbon; a small voltage is generated in the ribbon by electromagnetic induction. A moving



coil microphone operates on essentially the same principles but has a coil of light wire, instead of a ribbon, attached to the diaphragm. Some modern microphones, designed to pick up sound from one direction only combine both ribbon and coil elements.

Among the important characteristics of microphones are their frequency response, directionality, sensitivity and immunity to outside disturbances such as shock or vibrations.

### 1.3.2 **AMPLIFIER**

This is a device for increasing the amplitude, or power of an electric signal. It is used to amplify the weak electric current drawn from the antenna of a radio receiving set, the weak output of a photo electric (electric eye), the electrical signal representing sound in a public address system, and for many other purposes. One commonly used amplification device is the transistor. Other forms of amplifying devices are various types of thermionic vacuum tubes such as the triode, pentode, klystron, and magnetron.

Further study of amplifiers is given in the next chapter since it forms the basis of signal amplifications which is the essence of a P.A system. Hence a P.A system is often referred to as an Amplifier.

### 1.3.3 **LOUDSPEAKERS**

As so often happens, technological breakthrough in one area had a wide ranging impact in others. Development of the high- vacuum tube amplifier did more than make possible the first transcontinental telephone line. It revolutionized communications, leading to creation of new industries including radio, television and sound motion pictures. In a sense, Arnold's breakthrough marketed the beginning of a new electronic age. Among the most immediate results of Arnolds breakthrough was the development of P.A systems. The high-vacuum tube made possible development of the "loud-speaker telephone" (or loudspeaker), allowing many people to hear what conventional telephone receivers had limited to an

audience of one. Further developments in the loud-speakers made possible its use in large crowds, at stadium or in convention halls.

## CHAPTER TWO

### LITERATURE REVIEW

#### 2.1. HISTORY OF SOUND RECORDING AND REPRODUCTION

Sound recording and reproduction began in the late 19<sup>th</sup> century, as several key inventions brought us the technology to change energy from one state to another. In 1876, American inventor Alexander Graham Bell patented the telephone, which incorporates many of the principles used in recording today. This single device required sound to be transferred into different types of energy (by a microphone-type element), required energy to be transported to another location, and then required a loudspeaker like device to transfer that energy back into sound.

The next year American inventor Thomas Alva Edison patented the phonograph, creating recording technology. His cylindrical phonograph, reorded sounds by converting vibrations of air into a groove engraved on a foil-covered rotating cylinder. Future models used special wax as a recording surface. German born American inventor valdemor poulsen patented the first device to record sound magnetically.

The refinement of the vacuum tube in the early 1900s made possible the conversion of sound into electrical impulse and the amplification of these signals. Other important events and development occurred in the 1940s. In 1940 Walt Disney studios released the animated movie fantasia. This film used a new sound process called fanta sound, in which three speakers were placed across the front of the stage and two at the rear corners of the auditorium. The film won a special Academy Award for its creative use of sound. The 1960s brought, another surge of development, beginning with FM stereo broadcast in 1960. The development of three and four track

tape recorders and one inch recording tape began in the early 1960. These developments discussed above chronicles into the public Address system we have today.

## **2.2 PREVIOUS PROJECT WORKS ON P.A SYSTEM.**

Ayara Williams Adewale (2001) attempted in his HND 11 project in Federal Polytechnic, Bida to produce the system under discussion in his work titled “design and construction of a P.A system” Although he uses both transistors and integrated circuits in the design of the amplifier, the work lacked in-depth research. His confining discussion on basically the amplifier makes the work looked like other components were non existing. More so, information was not given about the concept’s origin as a backedground for the project and his hasty conclusion was not the project and his hasty conclusion makes the work half baked.

Kunle Elijah (2003) in his final year project in Federal University of Technology, Minna did a good job in his project titled “Design and construction of a public Address system (200W) stereo’. His aim and objectives was to produced a prototype P.A system which will integrate the following,

- Disco mixer
- Amplifier
- Speakers
- Tape player and recorder

More so, his aim at achieving the following is also commendable;

1. Reduced the cost of acquisition of a good P.A system i.e a P.A system that is free of noise, low and clear.
2. Reduced the size of the P.A system.

3. Eliminate too many interconnection of system hence elementary unwanted interference and wire complexity.
4. Produced a high frequency sound system that can be easily marketable.
5. Produce a local P.A system that stands a chance of replacing imported ones.
6. Allows for low cost of maintenance of combination of systems put together.

His consideration on the unfortunate cost of assembling this appliance to achieve a good P.A system in our society and which is due to the unfavorable economic situation, especially high cost of imported goods, did not look at the inconvenience being caused by erratic power supply from PHCN. This situation is capable of putting to mess the whole process of putting into usage the system.

Hence this project proffers solution to the highlighted problem.

### **2.3 DESIRED IMPROVEMENT**

This project shall construct a P.A system which incorporates the microphone, amplifier and loud speakers. Its application shall be such that both the audience and the P.A system are located in the same room or hall. The audience or at least much of it can hear the person speaking but probably with a degree of difficulty. What is wanted is reinforcement.

But most importantly, the project shall increase the effectiveness of a P.A system by the inclusion of an automatic back-up power supply in case of power failure from the mains supply.

### **2.4 AMPLIFIERS (DETAILED STUDY)**

In general, practical amplifiers always consist of a number of stages that amplify a weak signal until sufficient power is available to operate a loud speaker or any other out put device. The first few stages in a practical amplifier is the function of only voltage

amplification, while the last is solely designed to provide maximum power. This last or final stage is called the power stage of the amplifier.

Amplifiers of either the transistor or tube variety may be classified in several ways. One of such ways is by means of the coupling circuit, such as RC-coupled (resistance-capacitance coupled) amplifier. Some other categories include classification by purpose (i.e. what the amplifier does) and also classification based on the mode of operation such as class A.

A great deal of information about an amplifier can be revealed by merely stating inter stages coupling method used. The RC-coupled amplifier is so named because of a coupling capacitor from the load resistor (resistance) of one stage to the input of the next stage. A transformer coupled amplifier is so named because a transformer is use to couple two or more stages. The direct-coupled amplifier usually called a dc amplifier allows both the amplification of dc and ac signal. It has special circuit that reveals the absence of capacitors and transformers as coupling devices different stages of amplification.

A very important feature of some amplification is their ability to amplify only the signals lying with a given band of frequencies and to reject those outside the given band. Such amplifier is called TUNED AMPLIFIERS. They are solely designed to amplify signals in a frequency band that is centered on a chosen carrier frequency, and not amplify signals which lie outside this band. Tuned amplifiers thus form an important part of radio and television receiver is the radio frequency (r.f) and intermediate frequency (i.f) amplifier section.

As earlier stated, amplifier also may be classified by the use for which they are designed. Therefore, audio frequency ( a.f ) amplifier are intended to operate over the general range of about 20 Hz – 20KHz. While radio frequency amplifiers are solely use to amplify

signals in the range of about 100 Hz. They are usually used as the first stage of amplification in selective radio receivers.

The intermediate frequency amplifiers are used mainly in radio, radar and television receivers. The large majority of broadcast radio receivers employs IF amplifiers which operates at a frequency of 445 KHz. In frequency modulated receivers, an IF of 10.7MHz is used, and television receivers uses 26-46 MHz IF frequencies. (6).

In most applications, one stage of amplification can not provide gain, so two or more stages are connected together ( i.e cascaded ) to provide the required gain, where a pre-amplifier is made to precede a power amplifier in an audio amplifier.

The gain of an amplifier, is so defined as the ratio of the output voltage or current to the input voltage or current respectively for a sinusoidal input voltage or current. Under the usual method used in analyzing a.c circuits, the gain is seeing as a complex number indicating both the magnitude of the gain and the phase angle by which the output voltage lags the input voltage in time. An amplifier can not perfectly reproduce the waveform or frequency spectrum of the input signal. The ability of the amplifier to faithfully, reproduce a signal is measured by either its frequency response or its time response. There are some undesirable conditions that may occur in amplifiers; these may produced by improper circuit design and also by inherent limitations in the physical operation of the devices used.

In general, good circuit designs can considerably reduce all the undesirable conditions, including those created by physical limitations, to a level where they are not noticeable. If it is noticed that the output signal from an amplifier is not an exact reproduction of the input signal, then distortion has set in. so far, amplifies have been designed in which distortion is extremely very small. Noise encountered in amplifies may be classified as THERMAL NOISE and SHOT NOISE. Thermal noise result from the random motion of electrons inside the resistors, conductors, tubes and transistors, while shot noise is the name

given to the noise generated in transistors and vacuum tubes by the random emission of holes or electrons from the emitter or cathode.

Degeneration in amplifier is the loss of gain through an unintentional negative feedback. It can be reduce to a negligible value by the inclusion of a bypass capacitor with sufficiently small reactance at the signal frequency. On the other hand, regeneration increases the gain of the amplifier through an unintentional positive feedback. In the worst form of the regeneration, the amplifier becomes an oscillator.

#### 2.4.1 **PUSH-PULL AMPLIFIER**

The name of the amplifier is indicative of the circuit operation. One transistor is conducting while other one is off, and vice versa. The push- pull amplifier can be achieved as a transformer-coupled and transformer less push-pull amplifier. The push-pull amplifier is a power amplifier that is frequently employed In the output stages of electronic circuits. It comes into use whenever high output power at high efficiency is required.

##### 2.4.2a **TRANSFORMER- COUPLED PUSH-PULL AMPLIFIER.**

Fig 2.1 shows the circuit of a transformer- coupled push-pull amplifier. The circuit uses a centre-tapped input transformer (i.e driver transformer) to produce opposite polarity signals to the two transistor inputs and also an output transformer connected to the load (loud speaker) to operate in a push-pull mode.



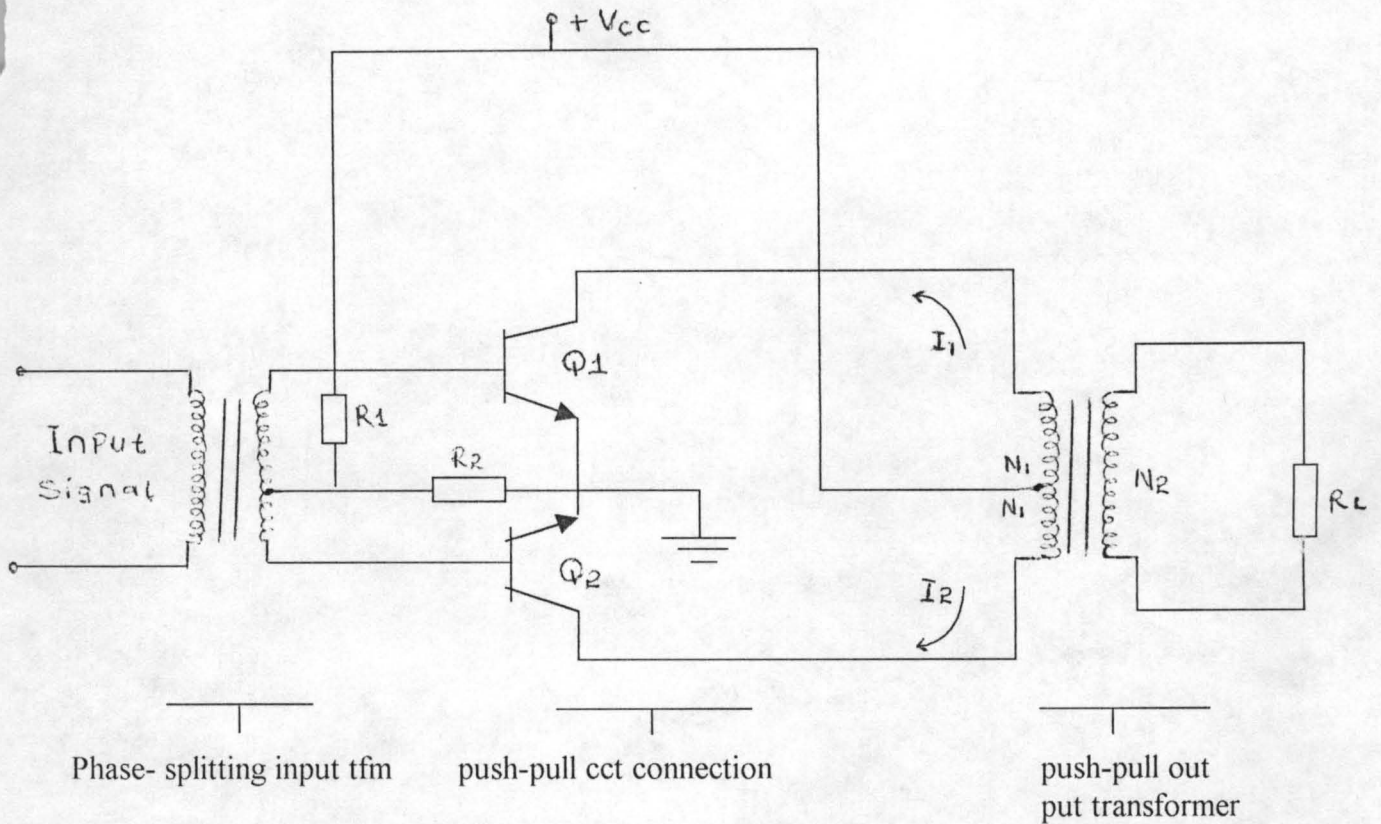

Fig 2.1: Transformer- coupled push-pull amplifier.

The input signal appears across the secondary coil XY of the driver transformer. During the first half – cycle of operation when end X becomes positive and end Y negative, transistor Q1 is driven into condition, whereas transistor Q2 is driven off. The current  $I_1$  flows through the transformer in the first half- cycle of the signal to the load. At the second half-cycle of the signal to the load. Thus, the overall signal developed across the load then varies over the full cycle of signal operation. The input signals are  $180^\circ$  out of phase.

It should be noted here that the push-pull circuit arrangement permits a maximum power transfer to the load by means of impedance matching. If the resistance appearing across the secondary coil of the transformer is  $R_L$ , the resistance  $R_L^1$ , of the primary coil becomes

$$R_L^1 = \left( \frac{N_1}{N_2} \right)^2 R_L$$

Where

$N_1$  = Number of turns between either end of primary Winding and the centre- tap

$N_2$  = Number of secondary turns.

## 2.4.1B TRANSFORMERLESS PUSH-PULL AMPLIFIER

There are many methods for eliminating the need for the transformers at both the input and output. One of such methods encompasses the Push – pull amplifier, that utilizes the same type of transistors for the output stages, i.e either both NPN or both PNP.

The input to the output stage still require signals that are  $180^\circ$  out of phase, just as in the transformer – coupled amplifier. These signals are furnished by a driver circuit as shown in fig 2.2.

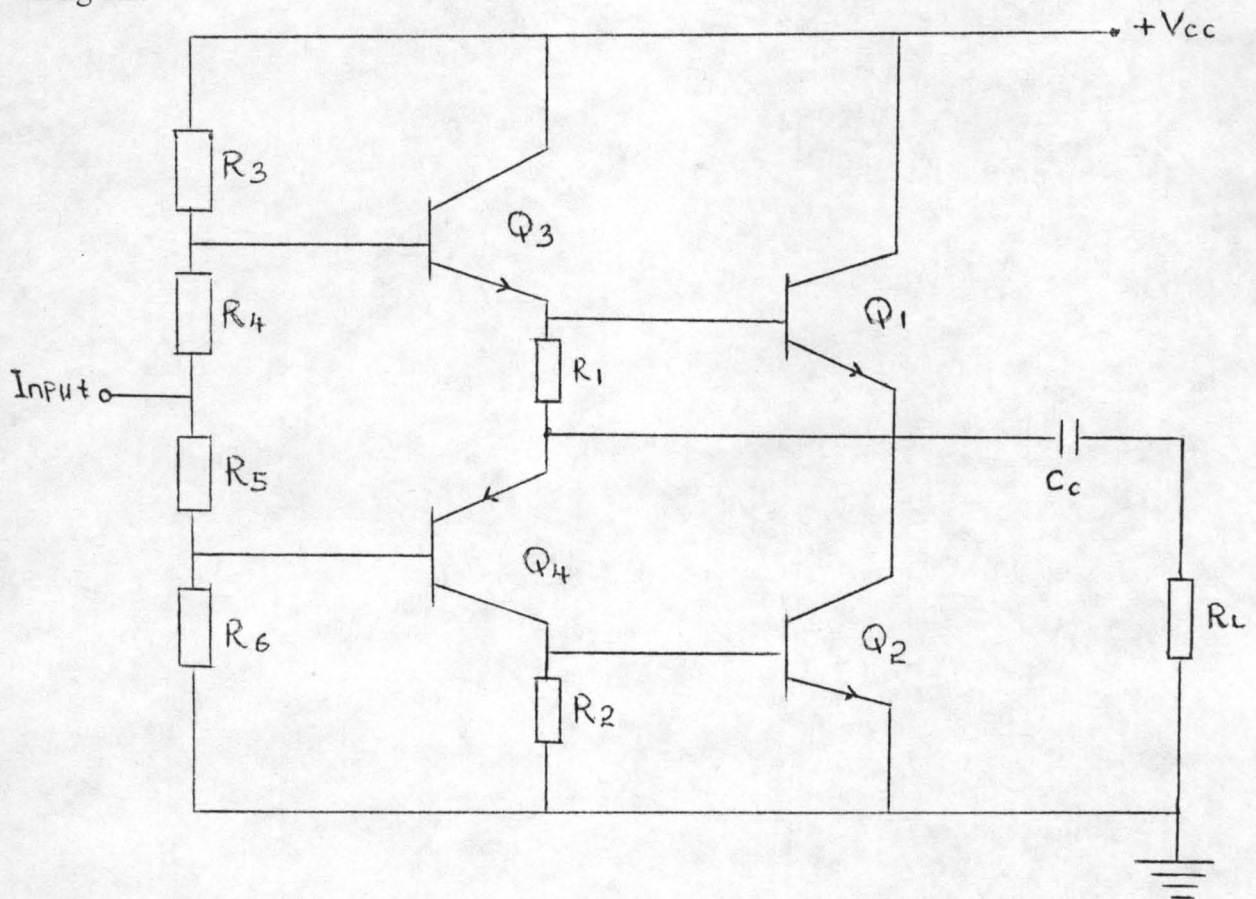

Fig. 2.2 Transformerless Push-Pull Amplifier

Driver transistor Q3 and Q4 are of complementary types, one an NPN and the other PNP, thus providing outputs that are out of phase but having common input. The transformer less push-pull amplifier shown in fig., 2.2, uses single power supply to operate other design like the complementary – symmetry push-pull amplifier uses dual power but of opposite polarity. Here, the output signal, is capacitively couple to the load.

## 2.4.2c

**QUASI – COMPLEMENTARY PUSH-PULL AMPLIFIER**

In practical power amplifier circuits it is preferred to use NPN transistor for both high – current output devices. A practical way of achieving complementary operation while using the same type of matched NPN transistors for the output stage is with the help of a quasi – complimentary circuit shown in fig 2.3

In order to achieve the push – pull operation, transistors Q1 and Q2 are made complementary (NPN and PNP) before the matched NPN output transistors seen to be Q3 and Q4.

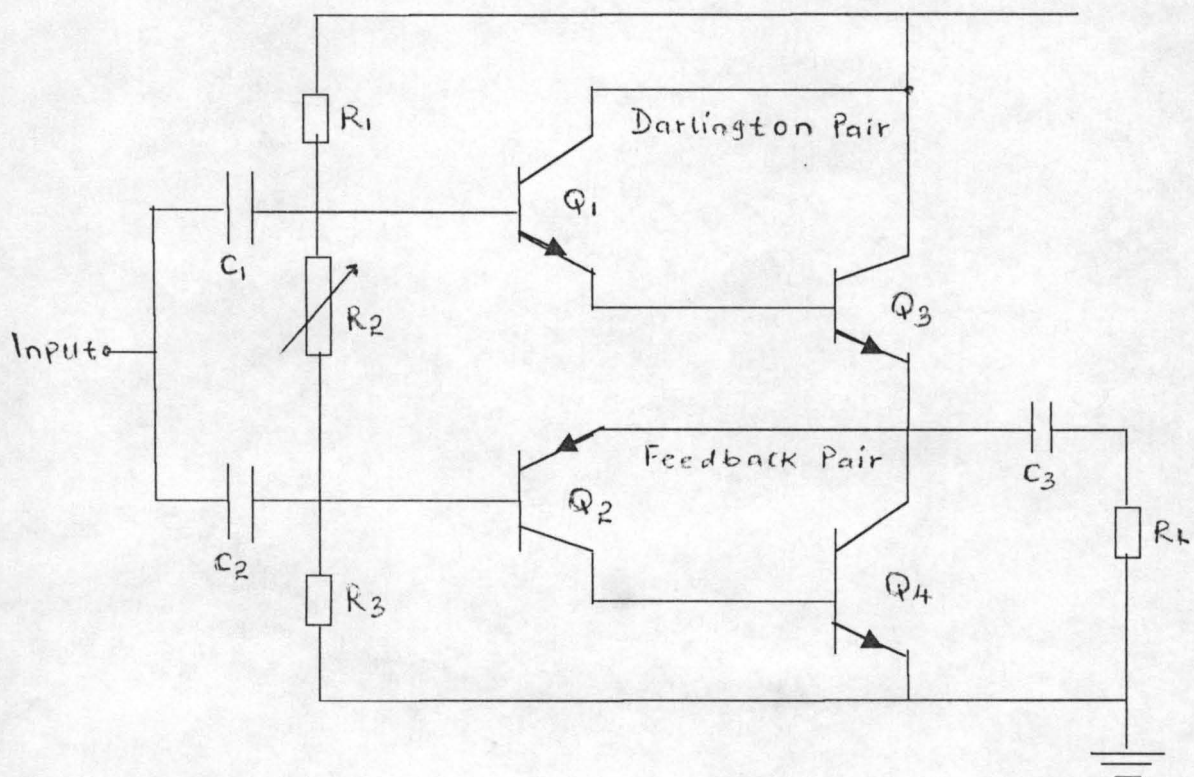

Fig 2.3 Quasi – complimentary push – pull amplifier

In this setup, transistor Q1 and Q3 form a Darlington pair connection which provides output from a low-impedance emitter follower. Similarly, the connection of transistor Q2 and Q4 results in a feedback pair which also provides a low-impedance drive to the load. Resistor R2 is properly adjusted to reduce the problem of crossover distortion. Cross distortion refers

to the problem encountered during the signal crossover from positive to negative half-cycle or vice versa, resulting in some nonlinearity in the output signal.

The single input that is applied to the push-pull stage then results into a full cycle output to the load

## **2.5 AUDIO AMPLIFIER**

An audio amplifier is an electronic circuit meant for the amplification of signals within and in some cases above the audible range (i.e. 20 Hz – 20KHz). The term may mean either the complete amplifier consisting of voltage amplifier and power amplifier stages or on the other hand may mean just a single stage.

The function of an audio amplifier is to amplify a weak electrical signal, such as from a phone pick – up or a microphone to a level capable of driving a loudspeaker at a desired sound level. Audio amplifiers may be constructed with Vacuum tubes; however, current technology favors the use of transistors and integrated circuits, ICs.

## **2.6 DIFFERENTIAL AMPLIFIER**

A differential amplifier is an extremely popular circuit in IC units. It can be best described by considering the basic circuit of a differential amplifier shown in fig 2.4. It has two separate inputs, with two separate outputs while its emitters are connected together.

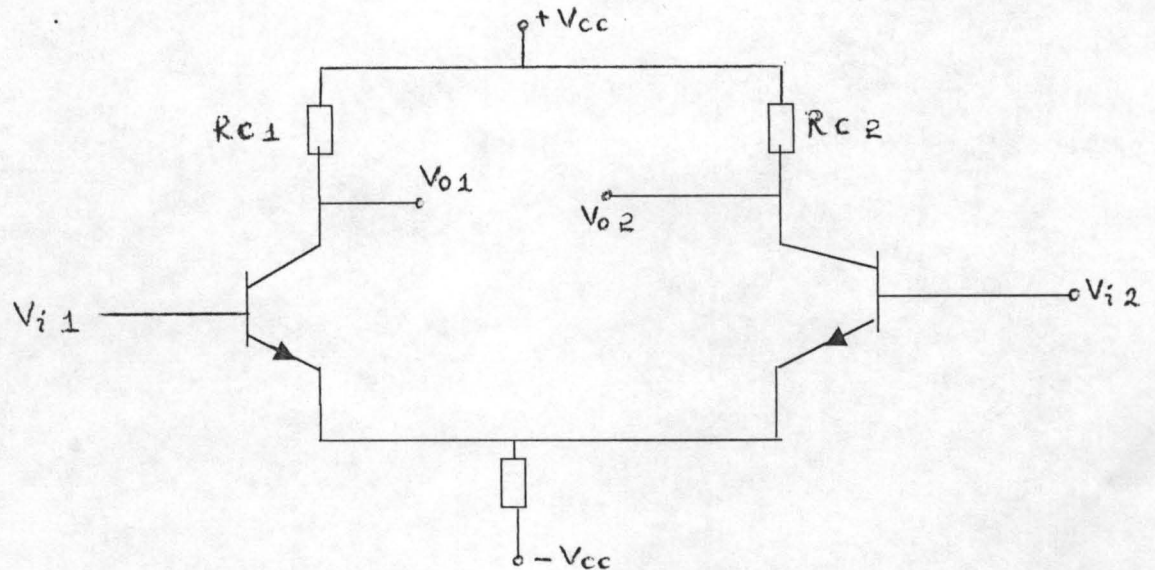

Fig 2.4 Basic differential amplifier circuit.

A number of input signal combinations are possible using the differential amplifier.

With an input signal applied to either of the input, when the other is connected to the ground, the operation then is referred to as DOUBLE-ENDED.

However if the same input signal is applied to both inputs, the operation is referred to as COMMON – MODE. Most differential amplifiers uses two separate voltage supplies, but the circuit can still operate using a single supply.

In single – ended operation, output results from both collectors. This is because of the common – emitter connection that allows the input signal to operate both transistors. For the double- ended operation, the differences of the two input signal result in the output from both collectors. In the common- mode operation, an opposite output signal of each collector results from the common input signal at each of the terminals. The main feature associated with differential amplifies is their very large gain when opposite signals are fed to the inputs

compared with very small gain that is achieved when common signals are fed to the inputs. The ratio of this difference gain to the common gain is called COMMON - MODE REJECTION.

## 2.7 OPERATIONAL AMPLIFIER

An operational amplifier also called an op- amp is a voltage amplifier that amplifies the differential voltage between a pair of input nodes (i.e. inverting and non inverting nodes). It is a monolithic integrated circuit amplifier which has a very high voltage gain, high input impedance and ( for most types ) a low output impedance. The symbol for the op- amp is as shown below in fig 2.5

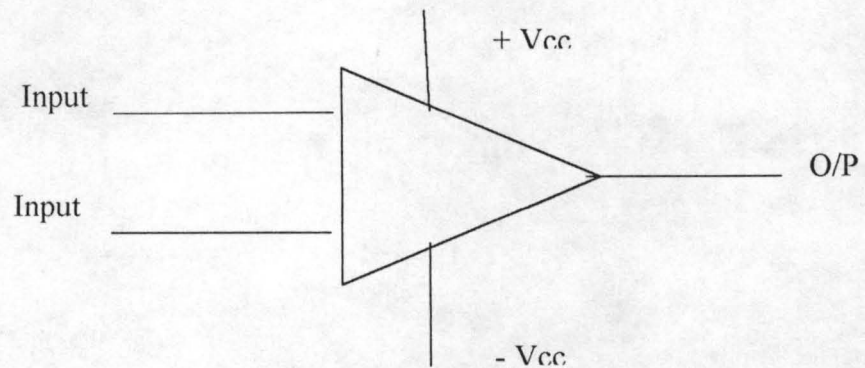

Fig 2.5 symbol for op-amp.

For an op- amp, two input terminal are provide. one labeled - is known as the inverting terminal since a voltage applied to it appears at the out put (o/p) terminal with an opposite polarity to out put voltage ,i.e. a sinusoidal input signal will experience a phase shift of 180°. The other input terminal labeled + is the non inverting terminal; a signal applied at this terminal is amplified with zero phase shifts.

It is worthy of note, to reveal that an op-amp operate with a dual power supply. Two polarities are necessary so that the output voltage can vary either side of zero volt some op-amp can also operate from a single positive supply voltage. An example is the LM 10 (Green, 1981).

Most op-amp are supplied in either 8-pin or 14-pin dual – in –line (DIP) package. In most cases, especially for the second package (14 pin), not all the pins are connected. The majority of op-amps show improved characteristics but the 741 find its wide usage because it is cheap, readily available and its characteristics are quite suitable for many application.

Most op-amps, with 741 inclusive employed bipolar transistors throughout their internal circuitry. Op-amps having junction FET (JFET) input stage are termed BIFET devices while those that uses PMOSFETS in their input stage are known as BIMOS. Also available among op-amps are the CMOS op-amps

### 2.7.1 PARAMETERS OF OPERATIONAL AMPLIFIERS

For an ideal op – amp, following parameters exist:

- i. Infinite input impedance
- ii. Zero output impedance
- iii. Infinite voltage gain
- iv. Infinite bandwidth
- v. Zero output voltage when equal voltages are applied to the two input terminals.

But in practical terms, an ideal op-amp does not exist, since practical devices have their various limitations.

**INPUT RESISTANCE:-** Input resistance of an op-amp largely depend upon the type of transistors used in its input stage. Typically, the input resistance of a bipolar op-amp may be in the range of 100 k ohm to 10 m ohm and as large as  $10^{12}$  ohm for BIFET or BIMos type

**OUTPUT RESISTENCE:** Because op-amp is essentially voltage amplifier, its output resistance is made low as possible and typically, is within the range of 50 ohm to 4k ohm

**VOLTAGE GAIN:** commercially available op-amps have open loop gains which vary from one type to another. This voltage gain, is within the range of 10,000 to 200, 000 (3).

## 2.8 INVERTING AND NON – INVERTING AMPLIFIER

When an op –amp is used as an amplifier, a large amount of negative feedback is applied in order to specify accurately the voltage gain of the amplifier. There are basically two such possible ways an op-amp can be connected to serve as an amplifier; one is the inverting gain connection. The diagram for both type of connection is shown in fig 2.5a and 2.5b.

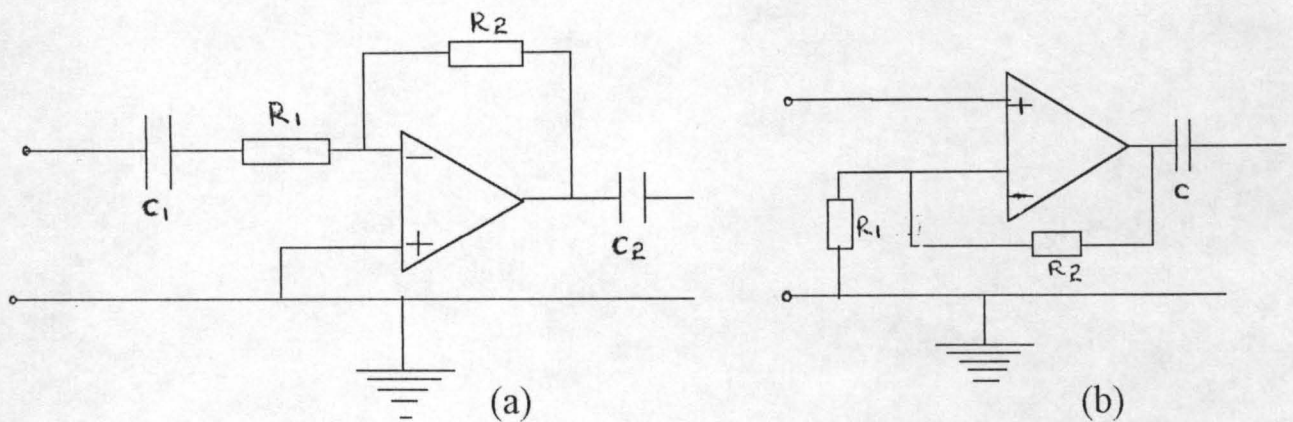

Fig. 2.5; (a) Inverting gain connection (b) Non-Inverting gain connection.

### 2.8.1 VOLTAGE GAIN OF AN OP-AMP

#### 2.8.1a INVERTING AMPLIFIER:

From fig. 2.5 (a), the input voltage  $V_i$  appears across  $R_1$  which gives the input current as  $V_i/R_1$ . Since the input impedance of the op-amp is high, it means very little current will therefore flow through the resistor  $R_2$  and the voltage that is developed across  $R_2$  is the same with the out-put voltage  $V_o$  of the circuit.



Therefore,

$$V_1/R_1 = -V_o/R_2$$

$$\frac{V_o}{V_1} = -\frac{R_2}{R_1} \text{ but } AV = V_o = \text{voltage gain}$$

$$A_v(f) = -\frac{R_2}{R_1}$$

### 2.8.1b NON – INVERTING AMPLIFIER

For the non- inverting amplifier, as showing in fig. 2.5(b) the output voltage  $V_o$  of the circuit is given by  $A_v (V_1 - V_x)$ .  $A_v$  is the open- loop gain of the op-amp while  $V_x$  is the voltage that appears at the inverting terminal,

$$\text{But } V_x = \frac{V_o R_1}{R_2 + R_1}$$

Therefore

$$V_o = A_v \left[ V_1 - \frac{V_o R_1}{R_2 + R_1} \right]$$

$$A_v V_1 = V_o \left[ 1 + \frac{A_v R_1}{R_2 + R_1} \right]$$

And

$$A_v(f) = \frac{V_o}{V_1} = \frac{A_v}{1 + \frac{A_v R_1}{R_2 + R_1}}$$

The inherent voltage gain  $A_v$  of the op- amp is very and so

$$\frac{A_v R_1}{R_2 + R_1} \gg 1,$$

Therefore

$$A_v(f) = \frac{A_v}{A_v R_1 / (R_1 + R_2)}$$

Or

$$\begin{aligned} A_v(f) &= \frac{R_1 + R_2}{R_1} \\ &= 1 + \frac{R_2}{R_1} \end{aligned}$$

## 2.9 POWER AMPLIFIER

This is the output stage or final stage in a multistage amplifier such as in audio amplifier and radio transmitter, designed to deliver appreciable power to the load. Primarily, power amplifiers provide sufficient power to an output load to drive a speaker or other devices, typically ranging from few watts in an audio amplifier to many thousand of watts in a radio transmitter.

## 2.10 FURTHER CLASSIFICATION BY OPERATING MODE

The operating modes of transistors are prescribed by the designation of classes A, B and C respectively, with certain divisions among these classes. The distinction between the various classes is determined for a sinusoidal signal voltage applied to the input terminals. The Q-point and the extent to the characteristic being used determine the method of operation. Whether the transistor is made to operate either as class A, B or C amplifier is determined from the following short definition.

**CLASS A-** In this type of amplifier operation, the operating point and the input signal are such that the current in the output circuit (in the collector) flows at all times. It thus implies that a class A amplifier operates essentially over a linear portion of its characteristic.

**CLASS B -** This type of amplifier operation, has its operating point at an extreme end of its characteristic, so that the Q- power is very small, therefore, either the input voltage

signal is sinusoidal, amplification takes place for only one – half cycle. For instance, if the Q-output circuit current is zero, this current will remain zero for one- half cycle.

CLASS AB – In this class of operation, the amplifier operates between the two extremes defined for class A and B. hence the output signal is zero fore part but less than one-half of the input sinusoidal signal cycle.

CLASS C – In this amplifier, the operating point is chosen so that the output current or voltage is zero for more than one - half of the input sinusoidal signal cycle.

Below is the varying wave form of the different classes see fig 2.6.

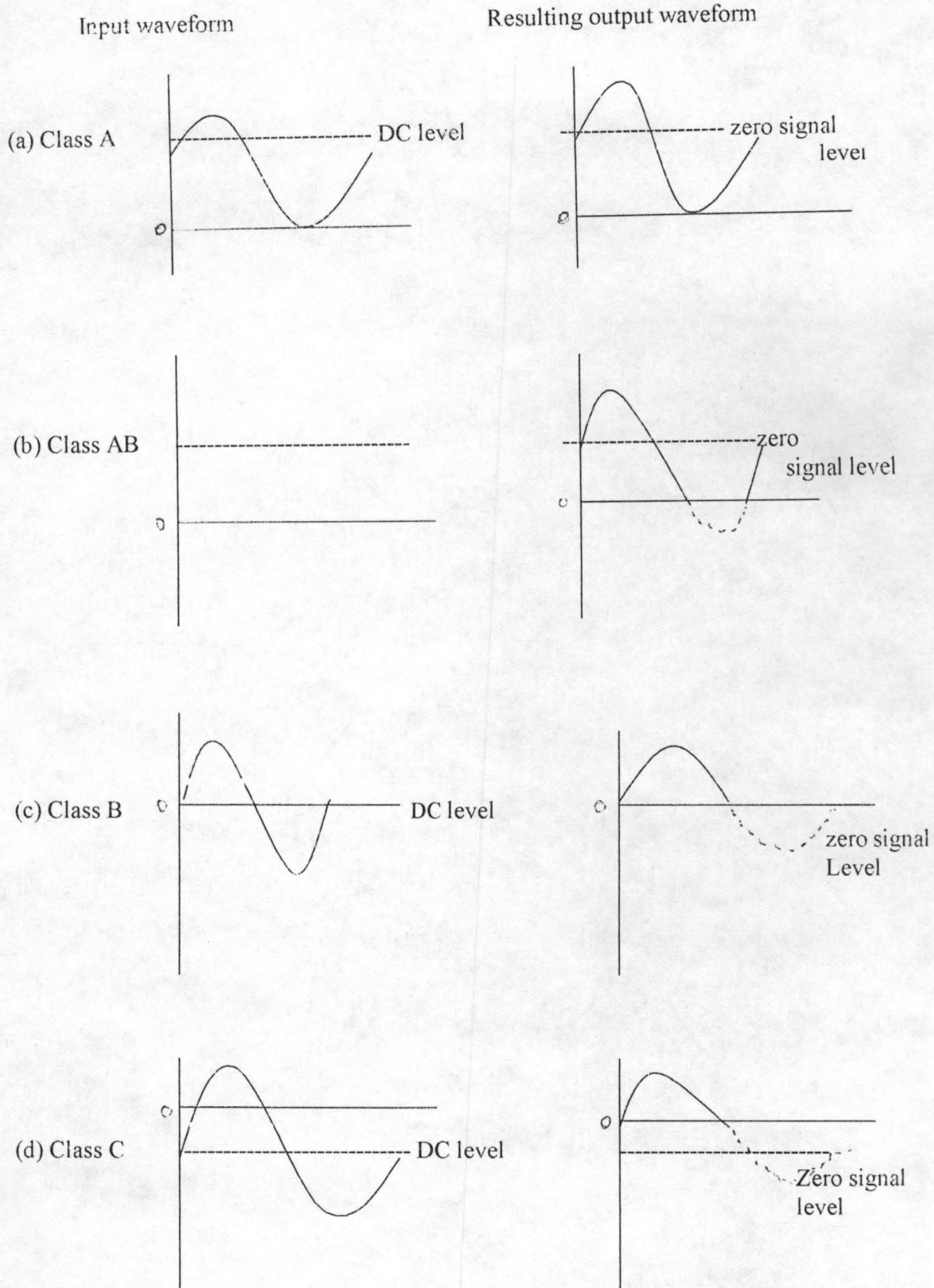

Fig. 2.6 Classification of Amplifier by mode of operation.

## CHAPTER THREE

### 3.0 DESIGN AND CONSTRUCTION

#### 3.1.0 DESIGN PROCEDURE

Designing an amplifier involves the choices of circuit configuration. The circuit configuration defines the type of circuit being used; whether all transistor circuit or the use of transistor and integrated circuit (IC). This choice is necessary, so that the amplifier can operate satisfactorily under specified conditions.

The amplifier designed for this purpose uses both transistor and integrated circuits, not forgetting that other components like capacitors, resistors were also used. Shown in fig. 3.1, is the stages that makes up the amplifier.

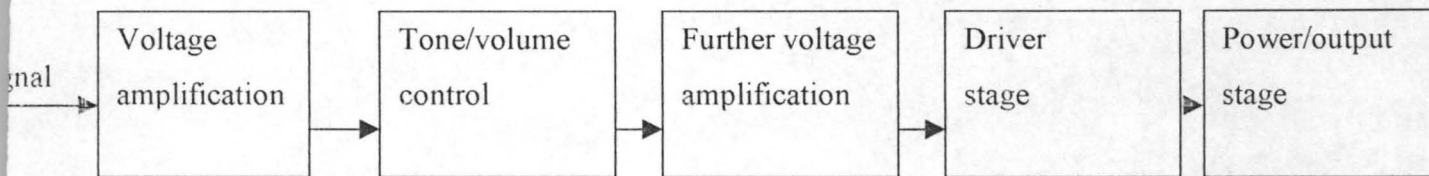

Fig. 3.1 Block diagram of amplifier

Stage 1 and 3 are operational amplifier whose aim is to amplify the voltage of the signal stage 2 comprises mainly resistors and capacitors while stages 4 and 5 comprise mainly transistors and resistors.

In the study of amplifiers that led to its design, parameters like power efficiency, output power, maximum power dissipation were considered. Based on the earlier discussion (chapter two) of amplifier classification a class B push-pull amplifier was used and this push-pull amplifier has efficiency of 78.5% (7).

### 3.1.1 PREAMPLIFIER STAGE

The preamplifier used are op-amps. They both include the UA 741 and JRC 4557D. They are general purpose devices, having a Vcc nominal voltage of 15v and also requires dual power supply.

The UA 741 serves as the preamplifier at the input stage while JRC 4558D, is meant for further preamplification after which the signal amplified by the UA741 must have passed through the tone and volume control circuit. The voltage gain of the preamplifier is as shown below:-

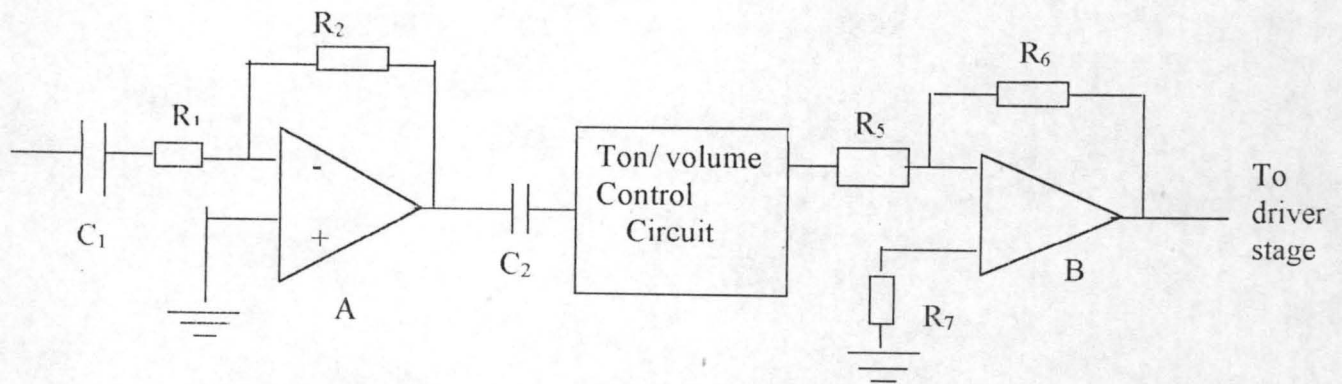

Fig. 3.2 Voltage gain of preamplifier stage.

$R_1 = 10k, R_2 = 33k, R_5 = 150, R_6 = 47k, R_7 = 47k$

A = UA741                  B = JRC 4558D

For inverting gain:

$$\text{Voltage gain } AV_1 = \frac{V_{\text{out}}}{V_{\text{in}}} = \frac{R_2}{R_1} \dots\dots\dots \text{Eqn 3.1}$$

$$= \frac{33 \times 10^3}{10 \times 10^3}$$

$$= 3.3$$

Further voltage gain  $AV_2 = \frac{V_{out}}{V_{in}}$

$$= \frac{-R_6}{R_5}$$

$$= \frac{47 \times 10^3}{150}$$

$$= 313.3$$

$$\begin{aligned} \text{Total voltage gain } A_v &= A_{v1} \times A_{v2} \\ &= 3.3 \times 313.3 \\ &= 1033.9 \end{aligned}$$

### 3.1.2 POWER AMPLIFIER STAGE

The power amplifier stage consist of a class B amplifier in the complimentary push-pull arrangement. Each transistor supplies current to the load  $R_L$  for half an a.c. cycle. In so doing, each of the transistor is out of phase with the other  $180^\circ$  (8). Driver stage consist of transistors TiP41 and 42.

The output power of the amplifier, is as calculated below.

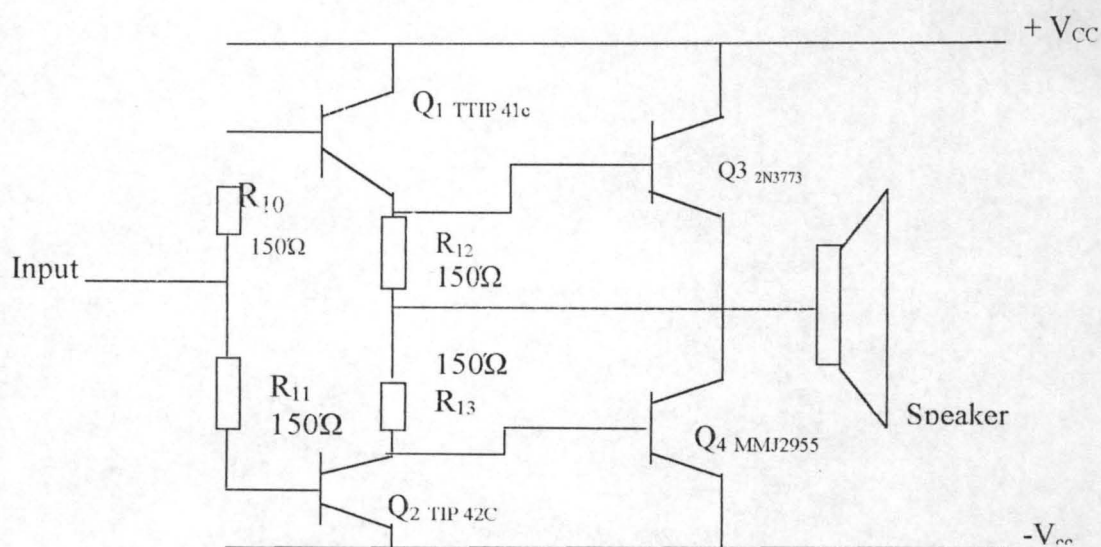

Fig. 3.2.1 POWER AMP DIAGRAM

Input Power (dc) from supply

$$P_i \text{ (dc)} = V_{cc} I_{dc} \dots \dots \dots \text{Eqn 3.3.}$$

$I_{dc}$  is average dc current

$$I_{dc} = \frac{2}{\pi} I_L \dots \dots \dots \text{Eqn 3.4}$$

$I_L$  is the dc current flowing through load  $R_L$

$$I_L = \frac{V_L}{R_L} \dots \dots \dots \text{Eqn 3.5}$$



$V_L$  is the peak voltage across load  $R_L$ .

From oscilloscope,  $V_L = 18V$ , while output load being fed is  $8 \Omega$

From equation 3.5

$$I_L = \frac{18}{8} \\ = 2.25 \text{ A}$$

$I_{dc}$  from equation 3.4

$$I_{dc} = \frac{2}{\pi} \times 2.25 \\ = 1.43 \text{ A}$$

From Equation 3.3

Input power  $P_i$  is

$$P_i (\text{dc}) = 19.04 \times 1.43 \\ = 27.23 \text{ W}$$

OUTPUT POWER (ac)

$$P_o (\text{a.c.}) = \frac{V_L^2}{2R_L} \dots \dots \dots \text{Eqn 3.6}$$

$$= \frac{18^2}{2 \times 8} \\ = \frac{324}{16} = 20.25 \text{ W}$$

### EFFICIENCY OF THE AMPLIFIER (POWER EFFICIENCY)

**Percentage efficiency** =  $\frac{\text{ac output power}}{\text{dc input power}} \times 100\%$

$$= \frac{P_o (\text{ac})}{P_i (\text{dc})} \times 100\% \dots \dots \dots \text{Eqn. 3.7}$$

From Eqn 3.7

$$\text{Percentage efficiency} = \frac{20.25}{27.23} \times 100\%$$

$$= 74.37\%$$

Power dissipated by output transistors.

The power that is dissipated as heat by the output transistors is the difference between the input power delivered by the power supply and the output power delivered to the load.

$$P_{2Q} = P_i (\text{dc}) - P_o (\text{ac}) \dots \dots \dots \text{Eqn 3.8}$$

$P_{2Q}$  is the total power dissipated by the two output power transistor. Power that is dissipated by one transistor is given by

$$PQ = \frac{P_{2Q}}{2} \dots \dots \dots \text{Eqn 3.9}$$

From equation 3.8

$$P_{2Q} = 27.23 - 20.25$$

$$= 6.98\text{W}$$

From equation 3.9

$$PQ = \frac{6.98}{2} = 3.49\text{W}$$

### 3.1.3 POWER SUPPLY UNIT

The design of the amplifier required a dual power supply. The power supply in this design uses a bridge rectifier to convert the alternating current (ac) at the secondary terminal of the transformer to direct current (dc). The transformer steps down the 240v ac to 30v (i.e.  $2 \times 15\text{v}$ , since the transformer is center tapped).

The bridge rectifier was employed because it supplies large amount of dc power. The rectifier comprises of four diodes D1, D2, D3 and D4. During the positive half cycle of the ac supply, diodes D1 and D2 conducts, thus Developing output voltage across the load resistance  $R_L$ . At this time diodes D3 and D4 are reversed biased or non-conducting. On the negative half cycle, diodes D3 and D4 conducts while D1 and D2 are reversed biased thus resulting in a full-wave rectified output dc voltage.

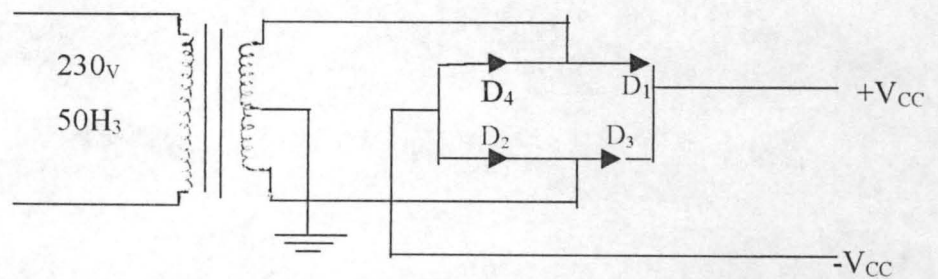

(a)

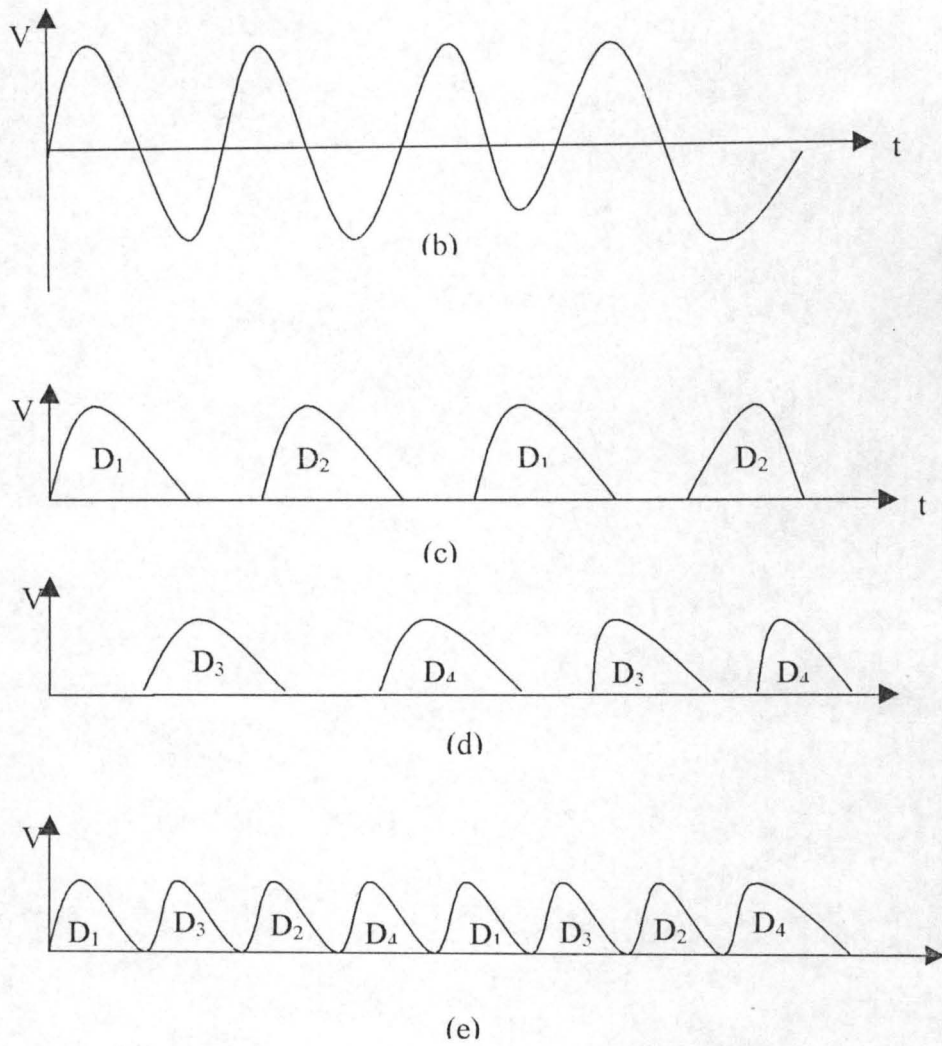

Fig. 3.3 (a) Bridge rectifier circuit

(b) Ac input wave form

(c) Output waveform of rectified positive half cycle of ac

(d) Output wave form of rectified negative half cycle of ac

(e) Output waveform of full wave rectification.

To obtain the dual supply, two capacitors of equal capacitance ( $4700\ \mu\text{F}$  is used in this project) are arranged in series such that the centre-tapped terminal of the transformer is placed at the junction between the two capacitor to form zero potential i.e.  $0\text{V}$ , while either ends formed by the series arrangement produces the required voltages of opposite polarities. These capacitors also helps in smoothening the dc voltage from the rectifier. The circuit for the dual power supply is as shown below in fig. 3.4.

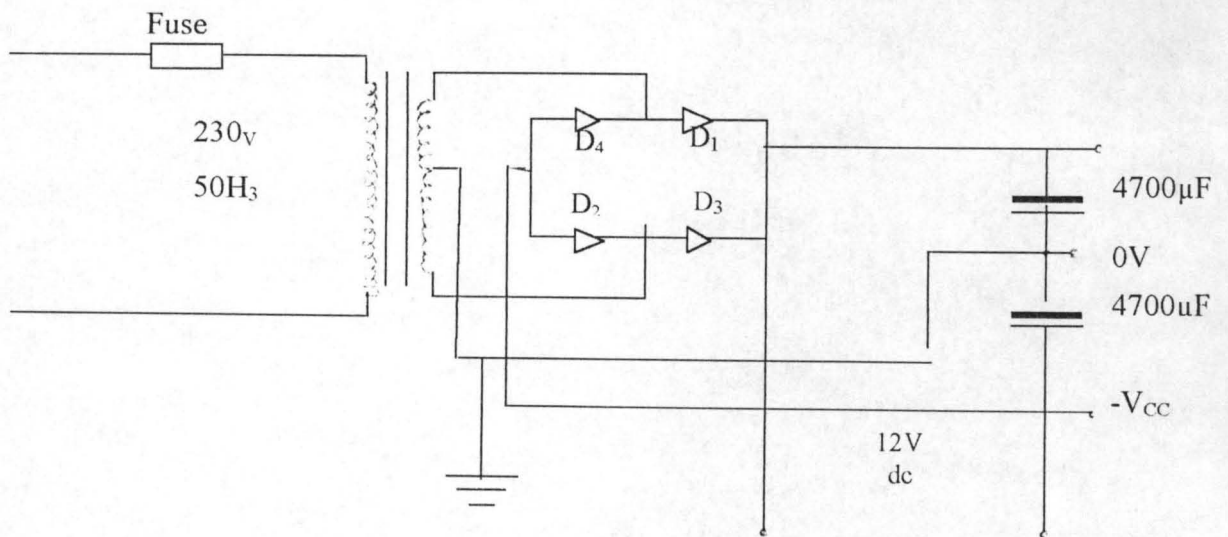

Fig. 3.4 Dual Power supply circuit.

The power supply unit (circuit) used for this project, consist of two parts; supply from the ac mains via the rectifier circuit and the automatic battery supply in the case of power failure from the ac mains.

## DC OUTPUT VOLTAGE OF POWER SUPPLY UNIT

Transformer used is centre-tapped.

Transformer turns ratio 8.1

Primary voltage = 230v ac

Root mean square (RMS) secondary voltage

$$= 230 \times \frac{1}{8} = 28.75\text{v}$$

Max voltage across secondary coil =  $28.75 \times 2$

$$= 40.65\text{v}$$

Max voltage appearing across half secondary coil

$$V_{in} = \frac{40.65}{2}$$

$$= 20.33\text{v}$$

Average current,  $I_{dc} = \frac{2V_m}{\pi R_L}$

Dc output voltage,  $V_{dc} = I_{dc} \times R_L$

$$= \frac{2V_m}{\pi} \times R_L$$

$$= \frac{2V_m}{\pi}$$

$$= \frac{2V_m}{\pi}$$

Dc output voltage,  $V_{dc} = 12.94\text{v}$

This dc output voltage is the voltage immediately after rectification without the presence of capacitor in the circuit.

### 3.1.4 VOLTAGE REGULATION

The voltage regulation of the power supply unit (circuit) is the degree to which a power supply varies in output voltage under load condition and when the supply is not on load i.e. not powering any external circuit. It is usually expressed as a percentage. (8).

$$\text{Percentage voltage regulation} = \frac{V_{NL} - V_{FL}}{V_{FL}} \times 100\%$$

Where  $V_{NL}$  = dc output voltage at no load

$V_{FL}$  = dc output voltage at full load.

The lower the percentage voltage regulation of the power supply unit, the more efficient is the power supply unit (circuit). The percentage voltage regulation of the power supply circuit shown in fig. 3.4 is given by

$$V_{NL} = 19.04\text{v}$$

$$V_{FL} = 18.42\text{v}$$

$$\% \text{ voltage regulation} = \frac{19.04 - 18.42}{18.42} \times 100$$

$$= \frac{0.62}{18.42} \times 100$$

$$= 3.3\%$$

This value shows that the power unit is efficient enough and can conveniently drive the amplifier.

### 3.2 CHARGING CIRCUIT

The charging circuit is majority made up of a Lm 317 series device. It uses fewer external component but charges very well. The value of  $R_1$  allows for a low charging rate with an overall effect of fully charging a battery.

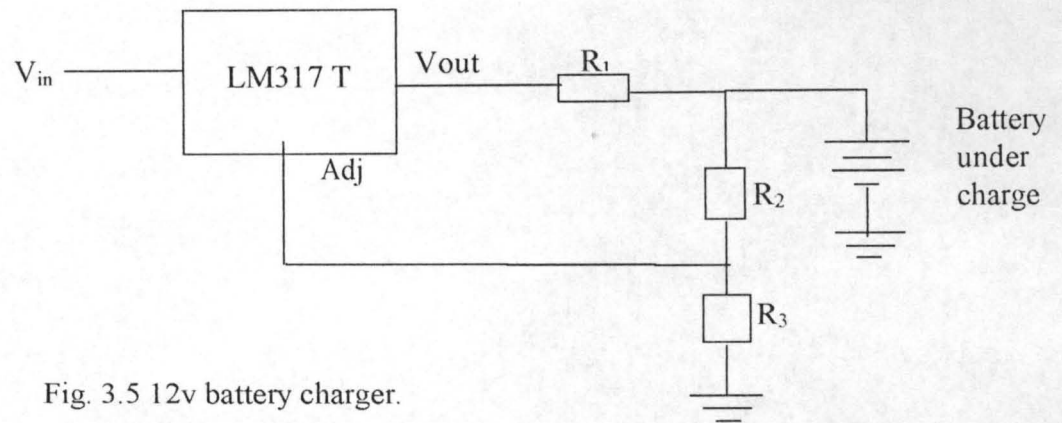

Fig. 3.5 12v battery charger.

Depending on the values of  $R_2$  and  $R_3$  with reference to internal adjustment in the Lm317T, the charging voltage and current can be varied. Resistor  $R_1$  sets the output impedance of the charger.

$$\text{Output impedance } Z_{out} = R_1 \left( 1 + \frac{R_3}{R_2} \right)$$

$$R_1 = 0.5 \Omega, R_2 = 200 \Omega, R_3 = 2.35k$$

$$Z_{out} = 0.5 \left( 1 + \frac{2350}{200} \right)$$

$$= 0.5 \times 12.75$$

$$Z_{out} = 6.375 \Omega$$

$$\text{Output voltage } V_{out} = 1.25v \left( 1 + \frac{R_3}{R_2} \right)$$

$$= 1.25 \left( 1 + \frac{2350}{200} \right)$$

$$= 1.25 \times 12.75$$

$$V_{out} = 15.94v$$

$$\text{Charging current } I_c = \frac{V_{out}}{Z_{out}} = \frac{15.94}{6.375} = 2.50A$$



### 3.3 CONSTRUCTION AND PACKAGING CONSTRUCTION

The constructional work of this Project covers the building of the amplifier circuit and the packaging of the built amplifier.

First the circuit components were laid on bread board for temporal operation of the amplifier and its related circuit (i.e power supply and battery charging circuits). This temporary operation is necessary in the constructional work as a means to ascertain for the proper functioning of all circuit and to also any fault detected.

Secondly, the circuit components were transferred unto a permanently and firmly fix each component on the board, and where applicable, jumper wires were used to ensure continuity between components. The power transistors used were mounted on heat sink to ensure that the transistor do not over-heat.

#### PACKAGING

The casing for the amplifier is of metal – sheet its dimension is given as.

Length  $L = 300\text{mm}$

Breadth  $B = 220\text{mm}$

Height  $H = 115\text{mm}$

Therefore, dimension of the amplifier packaging is 300mm x 220mm x 115mm.

The metal sheet was cut into different sizes following specification of measurement given above. Holes were drilled on the sheets using drilling machine. With these holes, the metal sheets are joined or fixed together. Holes (for ventilation) are drilled on the left and right hand side of the casing and at the top cover to provide path through which heat generated by the components (especially the power transistors) will escape to the outside. This is to minimize the heat within the casing.

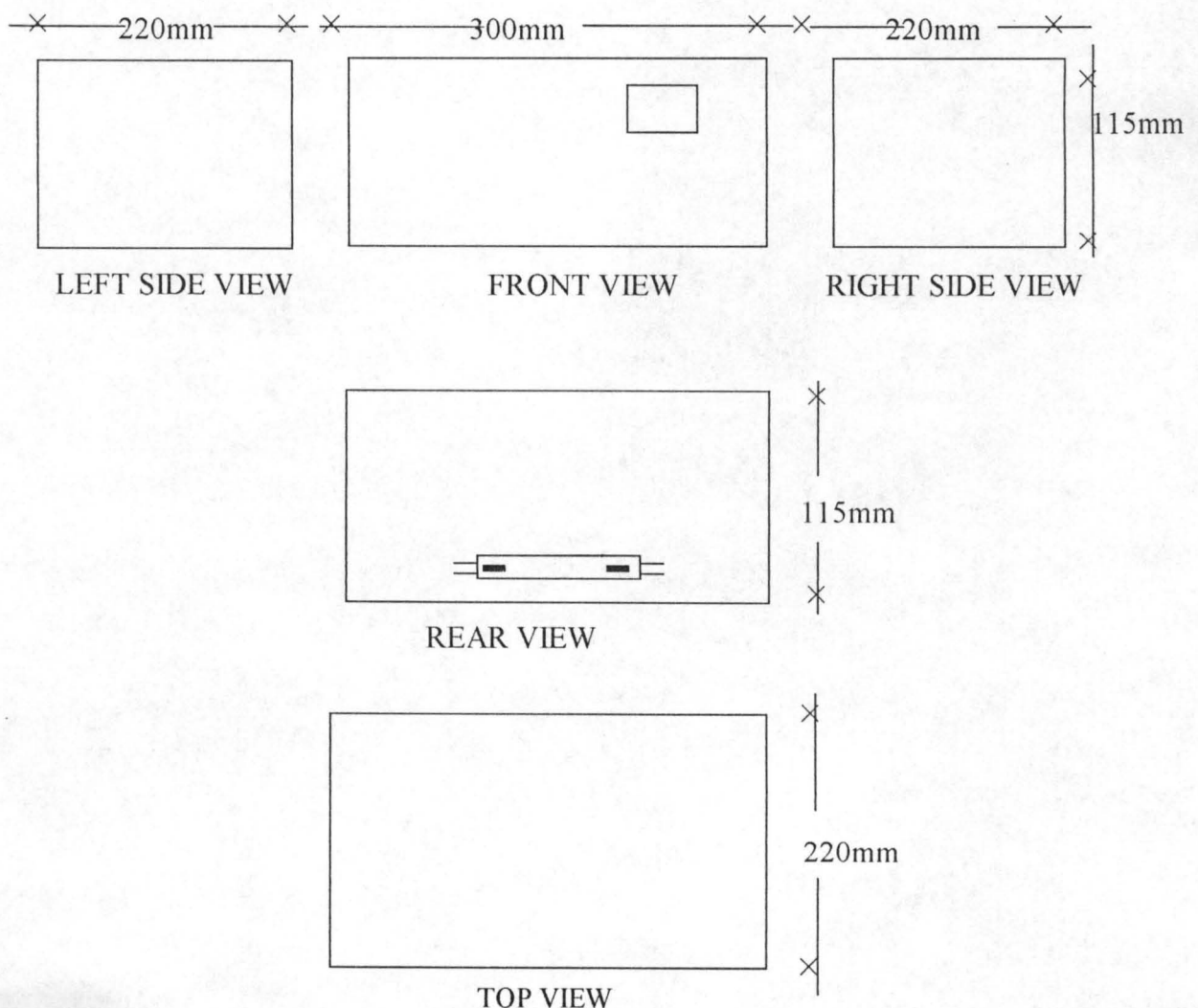

**Fig 3.6 Presentation of View of casing**

## **CHAPTER FOUR**

### **4.0 EVALUATION**

#### **4.1 TEST WITH POWER SUPPLY FROM THE MAINS (A.C)**

The final testing of the amplifier was carried out after the individual components have been permanently soldered into the Vero board. A loud speaker of 8 ohms resistance was used as the load while voice signal was fed in as input signal through a microphone. On regulating the volume control knob a clear and loud sound free of distortion was heard. The amplifier operates well with power supply from the main.

#### **4.2 TEST WITH BATTERY**

Testing the amplifier using battery power supply, involves connecting two 6v, 4.0 Ah batteries in series to get the 12v dc. Supply. Though sound produced was without distortion, but the intensity of the sound is not as high as when the amplifier was powered from the mains.

#### **4.3 TEST FOR AUTOMATIC POWER SWITCH-OVER AC-BATTERY**

This test was carried out when the amplifier was powered with supply from mains while the power supply from the battery was restricted from powering the amplifier with the help of relays.

The mains supply was switched off to indicate power failure, and this followed with an automatic switch-over as the relays were de-energized making contact and allowing the d.c supply from the battery to power the amplifier. Switching on the mains once again cuts off the d.c. Power supply as the relays were once again energized to break contact.

#### **4.4 CONCLUSION**

A public address system was achieved into which an additional automatic back-up power supply was incorporated. So far the project achieved its aim of designing a device with which large crowds could be addressed. Also the project has been able to reduce, if not totally eradicate the much delay encountered in connecting an external battery to power any public address system in the event of sudden power failure by the inclusion of an automatic back-up power supply.

#### **FEEDBACK AND ITS PREVENTION**

Feedback is an undesirable condition that occurs when amplified sound (usually from a speaker) is reintroduced into the microphone. The amplifier then tries to re-amplify the audio and it gets amplified over and over until all you hear is a loud squalling sound coming from the speakers. Careful placement of microphones and speakers can reduce feedback problems to a minimum.

The concept of feedback is actually is actually a hindrance to a clear understanding of signal outputs in a public address system. It is very important therefore, to address the problem.

First, always keep stage microphones behind the main house speakers, with the speakers directed out towards the audience. When a microphone moves in front of a speaker, it will pick up the sound being amplified and then "feed" that sound "back" through the amplifier, causing feedback.

When feedback occurs, or begins to occur, NEVER place your hand over the top of the microphone. It's a natural reaction, however, this makes feedback worse. The

faster way to stop feedback once it starts is either turn the main level down, or better yet, turn down the level of the offending microphone.

Then you can gradually raise your level and begin trouble shooting to find a suitable level adjustment.

#### 4.5 **LIMITATION**

Designing this project wasn't any easy task. Problems encountered during the cause of the design involved the inability to successfully source out for several of the components. This restricted the system to have just two sources of signal input i.e two microphone jack.

#### 4.5 **RECOMMENDATION**

It will be agreed that the project equally aimed at improving the overall working efficiency of the designed public address system. If consideration is given to this design, better and more efficient public address system could be attained.

To achieve this, the following recommendations are made.

- Silicon controlled rectifiers (SCR) should be used to replace the relays to effects change over of power supply from ac source to battery since it has high switching rate.
- More batteries (i.e. four batteries) or high power batteries should be used.
- More microphone jack should be included.

#### 4.7 APPENDIX A

##### SPECIFICATION OF TRANSISTOR USED

TIP 41C (NPN)

$I_C (\text{MAX}) = 6.0\text{A}$

$V (\text{BR})_{CE} = 100\text{V}$

$h_{FE} = 10\text{min j } 75 \text{ MAX}$

$I_{CBO} (\text{max}) = 700 \text{ NA}$

$P_D (\text{max}) = 65 \text{ W}$

2N3773 (NPN)

$I_C (\text{max}) = 16.0\text{A}$

$V(\text{BR})_{CE} = 140\text{V}$

$h_{fe} = 15 \text{ min j } 60 \text{ max}$

$I_{CBO} (\text{max}) = 2 \text{ m A}$

$P_D (\text{max}) = 150\text{W}$

TIP 42C (PNP)

$I_C \text{ MAX} = 6.0\text{A}$

$V (\text{BR})_{CE} = 100\text{V}$

$h_{fe} = 10\text{min j } 75 \text{ max}$

$I_{CBO} (\text{max}) = 700 \text{ Na}$

$P_D (\text{max}) = 65 \text{ W}$

MJ 2955 (PNP)

$I_C (\text{max}) = 15.0\text{A}$

$V(\text{BR})_{CE} = 60\text{V}$

$h_{fe} = 15 \text{ min j } 70 \text{ max}$

$I_{CBO} (\text{max}) = 700 \text{ NA}$

$P_D (\text{max}) = 115\text{W}$

## APPENDIX B

### 4.8 LIST OF COMPONENTS USED

#### AMPLIFIER CIRCUIT

COMPONENTS	QUANTITY/NOMENCLATURE	VALUE
------------	-----------------------	-------

#### A RESISTORS

R1, R3	2, carbon resistor	10k
R2	1, carbon resistor	33k
R4	1, carbon resistor	1k
R5	1, carbon resistor	150 $\Omega$
R6, R7	2, carbon resistor	47 $\Omega$
R8, R9	2, carbon resistor	47 $\Omega$
R10 – R13	4, carbon resistor	120 $\Omega$
VR1 – VR2	2 potentiometer	50k
VR3	1 potentiometer	100k
VR4-VR5	2 potentiometer	10k

#### b. CAPACITORS

c1, c7	2, electrolytic	1 uf/50v
c2, c6	2, electrolytic	10uf/16v
c3, c5, c8	3, non-electrolytic	0.05uf
c4	1, non-electrolytic	0.03uf

c. **TRANSISTOR**

Q1	1, NPN	TIP 41C
Q2	1, PNP	TIP 42C
Q3	1, NPN	2N 3773
Q4	1, PNP	MJ 2955

d. **INTEGRATED CIRCUIT**

1C1	1, OP – Amp	UA 741
1C2	1, OP – Amp	JRC 4558D

**Power supply circuit**

TR1	1, Ac transformer	240v/30v (Centre-tapped)
BR1	1, Bridge rectifier	D 35 Ba 10
C9, C10	2, electrolytic	4700 uf/35v

**RELAY CIRCUIT**

TR2	1, Ac transformer	240/30v (center-tapped)
BR2	1, Bridge rectifier	BAA20
C3	1, electrolytic	100uf/25v
C4, C5	1, electrolytic	10uf/16v
ICI	1, Voltage regulator	CUE 7812 C
RLY 1 and 2	2, 12v relay	10 ADC 12V



## CHARGING CIRCUIT

D1 – D4	4, Silicon diodes	IN4001
C6	1, electrolytic capacitor	1000 uf/25v
lcl	1, voltage regulator	Lm317 T
R1	1, wire wound resistor	0.5
R2	1, carbon resistor	240
R3	1, carbon resistor	2.4k
R5	1, carbon resistor	1k

## REFERENCE

1. Boylestad, R. and L. Nashelky (1996). Electronic Devices and Circuit Theory (6<sup>th</sup> edition). Prentice – Hall, Inc. New Jersey. Pp 701 – 740.
2. Cirovic, M. M. (1974). Basic Electronics Devices, Circuits and systems. Reston publishing company. Inc. Virginia pp 115 – 218.
3. Green, D.C. (1985). Electronics III (3<sup>rd</sup> edition). Pitman publishing Limited. New Zealand. Pp 99 – 106.
4. Green D.C. (1981). Electronics TEC Level IV. Pitman Books LTD, New Zealand, pp 119 – 143.
5. Horowitz, P. and W. Hill (1995). The Art of Electronics (2<sup>nd</sup> edition). University Press, Cambridge Britain. Pp 175 – 178.
6. Maddock, R.J. and D. M. Calcutt (1994). Electronics A Course for Engineers (2<sup>nd</sup> edition). Longman Group LTD, Singapore. Pp 448 – 456, 633 – 645.
7. Mehta, V. K. (1998). Principle of Electronics. S. Chad and Company LTD. New Delhi. Pp 244 – 316.
8. Mottershead, A. (1989). Electronics Devices and Circuit an Introduction. Prentice – Hall, Inc. London. Pp 20 – 26, 339 – 348.
9. Muhammad, H. R. (1988). Power Electronics Circuits Devices and Application (2<sup>nd</sup> edition). University press, Cambridge, Britain Pp 175 – 178.
10. Waterworth, G. (1988). Work out Electronics. Macmillan education LTD. London. Pp 115 – 119, 190 – 192.

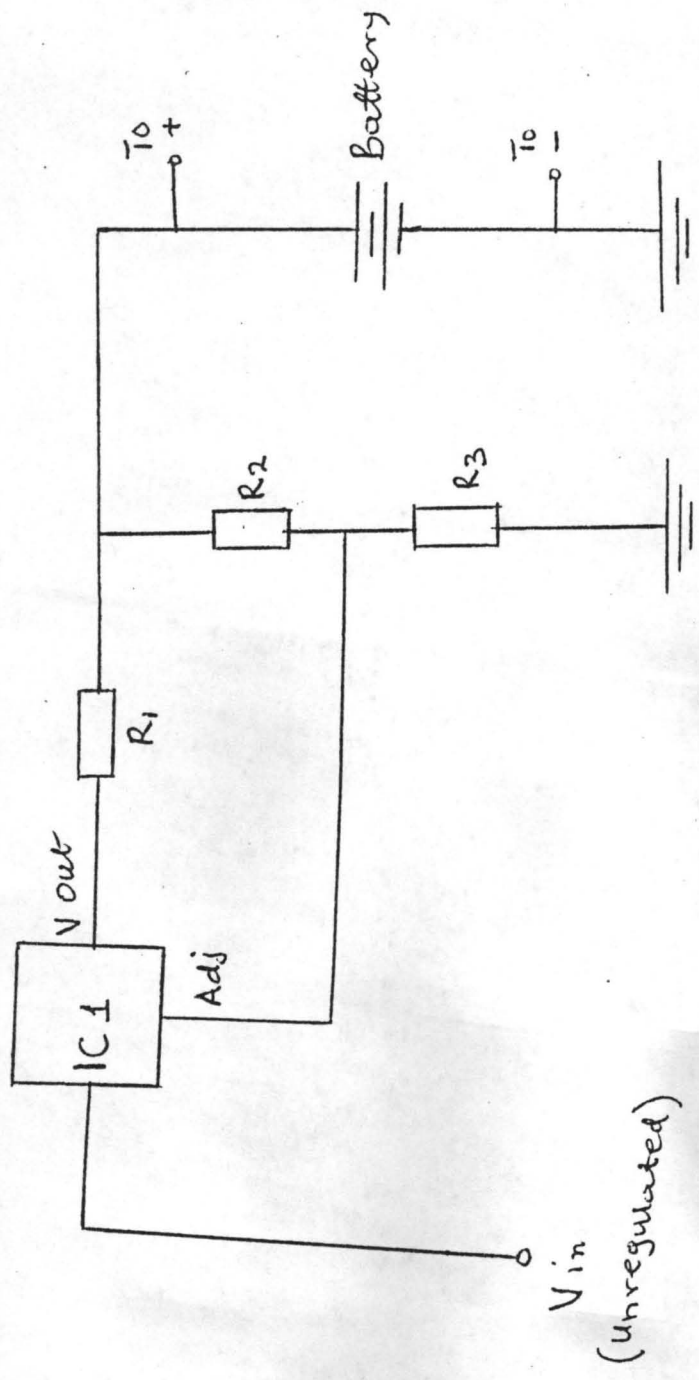

Charger