

DESIGN AND CONSTRUCTION OF A SINGLE PHASE CHANGE-OVER SWITCH

**IDRIS MAHMODD
(2004/18835EE)**

**DEPARTMENT OF ELECTRICAL AND COMPUTER
ENGINEERING**

DECEMBER, 2009

DESIGN AND CONSTRUCTION OF A SINGLE PHASE AUTOMATIC CHANGE- OVER SWITCH

BY

**IDRIS MAHMOOD
2004/18835EE**

**A Thesis submitted to the Department of Electrical and
Computer Engineering, Federal University of Technology,
Minna**

DECEMBER, 2009

DEDICATION

This work is dedicated to Almighty Allah, who has been the source of my inspiration, the source of all knowledge both open and hidden in this world and in the world after. I also dedicate this work to my late mother Mallama Fati, my late step mother Mallama Fatima Mahmood and my father Alhaji Mahmood Sani B. whose moral and financial contribution cannot be overestimated. May the Almighty Allah reward them all with Aljannah Firdaus. ameen.

DECLARATION

I, Idris Mahmood, declare that this work was done by me and has never been presented elsewhere for the award of a degree. I also hereby relinquish the copyright to the Federal University of Technology, Minna.

Idris Mahmood
(Student)

 14/01/2010

(Signature and Date)

Mr. Michael David
(Supervisor)

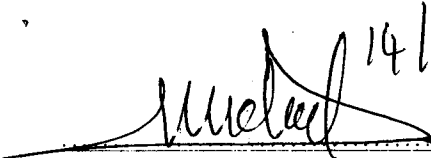
 14/01/2010

(Signature and Date)

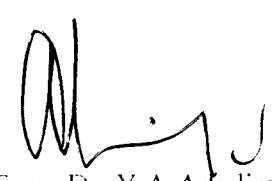
Engr. Dr. Y.A Adediran
(Head of Department)

For: 
May 6, 2010

(Signature and Date)

DR. (Mrs.) D. A. ADKHBANK
External Examiner

 04/03/10

(Signature and Date)

ACKNOWLEDGEMENT

My utmost gratitude goes to Allah, my nourisher and sustainer. He gives me life and makes everything possible for me. To my dear father Alhaji Mahmood Sani B. my step mothers Hajiya Fati and Hajiya Ladidi Mahmood for their greatest support. My sincere gratitude also goes to my siblings Amina, Hamza, Zubairu, Zubairu B. Aminu, Nuhu, Ranaatu, Maryam, Farida, Suleiman, Munir and Zahra Mahmood for their general assistance in all my life endeavours.

This acknowledgement can never be complete without appreciating the tremendous effort my supervisor Mr. Michael David has made to see to the success of this project. His supervisory guidance has really contributed immensely to the success my work as he had enriched my colleagues and I with his wealth of knowledge and experience from the day one just to make sure that we finish our projects successfully. His constructive criticism dissatisfaction with whatever little we offer really gave us the push we needed to work very hard towards the actualization of our objectives. My profound gratitude goes to all my lecturers for the knowledge that they have impacted in me right from my 100leve up to this day.

I will not forget the tremendous help from my colleagues in school such as Adamu Mohammed, Adamu Shaba, Muhammad Awwal Hasheem, Mohammed Alfa, Habibu Hussein just to mention but a few. God bless you.

ABSTRACT

This project seeks to eliminate the dangers associated with manual change-over process in our homes by making the process automatic. In addition to the change-over unit, it also incorporates mains over voltage protection unit and generator delay unit. The main input from PHCN is fed into the mains over voltage protection unit. The output of this unit serves as input to the engine switch which switches off the generator, and the change-over unit which serves the load. Under over voltage condition, the over voltage protection unit relay is operated thereby cutting off the engine switch and the change-over unit from mains supply. Thus both the engine switch components and the load are protected from the mains over voltage supply. Upon mains failure the engine switch relay switches 'on' the generator. When the generator is manually started, the delay unit will cause a delay of seven 7 seconds to allow the generator attain full speed before the change over relays will finally place the generator on load. Due to components' tolerance the actual delays recorded for a number of 10 tests ranged between 9.5 and 12.7 seconds. The changeover process as well as the switching off of the generator are automatic but actual starting of the generator upon mains failure is to be done manually.

TABLE OF CONTENTS

	PAGES	
TITLE PAGE .	I	
DEDICATION	II	
DECLARATION	III	
ACKNOWLEDGEMENT	IV	
ABSTRACT	V	
Chapter One: Introduction		
1.1 Introduction.....	1	
1.2 Motivation.....	1 - 3	
1.3 Aims and objectives.....	3	
1.4 Methodology.....	3 - 4	
1.5 Scope.....	4	
1.6 Organization of Thesis.....	5	
Chapter Two: Literature Review.....		6
2.1 Changeover Switch.....	6	
2.1.1 Manual Switch.....	6 - 7	
2.1.2 Automatic Switch.....	7 - 9	
2.2 Protection.....	9	
2.3 Delay Timer.....	9	
2.4 Power Supply.....	10	

2.4.1	Mains Utility Power Supply.....	10
2.4.2	Generator Power Supply.....	10
2.5	Review on 555 Timer.....	11
2.5.1	the Pins of 555 Timer.....	11 – 13
2.5.2	Operating Mode.....	13
2.5.3	Astable Operation.....	13 – 17
2.5.4	Output of 555	17
2.6	Review on Relays.....	17 – 18
2.6.1	How Relays Work.....	18 – 19
Chapter Three: Design and Construction.....		20
3.1	Auto Over Voltage Protection.....	20
3.1.1	triac.....	20
3.1.2	220v AC relay.....	21- 22
3.2	Engine Switch.....	22
3.3	Auto Changeover Switch.....	23
3.4	Delay Circuit.....	24
3.4.1	555 Timer.....	24
3.4.2	555 Timer Selection.....	24
3.4.3	Sinking and Sourcing.....	24-26
3.4.4	Delay Timer Calculation.....	26
Chapter Four: Test, Result And Discussion of Result.....		27
4.1	Test.....	27 – 28
4.2	Results.....	28

4.3	Problems Encountered.....	29
4.4	Discussion Of results.....	29
Chapter Five: Conclusions and Recommendations.....		30
5.1	Conclusions.....	30
5.2	Recommendations.....	31
	Reference.....	32
	Appendix.....	33

LIST OF FIGURES

Figure 2.1	Circuit Block Diagram.....	8
Figure 2.2	Pin-Out of the 555	12
figure 2.3	Astable Multivibration Wave Form.....	14
figure 2.4	Astable Circuit With Diode Across R_2	16
figure 2.5	555 Sinking and Sourcing Current.....	17
figure 2.6	Mechanical Operation of a Relay.....	18
figure 3.1	Triac Symbol.....	20
figure 3.2	220v AC Relay as the over voltage relay.....	21
figure 3.3a	Normal Voltage Condition.....	21
figure 3.3b	Over Voltage Condition.....	21
figure 3.4a	6v dc Relay as Engine Switch Relay.....	22
figure 3.4b	Engine Switch Unit.....	22
figure 3.5	Change Over Relays in Parallel.....	23
figure 3.6	555 Timer Circuit Symbol.....	24
figure 3.7	555 Sinking and Sourcing Current.....	25

figure 3.8 Circuit Diagram of Time Delay Unit.....26
figure 5.9 Complete Circuit Diagram.....33

LIST OF TABLES

table 4.1 Measured Time And the Calculated Time Delay.....28

CHAPTER ONE

INTRODUCTION

Generally, changeover or transfer switches allow switching from a primary source to a secondary or tertiary power source and are employed in some electrical power distribution system. Most often transfer/changeover switches can be seen where emergency power generators are used to backup power from the utility source. The changeover switch allows safe switching from utility power to the emergency generator power while maintaining isolation of generator source from the other. The switch may be manual, automatic, or a combination of manual and automatic.

In a home during a power outage, for example, the changeover switch allows the isolation of the owner's critical circuits (e.g. cooling, refrigerator, lighting) from the utility service allowing for operation of the generator without back feeding to the utility which can damage utility equipment and hurt (or kill) utility workers.

A transfer switch can be set up to provide power to only critical circuits or entire electrical (sub) panels. Some transfer switches allow for load shedding or prioritization of optimal circuits such as heating and cooling [1].

1.1 MOTIVATION

Regular power supply is the prime mover of social and technological development. There is hardly any enterprise or indeed any aspect of human development that does not require energy in one form or the other – electric power, fuels, e.t.c. It is very sad, indeed, that we live in a country that is richly endowed with various energy sources: crude oil, natural gas, coal, hydropower, solar energy, fissionable materials for nuclear energy yet the country consistently suffer from energy shortage – a major impediment to industrial and technological

growth [2]. Mr. Gordon a former General Manager of the tenniss valley authority in the United State of America (U.S.A.) once said "if you want to destroy a region, you destroy its power supply, if you would hold a region to a lower standard of living, you can do it by placing a limit on its supply of electric power". The power Holding Company of Nigeria, PHCN, government parastatal that has the sole responsibility for managing the generating plants as well as distribution of power nationally has failed to live up to its expectation as its performance has translated into uncountable woes for the people. From the East to the West, North and South of the country, Nigerians have continued to bemoan their fate in the hands of PHCN [3].

This epileptic power situation has caused a lot of discomfort in many homes. Important programs such as TV programs, ceremonial occasions to mention but a few are often interrupted. Businesses are also not left out of this menace; as it causes a great deal of costs, loss and delay in keeping to agreement between business men and their clients as well as distrust, and suspicion.

At times light goes off for more than 10 or 5 times a day [3]. This means that individuals will have to acquire generating sets in order to enjoy the comfort of their homes and to remain in business or functional they are left with the painful choice of generating their own power. This means that they have to acquire generating sets.

Now, if Nigerians are left with the option of purchasing generating sets and fuelling these generators which are respectively expensive, it is therefore pertinent on them to make the maximum possible benefit out of the difficult situation. This means that the generator must not be allowed to run one extra minute whenever the public utility is restored. This will ensure that the fuel is not allowed to waste whenever there is power from PHCN. Hence fuel is saved and an ineffective cost (i.e. PHCN bill) that occurs mostly during the night when

there is no body to notice the return of power from PHCN is made effective to an extent as the generator will not run unnecessarily. This will in addition, also prolong the generator's life span. This is the motivating factor behind my selection of the topic 'Automatic Change Over Switch'.

The design of the switch is such that the generator will only run when there is power outage and automatically stop running immediately power is restored and as well place the load on the utility mains supply.

1.2 AIMS AND OBJECTIVES

1. To eliminate the risk involve in going near the changeover Panel.
2. To minimize changeover time and make it less tasking
3. To minimize fuel wastage
4. To prolong generator's life span

1.3 METHODOLOGY

Various methods are adopted in the design of changeover switches depending of the desired output. Some of the methods are: Break before make system , which prevents back-feeding from an emergency generator back into the utility line; Closed Transition Transfer Switch (CTTS), which involves transfer from one available source to another during a test or re-transferring to normal after primary power has stabilized (transfer occurs in this case for reasons other than a total loss of power); Soft Loading Transfer Switch (SLTS). which essentially uses CTTS technology but actively changes the amount of load accepted by the generator[1].

Functional block design method is adopted in the design of this project. Each block of the block diagram (see fig.2.1) is examined in detail viz avis the its function. There after the

interfacing of this functional blocks follows. At this stage some necessary adjustment are also accomplished. For the purpose of control and harmonious interaction between this blocks, basic parameters such as voltage, currents and resistance are adjusted in the interfaces where necessary. This way some sensitive components are saved from damage. The examples below explain better.

- Generator Supply and the Delay Timer: After the rectification and smoothening of the generator supply limiting resistor comes in between the supply and the 555 timer to limit the current to the 555 timer IC's operating current.
- Delay Timer and the Changeover relays: A free wheeling diode is connected in between the 555 timer IC and the relays such that it protects the IC from the back emf produced by the relays whenever they demagnetizes.

1.4. SCOPE

This mains change over switch is designed to handle one phase system and mainly for domestic application. It switches off the generator automatically upon the return of Power from the utility supply and 'on' the Engine switch. However actual starting of the generator is manual. Only the changeover is automatic.

The major components used are Relays, transformers, 555 timer IC. Others are diodes, resistors, capacitors, diodes e.t.c. The transformers steps down 220v a.c. to 12 or 6vd.c as the case may be. While the relays act as switches the 555 timer IC function as delay circuit. Other components are used in conjunction with the major components to assist them work properly according to the desired pattern, and also as protective devices.

1.5. ORGANIZATION OF THESIS

The next chapter which is chapter three deals with the literature review on this project topic and some basic components used in its implementation. Chapter three is the design and implementation – in this chapter (3) logical implementation of the project is adopted as each unit (namely: over voltage unit, the supply unit, the change over unit, engine switch and the delay unit) is examined in detail. At the end of each unit the diagram is drawn before proceeding to the next unit. Calculations are done as well.

Chapter three talks about the test and results obtain at the end of the construction. Difficulties and reasons for variations in the results obtained as compared to the theoretically expected results were stated.

Finally, conclusions and recommendations summed it up in the chapter four.

CHAPTER TWO

LITERATURE REVIEW

Since about 1879 when Thomas Edison invented Electric bulb, man has not relented in his endeavour to find other uses for electricity. He has used it as a labour saving device in agriculture, in medicine and in industry, for comfort and for preservation in the home, and indeed for satisfaction of the widest possible spectrum of human need. In all that versatility of electric power has given him greatest dominance he now exercise over his environment.

So man has continued in his inventions and innovations which is more or less like a live project – inventions and innovation.

2.1 CHANGE OVER SWITCH

A change over switch as defined by Mc Graw Hill Dictionary of Science and Technology Terms is “A means of moving a circuit from one set of connections to another” [4]

2.1.1. Manual Switch

This utilizes the system of switch gear. A Break before Make changeover switch breaks contact with one source of power before it makes contact with another. A non conducting bar is connected to the handle that is turned between three positions with the utility power on one side, the generator on the other side and “off” in the middle which requires the user to switch through the full disconnect “off” position before making the next connection [1].

The generator does however need time to get up to speed before the manual changeover switch can be placed on “Generator”. The recommended time for this is between 5 to 10 seconds.

The use of manual switch could be tasking and time consuming as it involves use of physical

energy thus making it difficult to operate at times. More so, operating manual changeover switch could be very dangerous as it is live threatening.

2.1.2 Automatic Switch

The automatic changeover switch takes care of the disadvantages of the manual changeover switch. This is because it removes physical interference in the changeover process

a. Fully Automated Changeover Switch

Automatic transfer switch or better still fully automated system of transfer switch is one in which the switch continually monitors the incoming utility power. Any anomalies such as voltage sags, power outage, brownouts, spikes or surges will cause the internal circuitry to command a generator to start and will then transfer the load to the generator when additional switch circuitry determines the generator has the proper voltage and frequency. When the utility power returns or no anomalies have occurred for a set time, the transfer switch will then transfer back to the utility power and command the generator to turn off [1].

b. Semi Automated Change Over Switch

This is a combination of manual and automatic switching system. It is important, at this point, to mention that this is the method adopted in the design of this project. The title of this project 'Automatic Change Over Switch'. Note the underlined word 'Change Over' as it is the changing over from utility to generator and vice versa that is automatic, and not the actual Starting of the generator. Hence turning the key to the 'Start' position or pushing the 'start button' as the case may be is required to get the generator started.

Fig 2.1 shows the block diagram of the change over switch. Upon mains active the changeover switch will be in off position there by connecting the load to the mains supply

provided the mains supply is not over voltage otherwise the auto voltage protector relay will be active thereby disengaging the house from utility mains supply. The change over relays will pull the load to the generator whenever there is power outage from the mains utility and the generator will be powered 'on'. Immediately the mains fail, the changeover switch will still hold the load down to the mains (while the generator is powered 'on') in assumption that power will return and will remain in that state until the generator is started. The 'DELAY' is there to allow the generator to warm up before connecting it to the load. Note that immediately mains fail the generator is switched on automatically, and will also be stopped automatically too by the return of mains. Since the changeover switch (made up of relays) is generator powered which is now off due to return of mains supply (PHCN), it will have no option but to pull load to the mains and the circle of operation continues in that order.

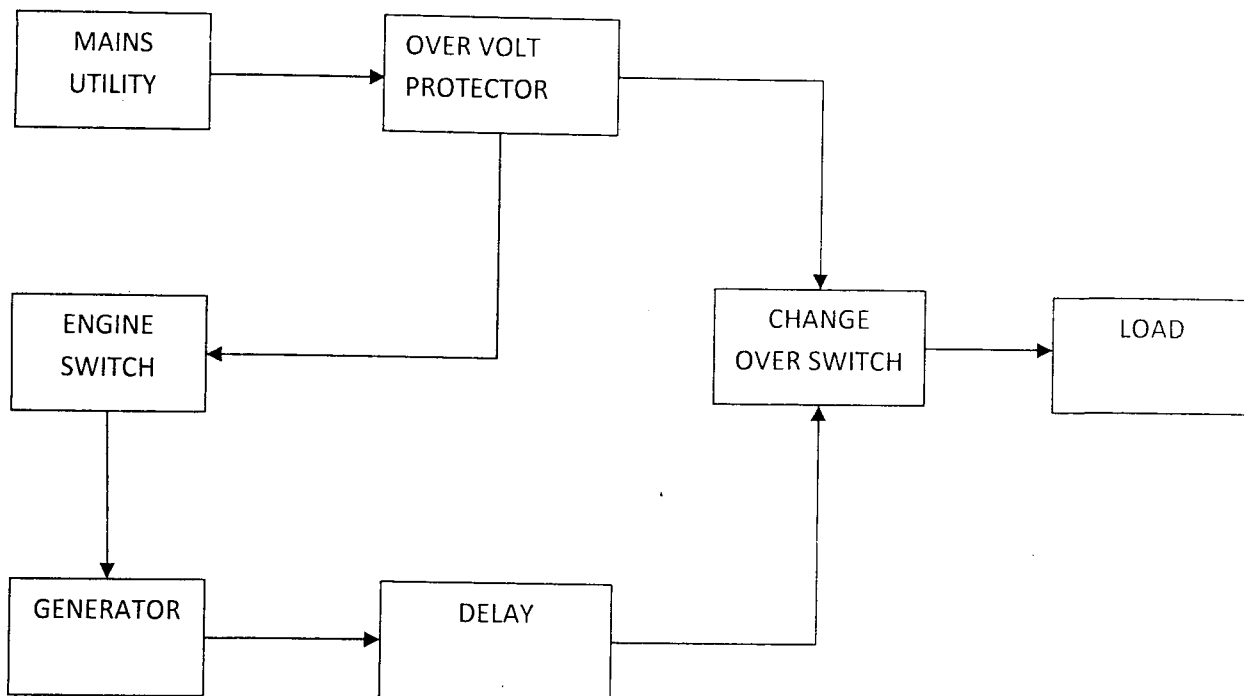

Fig 2.1 Block Diagram

Ajayi Lawrence Oluwatimilehim 2004/15308 carried out similar project in the 2007/2008 academic session. In his project design he failed to take cognisance of the fact that the

Generating set needs to run for at least five seconds in order for it to attain full speed before placing it on the load. This is a set back as the generator is bound to go off if it is loaded almost immediately after it is started.

2.2. PROTECTION

In every electrical and electronics equipment the issue of protection can not be over emphasized. Even though every house with proper electrical wiring must have a protection device that is the Earth Leakage Circuit Breaker (ELCB) which trips off in case there is a fault, the design of this project also incorporate a protection device that protects the house from over voltage. The auto over voltage protection unit is designed to protect the house from over voltage from mains utility supply as much as it protects some of the components in the circuit. The engine switch whose function it is to switch off the generator upon the return of mains supply is composed of a 220v/6v AC step down transformer. This transformer is also been protected by the auto over voltage unit. Note that this protective device is not protecting components been powered by the generator. This is so because it is almost impossible for the generator to supply over voltage as generators incorporate AVR (automatic voltage regulator).

2.3. DELAY TIMER

The 555 timer is incorporated in this circuit to cause a delay of about 10 seconds for the generator to attain full speed whenever it is started before placing it on the load. This will prevent the generator from prematurely going off after start up and also optimize its performance and prolonging its life span as well.

2.4. POWER SUPPLY

The design of this switch is such that it takes its power from two sources namely the generator source and mains utility (PHCN) source. The connection of the changeover relays are such that the common terminal (C) is connected to the load while the normally close terminal (NC) is connected to the mains utility (PHCN) supply and the generator is connected to the normally open terminal (NO). Thus the common terminal which is connected to the load toggles between PHCN and Generator depending on the power condition of the changeover relays.

2.4.1. Mains Utility Power Supply

The supply from the PHCN after passing through the auto over voltage unit undergoes rectification and smoothening and finally goes to the engine switch to switch off the generator. Hence changeover relays are de-energised (demagnetised) and the common (load) is released to the normally close terminal (PHCN). In other word the load is placed on mains utility supply.

2.4.2. Generator Power Supply

The changeover relays are always in the un-magnetized state pending when the generator is started. The moment the generator is started the supply from the generator that is to go to the load (C) remains at the Normally Open terminal. The supply is first of all tapped after which it is stepped down by the transformer from 220v/12v AC then rectified by the bridge diode rectifier, after which it is smoothened by the filter capacitor. The filtered voltage is then taken to the 555 timer which will cause a delay of about 10 seconds before powering the changeover relays. Immediately current passes through the relays they become magnetized and the the load (C) moves to the Generator (NO).

2.5. REVIEW ON 555 TIMERS

The 555 Timer IC is an integrated circuit (chip) implementing a variety of timer and multivibrator applications. The IC was designed and invented by Hans R. Camenzind. It was designed in 1970 and introduced in 1971 by Signetics (later acquired by Philips). The original name was the SE555/NE555 and was called "The IC Time Machine".[5] The 555 gets its name from the three 5-kohm resistors used in typical early implementations.[6] It is still in wide use, thanks to its ease of use, low price and good stability. As of 2003, 1 billion units are manufactured every year.

Depending on the manufacturer, it includes over 20 transistors, 2 diodes and 15 resistors on a silicon chip installed in an 8-pin mini dual-in-line package (DIP-8).[5]

The 556 is a 14-pin DIP that combines two 555s on a single chip.

The 558 is a 16-pin DIP that combines four slightly modified 555s on a single chip (DIS & THR are connected internally; TR is falling edge sensitive instead of level sensitive).

Also available are ultra-low power versions of the 555 such as the 7555 and TLC555.[7] The 7555 requires slightly different wiring using fewer external components and less power.

2.5.1. The Pins of the 555

First, we need to know what the 555 looks like. It has eight connections (called pins) to its plastic case, arranged as four on one side and four on the other, as shown in the pin-out diagram of figure 2.2. From this diagram, you can see that pin 1 is the pin on the bottom left when the IC is held horizontal with the writing the correct way up. The little notch in one side also helps to identify pin 1, as does the small white dot next to this pin.

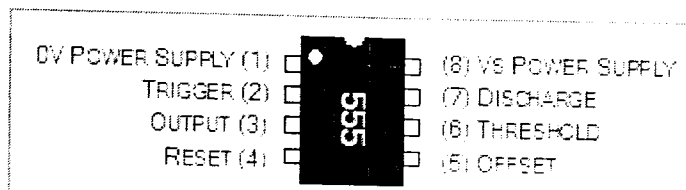

Fig. 2.2 Pin-out of the 555

The Power Supply

Pin 8 is where you connect the positive power supply (V_s) to the 555. This can be any voltage between 3V and 15V DC, but is commonly 5V DC when working with digital ICs.

Pin 1 is the 0V connection to the power supply.

Trigger and Reset Inputs

Pin 2 is called the Trigger input as it is this input that sets the output to the high state. Pin 4 is called the Reset input as it is this input that resets the output to the low state. Both pins may be connected to push buttons to control the operation of the 555. Sometimes the Reset input is not used in a circuit, in which case it is connected directly to V_s so that unwanted resetting cannot occur.

Threshold and Discharge

Pins 6 and 7 (and sometimes the Trigger input, pin 2) are used to set up the timing aspect of the 555 IC. They are normally connected to a combination of resistors and a capacitor.

Offset

Pin 5 can be used to alter the timing aspect of the 555 IC in applications such as frequency modulation. Usually this function is not required and the control input is connected to 0V with a $0.01\mu\text{F}$ capacitor to eliminate electrical noise. It can be left unconnected if noise is not a problem.

Output

Pin 3 is the digital output of the 555. It can be connected directly to the inputs of other digital ICs, or it can control other devices with the help of a few extra components.[8]

2.5.2. Operating Modes

The 555 has three operating modes:

- Monostable mode: in this mode, the 555 functions as a "one-shot". Applications include timers, missing pulse detection, bouncefree switches, touch switches, Frequency Divider, Capacitance Measurement, Pulse Width Modulation (PWM) etc
- Astable - Free Running mode: the 555 can operate as an oscillator. Uses include LED and lamp flashers, pulse generation, logic clocks, tone generation, security alarms, pulse position modulation, etc.
- Bistable mode or Schmitt trigger: the 555 can operate as a flip-flop, if the DIS pin is not connected and no capacitor is used. Uses include bouncefree latched switches, etc.[9]

2.5.3. Astable operation

With the output high (+Vs) the capacitor C1 is charged by current flowing through R1 and R2. The threshold and trigger inputs monitor the capacitor voltage and when it reaches $\frac{2}{3}V_s$ (threshold voltage) the output becomes low and the discharge pin is connected to 0V.

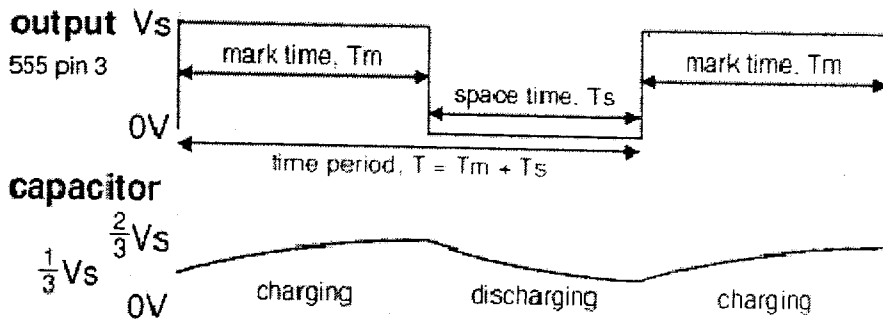

Fig. 2.3. Astable multivibrator wave form

The capacitor now discharges with current flowing through R2 into the discharge pin. When the voltage falls to $\frac{1}{3}V_s$ (trigger voltage) the output becomes high again and the discharge pin is disconnected, allowing the capacitor to start charging again.

This cycle repeats continuously unless the reset input is connected to 0V which forces the output low while reset is 0V.

An astable can be used to provide the **clock signal** for circuits such as counters.

A **low frequency** astable ($< 10\text{Hz}$) can be used to flash an LED on and off, higher frequency flashes are too fast to be seen clearly. Driving a loudspeaker or piezo transducer with a low frequency of less than 20Hz will produce a series of 'clicks' (one for each low/high transition) and this can be used to make a simple metronome.

An **audio frequency** astable (20Hz to 20kHz) can be used to produce a sound from a loudspeaker or piezo transducer. The sound is suitable for buzzes and beeps. The natural (resonant) frequency of most piezo transducers is about 3kHz and this will make them produce a particularly loud sound.

Duty cycle

The duty cycle of an astable circuit is the proportion of the complete cycle for which the output is high (the mark time). It is usually given as a percentage.

For a standard 555/556 astable circuit the mark time (T_m) must be greater than the space time (T_s), so the duty cycle must be at least 50%:

$$\text{Duty cycle} = \frac{T_m}{T_m + T_s} = \frac{R_1}{R_1 + R_2}$$

To achieve a duty cycle of less than 50% a diode can be added in parallel with R_2 as shown in the diagram. This bypasses R_2 during the charging (mark) part of the cycle so that T_m depends only on R_1 and C_1 :

$$T_m = 0.7 \times R_1 \times C_1 \quad (\text{ignoring } 0.7V \text{ across diode})$$

$$T_s = 0.7 \times R_2 \times C_1 \quad (\text{unchanged})$$

$$\text{Duty cycle} = \frac{T_m}{T_m + T_s} = \frac{R_1}{R_1 + R_2}$$

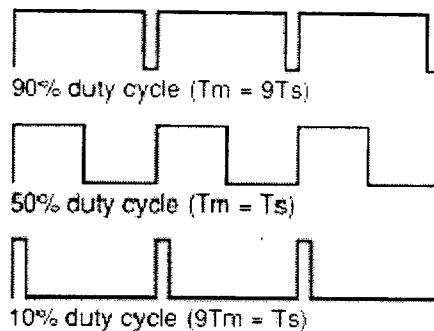

Fig. 2.4 Square Waves Showing Duty Cycles

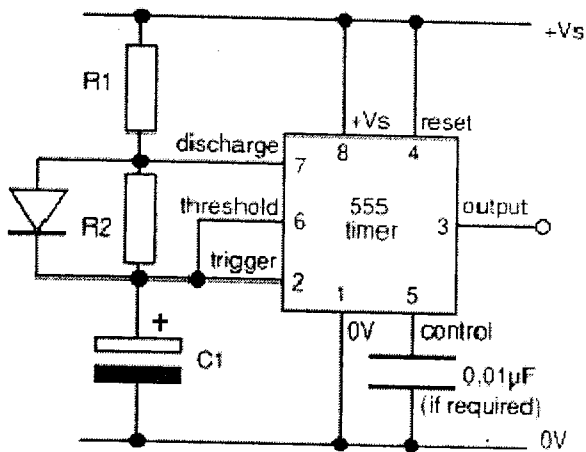

Fig. 2.5. 555 astable circuit with diode across R2

The time period (T) of the square wave is the time for one complete cycle, but it is usually better to consider frequency (f) which is the number of cycles per second.

$$T = 0.7 \times (R1 + R2) \times C1 \text{ and } f = \frac{1.4}{(R2 + 2R2) \times C1}$$

T = time period in seconds (s)

f = frequency in hertz (Hz)

R1 = resistance in ohms (Ω)

R2 = resistance in ohms (Ω)

C1 = capacitance in farads (F)

The time period can be split into two parts: $T = T_m + T_s$

Mark time (output high): $T_m = 0.7 \times (R1 + R2) \times C1$

Space time (output low): $T_s = 0.7 \times R2 \times C1$

Many circuits require T_m and T_s to be almost equal; this is achieved if $R2$ is much larger than $R1$.

For a standard astable circuit T_m cannot be less than T_s , but this is not too restricting because the output can both sink and source current. For example an LED can be made to flash briefly with long gaps by connecting it (with its resistor) between $+V_s$ and the output. This way the LED is on during T_s , so brief flashes are achieved with R_1 larger than R_2 , making T_s short and T_m long. If T_m must be less than T_s a diode can be added to the circuit as explained under duty cycle above.

2.5.4. Output of 555

The output of a standard 555 or 556 can sink and source up to 200mA. This is more than most ICs and it is sufficient to supply many output transducers directly, including LEDs (with a resistor in series), low current lamps, piezo transducers, loudspeakers (with a capacitor in series), relay coils (with diode protection) and some motors (with diode protection). The output voltage does not quite reach 0V and $+V_s$, especially if a large current is flowing[10]. Fig. 2.6 below shows how output of a 555 timer can source or sink current from a device.

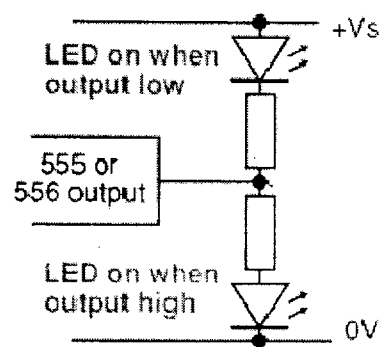

Fig. 2.6. 555 sinking and sourcing current

2.6. REVIEW ON RELAYS

It is often desirable or essential to isolate one circuit electrically from another, while still allowing the first circuit to control the second. For example, if you want to control a high-

voltage circuit from your computer, you would probably not want to connect it directly to a low-voltage port on the back of your computer in case something went wrong and the mains electricity ended up destroying the expensive parts inside your computer.

One simple method of providing electrical isolation between two circuits is to place a relay between them, as shown in the circuit diagram of fig.2.7. A relay consists of a coil which may be energised by the low-voltage circuit and one or more sets of switch contacts which may be connected to the high-voltage circuit.

2.6.1. How Relays Work

In figure 2.7a the relay is off. The metal arm is at its rest position and so there is contact between the Normally Closed (N.C.) switch contact and the 'common' switch contact.

If a current is passed through the coil, the resulting magnetic field attracts the metal arm and there is now contact between the Normally Open (N.O.) switch contact and the common switch contact, as shown in figure 2.7b.

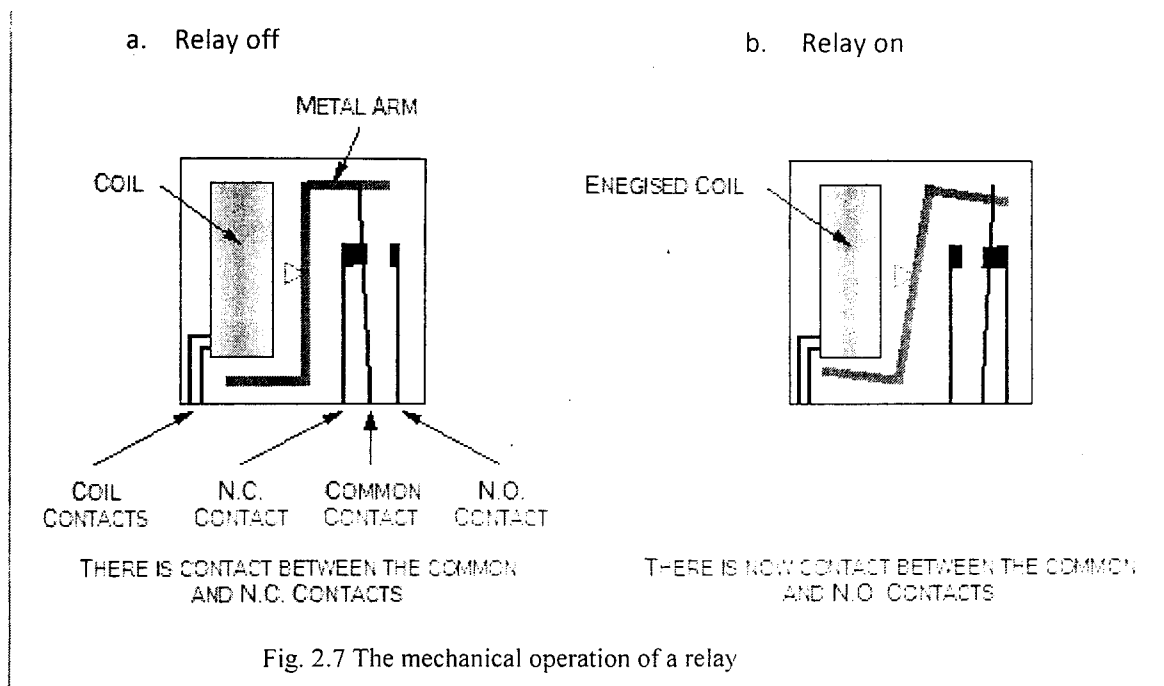

Advantages of Relays

- The complete electrical isolation improves safety by ensuring that high voltages and currents cannot appear where they should not be.
- Relays come in all shapes and sizes for different applications and they have various switch contact configurations. Double Pole Double Throw (DPDT) relays are common and even 4-pole types are available. You can therefore control several circuits with one relay or use one relay to control the direction of a motor.
- It is easy to tell when a relay is operating - you can hear a click as the relay switches on and off and you can sometimes see the contacts moving.[8]

CHAPTER THREE

DESIGN AND CONSTRUCTION

The design and implementation/construction of a single phase automatic change over switch is based on modular approach where each block of the block diagram is taken and examined Vis a viz its circuit diagram.

3.1 AUTO OVER VOLTAGE PROTECTION

This segment of the circuit protects the house from over voltage as well as the power supply unit from the mains utility supply. It is composed of a triac and an AC 220v Relay. The relay disengages the house from the mains utility whenever the voltage reaches 250v

3.1.1 Triac

The TRIAC is a three-terminal device similar in construction and operation to the SCR. The TRIAC controls and conducts current flow during both alternations of an ac cycle, instead of only one. The TRIAC lead is on the same side as the gate is “main terminal 1”.

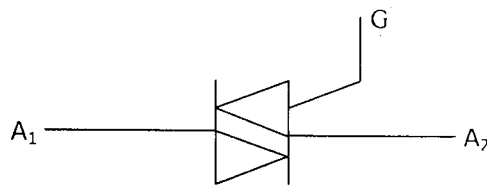

Fig. 3.1. triac symbol

Maximum forward current = 10A

Break over voltage = 200v AC

Part BTA - 10 - 200B

Case Style TO - 220

3.1.2 220v Ac Relay

This protects the house and the engine switch transformer from over voltage as it will be energized and consequently disengage the house from mains utility supply in the event of over voltage.

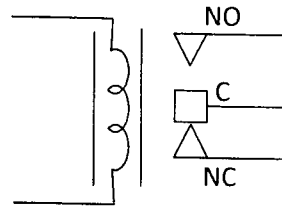

Fig.3.2 220v AC relay as the over voltage relay

Selection of AC relay was based on its ability to handle AC.

Operating voltage = 220v

coil Resistance = 14k (measured)

$$\begin{aligned} \text{operating current} &= \frac{220v}{12k} \\ &= 15.17mA \end{aligned}$$

Fig.3.3a and b below shows the complete circuit diagram of the overvoltage protection unit.

Fig.3.3 a. shows the behaviour of the AC relay under normal voltage while fig3.3b shows

how the relay is being activated under an overvoltage condition.

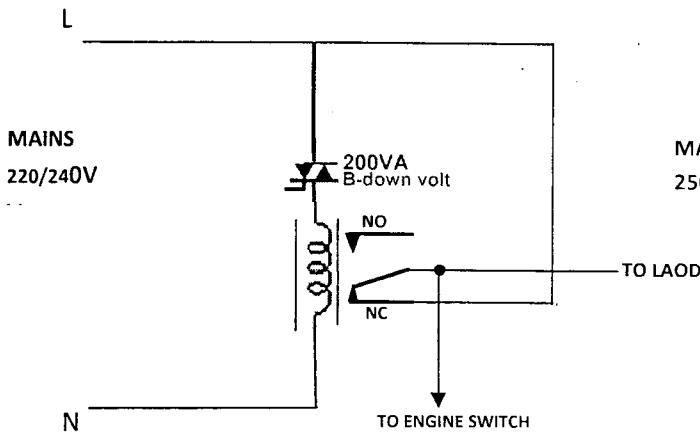

Fig.3.3a Normal Voltage Condition

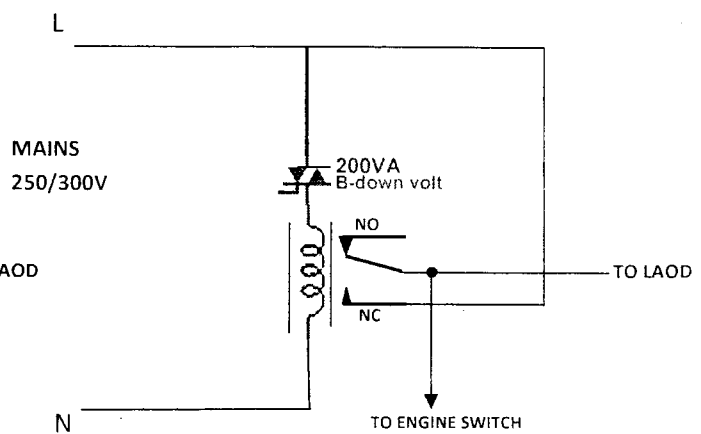

Fig.3.3b Over voltage condition

The ac relay operating voltage is 220v maximum but can be operated by voltages around 80v

At 220v input the triac (having 200v break over voltage) still outputs 39v (as measured with the meter) with an extra 19v. This means that at even at 200v input to the triac will still output 19v.

It then means that if 250v is to be chosen as over voltage the triac output will be as follows:

$$250 - 200 + 19 = 69v \text{ close enough to operate the overvoltage relay.}$$

3.2 ENGINE SWITCH

The engine switch is made up of 6v DC Relay. Its function is to stop the generator just in case it was running before the return of the mains utility supply. It takes in as its input the rectified and the smoothed 6v DC from the mains supply. Its normally open contact is connected to the ignition coil of the generator. Fig 3.4a and fig.3.4b shows the 6v DC relay and the complete circuit diagram of the engine switch.

Operating voltage = 6v

Current = 16mA

$$\text{Coil Resistance} = \frac{6v}{0.016} = 375 \text{ ohms}$$

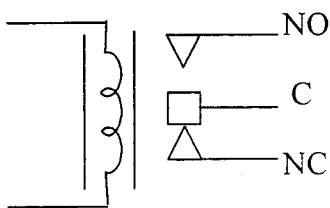

Fig.3.4a 6v DC Relay as Engine Switch Relay

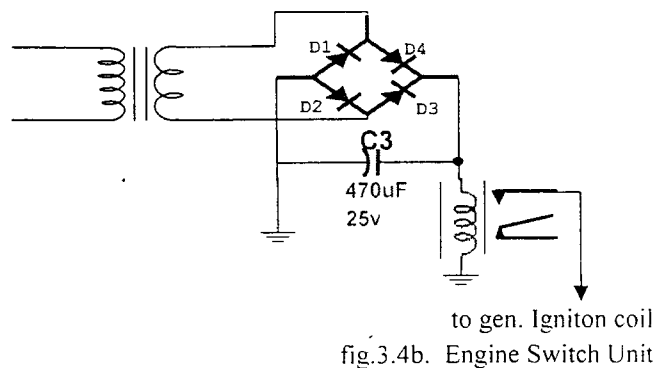

fig.3.4b. Engine Switch Unit

3.3 AUTO CHANGE-OVER SWITCH

The change-over switch is a combination of three number of 12v d.c relays connected in parallel. The three relays represent live, neutral and earth of mains, load and generator respectively. Fig.3.5 shows the parallel connection of the changeover relays.

The parameters of the change over relays are as follows:

Coil Detail	= 12v DC
Normally Close Contact (NC)	= 20A 240v AC/28v DC
Normally Open Contact (NC)	= 30A 240v AC/28v DC
Operating Current	= 30mA

$$\text{coil resistance } R = \frac{12v}{30mA} = 400\Omega$$

$$\text{Therefore power ratings of each } P = 12 \times 30 = 0.36kW$$

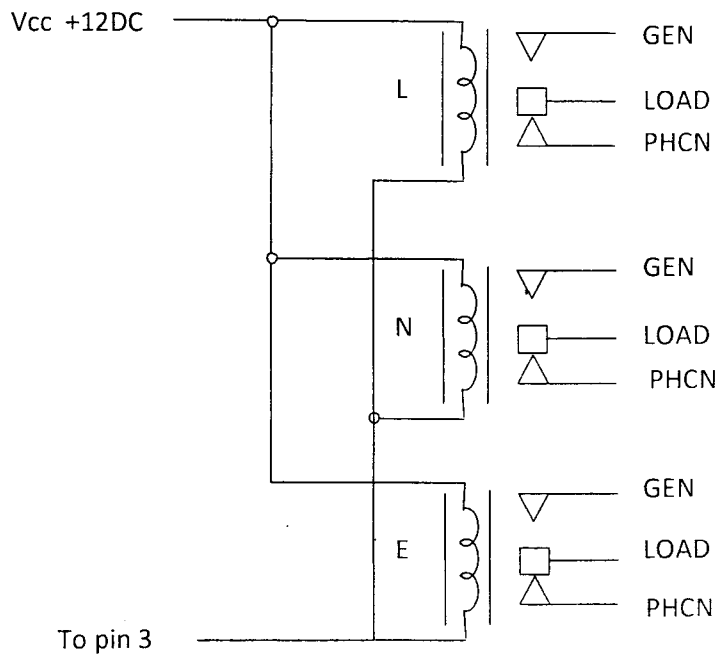

Fig.3.5. Changeover relays in parallel

3.4 DELAY CIRCUIT

The delay circuit is incorporated in order to optimize the generator performance. The delay is made up of 555 timer circuit configured in the astable mode.

3.4.1 555 Timer

The 555 timer IC is made of a combination of linear comparators and digital flip-flops. The entire circuit is usually housed in an 8 pin package [11]. The circuit symbol of 555 timers IC is shown in fig.3.6 below [10].

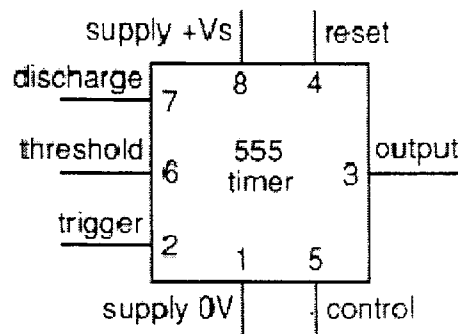

Fig. 3.6 555 Time Circuit Symbol

The 555 timer IC can be configured in different modes namely monostable, astable and bistable mode

3.4.2 555 timer selection

Astable circuit

This produces a continuous train of pulses at any frequency required. The name “astable” means “never stable” – the output of the circuit never stays in any of two states.

3.4.3 Sinking and Sourcing

In fig.3.7a, a device is shown connected between the Output pin 3 and 0V. When the Output goes high, current will flow through the device and switch it on. This is called 'sourcing'

current because the current is sourced from the 555 and flows through the device to 0V.

In fig.3.7b, the device is shown connected between the Output pin 3 and V_s . When the Output goes low, current will flow through the device and switch it on. This is called 'sinking' current because the current is sourced from V_s and flows through the device and the 555 to 0V.

In fig.3.7c, sourcing and sinking are used together so that two devices can be alternately switched on and off.

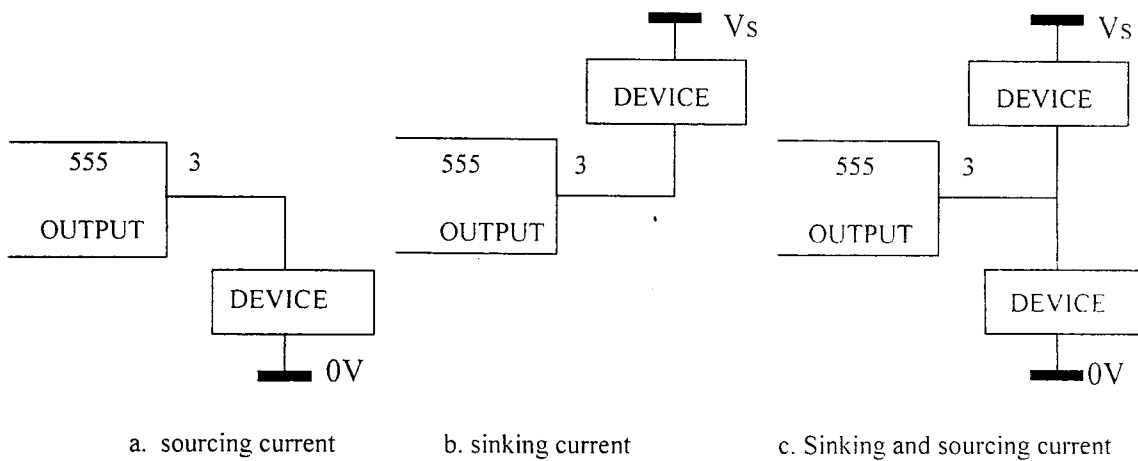

Fig.3.7 Sinking and sourcing current

The device(s) could be anything that can be switched on and off, such as LEDs, lamps, relays, motors or electromagnets [8].

The connection in fig.3.7b was selected for this circuit design in order to achieve the necessary delay. However since this is an astable mode configuration which means that the output of the circuit never stays in one state, the pin 2 of the 555 timer was not connected in order to prevent it from sensing when the voltage across the capacitor goes below $1/3V_s$ during the capacitor discharge. By so doing the trigger input will not be set high and the load remains connected to the generator as changeover relays continues to receive power from

the V_{cc} (Vs). Thus a monostable mode of operation is achieved using an astable configuration. Monostable configuration is not used in this circuit because monostable requires manual triggering in addition to the supply voltage.

The 400 series IN4001 diode is a freewheeling diode. When a relay is de-energised it normally produces back-emf that would normally damage the 555 timer. The diode shorts out this back-emf so that no damage occurs [8].

3.4.4. Delay Time Calculation

for astable configuration $T_{high} = 0.7 (R_1 + R_2) C$

$R_1 = 100k\Omega$ $R_2 = 200 \Omega$ and $C = 100\mu F = 0.0001F$

$T_{high} = 0.7 \times (100 \times 1000 + 200) \times 0.0001 = 7.0 \text{ secs}$

But the output-high time of the 555 timer is the load-low time of the load and consequently the delay time i.e. $T_{output(high)} = T_{load(low)} = T_{delay} = 7.0 \text{ secs}$

Therefore delay time is 7.0 secs

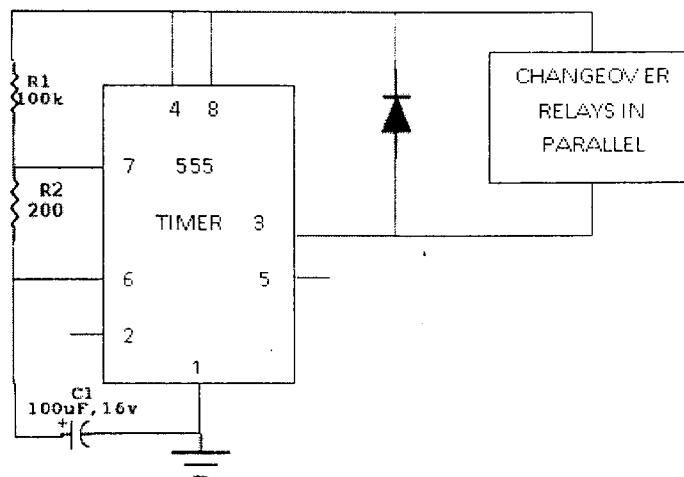

Fig.3.8. Circuit diagram of time delay circuit

CHAPTER FOUR

TEST, RESULT AND DISCUSSION

4.1. TEST

The behaviour of the circuit was tested on the bread board before final realization on the vero board. At every point continuity test was carried out to make sure that there was no open circuit. The next step was the transferring of the circuit onto the vero board which requires soldering of the components. Noise that was noticed on the breadboard connection was minimal on the vero board.

This circuit is interfaced with the cut-out fuse, overvoltage protection unit (ac relay), meter and the load. Not all these units were available during the test. The meter and the cut-out fuse were missing while testing. So therefore the test was carried out with the cut-out fuse and the meter being respectively shorted (i.e. a single stretch of cable stand in their respective places).

The test was carried out with two power cable, one representing PHCN supply and the other one representing the Generator supply. A bulb was used as the load. When the PHCN cable was plugged into an AC socket the bulb light up instantly (since the voltage was not over voltage there was no disengagement of the load from the power by the AC protection relay). It was assumed that before plugging the PHCN cable the generator was running which went off automatically with the plugging of the PHCN cable. Generator was not actually available though.

The PHCN was then unplugged to signify power failure. Generator cable was then plugged into the AC socket. A delay of about 10 seconds was observed before the bulb light up signifying the needed time for the generator to get up to speed before placing the load on it.

The light remained on for as long as the cable was not unplugged. This is a confirmation of the monostable mode of operation using an astable configuration of the multivibrator.

N.B.

1. If the need arise to start the Generator while the PHCN power is available the engine switch cable must be disengaged or disable otherwise the Generator cannot be started.
2. The engine switch should be connected to the spark plug head of the generator since it could be difficult to accessing the ignition coil.

4.2. RESULTS

There were variations or deviations between the actual times it took the test bulb (load) to light up and the calculated theoretical delay time of 7 sec. Table 4.1. shows the result

Table 4.1. Measured Time and the calculated time delay

S/NO	Measured Time(secs)	Calculated Time (secs)	Deviations (secs)
1	12.0	7.0	5.0
2	12.7	7.0	5.7
3	11.5	7.0	5.5
4	10.9	7.0	3.9
5	10.7	7.0	3.7
6	11.7	7.0	4.7
7	12.3	7.0	5.3
8	10.5	7.0	3.5
9	9.9	7.0	2.9
10	10.3	7.0	3.3

4.3. PROBLEMS ENCOUNTERED

Problems encountered as they affect the results are listed below:

1. Inconsistent delay time
2. Click sounds were produced by the changeover relays and the engine switch relay any time they are powered
3. At 220v AC supply the triac outputs about 39v as against the expected 20v.
4. Humming sound was produced by the 220V AC relay when ever the PHCN supply is available
5. It was impossible to start the generator whenever the engine switch is connected

4.4 DISCUSSION OF RESULTS

- The inconsistency in delay time was due to imperfect behaviour of the electrolytic capacitor.
- The sounds produced by the relays were due to movement of the C-terminal of the relay to the NO-terminal when it receives power. The sound however tolerable.
- The extra 19v triac extra output could be from the manufacturers design
- Humming sound of the AC relay is an indication that the struggling to operate as the input it receives approaches its minimum operating voltage.

CHAPTER FIVE

CONCLUSION AND RECOMMENDATIONS

5.1 CONCLUSION

From the aims and objectives of this project to the construction and results obtained it can be concluded that the design and construction of single phase automatic change over switch for domestic purpose can not be overemphasized.

Successful changeover entails total elimination of the risk involved in the manual changeover process – that is achieved.

Economy being one of the projects objectives was achieved by automatic shut down of the generator by the return of mains supply i.e. no more waste of fuel due to un-noticed return of mains. Since it was designed for domestic purpose. automatic starting was not considered in this design. Domestically will prefer to start the generator at their own convenience.

Generator delay which is what most students that have designed similar project have fail to take cognizance of will certainly prolong the generator's life span.

The over-voltage unit serves in case the cut-out fuse fails.

One of the achievements of this project design is its relatively low cost of construction as compared to previous similar construction projects. It is of course a tradition in the field of engineering to consistently search for ways of making difficult tasks simple and reducing costs of production so that products could be affordable to users at low cost.

5.2 RECOMMENDATIONS

For future improvements and modification by an interested student the following recommendations could be helpful.

1. Three phase application of the project with automatic fusing system can be incorporated
2. The 555 delay timer could be replaced with a microcontroller to achieve consistency in the delay
3. Higher current capacity relay could be employed.
4. For application in commercial settings, industries, and hospitals where total power failure could spell doom, the generator timer circuit could be expunged and an automatic generator starting circuit incorporated.

REFERENCES

- [1] <http://www.wikipedia.com/transfer> switch 22/5/2009 .
- [2] E. E. Okafor "Development Crisis of Power Supply and Implications for Industrial Sector in Nigeria" Stud Tribes Triabals, 6(2): 83-89 (2008) Department of sociology, university of Ibadan, Nigeria
- [3] A. Akaeze, "News Watch Magazine", Sunday 8 March 2009.
- [4] S. P. Parker. McGraw-Hill Dictionary of Science and Science Technical Term" 2nd Edition, McGraw-Hill Book, New York pp128.
- [5] V. R. Tony, "555 Timer Tutorial", pp1
- [6] S. Paul, "Practical Electronics for Inverters", pp589
- [7] J. G. Watter, "IC Timer book, second Edition", pp91
- [8] <http://www.electronicmeccano.com/relays> 22/5/2009
- [9] <http://www.wikipedia.com/555timerIC> 22/5/2009
- [10] J. Hewes 2009, The Electronics club, <http://kpsec/freeuk.com/555> and 556 timer 25/6/2009
- [11] R. L. Boylestad and L. Nashelsky, Electronic Devices and Circuit Theory 8th Edition

APPENDIX

Single Phase Change-over Switch Circuit Diagram

