

TITLE PAGE

**REMOTE SENSING APPLICATION IN LARGE-SCALE SURVEYING
(USING GLOBAL POSITIONING SYSTEM, GPS)**

BY

**ALAMU, ELIJAH OLUSANJO (M.Tech/SSSE/0057/96)
B. TECH (LAND SURVEYING),
FEDERAL UNIVERSITY OF TECHNOLOGY
MINNA, 1995.**

**A THESIS SUBMITTED IN PARTIAL FULFILMENT OF THE REQUIREMENT FOR
THE DEGREE MASTER OF TECHNOLOGY (REMOTE SENSING APPLICATION)
FEDERAL UNIVERSITY OF TECHNOLOGY MINNA, NIGERIA.**

MAY, 2000.

CERTIFICATION

This dissertation entitled 'Remote Sensing Application in large-scale Surveying - Using Global Positioning System, GPS' by Alamu Elijah Olusanjo meets the regulation governing the award of degree of Master of Technology (M.Tech) of Federal University of Technology, Minna and is approved for its contribution to knowledge and literary presentation.

.....
Prof. D. O. Adefolalu
Supervisor

.....
Date

.....
Dr. Umoh T. Umoh
Chief Examiner/HOD

.....
14-12-2000
Date

.....
Prof. J. O. Adeniyi
Dean Post Graduate School

.....
9/2/2001
Date

.....
Prof. E. J. Usoro
External Examiner

.....
14-11-2000
Date

DECLARATION PAGE

**Remote Sensing Application in Large Scale Surveying
(Using Global Positioning System, GPS)
Alamu, E. O. M. Tech. (Remote Sensing Application), 2000.**

I hereby declare that this project work is a record of my handwork. It has neither been presented nor accepted in any previous application for a higher degree.

ALAMU, E. O.

DATE

DEDICATION

This work is dedicated to the Glory of the Almighty God, who was, who is and who forever shall be. It was impossible but He made it possible, Glory be to his name.

Also, it is dedicated to the memory of my old man, Pa Ezekiel A. Ishola, who slept on the 5th of January, year 2000.

Sleep on till we meet to part no more!

ACKNOWLEDGEMENT

I wish to express my gratitude to all who contributed to the completion of this work. First, I thank God almighty who reigns supreme and who enabled me complete this work after all hopes seemed lost.

I like to acknowledge the contributions of my supervisor, Professor Adefolalu – his not getting tired of my seeming unseriousness, his modification of the title and tireless comments on the whole work. I appreciate the efforts of Dr. Appollonia in getting me started and encouraging me to be more serious. I thank the former Head of Geography Department Dr. Nsofor for his fatherly advice and interest in seeing the completion of the programme. Also the present Head of Department, Dr. Umoh T. Umoh for his assistance and help. I thank all staff members in the (Geography) department for their individual and combined efforts and assistance. Miss T. Aborisade is specially acknowledged for her assistance. May God reward you greatly.

Acknowledgement is due to Surveyor S.O. Akanbi and Surveyor Bayo Adewolu who provided the opportunities for use of the GPS equipment, projects and other materials that were used for the report.

Mr. John Manukaji, thanks for all that genuine concern, effort and encouragement to ensure completion of this programme. I appreciate it all, thanks. Mr. Taliat, Mr. Kolawole, Nath, Y. Zakari, and other friends/colleagues, who cannot be singularly mentioned for space, I say thank you and God Bless.

To my family members I say thanks, May God strengthen the cord that binds us together.

Finally to you Bose, thanks for the patience, encouragement, support and understanding. May the good Lord preserve us. Thanks to all and God Bless.

ABSTRACT

The coming of the GPS has been greeted with so much invincibility that the surveying profession looks unnecessary. What with the high accuracy guaranteed by this technique. Much myth is associated with what can be done with the GPS that it needs closer study.

Large scale surveying on the other hand has been a difficult area of venture for most Remote Sensing techniques. The adoption of GPS to give a detailed survey at any scale is therefore a welcomed development.

This project serves to illustrate possible ways of applying the GPS for large-scale surveying. In particular, two approaches are illustrated.

- (1) Obtaining co-ordinates of points, which could define a plot, purely by GPS, technique.
- (2) Combining the GPS with other surveying methods especially where controls are not existing. The GPS is used to set up these controls - to the highest level of accuracy and the traversing method used to complete the survey. This is most useful where the present cost of using the GPS solely could be unbearable.

The work therefore serves to buttress the fact that GPS is very much applicable in our area. Both results confirm acceptability of GPS observations and the need for all users to embrace it as quickly as possible. Some limitations or constraints in the use of GPS are highlighted.

LIST OF FIGURES

Fig 2.1 Point Positioning	9
Fig 2.2 Differential Positioning with GPS.....	9
Fig 2.3 GPS Signal Operation/Interaction	10
Fig 2.4 GPS Segments.....	12
Fig 2.5 Procedure for obtaining ground control Points with aid of GPS.....	14
Fig 2.6 Key parts of the GPS Receiver.....	17a
Fig 2.7 GPS controller - Definable point identifiers.....	17b
Fig 2.8 GPS connection of units.....	22
Fig 2.9 Error effects on signals.....	24
Fig 2.10 Typical equipment sets for real-time GPS surveying.....	28

LIST OF TABLES

Table 3.1 Summary of Mean observed angles and distances:.....	31
Table 4.1 GPS Results of points in Longitude and Latitude):.....	43
Table 4.2 GPS Results of points in UTM (Oyo):	43
Table 4.2b GPS Results of points in NTM (Oyo):	44
Table 4.3 GPS Results in (UTM) of control points in Dakogi (Mokwa):	44
Table 4.4 Abstracts of Results in NTM:	45
Table 4.5 Traversing Results (Oyo) in NTM:	46
Table 4.6 GPS Result (Mokwa) in UTM:	46
Table 4.7 List of Co-ordinates demarcating Farmland in Gbakogi (Mokwa):.....	47

TABLE OF CONTENTS

Title page:	i
Approval page:.....	ii
Declaration page:.....	iii
Dedication:.....	iv
Acknowledgement:.....	v
Abstract	vi
List of Tables:.....	vii
List of Figures:.....	viii
 CHAPTER ONE (INTRODUCTION)	
1.0 Introduction:.....	1
1.1 Problem Statement:.....	3
1.2 Aim and Objectives:.....	3
1.3 Hypothesis:.....	4
1.4 Need for the project:.....	4
 CHAPTER TWO (LITERATURE REVIEW)	
2.0 Introduction:.....	5
2.1 Surveying:.....	5
2.2 GPS Invention:.....	7
2.3 Principles of GPS:.....	10
2.4 GPS Segments (Composition) :.....	11
2.5 GPS use:.....	13
2.6 Key parts of the GPS Receiver:	16
2.7 GPS Processing, Accuracy and Advantages:	23

2.8 Applications:	26
2.9 Summary of Facts about GPS:.....	27
CHAPTER THREE (DATA ACQUISITION)	
3.0 Data Capture:	29
3.1 Traversing - Oyo:	29
3.2 Traversing - Dakogi:	31
3.3 GPS Observation - Oyo:	34
3.4 GPS Observation- Dakogi:	37
3.5 Some Practical Hints in GPS Survey:	38
CHAPTER FOUR (COMPUTATION/ANALYSIS)	
4.0 Computation / Analysis:	39
4.1 GPS Computations:	39
4.2 Traverse Computations:	47
4.3 Abstracts of Results:.....	48
4.4 Comparison and Analysis of Results:	51
CHAPTER FIVE (CONCLUSIONS)	
5.1 Findings:.....	55
5.2 Summary:.....	56
5.3 Conclusions:.....	57
5.4 Recommendation(s):	58
5.5 References:	60

CHAPTER ONE

1.0 INTRODUCTION

Surveying involves reducing the earth or any part thereof unto a plane piece of paper. It involves acquiring data through measurements, (of Angles and Distances), refining the data through computations and the final plotting of the result. Data collected is usually processed to obtain co-ordinates on a reference surface and then details are plotted relative to these co-ordinated points.

The History of surveying dates back to creation of the Universe by God (Gen. 1). The need to demarcate, divide, plan, develop and document Land has always been necessitated, calling for surveying.

To survey a piece of land by traditional techniques, four or five basic steps are required:

- Reconnaissance (Recce)
- Observation
- Computation
- Plotting
- Report.

Each of these steps are complete operation in themselves. They could take varying lengths of time, Energy and resources.

The observation stage, which is the data capture stage, could be very tedious, requires several hands to accomplish and most importantly required the pre-availability of controls.

Controls are points of reference. They are points established with prescribed accuracy. They are needed prior to any survey for origin, orientation and control.

They enable any survey to be checked and evaluated, and to be connected to the national frame. Where no previous control exists, the survey carried out is localised i.e. it is on local origin. It must later be connected to a control. This frequently occurs, as controls are not every where yet.

With modern techniques however, the GPS enables the survey to be completed irrespective of controls. If controls are not available within a locality, simply the GPS is used to establish a set, and the survey connected straight to it. Better still, the GPS could be used to carry out the entire survey.

However, the controls established by the GPS must be comparative in accuracy to that established by the conventional methods. If this is not assured, the acceptability of this new work will be in question.

Owing to the ease/convenience with which the GPS operates, it is easy to overlook this important requirement.

The idea of the GPS is not entirely new. Observations to heavenly bodies (sun and stars) had in the past being made to determine longitude and latitudes. The results from such process were favourable. The major problem was that such observation was made in circular units (degrees, minutes and seconds), which could at best be obtained, to one decimal place. Conversion of these circular units to linear value gives an unacceptable result. One second of arc on the earth surface translates to about 30m on the ground. Hence results from astronomical observations could not be used for any form of control establishment. At best it was used to get a 'close value' to the real co-ordinates and used as Local Origin.

The GPS also determines the Longitude and Latitudes of a point, but by observation to some artificial satellite not natural heavenly bodies. It iterates and re-iterates the results so that it can get Longitudes and Latitudes to some Three to Five

(3-5) places of decimals. Thus Centimetre or even Millimetre accuracy are assured depending on the make of equipment.

With its obvious advantages and versatility, the GPS will be preferred. What with its computer link, which ensures that with adequate software, package 'no computation is needed'. The whole process is simply automated even to the plotting. Caution however needs to be exercised in the use of new techniques, GPS inclusive. Therefore, facts have to be sifted from fantasies. This work therefore sets to probing a little into the world of GPS. We need to know where the limits lie. We need to know what cautions to uphold.

1.1 PROBLEM STATEMENT

The GPS has set to revolutionize surveying practice. Is the result from this method, as reliable as the technique is dazzling? Or should there be some restraint? Where does its (GPS) application Start? Where should it end? Of what significance is the contribution of this new technology going to be to the future surveying?

1.2 AIM AND OBJECTIVES

The focus of this work is Global Positioning System (GPS). How it captures data, and the results - how accurate is it? Surveying is a precision profession. Does the GPS meet this quality? To this end we shall:

- Access the relevance of GPS in surveying
- Determine the ideal occasions and situations to use GPS in surveying
- Highlight major constraints (if any) of GPS
- Proffer solutions/modification to the use of GPS in surveying
- Make other recommendations as may be appropriate to the use of GPS in surveying for the future.

1.3 HYPOTHESIS

This Research sets to establish that there is no significant difference in results from GPS surveying and Traditional techniques of surveying, i.e. the accuracy from GPS established points are comparable to those established by classical surveying methods.

$$H_0: B_0 = b_1$$

$$H_1: B_0 \neq b_1$$

If confirmed, then GPS can be used as a substitute for provision of controls for surveying instead of Local Origin presently in use.

1.4 NEED FOR THE RESEARCH.

Surveying is a precision profession, which demands strength, character, academic excellence and Discipline. It demands time, patience, and rigour. It has been one of the oldest professions ever practised. Today with the introduction of GPS, all these seem to make the former way of practice a waste.

Before the GPS, innovations and modifications have taken place in surveying but none of these has been as radical as the GPS. The GPS as it comes today is second only to Computer Technology in modern science. It is therefore imperative to imbibe this new culture with caution. To test and re-test it, to ensure that it is for real. That no loss or degradation will set in to the profession by its adaptation.

It should not just be a mere flashy technology that Bamboozles and dazzles its operator. We want to demonstrate it is for real and applicable, our Location and indeed is already in use.

CHAPTER TWO

2.0 LITERATURE REVIEW

In this chapter, there shall be review of some important elements of the study. The GPS, which has come to revolutionize surveying, will be our intent focus. Knowing where one is, is basic to life. This is the bane of surveying. GPS promises to do this so effortlessly and becomes the next utility. Thus how did GPS come about? How is it used? What are the various types and the various accuracies it can yield etc.

Brief consideration of the classical surveying methods shall be made. Some set backs inherent in them and how the GPS sets to put the traditional methods on the shelves. Attempts at probing questions that should illuminate the GPS will be asked.

It is hoped that our learning on the subject will be highly enhanced after this chapter.

2.1 SURVEYING

Surveying involves co-ordinating points on the earth surface to represent same on a plane surface. Mapping, as this process is often called, is the art and science of representing the earth or parts of its, usually on a flat surface. Such a representation may be to scale and could show physical features such as rivers, Oceans, Roads and other features such as political or cultural boundaries, settlements, buildings etc (Igbokwe 1992).

Surveying is the bedrock of all meaningful planning and development. It tells the total land area available and forms the basis for allocating and planning the use of the land. Surveying serves as an important medium for recording, calculating, displaying,

analysis and understanding the spatial inter-relationship of human activities in an environment. Its main function is to bring things into view. It does this by measurements to determine the position of points, or of marking out points and boundaries on, beneath or above the earth surface. It uses scientific principles to make comparative measurements, always to a required accuracy for purpose of either:

- (a) Measuring what exists to determine location, and translate the data into map or paper plan or Boundary description; or
- (b) Establishing marks to guide the construction of a paper plan, or determine the boundary according to some description or other data.

Effective management of land and its resources, and the effective planning for economic development is hinged on surveying. The planning and execution of economic plans are difficult if not outright impossible without adequate maps and survey plans (Fajemirokun 1983).

Principally carrying out measurements effects surveying. Measurements on the earth surface, usually of angles and distances in accordance with principles of Geometry and Trigonometry. In olden times, there was a major problem of measuring long distances which made most surveying to comprise more of angle measurements and little of distance measurement. Thus we find that TRIANGULATION until the 1960s was the major method of surveying (large scale). With improvements in timing devices, the Electronic Distance Measurement (EDM) made distance measurements simplified and emphasis again shifted to TRAVERSING and TRILATERATION. All these were major innovations in surveying and surveying techniques.

With all the innovations however, the principle and practice of surveying still went along the old traditional procedure of:

- Reconnaissance (Recce)
- Observation
- Computation
- Plotting
- Report.

All these are technical aspects that were reserved (and jealously guarded) exclusively to surveyors, and which could not be handled by 'quacks'.

Observations were made to natural celestial bodies to aid position location on the earth surface, but these were downplayed because of the accuracy obtainable. Along the line Doppler satellite came, which was more formidable and this developed into the GPS today.

In all these mentioned above, points were co-ordinated and used to 'fix' other details within their vicinity. Today the co-ordination of these points is made easier by the advent and introduction of the GPS, which seem set to 'Rubbish' the traditional methods of surveying.

The GPS seems to be the last of developments that will be expected in the surveying world (obviously so in the millennium). In doing its thing, it seems to want to 'wipe - off' those methods before it that gave birth to it.

2.2 GPS INVENTION

2.2.1 INTRODUCTION

GPS means Global Positioning System. It is an extra terrestrial Positioning System (Ezeigbo 1998). It is an equipment employed for the determination of 3 - Dimensional values (co-ordinates) of points using the principle of satellite Geodesy. The concept of the GPS is based on the fact that satellites are put in orbits in space and their Geocentric positions are known accurately at any time. With GPS

receivers, the distance between the receiver and the satellite in the orbit is measured from which the Geocentric co-ordinates of the point is determined (Ezeigbo 1998). Therefore it works on the theory of fixation of a ground station position by **resection*** that position using four or more **Satellites*** as they cruise along their orbits (Akanbi 1998), (See Fig 2.1 and 2.2).

It uses a constellation of 24 artificial satellites launched into space some 20,000km above the earth and orbiting the earth at about 55° to the horizontal. It is based on technology accurate enough to really pinpoint positions anywhere in the world, 24 hours a day (Wright 1990).

GPS uses satellites (also called man-made stars) and computers to determine position anywhere on the earth. "It is a military satellite based Navigation system, developed by the Department of Defence in U.S.A. The system allows for a world wide continuous determination of positions with high accuracy". (Igbokwe J. I.).

2.2.2 DEVELOPMENT

The GPS is an offshoot of Navigation Science. It was developed by the U.S Department of Defence (DOD) to simplify accurate Navigation (JOHNSON, 1998). The idea was started by the launching of the 1st man made satellite - the USSR Sputnik in 1958, and the attempt to keep track of the position of the satellite from positions on the earth. It was discovered in the U.S.A. that if the orbit of the satellite was accurately known, the position of a receiver on the earth could be determined using the satellite position. This led to the development of the Transit System, and in fact to all of the satellite Navigation and Surveying systems available today including the GPS (WRIGHT, 1998).

***emphasis mine**

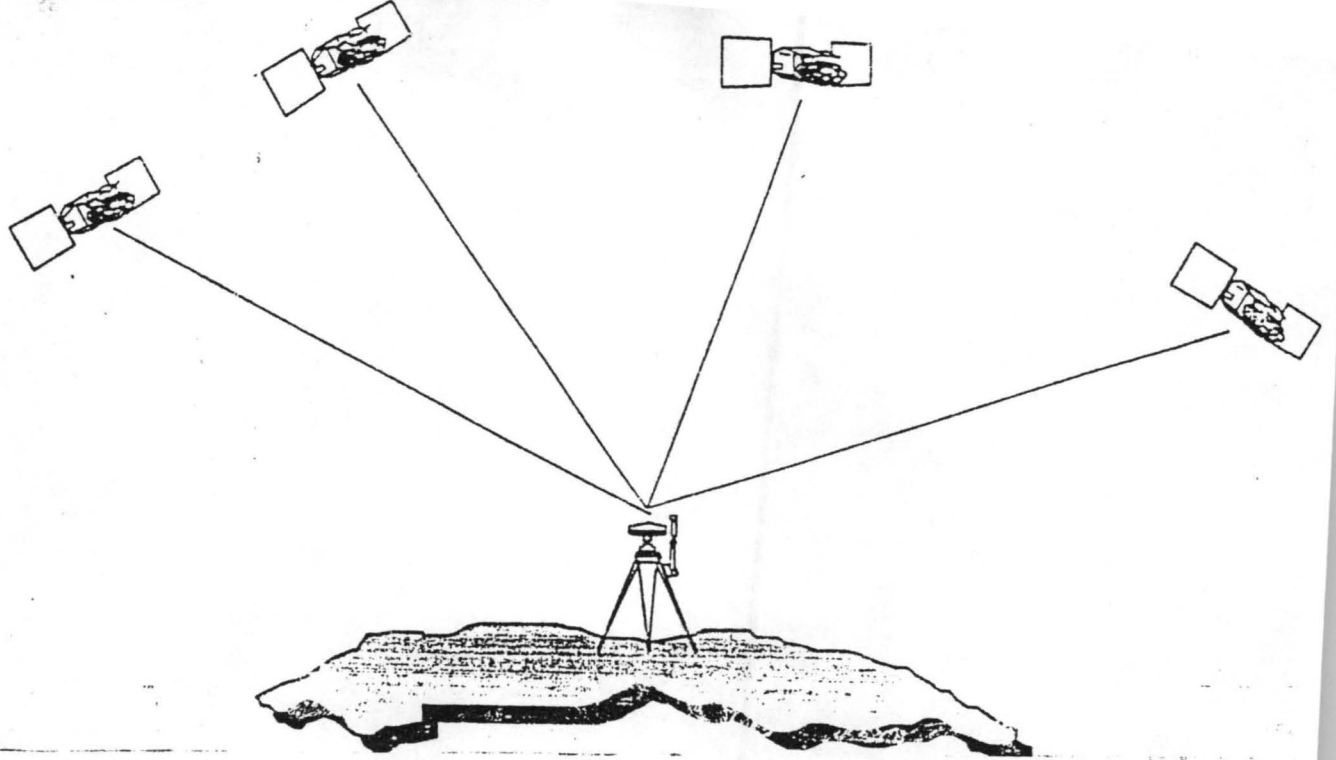
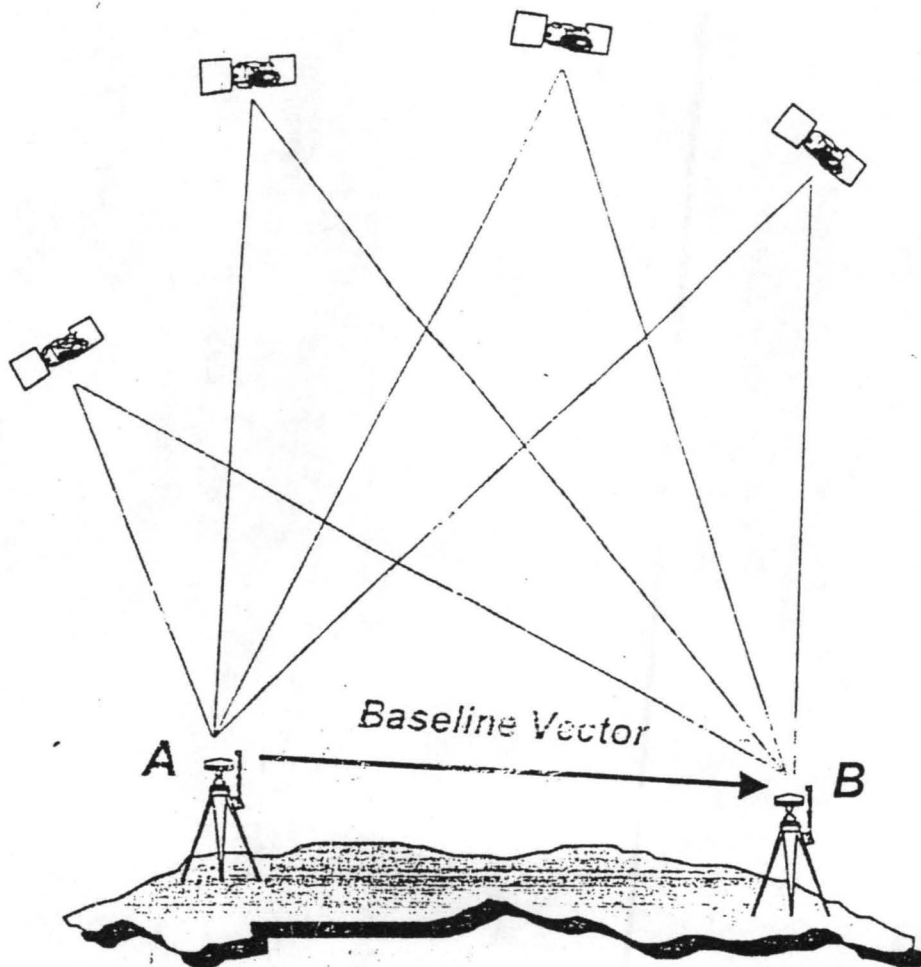

Fig 2.1 Point Positioning



Improvements have been made over the years. A prototype satellite was launched in 1961 and the system was operational in 1964. At the onset, it was purely for military use only, but from about 1967 it was made available commercially. The 1st attempts gave accuracy of a hundred meters but was rapidly improved (Ajibola 1998). Today's results of centimetre and even millimetres accuracy are attainable (Leica, 1996). Before reaching this level, there had been many innovations including the NAVSTAR Global Positioning System in 1973 which is now formally and commonly known as GPS. Many different manufacturers of various versions and types of equipment are now available including Leica and Sokkia among others.

2.3 PRINCIPLES OF GPS

The principle behind GPS is a combination of some vital surveying techniques, which have become enhanced with modern devices. As mentioned earlier, the GPS is a 'glorified' Resection exercise combining effectively with EDM principle. "The basic principle of GPS measurement is based on the equation $\text{Distance} = \text{velocity} \times \text{Time}$ " (Okoronkwo 1998).

Basically, the position of the receiver is determined by measuring its distance from several satellites at the same time. If the positions of the satellites were known exactly, then by measuring distance from three of them it would be possible to determine a position for the receiver. $\text{Distance} = \text{Velocity} \times \text{Time}$.

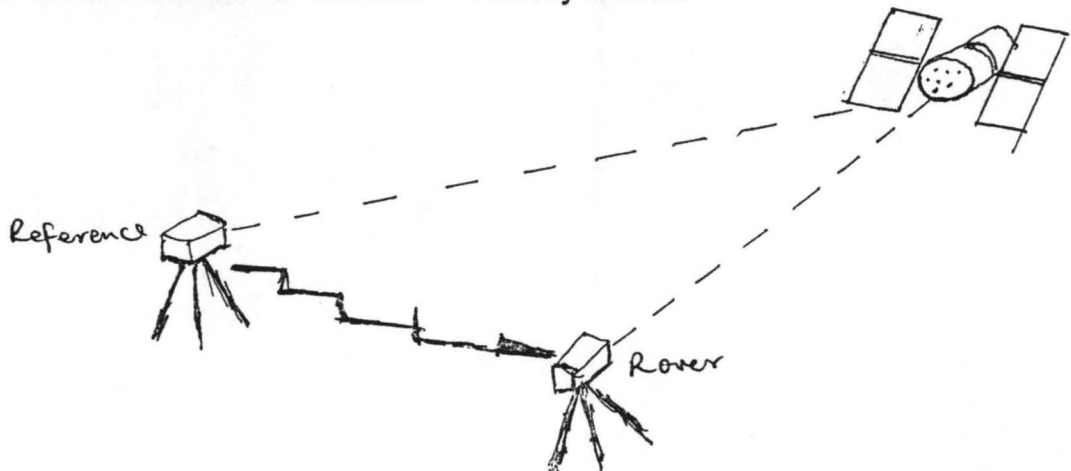

Fig 2.3 GPS Signal operation/interaction.

In practice, two points are chosen at the same time, one 'Reference' the other a 'Rover', each tracking the satellites. Also because of time synchronisation problem there are four unknowns necessitating at least four measurements being required i.e. distance from four satellites to the receiver are required for a definite fix (Wright, 1990).

GPS is simply based on the equation $\text{Distance} = \text{Velocity} \times \text{Time}$. To measure the distance between the receiver and each satellite the receiver has to receive a message from each satellite. (How this is done will be discussed latter). Also, as in astronomy, the altitude to the satellites must not be less than 15o. These go a long way to show that GPS is an off shoot of other surveying techniques. Modern timing accuracy to one nanosecond (0.000,000,001) aids the GPS. It works by timing how long it takes a radio signal to reach us from a satellite and then calculates the distance from the time. GPS is a child of the electronic revolution. GPS relies on an advanced form of quartz watch that keeps unbelievable times. Most GPS receivers can measure time with nanosecond accuracy. (Johnson, 1998).

2.4 GPS SEGMENTS (COMPOSITION)

There are 3 vital organs that make GPS possible. Each performs specified duties in the process of obtaining information from GPS. These are:

- (1) The Control segments
- (2) The Space segments and
- (3) The User segment.

These organs are related as shown in the figure below:

THE THREE GPS SEGMENTS

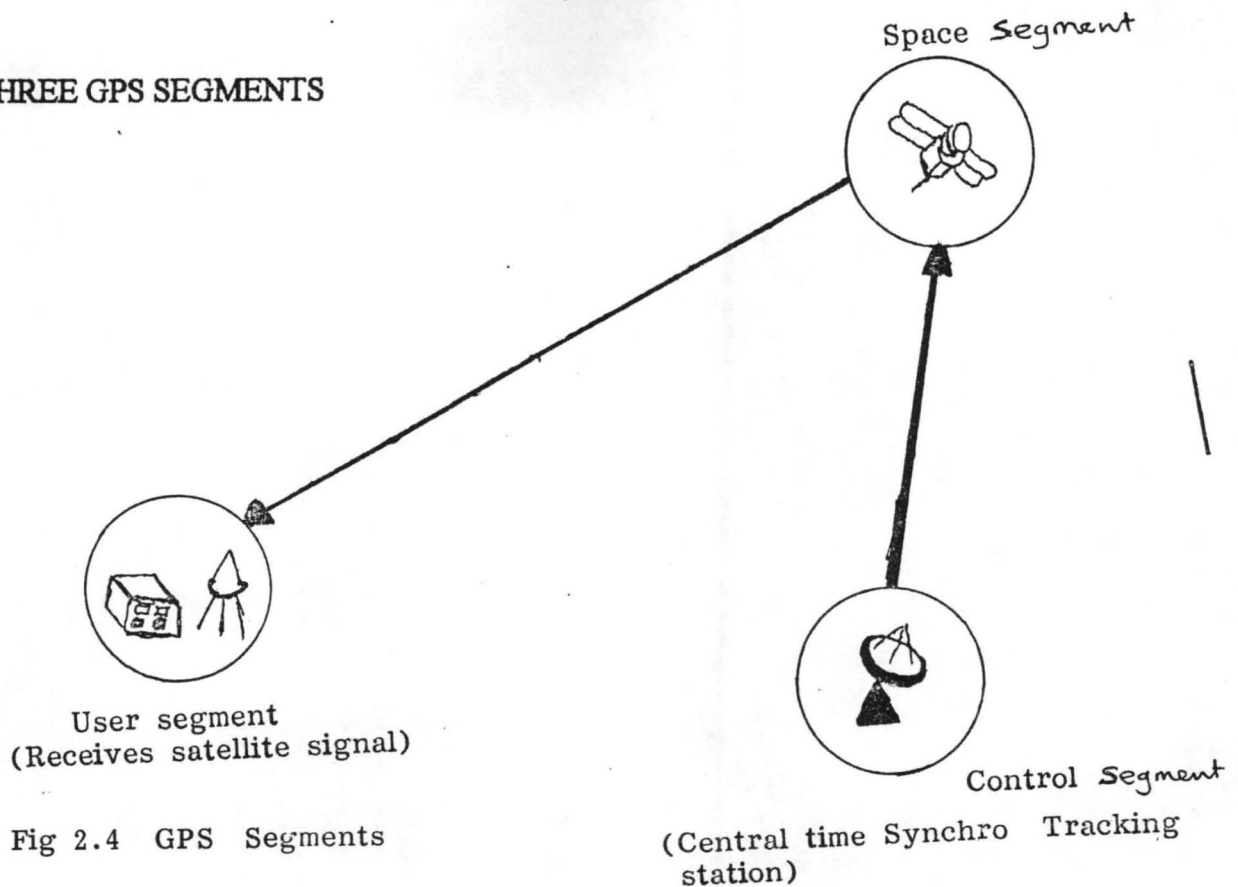

Fig 2.4 GPS Segments

2.4.1 CONTROL SEGMENT

This consists of the master control station, five monitoring stations and world-wide distributed Antennas for time and system control as well as orbit observation and forecasting. (Igbokwe ,1996). The master control is located at Colorado spring where all data is collated and computed to provide the satellite ephemeris, the satellite clock and satellite Navigation message transmitted by each satellite (Ajibola ,1998).

The monitor stations at Hawaii, Colorado springs, Ascension Island, Kwajeleih island and Diego Garcia trap satellite data and transmit same to the master control station. Navigation messages determined at master control station are transmitted to upload stations where messages control commands are injected to each satellite.

2.4.2 SPACE SEGMENT

Consists of 21 satellites and 3 active reserve satellites. The GPS - satellites orbit the earth in 6 orbital planes at a height of 20,000km. The orbits contain at any

given time 4 GPS - satellites and are located at an inclination of 55° against the equator. This allows permanent coverage of the earth surface with at least 4 satellites at any given time. (Igbokwe, 1996). Each satellite is equipped with atomic clocks for accurate timing which is key to the measurement.

2.4.3 USER SEGMENT

This consists of the different receivers for different purposes, and is the most visible part of the System. It consists of the user on earth who can either be static or in motion. Positions can be fixed using a simple hand carried mobile receiver. The receiver receives signal from at least 3 satellites (fig. 2.1).

For each signal, the position of the satellite is determined using phase measurements and the distance between the satellite and the receiver. These data are used to compute the horizontal position of the receiver. Horizontal and vertical position can be obtained through comparison of signals from at least 4 or more satellites (Igbokwe, 1996).

2.5 GPS USE

2.5 GPS USE

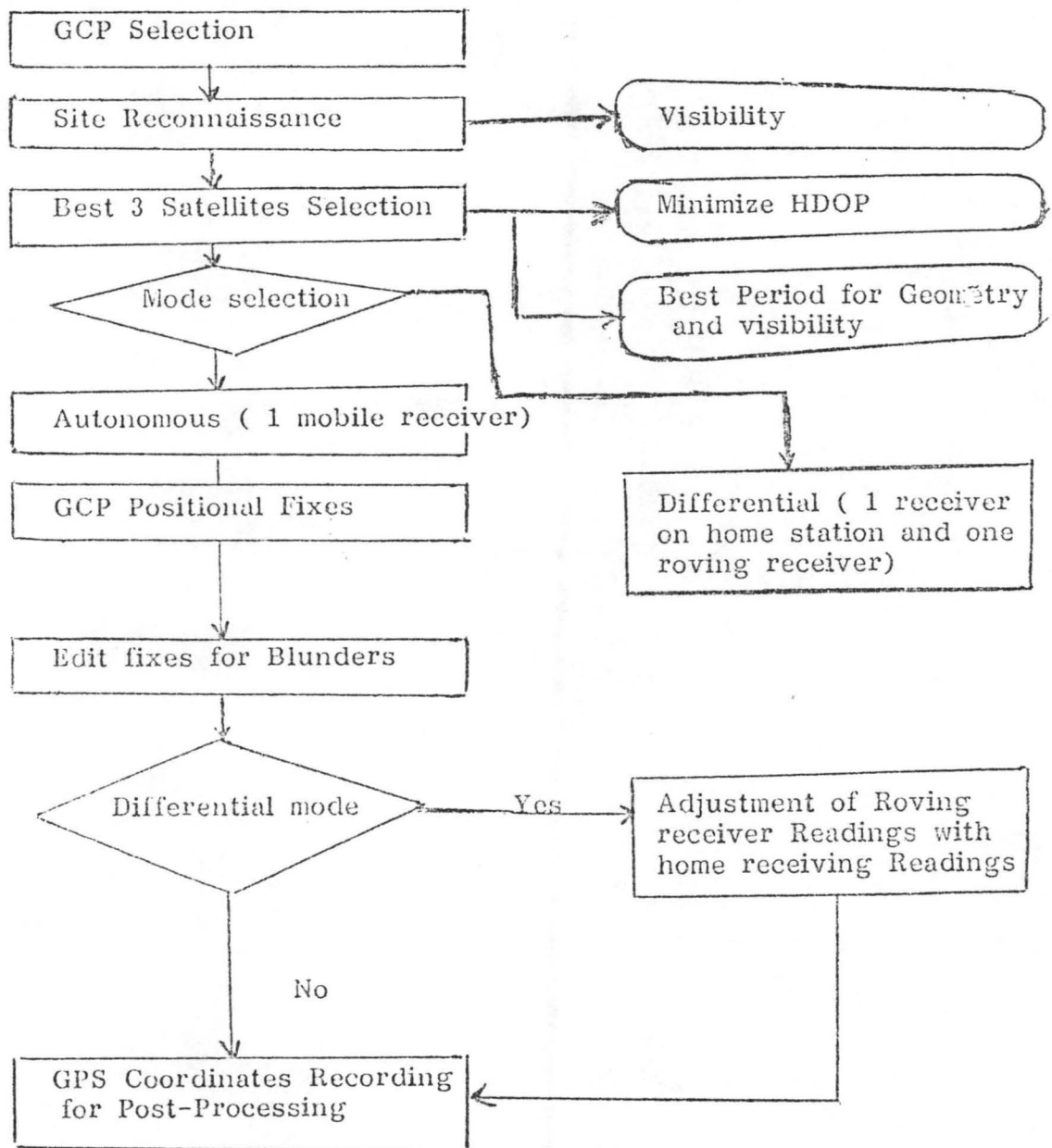

FIG 2.5 Procedure for obtaining ground control points with aid of GPS

(SOURCE: Igbokwe J.I., 1996)

2.5.1 GPS Observation

The GPS can be used for observation in two ways - Absolute mode or Differential mode.

ABSOLUTE MODE

Here only one set of equipment is used over one station at a time. Signals are received from this point and used for processing its co-ordinates. This method is however comparatively inaccurate. It is thus not always encouraged.

DIFFERENTIAL MODE

In this method, two sets of identical equipment are used simultaneously. One, a reference or master, usually set up on the control and left permanent there, and the other a rover or servant, which moves about. The GPS is better used in this mode as the accuracy is much improved. If there are several stations to be observed at, the Reference is positioned on one point while the Rover is placed on the stations in turns. The two sets must be in operation at the same time. If the points are far apart, communication equipment may be needed for synchronising to forestall run-down of the Batteries.

2.5.3 GPS OPERATION TYPE

The technique to use is dependant on the job at hand., We have several ways to operate the GPS Including:

(1) Static mode:

This is ideal over long distances say 5-10km and above. It is suitable method for use in control establishment where very high accuracy is expected. The timing at the stations could be long, say 30 or more minutes to ensure that all ambiguities are resolved. With all precautions taken and good transformation parameters an accuracy of 1/2,000,000 can be expected (Omilabu, 1999).

(2) Rapid static mode:

A subset of static mode. Used for distances shorter than 2km. Less time required say 15-30 minutes.

(3) Stop and Go Mode:

This is used for small areas and for less accuracy job e.g. engineering survey, detailing etc.

(4) Kinematic Survey mode:

Used for surveying on a moving platform. Used to take measurement at pre-set time. Can be used to map streets or sea survey.

2.6 KEY PARTS OF THE GPS RECEIVER

(1) GPS SENSORS (Fig 2.6a)

The GPS Sensors receiver signals from the satellites, which it transfers to the control unit. The sensors must be able to have the carrier-wave ambiguities resolved properly i.e. the number of wave lengths (λ) between receiver and each satellite have to be determined exactly. It carries appropriate antennae for this. For excellent performance the sensor must be set up where a clear view of the sky is facilitated (Cleasby 1993).

Generally the requirement is that there should be no obstructions above 15° degrees elevation (similar to astronomical observation conditions!) The sensors at each field team also must operate in Synchronisation i.e. simultaneous observations at the survey stations.

Examples of Sensors include:

SR 299 (E) and SR 399 (E)

Real-time GPS Surveying
Fast, efficient, productive
Centimetre-level accuracies

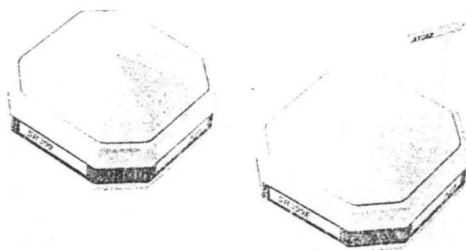

SR299(E) and SR399(E) Dual-frequency GPS Sensors

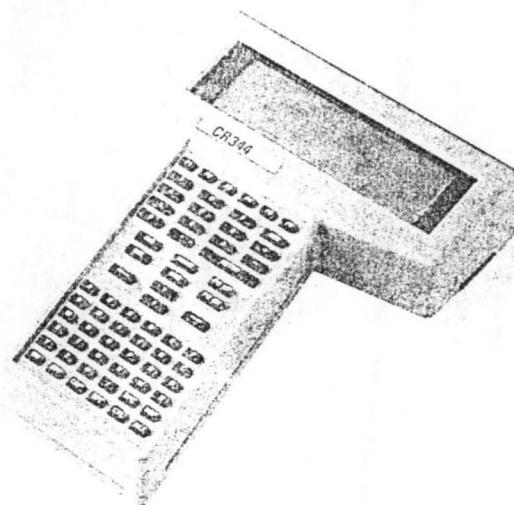

*CR244 and CR344 GPS Controllers
with RT-SKI Real Time Static Kinematic Software*

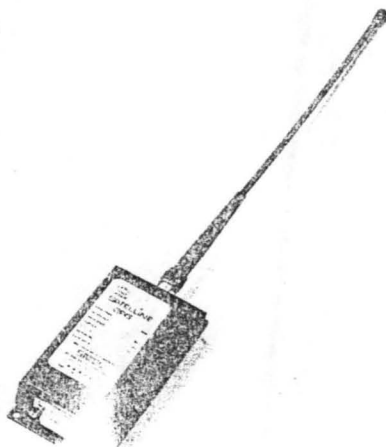

(Source: Leica Manual on
real time GPS Surveying)

```

001111 SELECT Features Load
-----
Code      Description
001      Manhole
002      Road Drain
003      Surface Water Drain
004      Road Gully
-----
CODES: 0001 0002 0003 0004 0005 0006

```

```

001111 Parameters for 001
-----
Diameter: 150 mm
Material: Cast Iron
Cover Ty: Unsealed
-----
CODES: 0001 0002 0003 0004 0005 0006

```

```

001111 SURVEY: Moving
-----
Point Id: 1005420 Code: 0001
Ht. read: 1.900 Hnt. offset: 0.039 m
GDP: 1 4 Rm: 6/6 C: 1.03
Status: 1 [6 of 6] 0 epochs 931 KB
-----
STOP RECALL CODES SCREEN MENU

```

CR 344

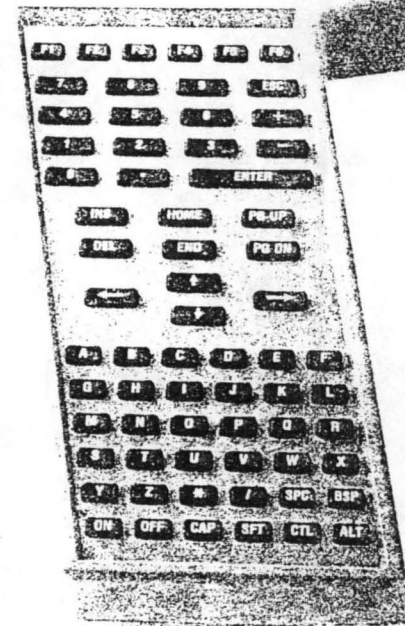

Fig. 2.6 - GPS CONTROLLER: User - definable point identifiers
 (SOURCE: Leica manual on real time GPS Surveying)

The GPS is mounted on a pole when used in the mobile mode or a tripod when used in the static mode. The sensor has to be oriented and a perfect condition is an open East-West horizon (Akanbi '98.)

(2) CONTROLLER (Fig 2.6b And Fig 2.7)

This is the 'brain' in the GPS. It controls all activities and data input, stores and prepares all activities and data input, stores and prepares all activities on the field. It is a semi-computer and provides an interaction between operator and equipment. It has a large display, full alphanumeric key board and menu based operating system. It is used to input identification data about a station. By pressing appropriate keys other information about concentration or presence of satellites or even information as regards status of operation or strength of power supply can be obtained. Examples are the CR 244 or CR 344 GPS controllers. Most also have inbuilt internal memory e.g. CR 333 and card readers for data storage and post-processing.

(3) Batteries/ Charges (power supply)

The various units of the GPS have to be power driven. Usually large 12V 7AH Nicd battery powers the GPS sensor and controller and can do this for 5 to 6 hours continuously before recharging. GKL 23, 230v is a recommended charger that can be used for all batteries. The power level must be monitored while in use to avoid errors and malfunction of the equipment.

(4) CABLES:

Ideal cables should be used for connections with the GPS to avoid damages.

1.8m cable for connecting 12V Nicd batteries to controller/sensor or 2.8m cable can alternatively be used for sensor to controller. Essential cable should be ordered!

ACCESSORIES

These are needed to hold the sensor or carrying the sensor about. They include: -

- Tripod: Heavy duty, wooden, telescopic
- Tripod: Light weight, aluminium, telescopic with carrying strap.
- Aluminium hook for hanging controller on Tripod leg.
- Tribrach with optical plumed.
- Carrier (GRT 44) for mounting GPS Sensor of External antenna.
- Stop/go Kinematic pole, aluminium 1.50m section.
- Holder for attaching controller to stop/go Kinematic pole.
- Quick - Stand for stop/go kinematic pole.
- Adapter for fitting GPS Antenna on vehicle roof rack.
- Soft bag with shoulder strap for holding battery controller, sensor and cables.
- Carrying frame for large soft bags etc.

SOFTWARE:

Appropriate software should be sent for along with the GPS being used!

However common software packages include:

- SPCS software
- SPCS sensor PC - Control Software, 800 controlling GPS sensor from a PC contains 1 manual, 1 set of diskettes, 1 software protection key
- SK1 software and 8K1 software options.
- Bernese Software
- M Star.
- Idrissi, etc.

2.6.3 CONNECTIONS/PROCEDURE OF USE (See Fig 2.8)

The sensor is set up on stations required by mounting on the tripod or Quick stand. It is centred and levelled properly.

It must be connected to the controller and a power supply. It must have a clear view of the sky.

The Controller is similarly connected i.e. to the sensor and power. The sensor antenna must be approximately oriented to the North direction.

Synchronise the two observation points and switch on the controller.

- Press the ENTER button

- Press F1 button
- Press F2 button
- Press CAP button
- Input the identification number of the station
- Press arrow
- Press arrow
- Enter the height of the rod on which the antenna is resting
- Press F1 to show: No of Epochs

GPDOP

No of satellites in orbits

- Press F5 to show the time GPS starts the tracking of satellites etc.

NOTE:

- There must be at least 4 satellite being tracked
- GDOP must be between 1 and 8
- Monitor the iteration of the co-ordinates until satisfactory then switch off and proceed to next station.

FIG 2.8

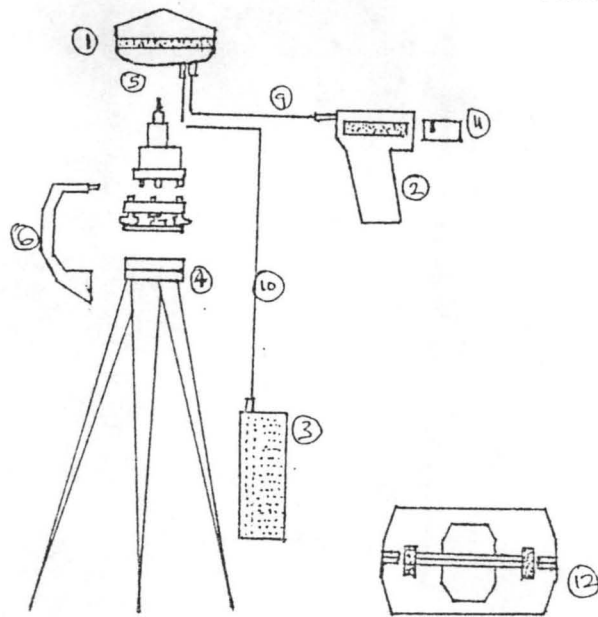

Reference

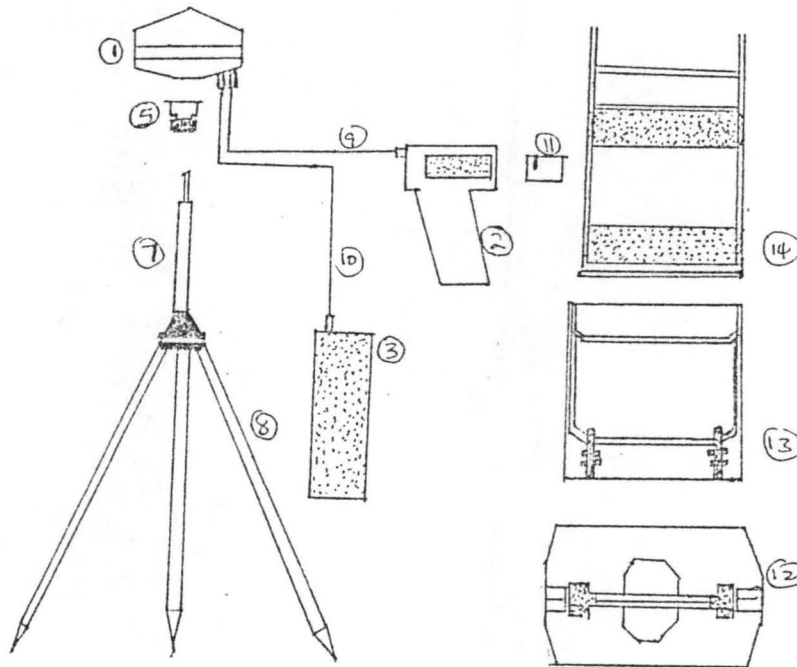

Rover

FIG. 2.8: GPS CONNECTION OF UNITS

(SOURCE: Leica Manual on GPS Surveying)

- (1) GPS Sensor
- (2) Controller
- (3) Power Supply
- (4) Tripod
- (5) Adaptor for fitting sensor
- (6) Height hook
- (7) Stop/Go Kinematic Pole
- (8) Quick stand for kinematic Pole
- (9) Cable for connecting controller to sensor
- (10) Cable for connecting battery to Controller or sensor
- (11) Memory Card
- (12) Hard container
- (13) Large soft bag for sensor
- (14) Carrying frame for large soft bag.

2.7 GPS PROCESSING, ACCURACY AND ADVANTAGES

2.7.1 PROCESSING

Processing of data collected by the GPS is done using appropriate computer software e.g. SK1 Software. Usually these are supplied along with the GPS equipment. It is very important to ensure that as the package is ordered, the appropriate processing software is packaged together.

Most GPS give co-ordinates of stations based on the world Geodetic System 1984 (WGS '84). The centre of ellipsoid being the centre of the earth as its origin. However most packages have ability to transform to Local Systems e.g. Clarke 188 0 system either on Universal Transverse Mercator (UTM) or Nigerian Modified Traverse Mercator).

Note that after observations, the data collected are downloaded into the computer at Home base and the co-ordinates of measured points are displayed for consumption. There are real time GPS that do provide results immediately if 'logged' in to the computer during observations. Examples of software packages are as given already.

The Computer processes without interaction and safes into diskette from where you can make copies. During processing ambiguities must be resolved otherwise you have to re-observe on that station.

2.7.2 ACCURACY

This is the watchword of surveyors. Thus the degree of precision of the GPS result is of vital importance here. If it fails to meet a set standard then its application would be restricted.

The ultimate accuracy of GPS is determined by the sum of several sources of errors. The contribution of each source may vary depending on atmospheric and equipment conditions. GPS accuracy is dependent on ambiguity resolution.

In addition, the accuracy can purposely be degraded by the United States Department of Defence (DOD) using an operational mode called 'SELECTIVE AVAILABILITY' (S/A). S/A is designed to deny hostile forces the tactical advantage of GPS positioning. It is done by introducing some 'noises' into GPS satellite clocks, which reduces their accuracy. When, and if, it is implemented, it constitutes the largest component of GPS errors.

2.7.3 TYPICAL ERROR SOURCES (Fig 2.9)

Satellite clock errors

Ephemeris clock errors

Receiver clock errors

Atmospheric clock errors

Selective Availability errors (S/A)

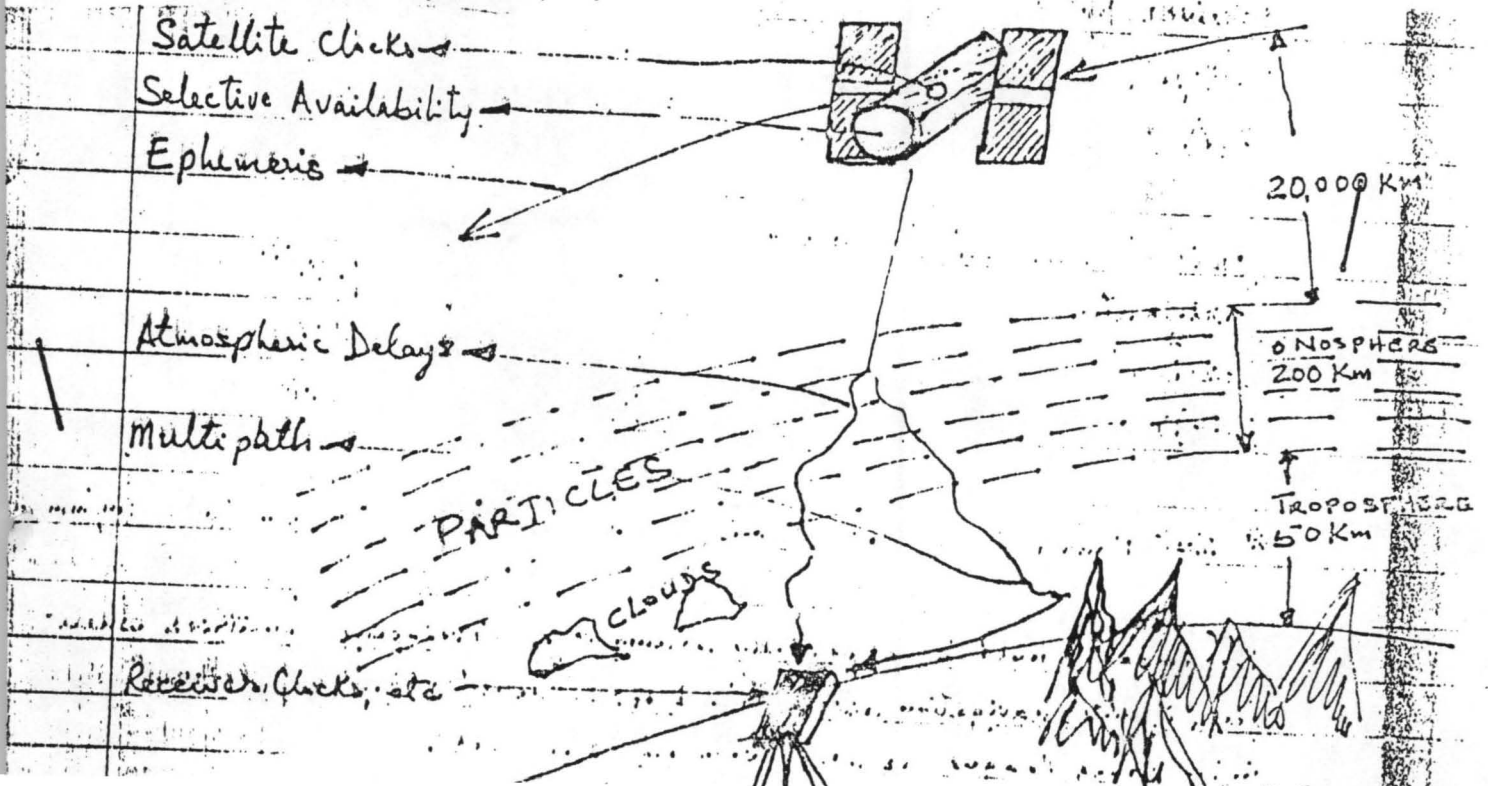

Typical error Budget (in meters)

Per satellite accuracy	Std GPS	Diff. GPS
Satellite Clock	1.5	0
Orbit errors	2.5	0
Ionosphere	5.0	0.4
Troposphere	0.5	0.2
Receiver Noise	0.3	0.3
Multipath (Reflectors)	0.6	0.6
Selective Availability (S/A)	30.6	0

Most manufacturers new high-precision receivers can produce Cm/mm accuracy. This is dependent on factors listed above however.

To calculate the predicted accuracy, multiply the total error by PDOP (Position Dilution of Precision). PDOP is a measure of relative Geometry (Cleasby 1993).

2.7.4 ADVANTAGES OF GPS

GPS is set to revolutionising surveying. Noted advantages can be summarised as:

- (1) **Speed:** Co-ordinates can be obtained in the field in real time where you need them.
- (2) **Accuracy:** With centimetre-level accuracy work can be done independent of previous surveys or controls.
- (3) **One-man system:** Survey party to carry out survey is removed. One or two people can effectively carry out the assignment.

- (4) No special skill required. A bricklayer or farmer can operate and get correct results.
- (5) Independent of weather conditions (can be used in Rain or sun, Night or Day).
- (6) Ease of operation: Special cutting and clearing of survey lines is remove.
- (7) Global networking.
- (8) Increased productivity.
- (9) Many uses (versatile).
- (10) Results readily available in desired form (WGS 84) or local co-ordinates.

2.8 APPLICATIONS

- (1) GIS compatibility
- (2) Control surveys
- (3) Detail, Engineering, Cadastral and Topographic Surveys
- (4) Measurement of Profile, Cross sections and Volumes
- (5) Locating Point, and setting out.
- (6) Seismic Surveys
- (7) Monitoring positions and movements
- (8) Precise Navigation
- (9) High accuracy hydrographic surveying

- (10) Mining, Explorations, Machine control etc.

2.9 SUMMARY OF FACTS ABOUT GPS

- (1) Was developed by the United States of America Department of Defence
To simplify accurate Navigation.
- (2) GPS uses satellites and computers to compute positions anywhere on the
Earth.
- (3) Position is computed from distance measurement to satellites.
- (4) Mathematically we need four measurements to determine exact position.
- (5) The distance to a satellite is determined by measuring how long a Radio
Signal takes to reach us from that satellite.
- (6) Accurate timing is key to the measurements.
- (7) GPS satellites are so high up, their orbits are very predictable.
- (8) The DOD can influence the accuracy of GPS by S/A mode.
- (9) Differential GPS measurements can be much more accurate than standard GPS
measurement.
- (10) GPS positioning is based on the World Geodetic System 1984 (WGS '84) co-
ordinate system.

Minimum equipment sets for real-time GPS Surveying

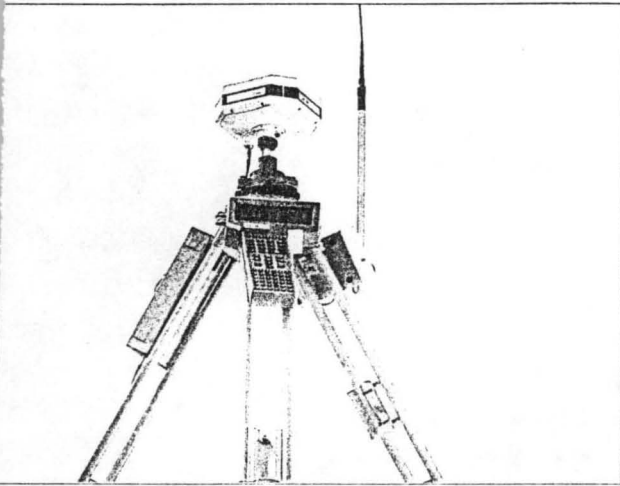

Minimum equipment for real-time reference station.

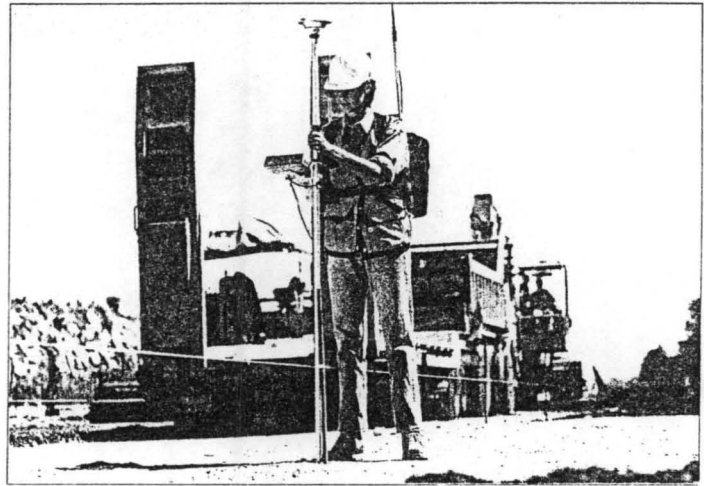

Minimum equipment for real-time rover

Fig. 2.10

(SOURCE: LEICA Manual on Real Time GPS Surveying)

CHAPTER THREE

3.0 DATA CAPTURE

The data capture is an integral part of any assignment. Two approaches were used here: -

- (1) Selection of some points at the Federal School of Surveying (FSS) Oyo; whose co-ordinates are separately determined using a traditional surveying technique (Traversing) and also by using the GPS technique. The co-ordinates obtained from both techniques are compared.
- (2) The second approach is by surveying an area using both methods to compliment each other. The area has no previous control points, hence the GPS was used to provide initial starting points and traversing used to do the actual survey.

These two approaches form the major ways by which GPS can be applied in large-scale surveying. Any other way will have only minor variations from these approaches. Furthermore the second approach is another way of confirming the result from GPS. Indeed, combining both methods and evaluating the accuracy obtained will go a long way in showing the Application of GPS in Large Scale Surveying.

3.1 TRAVERSING - OYO

This involved selection and co-ordination of four (4) points within FSS OYO. These are points used for student's practical over the years. Their co-ordinates have been determined several times over.

The points chosen are:

- XSN 007
- BMSC 310
- R 14
- BMSC³⁰⁴304

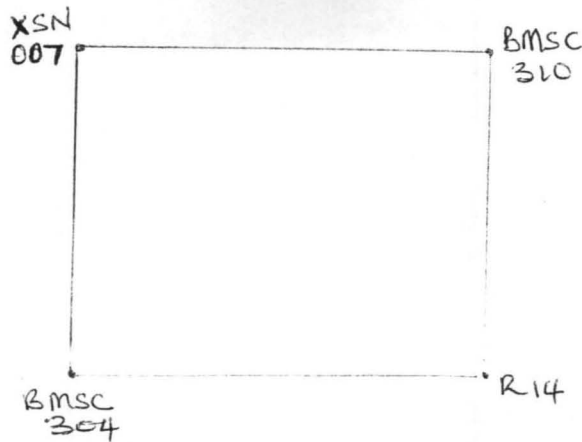

A total station (TC 600) was used to re-co-ordinate these points.

PROCEDURE:

- (1) Set Total Station over the 1st station (control) in this case XSN 007. Perform all necessary station Adjustment.
- (2) Set target to desired height (2.0m) and set up at the next station (BMSC 304).
- (3) Bisect the target with the Total Station and enter all parameters:
 - Identification number of station and its co-ordinates (N,E,H)
 - Height of instrument axis above station (ia)
 - Direction towards the next station (Bearing)
 - Identification number of Target Station (Pillar Number)
 - Target height (ht) above that station.
- (4) Measure the distance, angle and co-ordinates. The co-ordinates of the next Station is automatically displayed.
- (5) Move instrument (Total Station) to the next station previously occupied by the

Target (BMSC 310).

(6) Repeat above operations i.e. steps 1 to 5 until the end of the traverse.

NOTE:

Because of the type of instrument used (Total Station TC 600), the corrections and computations are automatically done, only the result N,E,H are displayed.

3.2 TRAVERSING DAKOGI

This involved a live project: The survey of the Sunti Sugar Company located at Dakogi near Mokwa in Niger State. The area is remote and no previous survey exists within the area. This called for Local origin or GPS application. The latter was chosen.

Three points were created near the site for the GPS stations to serve as controls for the task DKG/GPS1, DKG/GPS2, DKG/GPS3. The first station was chosen near a stream appearing on the topographical map covering the area (sheet). This was so chosen that the longitude and latitude could be scaled for the GPS initialisation.

A total of 58 stations bounded this plot of Land, hence by survey regulations Azimuth had to be observed in between. It was however decided that advantage of the GPS be maximised by observing again on the two middle stations i.e. on stations PB/MK/615. The pillars numbers used were issued by the Niger State survey division. Thus a total of five points were observed using the GPS to control the work.

Figure 3.1 shows the Land area as appears on the topo sheet covering the area and fig. 3.2 is the Recce diagram showing the stations bounding the site.

OBSERVATION:

Station From	Angle	Distance	Station to	Remarks
GPS - 2	182 12 29	-		Check Angle
639582*1	142 36 15	213.490	Peg 1	Open'g Angle
PEG 1	208 12 50	198.080		
PBMK 600	50 40 30	82.920		
601	267 23 12	288.400		
602	178 24 02	245.000		
603	163 17 23	228.600		
604	180 42 50	221.150		
605	176 16 13	392.750		
606	182 44 20	221.500		
607	176 40 18	311.650		
608	180 12 48	303.350		
609	181 28 07	243.690		
610	181 32 42	186.220		
611	171 47 37	177.100		
612	141 36 36	172.530		
613	240 31 25	236.600		
Peg 2	213 06 50	338.250		
Peg 3	171 21 36	256.250		
Peg 4	231 16 40	255.930		
Peg 5	150 42 14	168.650		
Peg 6	189 34 48	140.750		
Peg 7	170 58 33	187.550		
Peg 8	161 02 08	295.150		

Peg 9	189 42 56	234.950		
Peg 10	183 39 03	142.200		
Peg 11	220 33 08	80.000		
Peg 12	159 45 15	125.700		
PBMK 614	273 09 45	156.650		
PBMK 615	179 38 43	284.100		
616	179 49 16	282.100		
617	180 38 21	395.700		
618	179 47 40	397.100		
619	179 59 26	395.000		
PBMK 620	179 59 11	396.100		
621	90 59 35	300.000		
622	179 57 18	350.000		
623	179 57 08	216.100		
624	179 59 18	395.100		
625	269 59 36	210.00		
626	180 08 37	216.100		
627	179 55 54	395.500		
628	179 57 20	393.100		
629	179 59 12	391.700		
630	180 00 24	392.700		
631	256 57 40	290.350		
632	180 32 32	400.000		
633	185 21 03	250.400		
634	195 24 06	167.800		

635	182 23 27	306.000		
636	183 54 02	305.200		
637	179 57 36	352.500		
638	185 31 46	145.100		
639	155 10 14	326.600		
640	193 00 40	397.850		
641	180 06 45	400.000		
642	179 46 46	398.500		
643	168 15 10	129.190		
GPS3	171 38 56			

TABLE 3.1 - Observed angles and distances

3.3 GPS OBSERVATION - OYO

The type of Equipment available was the Leica SR299 model - Post

Processing type, working on the differential mode i.e. consists of a Reference and a Rover.

Instrument: Wild GPS 200 consisting of 6 channels

GPS SR 261 Single Frequency Sensor

Wild AT 201 external antenna

CR 233 and CR 244 GPS controllers.

The stations occupied here are the same with that listed under traversing - Oyo i.e. stations

XSN 007

BMSC 310

P1

R 14

BMS 304

Station XSN 007 served as reference for all other stations. The Reference equipment was set here permanently while the Rover went round the other stations in turns.

SETTING UP

At each station (whether Reference or Rover) the equipment is set up on the desired station point and levelled. The accessories are properly connected to each other via cables e.g.

- Connect battery to sensor
- Connect sensor to antenna

- Orient antenna to the North
- Connect sensor to controller.
This operation is similar both at Reference and Rover stations.

MEASUREMENT:

Having connected the equipment properly, switch on the controller and select appropriate format from menu. Enter relevant information pertaining to other station. E.g. Longitude (λ) and Latitude (ϕ) of the area (scaled from topo map). For this work, the same ϕ , λ were used since within the same area. Parameters used include:

$$\phi = 07\ 52\ 30\ \text{North}$$

$$\lambda = 03\ 57\ 00\ \text{East}$$

- rough height of station above mean sea level (MSL) = 300m
- height of antenna (ht) above station $0.039 + 0.222 = 0.261\text{m}$
- at Rover station $ht = \text{height of target (1.5m)} + \text{antenna offset (0.039m)} = 1.539\text{m}$

Crosscheck the GDOP - 3 very okay then start to track noting the time of starting. Monitor the observation and ensure that GDOP does not exceed 8.

Record the point.

Measure for 20 to 30 minutes depending on distance between Reference and Rover stations.

Note the time of stoppage.

Note that there must be clear view of the sky at any station otherwise the observation will be hampered. At station BMSC 304 there were obstructions and in the course of tracking the GDOP was not very good so the timing was increased.

All the stations are occupied in turns by the Rover. All the while the Reference kept working. If the distances were far communication equipment (walkie-talkie) would be very important otherwise the battery could run off without any useful work done.

3.4 GPS OBSERVATION - DAKOGI

The same equipment was used. The Reference was GPS 1 pillar and others were occupied in turns by the Rover. Having finished the controls the extra two points were occupied and referred to the same Reference stations GPS 1. So reference was DKG/GPS1, Rover went from DKG/GPS2, to DKG/GPS3 then to PBB 604 and finally to GPS 605.

It is worthy of note that during the observation a light rain started, but did not stop the working of the equipment.

It is worthy of note also that planning or field preparation i.e. survey design is very important in GPS use. It takes the place of Recce in traditional surveying. It involves going to the SK1 software before the field day, studying how the sky will appear, the availability of satellites the visual display of the satellites, the DOP range etc. In short from the software one can determine the best period of observation at a particular place on a particular date. This eases the work and ensures optimal use of time and resources.

3.5 SOME PRACTICAL HINTS IN GPS SURVEY

- (1) Check tribach for bubble setting
- (2) Level and centre bubble
- (3) Cross-check Antenna height properly
- (4) Cross-check station number
- (5) Use Radio contact (Walkie-talkie) to keep in contact
- (6) Orient Antenna properly for precise survey
- (7) Use field sheets for guide lines to elucidate e.g. point number, date of observation,

Sensors serial number, Height Reading, type of set up; Time started, time stopped, number of epoch, GDOP, Navigation position etc. All these help especially when down loading.

CHAPTER FOUR

4.0 COMPUTATION/ANALYSIS

Computation means calculation in an organised manner. Computation comes up in everyday survey activity. Raw data do not lend themselves to organised presentation hence the need to refine, synthesise and remove errors from observed values. Results are also evaluated to assess if they meet standards. Computation prepares observation for final plotting.

For this task the computation is divided into two viz.:

- (1) GPS computations - for co-ordinates of points determined by GPS equipment.

The computation here is purely by application software (SK1) which does not

Allow for much human input. The computer does everything and gives the

Result(s) only.

Computation of traverse co-ordinates - For traverse run in Mokwa. The

Computation is done on specially designed format for Traverse computations.

For analysing the results, comparison is made of GPS co-ordinates with those previously known and the accuracy of the traverse is compared with the minimum standard for tertiary traverses for the second

4.1 GPS COMPUTATIONS

In GPS, the computation is called data processing. During the process data collected on the field must be IMPORTED to the computer. This can be done in any of 2 ways:

- (1) Using ~~card~~ Reader or
- (2) Down loading directly from controller to the personal computer PC.

The card reader is similar to a back up diskette where data can be held and Retrieved at will. The processing is effected using specially designed software - provided separately and purchased separately in CD-ROM or Diskette. For Leica (i.e. the one used for this assignment) the SK1 software was used. Another similar processing software is MSTAR for Magellan instruments.

Three steps are involved in GPS computation:

- Down Loading
- Processing
- Transformation.

4.1.1 DOWN LOADING (SK1 SOFTWARE)

Simply implies transferring data from controller or memory card to the CPU for processing. To do this, Attach cable to serial Porte (Controller) i.e. make necessary connections - battery - controller - CPU. Go to manager, then click twice (for Windows 95). For windows 98 start and go to programmes.

From programme click SK1 2.1

Select measurement; click GPS controller.

Select memory card; click OK (read message and clicks Ok after operating the controller).

Select all and copy.

Select OK

Select all and insert

Select all and save as (NBTE)

Click OK after inserting path

Click close (down loading stops).

Repeat the above procedures for the Rover controller. Crosscheck various data).

The down loading is completed.

Go back to Icon environment to start processing. Connect mouse back if you removed it.

4.1.2 PROCESSING

The GPS works on the WGS 84. The data collected are iterated values of Longitudes, Latitudes and heights. The processing goes through the data to smoothen out, Edit (cycle slips) and resolve ambiguities. During processing ambiguity must be resolved otherwise one has to go back to the station for re-observation.

During processing also, the adjustment is carried out for Baseline relative positioning and three - Dimensional network adjustment. It uses non-differenced or differenced phase and range observation computations to geometric relative positions. These adjustments generate reliable statistics and detect any remaining errors. This

forces the adjusted co-ordinates to be consistent over all observations in the campaign.

After adjustment, processing continues with data analysis (result analysis). Analysis for repeatability and accuracy before finally archiving results. Data analysis includes checking whether the internal consistency of results and the results of repeated base lines meet the desired accuracy.

The final processing step is to present the results, and to archive all text, diskettes, tapes etc in an orderly manner.

Note that the computer, using the software, processes without interaction and saves into diskettes from where copies are made.

From the result display, the package will state whether or not the ambiguities were completely resolved or not, and how reliable the result is. It will state the:

- (1) Points considered
- (2) Operation information
- (3) Satellite information
- (4) Project setting
- (5) Satellite selection (any disabled satellites)
- (6) Processing parameters
- (7) Initial co-ordinates
- (8) Variance - Covariance matrix

X,Y,Z are in datum two

M is the rotational matrix $f(w, \phi, k)$

$$K = \tan^{-1}(ab) - \tan^{-1}(AB)$$

$$S = \frac{ab}{AB}$$

TX, TY, TZ are translational elements.

The above is for transformation from WGS 84 to Local datum.

Another approach will be to translate from the Geographical Co-ordinates (Latitude ϕ , Longitude λ and height h) to Cartesian co-ordinates (Northings N, Eastings E and height H) in the reference system using the transformation tables.

For $\phi, \lambda, h \longrightarrow N, E, H$ in UTM

Transformation of co-ordinates from Geographic to Grid.

Formulae

$$N = (I) + (II) P^2 + (III) P^4 + A6$$

$$E1 = (IV) P + (V) P^3 + B5$$

If the point is east of central meridian

$$E = 500,000 + E1$$

And, if it is West of the Central Meridian

$$E = 500,000 - E1$$

E1 and $D\lambda$ are always positive

Convert $D\lambda$ into seconds and move the decimal point four places to the left.

This is equal to P.

I to V, A6 and B5 are obtained from the projection tables.

And for ϕ, λ, h N,E,H in NTM we have

$$X = M + I/2 \tan \lambda VW^2 + BW^4$$

$$Y = VW + CW^3$$

The latter approach was used. A program written by surveyor Ajibade of the Federal School of Survey (FSS) Oyo was employed and was simply used to obtain our result.

Station	Longitude (λ)	Latitude (ϕ)	Height
XSN 07	03 57' 00".5809	07 50' 31".8408	309.989
BMS C304	03 57 03.5485	07 50 31.0694	309.570
P1	03 57 06.5768	07 50 31.1551	308.774
R14	03 57 04.0922	07 0 36.5213	304.118

TABLE 4.1

RESULT OF POINTS IN UTM

Stn	Northings (N)	Eastings (E)	Heights (H)
XSN 07	866889.857	604 753.484	
BSMC 304	866866.375	604 844.430	
P1	866869.216	604937.172	
R14	867033.840	604860.700	

Result of points in NTM

Stn	Northings	Eastings	Heights
XSN 07	424 788.050	170112.294	
BMSC304	424 764.242	170203.161	
P1	424766.751	170295.918	

See appendix..† For point out of tables 4.1 and 4.2)

RESULTS OF CONTROL POINTS DAKOGI (MOKWA)

Station	N(M)	E (m)	Ht
DKG GPS 1	1014614.799	759108.413	
DKG GPS 2	1014388.463	758849.337	
DKG GPS 3	1014160.813	758608.169	
PBMK 615	1009526.412	758501.849	
PBMK 616	1009765.998	758349.158	

These are the documented (archived) results, which are desired co-ordinates.

The GPS co-ordinate of point BMSC 310 which was unfortunately omitted was obtained from the survey record of the Federal School of Surveying Oyo and added to those on table 4.4

4.2 TRAVERSE COMPUTATION

As mentioned under Data acquisition, Traversing was combined with GPS technique to carry out a productive assignment - The Survey of Sunti Sugar Company land. Thus using normal traverse computation technique the co-ordinate of all stations bounding the site was obtained. First, the co-ordinates of the 'controls' established by GPS was obtained as seen from 4.1, then these were used to compute the traverse. Remember that we compute for Bearings of each line, then the partial co-ordinates, the co-ordinates of each point, evaluating accuracy, and, finally

adjusting the co-ordinates. These are all done on standard computation formats

(sheets) and is given in Appendix 2.

The extracts of co-ordinates of points obtained from the traversing are given under the abstracts of results below.

4.3 ABSTRACTS OF RESULT

GPS RESULTS (OYO) IN NTM

STN	N	E	H	REMARKS
XSN 07	424,788.050	170	112.294	
BSMC3 04	424,764.242	170	203.161	
BSMC 310	424,875.421	170	096.112	
P1	424,766.751	170	295.918	
R14	424,931.657	170	220.030	

TABLE 4.4

TRAVERSING RESULTS (OYO) IN NTM

STATION	N	E	H	REMARKS
XSN 07	424 788.032	170	112.275	
BMSC 304	424 764.216	170	202.883	
BMSC 310	424 875.049	170	095.164	
R 14	424 931.558	170	220.302	
P1	424 766.765	170	295.886	

TABLE 4.5

GPS RESULTS (MOKWA) IN U.T.M.

STATION	N	E	H	REMARKS
DKG GPS 1	1014 614.799	759 108.413		
DKG GPS 2	1014 388.463	758 849.337		
DKG GPS 3	1014 160.813	758 608.169		
PBMK 615	1009 526.412	758 501.849		
PBMK 616	1009 765.998	758 349.158		

TABLE 4.6

TRAVERSING RESULTS FOR FARMLAND IN MOKWA

STATION	N(m)	E(m)
PBMK 600	1,014,026.826	758 680.502
" 601	1,014,026.329	758 763.431
" 602	1,013,738.190	758 774.859
" 603	1,013,493.778	758 791.399
" 604	1,013,279.788	758 946.763
" 605	1,013,071.820	758 946.925
" 606	1,012,711.944	759 104.158
" 607	1,012,504.981	759 183.033
" 608	1,012,220.717	759 310.734
" 609	1,011,943.564	759 434.007
" 610	1,011,718.456	759 527.297
PBMK 611	1,011,544.577	759 593.923
" 612	1,011,389.949	759 680.247
" 613	1,011,324.096	759 839.728
" 614	1,009,393.770	758 585.199
" 615	1,009,526.412	758 501.849
" 616	1,009,765.998	758 349.158

"	617	1,010,003.409	758 196.774
"	618	1,010,338.790	757 986.756
"	619	1,010,674.600	757 774.791
"	620	1,011,008.600	757 563.896
"	621	1,011,343.483	757 352.334
"	622	1,011,187.694	757 095.916
"	623	1,011,005.708	756 796.903
"	624	1,010,893.192	756 612.376
"	625	1,010,687.410	756 275.004
"	626	1,010,866.663	756 165.634
"	627	1,011,051.406	756 053.509
"	628	1,011,389.272	755 847.900
"	629	1,011,724.931	755 643.283
"	630	1,012,059.349	755 439.316
"	631	1,012,394.647	755 234.873
"	632	1,012,597.799	755 442.272
"	633	1,012,874.953	755 730.634
"	634	1,013,030.858	755 926.543
"	635	1,013,096.708	756 080.861
"	636	1,013,204.946	756 366.990
"	637	1,013,293.232	756 659.155
"	638	1,013,395.431	756 996.472
"	639	1,013,423.923	757 138.730
"	640	1,013,616.595	757 402.399
"	641	1,013,772.951	757 768.187
"	642	1,013,929.425	758 136.261
"	643	1,014,086.722	758 502.353
	DKG GPS 3	1,014,160.813	758 608.169

TABLE 4.7

4.4 COMPARISON AND ANALYSIS OF RESULTS

(1) GPS results:

Tables 4.4 and 4.5 give the GPS results and that of traversing for the same (5) points. These are 3 results obtained at different times. We notice that there are differences in the decimal places of the values (co-ordinates). The questions are-

1. Are the difference(s) appreciable that they must be attended to, or are they negligible?
2. What caused the difference(s)?
3. What can be deduced or concluded?

We shall examine two of the points in turn

	N	E
1. Point XSN 07. ° GPS	424 788. 050	170 112 .275
ε Traverse	424 788. 032	170 112.294

This is the central control point. It is stationed at the Roundabout inside the Federal School of Surveying Oyo. It is a control that has been established for many years and infact is the major reference point even before GPS came to be. The difference between the co-ordinates is very small - negligible. What caused the difference?

Obviously no measurements can be carried out two different times without small difference. Moreover by different observers at different times. This is to be expected.

What can be concluded? - Simply that the result is satisfactory. More so that the GPS has been used on this point several times and a consistent result has always been obtained.

	N	E
ii. Point BMSC 304: GPS	424 764. 242	170 203. 161
Traverse	424 764. 216	170 202. 883

$$\partial N = 0.026 \qquad \partial E = 0.278 \qquad \therefore = 0.279\text{m}$$

For a single point an error of the magnitude is rather great. What caused the error? Simply the vicinity of the station. In chapter (iii) it was mentioned that interference of signals could down grade the result. This station has some likely factors to affect it e.g. Transformer and electric lines, Mango Trees partially shielding it and Buildings within the vicinity.

What can be concluded? Care has to be exercised in choosing GPS station if good, reliable results are to be expected.

From the comparisons made above, and examine the other points, it can be seen that others fall in-between these two extreme cases.

It can also be observed that apart from BMSC 304, as the distance between Reference and Rovers increases there is a tendency for the error to increase.

In traversing, errors are always adjusted over all other stations believing that the error is consistent over the whole traverse. This however may not be, in GPS, one point is adjusted relative to only one other one. Of course if the Reference is

the one in error then a mightier problem is the result - all the points determined would be affected.

(2) Traverse Result:

For the traverse in Mokwa, the survey standard of assessing any traverse is used.

Any tertiary traverse must have accuracy not less than 1/3000 otherwise the survey is regarded as not being acceptable.

For this assignment it is checked in two places:

- (1) From beginning to the 29 station - where azimuth should have been observed and from the 29th station to the end of the traverse.

As the traverse was carried out, it is almost impossible for any errors to go undetected.

First, many stations are involved. Secondly the control for two distinct sets hence the errors cannot hide anywhere. If there is a favour to the 1st segment it will be revealed in the second segment so no room for hiding.

Since it was a productive job, this standard is highly regarded because any short fall will make the job rejected by the ministry. Also the ministry will check every bit of the data to ensure acceptability before it is certified.

As stated above, there were two loops that made up the survey. One loop started on DKG/GPS 2 -GPS 1 Enroute River Iko's Right Bank and closed on GPS -PBMK 615 to GPS -PBMK 616. The closing angular error of 53" is very much within acceptable limits of $30''\sqrt{n}$. The second loop had a closing misclosure of 42" as against 162" permitted. Hence the angular measurement was very much acceptable.

For the Linear Measurements, the accuracies of 1/6000 and 1/9000 obtained for the two loops respectively dusts the allowable value of 1/3000. Hence from any survey perspective, we see that the use of GPS for the control can be safely said to be acceptable.

Discussion of Results

From the Results and analysis above it can be concluded that there is no significant difference in results from GPS surveying and traditional techniques of surveying. Both methods can guarantee the expected accuracy when used to survey any plot.

	Differences	Remarks
XSN 07	0.019	Negligible
BMSC 304	0.279	Appreciable but explained
Others	0.0 - 0.3	Tolerable

Accuracy assessment

Loop 1 Angular misclosure = 53"; allowable	162"
Loop 2 Angular misclosure = 42"; allowable	62"
Loop 1 Linear Accuracy 1/6000 allowable	1/3000
Loop 2 Linear Accuracy 1/9000 allowable	1/3000

Thus it can be seen that $H_o ; b_o = b_i$ and the GPS can be safely used to perform all survey operations in our locality.

CHAPTER FIVE

SUMMARY, CONCLUSION AND RECOMMENDATION.

5.1 FINDINGS

Surveying has been progressive over the years. From use of simple chains and tapes, measurements / positioning of points have continued to metamorphous until today where we have the new wave of GPS technique.

The innovations (Recent advances) could be grouped into three major categories of:

- Field instrumentation and
- Data processing
- Research

These have had tremendous impact in the surveying world especially with the GPS today.

To a layman GPS is simply magical. Closer study however will reveal that the wave of innovations in technology is what has caught up in surveying. High technique advances has brought about this new sophistication.

This work has indeed confirmed that the GPS is workable in survey work.

First depending on the size, scope and purpose, an area could be entirely surveyed using the GPS technique only. Here the whole points demarcating the plot will be occupied in turns with the GPS equipment. The differential method of course will be most recommended.

The hand held GPS, and the Absolute mode have similar working principles. However to survey an area the accuracy expected will be very unacceptable. They could only be used for checking and exploratory surveys.

Secondly, the GPS could be used in conjunction with existing survey methods as shown in the report. With GPS capability of yielding control accuracy, a framework could be provided and other surveying methods (e.g. Traversing) used to complete the exercise. This is demonstrated in the project where a traverse of the Sunti Sugar Company upland farmland had a total of 58 stations. The land was carved out and so needed every input of old survey technique. However the absence of control points necessitated the establishment of GPS stations. On the whole Five (5) GPS stations were established to serve as control. Three (3) at the starting point and two (2) to control the Azimuth in the middle.

Two separate traverses were thus run and both yielded satisfactory accuracy of 1/6000 and 1/9000 respectively which are acceptable. The normal ordinary ensuring techniques were used for the angles and distances hence the result cannot be faulted.

We therefore find that the GPS can indeed be applied (and in fact is been applied) successfully in our area. The results from comparison with existing stations and result from analysing the accuracy of a traverse run in conjunction with the GPS give ample credence to this fact.

GPS is conclusively an offshoot of recent advances of surveying instrumentation, Data processing and modern day Research.

5.2 SUMMARY:

It may be worth while highlighting some of the benefits of GPS techniques over conventional surveying methods that give it so much credence and which often tend to make people view it as a separate entity from surveying:

- (1) Weather independence, whereas most traditional techniques are weather dependent, the GPS is absolutely unaffected by weather condition.

- (2) Does not require line of sight.
- (3) Gives high Geodetic Accuracy - with minimum effort.
- (4) GPS can be operated day and Night.
- (5) GPS is quicker and requires less manpower.
- (6) Gives common co-ordinate system i. e. WGS'84
- (7) Has wide range Application.
- (8) Competitively priced.

These obvious advantages however do not cancel the fact that the GPS is still an off shot of the surveying techniques. It has made Large Scale Surveying an area of venture by Remote sensing techniques - an effort that has been very difficult hitherto.

The outline principle is still of measures distance from satellites using time dependent codes.

5.3 CONCLUSION

This project has been silent on heightening points by GPS. A small problem could come up in heightening using the GPS. Heights determined using GPS are referenced to the WGS'84 Ellipsoid, which is mean spheroid for the whole earth. However, normal heights are referred to the Geoid or Mean Sea level (MSL) .The Geoid and the Ellipsoid are not the same. Moreover different continents have their best fitting reference spheroids (In Africa and Nigeria in particular we use Clarke's 1880 spheroid) which are adopted for heightening, hence the Geoidal separation must be known, with the GPS the separation between the Adopted reference spheroid and the WGS ' 84 must also be established (fig 5.1). The effect of all these are that heights from GPS can sometimes be very inaccurate to some meters. Therefore great care must be exercised in heightening using GPS and a lot more computation is involved.

Having stated the above limitation one can conclude that GPS and indeed Remote Sensing can be used in large-scale surveying. It is worth mentioning here again that GPS is an improvement on surveying. A compliment not a substitute or rival.

In the traverses carried out, accuracies of 1/6000 and 1/9000 were obtained at the end of computations. Minimum standard acceptable is 1/3000. Considering that the method used in data acquisition is for ordinary work, the results are quite acceptable and satisfactory.

5.4 RECOMMENDATIONS

Having reached this far, and from the experiences gathered, the following recommendation are made:

1. There are different types of GPS sets. Care must be taken in time of choice. Just as there are different grades of Theodolites for meeting different precision and targets so are GPS equipment many and varied. GPS is BEST OPERATED BY A PROFESSIONAL.
2. Data being captured must be monitored. Many operators simply say, set the instrument at a station for 20minutes or 30minutes etc. This should not be. During observation the prevailing conditions especially the GDOP must be monitored. If need be, the time at each station should be increased.
3. There is need for proper 'Recce' before going to the field i.e. field preparation. Effort should be made to get initial values correct.
4. Operating manual for each set must always be made available. Observe necessary observation condition.

5. Remember GPS is an improvement on surveying not a substitute, a compliment a rival. Get a professional to operate it. Also GPS is not error free. It is man-made and can fail. Don't just assume that it can do everything. The results on the 1st test shows that the further the Rover is from the Reference, the greater the difference in co-ordinates. Watch out the computer, Garbage in, Garbage out (GIGO).

Thank you.

REFERENCES

1. Ajakaiye, D.E. (1985) "Surveying Applications in Geophysical studies" in The Nigerian Institution of Surveyors. Annual Olumid Memorial lectures. Pp53-63.
2. Ajibola, M.O. (1998) Comparison of co-ordinates determined by Global Positioning System and classical Survey method project Report, F.S.S. Oyo.
3. Akanbi S.O. (1998) The Boundary demarcation and perimeter Survey of the Office, estate, farms and industrial sites of the Sunti Sugar company limited, Mokwa. Technical Report.
4. Allan, A.L et all (1968) Practical field Surveying and Computations. Heinemann: London.
5. Cleasby C. (1993) GPS controls for London's new water Ring. Main Surveying.
6. Ezeigbo, C.U. (1998) Principles and Applications of Geographic information Systems series in Surveying and Geoinformatics Department of Surveying Unilag. Lagos.
7. Fajemirokun, F.A. (1983) The Profession of Surveying and its contribution to National Development. Annual Olumide memorial Lectures. NIS Lagos. Pp 19-38
8. Igbokwe, J.I. (1996) Mapping from Satellite Remote Sensing EL'DEMAK New Jersey Enugu
9. Johnson B (1998) GPS hand manual. Unpublished.
10. Leica Heerbrugg Switzerland. (1995) Real-time GPS Surveying OSW and open survey world in
11. Leica (1996) GPS Surveying. Equipment list: Accessories and software. Heerbrugg Switzerland.
12. Leica (1998) Basic Theory. GPS basic course. Heerbrugg Switzerland.
13. Nsofor G.N. (1998) " Geographic information system (GIS) in Urban and Regional planning" in The Surveying Focus, NISS FUT Minna.

14. Nwilo P.C. (1998) " Data acquisition by Ground Survey Methods" in Principles and Applications of GIS edited by Ezeigbo C.U. Dept of Minna..
15. Ogunlami, J.A. (1998) " Some factors for consideration in Establishing Enduring and useful Surveying and Mapping Policy for Nigeria for sustainable development" in Evolving a Surveying and Mapping policy for Nigeria, 33rd AGM of NISS.
16. Okoronkwo I.V. (1998) "Technology trends in Surveying and Mapping " in Evolving surveying and mapping policy for Nigeria, 33rd AGM of NISS.
17. Okoronkwo I.V. (1999) Surveying in the New Millennium: Challenges to the Nigerian Surveyors.
18. Olaleye J.B et all (1999) GPS/GIS Integration: New application areas for Surveyors.
19. Omilabu J.O. (1999) Computer Aided Surveying. A working paper in a 4-week Training programme organised by NBTE/FSS Oyo.
20. Sokkia (1996) New GPS Systems "Technical support folder". GPS Configuration Guide. NCAD corporation. Tokyo Japan.
21. Wells, D et all (1987) Guide to GPS positioning. Canadian GPS Association.
22. Wright A.F. (1990) GPS Training Course Global Surveys Ltd. Birmingham Great Britain.

APPENDIX 1

```
#####
#   GE_PS PROJECT SETTINGS                                     #
#####
```

```
Processing software : Leica SKI / Data processing version 2.1
General header      : FEDERAL SCHOOL OF SURVEYING OYO
Project name        : GPS PRACTICE
Coordinate system   : WGS84
Time                : All results in local time (GPS + 0.00 hr)
```

```
#####
#   GE_PP PROCESSING PARAMETERS                             #
#####
```

```
Cut-off angle (deg)      : 15
Tropospheric model       : Hopfield
Ionospheric model        : Standard
Ephemeris                : Broadcast
Data used                : Use Code and Phase
Phase Frequency          : L1
Code Frequency           : L1
Limit to resolve ambiguities (km) : 20
a priori rms (mm)        : 10
Sampling rate for static (sec) : Use all
Phase processing         : Automatic
Cycle slip detection     : Phase check & loss lock
  flag
Update rate for kinematic (epoch) : 1
Min. time to fix amb. - L1 only (min) : 9
```

```
#####
#   GE_SS SATELLITE SELECTION                               #
#####
```

Manually disabled satellites : None

```
#####
#   GE_IC INITIAL COORDINATES                               #
#####
```

Reference :

```
Point id : XSN 07
  X 6304323.9164 m      Y 435269.8296 m      Z 864640.3904 m
  Lat 7 50 34.61638 N  Lon 3 56 58.58946 E  h 467.9390 m
```

```
#####
#   BASELINE RESULTS                                       #
#####
```

Table

APPENDIX 1

Rov:BMS C304 Ref:XSN 07 Amb:Y Proc: L1 phase 10/20/99 08:50:00
 Cartesian :
 X 6304320.4636 m Y 435360.7285 m Z 864616.8600 m
 dX -3.4528 m dY 90.8989 m dZ -23.5304 m
 sX 0.0028 m sY 0.0011 m sZ 0.0008 m
 Geodetic :
 Lat 7 50 33.84514 N Lon 3 57 1.55714 E h. 467.5189 m
 dLat -0.77123 dLon 2.96768 dh -0.4201 m
 sLat 0.0006 m sLon 0.0012 m sh 0.0028 m
 Distance :
 Slope 93.9586 m sSlope 0.0013 m

Rov:P1 Ref:XSN 07 Amb:Y Proc: L1 phase 10/20/99 09:21:30
 Cartesian :
 X 6304312.9255 m Y 435453.2058 m Z 864619.3576 m
 dX -10.9909 m dY 183.3762 m dZ -21.0328 m
 sX 0.0015 m sY 0.0005 m sZ 0.0007 m
 Geodetic :
 Lat 7 50 33.93078 N Lon 3 57 4.58541 E h. 466.7220 m
 dLat -0.68560 dLon 5.99594 dh -1.2170 m
 sLat 0.0006 m sLon 0.0005 m sh 0.0015 m
 Distance :
 Slope 184.9054 m sSlope 0.0005 m

Rov:R 14 Ref:XSN 07 Amb:Y Proc: L1 phase 10/20/99 08:14:45
 Cartesian :
 X 6304291.1289 m Y 435375.3965 m Z 864782.0290 m
 dX -32.7875 m dY 105.5669 m dZ 141.6386 m
 sX 0.0010 m sY 0.0004 m sZ 0.0003 m
 Geodetic :
 Lat 7 50 39.29640 N Lon 3 57 2.10074 E h. 462.0690 m
 dLat 4.68003 dLon 3.51128 dh -5.8700 m
 sLat 0.0003 m sLon 0.0004 m sh 0.0010 m
 Distance :
 Slope 179.6688 m sSlope 0.0004 m

* INDICATES POINTS NOT RESOLVED AND SO NOT RELIABLE

data no= 1

NTM COORDINATES

STATION	LATITUDE	LONGITUDE	HEIGHT	EASTING	NORTHING
7 50 31.8408 3 57 0.5809					
XSN 07	7 50 31.8408	3 57 0.5809	309.989	170112.294	424788.050
BMS C304	7 50 31.0694	3 57 3.5485	309.570	170203.161	424764.242
P1	7 50 31.1551	3 57 6.5768	308.774	170295.918	424766.751
R14	7 50 36.5213	3 57 4.0922	304.118	170220.030	424931.657

data no= 2

UTM COORDINATES

STATION	LATITUDE	LONGITUDE	HEIGHT	EASTING	NORTHING
7 50 31.8408 3 57 0.5808					
XSN 07	7 50 31.8408	3 57 0.5808	309.989	604753.484	866889.857
BMS C304	7 50 31.0694	3 57 3.5485	309.570	604844.430	866866.375
P1	7 50 31.1551	3 57 6.5768	308.774	604937.172	866869.216
R14	7 50 36.5213	3 57 4.0921	304.118	604860.700	867033.840

□

LAND SURVEYING DEPARTMENT, FEDERAL POLY, BIDA

State NIGER Closing Error for 29 Station 53" Surveyor _____

Date 27-30/5/98

Town DAKOGI (MOKWA) Bearing (True or Colony) _____

Computer _____

Date 30/6/98

(2) Back Bearing Observed Angle Forward Bearing	(3) Com to Bearing	(4) Corrected Bearing	(5) TRUE HORIZ DISTANCE	(6) DN	(7) Arith Sum	(8) DE	(9) Arith Sum	(10) UNCORRECTED CO-ORDS CORRECTION CO-CORDS (IN RED)		(11) TO STATION B
								NORTHINGS (N)	EASTING (E)	
								1014614.799	759108.413	
12 29	04"	228 51 31	344.018	-226.336		-259.076		1014388.463	758849.337	
2 12 25		226 39 06	331.642	-227.650		-241.168		1014160.813	758608.169	
8 51 31								1014179.231	758806.912	
2 36 15			213					+0.027	+0.027	
1 27 46	-02"	191 27 44	213.490	-209.232		-42.425		1014179.258	758806.939	PEG 1
8 12 50			412					1014026.774	758680.450	
9 40 36	-04"	219 40 32	198.080	-152.457		-126.462		1014026.826	758680.502	BMK 600
9								1014026.267	758763.368	
50 40 30			494					+0.062	+0.062	
0 21 06	-05"	90 21 01	82.920	-0.507		82.918		1014026.329	758763.431	601
70								1013738.092	758774.759	
57 23 12			783					+0.098	+0.100	
7 44 18	-07"	177 44 11	288.400	-288.175		11.391		1013738.190	758774.859	602
57								1013493.649	758791.268	
8 24 02			1028					+0.129	+0.131	
6 08 20	-09"	176 08 11	245.000	-244.443		16.509		1013493.778	758791.399	603
6								1013279.630	758871.603	
3 17 23			1256					+0.158	+0.160	
9 25 43	-11"	159 25 32	208.600	-214.019		80.336		1013279.788	758871.763	604

LAND SURVEYING DEPARTMENT, FEDERAL POLY, BIDA

State _____ Closing Error for _____ Station _____ Surveyor _____ Date _____

of _____ Town _____ Bearing (True or Colony) _____ Computer _____ Date _____

(2) Back Bearing Observed Angle Forward Bearing	(3) Com to Bearing	(4) Corrected Bearing	(5) TRUE HORIZ DISTANCE	(6) DN	(7) Arith Sum	(8) DE	(9) Arith Sum	(10) UNCORRECTED CO-ORDS CORRECTION CO-CORDS (IN RED)		(11) TO STATION B
								NORTHINGS (N)	EASTING (E)	
39								1011339.533	759679.825	
71 47 37			3314					0.416	+0.422	
50 50 38	-26"	150 50 12	177.100	-154.650		86.301		1011389.949	759680.247	612
30								1011323.658	759839.284	
1 36 36			3486					+0.438	+0.444	
2 29 14	-27"	112 26 47	172.530	-65.875		159.459		1011324.096	759839.728	613
2								1011088.837	759868.243	
40 31 25			3723					0.468	+0.474	
2 58 39	-29"	172 58 10	236.600	-234.821		28.960		1011089.305	759868.717	PEG 2
2								1010785.034	759719.525	
3 06 50			4061					+0.510	+0.517	
6 05 27	-31"	206 04 58	338.250	-203.803		-148.718		1010785.544	759720.042	PEG 3
26								1010540.561	759642.716	
1 21 36			4318					+0.542	+0.550	
7 27 05	-33"	197 26 32	256.250	-244.468		-76.809		1010541.109	759643.206	PEG 4
7								1010447.681	759404.236	
31 16 40			4573					+0.575	+0.582	
48 43 45	-35"	248 43 10	255.930	-92.886		-238.479		1010448.286	759404.818	PEG 5
58								1010317.402	759297.137	
50 42 14			4742.					+0.596	+0.604	
9 25 59	-37"	219 25 22	168.650	-130.279		-107.099		1010317.998	759297.741	PEG 6

LAND SURVEYING DEPARTMENT, FEDERAL POLY, BIDA

PAGE 5

State NIGER Closing Error for 29 Station 53" Surveyor _____

Date 27-30/5/98

Town NAKOGI Bearing (True or Colony) _____ Computer _____

Date 30/6/98

(2) Back Bearing Observed Angle Forward Bearing	(3) Cor to Bearing	(4) Corrected Bearing	(5) TRUE HORIZ DISTANCE	(6) DN	(7) Arith Sum	(8) DE	(9) Arith Sum	(10) UNCORRECTED CO-ORDS CORRECTION CO-CORDS (IN RED)		(11) TO STATION B
								NORTHINGS (N)	EASTING (E)	
54								1009525.645	758501.072	
3 09 45			6105.06					+0.761	+0.777	
27 51 35	-51"	327 50 44	156.650	132.622		-83.370		1009526.412	758501.849	615
47										
9 38 43										
27 30 18	-53"	327 29 25	284.106	239.586		-152.691		1009765.998	758349.158	616
				ACCURACY =		1/5590	=	1/6,000		

LAND SURVEYING DEPARTMENT, FEDERAL POLY, BIDA

State _____ Closing Error for _____ Station _____ Surveyor _____
 Town _____ Bearing (True or Colony) _____ Computer _____

Date _____
 Date _____

(2) Back Bearing Served Angle Forward Bearing	(3) Com to Bearing	(4) Corrected Bearing	(5) TRUE HORIZ DISTANCE	(6) DN	(7) Arith Sum	(8) DE	(9) Arith Sum	(10) UNCORRECTED CO-ORDS CORRECTION CO-CORDS (IN RED)		(11) TO STATION B
								NORTHINGS (N)	EASTING (E)	
								1011725.088	755643.762	
9 57 20			4342					-0.157	-0.479	
8 38 05	+19"	328 38 24	393.100	335.674		-204.575		1011724.931	755643.283	629
								1012059.520	755439.839	
9 59 12			4734					-0.171	-0.523	
8 37 17	+20"	328 37 37	391.700	334.432		-203.922		1012059.349	755439.316	630
								1012394.832	755235.439	
30 00 24			5126					-0.185	-0.566	
28 37 41	+22"	328 38 03	392.700	335.311		-204.401		1012394.647	755234.873	631
								1012597.995	755442.870	
56 57 40			5417					-0.196	-0.598	
5 35 21	+23"	45 35 44	290.350	203.163		207.431		1012597.799	755442.272	632
								1012875.163	755731.276	
0 32 32			5817					-0.210	-0.642	
6 07 53	+25"	46 08 18	400.000	277.168		288.406		1012874.953	755730.634	633
								1013031.077	755927.213	
5 21 03			6067					-0.219	-0.670	
1 28 56	+26"	51 29 22	250.400	155.914		195.936		1013030.858	755926.543	634
								1013096.933	756081.549	
5 24 06			6235					-0.225	-0.688	
6 53 02	+28"	66 53 30	167.800	65.857		154.336		1013096.708	756080.861	635

LAND SURVEYING DEPARTMENT, FEDERAL POLY, BIDA

State _____ Closing Error for _____ Station _____ Surveyor _____ Date _____
 Town _____ Bearing (True or Colony) _____ Computer _____ Date _____

(2) Observed Angle and Bearing	(3) Corr to Bearing	(4) Corrected Bearing	(5) TRUE HORIZ DISTANCE	(6) DN	(7) Arith Sum	(8) DE	(9) Arith Sum	(10) UNCORRECTED CO-ORDS CORRECTION CO-CORDS (IN RED)		(11) TO STATION B
								NORTHINGS (N)	EASTING (E)	
46 46			8867					1014087.042	758503.332	
44 18	+39"	66 44 57	398.500	157.311		366.136		1014086.722	758502.358	643
15 10			8995.79					1014161.138	758609.162	
59 28	+41"	55 00 09	129.190	74.096		105.829		-0.325	-0.993	
38 56								1014160.813	758608.169	GPS
	+42"	46 39 06	331.642	227.650		241.168		1014388.463	758849.337	GPS

Accuracy = $\frac{1}{8609.795}$
 $\approx \frac{1}{9,000}$