

A COMPUTERIZED APPROACH TO TIME SERIES ANALYSIS OF CRUDE
OIL EXPORT
(A CASE STUDY OF NNPC LAGOS)

BY

DAVID, BABATUNDE

REG NO: PGD/MCS/158/96

A Project Submitted to Department of Mathematics and
Computer Science, School of Science and Science Education

In partial fulfilment of the requirements for the award of
POST GRADUATE DIPLOMA in COMPUTER SCIENCE

FEDERAL UNIVERSITY OF TECHNOLOGY,
MINNA, NIGER STATE, NIGERIA

MARCH, 1998

D E D I C A T I O N

**TO MY LATE FATHER
MR. OPEYOKUN DAVID**

A B S T R A C T

Time series analysis is a tool required for the proper understanding of the behaviour of series over time. It is in cognizance of this fact that this tool is applied for the proper understanding of the behaviour of crude oil export over a Five (5) year period.

Attempt is made to understand the trend and seasonal behaviour. The result of the trend analysis reflects an increasing trend in crude oil export is typically highest in December and lowest in February.

The estimation of trend and seasonal effects are combined to yield the forecasting model for crude oil export.

A C K N O W L E D G E M E N T

I give the greatest thanks to Almighty God for seeing me through the program. I'm very grateful to my project supervisor, MR. L.N. EZEAKO for his useful suggestions that translated this work into huge success.

I'm also grateful to the Head of Department of Maths and Computer Science in the person of Prof. K.R. Adeboye and all lecturers in the Department of Maths and Computer Science, some of whom are Prince Badmus (The co-ordinator), Dr. S.I. Reju, Dr. Y.M. Aiyesimi, and Mr Wale Israel, I'm equally grateful to the following Mr. Ajayi, Mr Okoro, Mr Bolarinwa Mr. and Mrs Omolohunna, Mr. Gbenga for their encouragement and support.

C E R T I F I C A T I O N

We, the undersigned certify that this work was carried out by MR. BABATUNDE DAVID, in the Department of Maths and Computer Science, Federal University of Technology, Minna, Niger State.

.....

SUPERVISOR

MR L.N. EZEAKO

.....

DATE

.....

HEAD OF DEPARTMENT

PROF. K.R. ADEBOYE

.....

DATE

.....

EXTERNAL EXAMINER

.....

DATE

T A B L E O F C O N T E N T S

| CONTENTS | PAGES |
|---|-------|
| TITLE..... | i |
| DEDICATION..... | ii |
| ABSTRACT..... | iii |
| ACKNOWLEDGEMENT..... | iv |
| CERTIFICATION..... | v |
| TABLE OF CONTENTS..... | vi |
| CHAPTER 1 : GENERAL INTRODUCTION | |
| 1.1: INTRODUCTION..... | 1 |
| 1.2: HISTORICAL BACKGROUND OF NNPC..... | 2 |
| 1.3: SCOPE AND LIMITATIONS..... | 4 |
| 1.4: AIMS AND OBJECTIVES..... | 4 |
| CHAPTER 2 : LITERATURE REVIEW..... | |
| 2.1: TIME SERIES ANALYSIS..... | 7 |
| 2.2: RELEVANCE OF COMPUTER APPLICATION..... | 10 |
| CHAPTER 3 : PROGRAM DESIGN | |
| 3.1: INPUT DESCRIPTION..... | 11 |
| 3.2: ALGORITHM REPRESENTATION..... | 11 |
| 3.2: PROGRAM DESCRIPTION..... | 26 |
| CHAPTER 4 : PROGRAM IMPLEMENTATION | |
| 4.1 : OUTPUT EXPECTED RESULTS..... | 28 |
| 4.2: INTERPRETATION OF RESULTS..... | 28 |
| 4.3: CUSTOMIZATION OF PROGRAM..... | 31 |

| CONTENTS | PAGES |
|--|--------------|
| CHAPTER 5 : CONCLUSION AND RECOMMENDATION | |
| 5.1: CONCLUSION..... | 32 |
| 5.2: RECOMMENDATION..... | 33 |
| BIBLIOGRAPHY..... | 34 |
| APPENDICES | |
| PROGRAM LISTING | 35 |
| PROGRAM OUTPUT..... | 38 |

CHAPTER ONE**GENERAL INTRODUCTION****1.1 Introduction**

Trading according to WEBSTER'S NEW WORLD'S SECOND EDITION DICTIONARY is "The buying and selling of commodities".

It is very essential therefore to state that trading involves only the tangible but also the intangibles. i.e. services.

It is pertinent to state that the core factor undertaking trading or business activities generally is exchange. Trading therefore can be rightly defined as the exchange of valuable goods and services between or among individuals, organisations or even nations. It may be exchange of goods for goods ie trade by barter, of using currency of the individual or organisations concerned. This is simply called domestic trade, but where the exchange involves two or more countries it becomes International Trade, International trade itself emanated from the fact understanding that no individual nation can produce all the goods and services that will satisfy her citizens, hence, the application of the "Theory of comparative advantage" This theory states that each nation should concentrate on the manufacturing of those goods and services it can produce at a cheaper rate and export same to those countries that do not have while importing those goods and services that other countries have a comparative advantage over her.

1.2 The Historical Background of N.N.P.C

The Nigerian National Petroleum corporation, otherwise known as N.N.P.C is a commercial, integrated, International Oil Company that engages in exploration, production processing, transportation and marketing of crude oil, gas their products and derivatives. The corporation is oriented towards efficiency profitability and financial autonomy in its operations while seeking to maintain its leadership role in Nigeria's long - term growth and economic development through the start up and fostering of new gas and petroleum based industries.

The N.N.P.C was established in 1977 by the N.N.P.C ACT of No 33 of that year through the merger of the Nigerian National Oil Company (N.N.O.C) whose functions were mainly operational and the then Federal Ministry of Petroleum Resources which performed regulatory functions. The two bodies were merged to create a more virile oil agency and optimise human and infrastructural resources available to government. The NNPC therefore performed both operational as well as regulatory functions and it was divided into eight division to carry out those functions effectively.

1.2.1 The history of crude oil marketing in Nigeria

Oil exploration began in Nigeria in 1908 although the documentation of the occurrence of minerals was reported some five years earlier in 1903. The exploration efforts were punctuated by the two world wars but eventually yielded results with the discovery of oil in OLOIBIRI in 1956 by SHELL-BP production increased from mere 5,000 barrels per day (b/d) in

1957 to 17,000 (b/d) by independence in 1960 and leap frogged to 450,000 (b/d) by 1966. Although this upward trend was slowed by the civil war, by 1970 daily production had reached 1 million barrel. A peak production level of 2.4 million barrels per day was achieved during the second quarter of 1979.

Production had fallen since then to the current 1 billion (b/d) both on technical grounds and adherence to OPEC quota brought about by the need to control production to support prices in a globally over supplied market.

The first exportation of oil from Nigeria occurred in 1958. As most of the multinational oil companies operating in the had 100% equity in their operations uptil 1973, there was no active government participation in the marketing of crude oil till the prior to 1973, all Nigeria crude oil was marketed by the oil producing companies through their integrated system using transfer prices.

From a regularity and largely passive role, limited to the collection of royalties and other dives offered by the oil companies, the government gradually become actively involved in the operations of industry. This change came about with the establishment of the Nigeria National Oil Corporation (NNOC) in 1971, as an integrated oil company to strengthen official control in the industry. This national desire for greater control in the oil industry becomes increasingly crucial to economic growth and development was further given a big boost when the country joined Organisation of Petroleum Exporting Countries (OPEC) whose Resolution XVI, Article 90 of 1968 enjoined all member states to

acquire participating interest in the operations of the oil companies in their countries.

OPEC eventually prescribed a time table that required each member country to have acquired 51 percent participatory interest by 1982. This collective aim was rightly in line with the government teaching that some of its aims and objectives for rapid industrial and commercial development would be enhanced, if it had more control in running of the oil industry.

1.3 Scope and Limitation

The scope of this project will cover only five years data by the department of Petroleum Resources of the Nigeria National Petroleum Corporation (NNPC) Lagos, and the data is limited to only crude oil export. The period under consideration is 1989 to 1993 inclusive. The data are collected on monthly basis, for the five years. I have a total of sixty (60) observations to work with.

1.4 Aims and Objectives

To develop a computer program that will carry out time series analysis, i.e estimate the trend line, the seasonal index and hence forecast.

CHAPTER TWO**LITERATURE REVIEW****2.0 Literature Review**

A lot of researches have discussed the export of crude oil in Nigeria. Some of these will be discussed in this chapter.

The Honourable Minister of Petroleum Resources, Dr. Rilwanu Lukman in an article the Nigeria Petroleum industry in 1988 in National Concord of Saturday, November 29, 1988 says that

"The world oil market continued to deteriorate as a result of weakening oil demand in an environment of over-supply of crude oil. As a result, prices have dropped sharply. The market was especially characterised by exceptional stock build-up, speculative activity following a 5% cut in production proposed by non-OPEC oil producing countries, over production by some members of OPEC and non-OPEC and short-term influence of seasonal factors"

The Honourable Minister of Petroleum Resources on Monday, October 10, 1989 in a seminar delivered at Obafemi Awolowo University, Ile-Ife on the topic: Future prospects of the world energy market and the role of OPEC, says that oil has thus become the most dominant energy market. Movements in oil prices have generally affected overall energy development and national economic growth and stability in the energy market is, therefore crucial for global economic growth and development. Both OPEC and non-OPEC producers have a significant role to play in order to achieve the stability let.

The OPEC chief scribe, in a paper presented at an International Conference of the Association for Energy Economic titled "The Global Energy Transition", with emphasis on the last five years of the century, had in Budapest, Hungary, recently

identified six factors that will continue to affect crude oil output globally.

According to him, regionalisation, environmental issue and technology are major factors that would influence the level of oil production before the end of this century.

The Secretary General of the Organisation of Petroleum Exporting Countries (OPEC) Dr. Rilwanu Lukmanu, said

"Up to the end of the 1980s, the Former Soviet Union (FSU) was the worlds leading oil product, it's dissolution however revealed an oil industry in a state of disarray, characterised by obsolete technology, high inefficiency and poor investment"

He also said that the issue of pricing is complicated by the fact that in the short to medium term, it depends up more than just economic fundamentals, stressing that in these days of highly computerized system, spot and future oil markets play a disproportionate role in determining the price of oil in the world market.

Dr. I.M. John, FMSCHS, FPIN, Group Managing Director in his article "Export - Oriented Refinery and The Export Processing Zone" says it is now a common knowledge that most petroleum exporting countries already have some term of export refining arrangement. Some countries own refineries abroad where their crude oil is processed while others refine in their own countries for export markets. The former definitely has the advantage of proximity to the target but tackles some of the developmental effects associated with the total siting of industries.

Tajudeen Adigun, Energy correspondent in an "Crude oil

prices firm up" in the Guardian, of Friday June, 28, 1996 said that oil traders has expected the decision of the 10th ministerial conference of OPEC to jack up the group's output to 25.5 million barrels a day to trigger a dangerous downward price spiral.

Chief Anthony Ani, The Minister of Finance in a paper titled "Nigerian economy: The way forward" at the opening of the third Nigeria economic summit in Abuja on 18th September, 1996, said that the present system where about 87 percent of the Nigeria crude oil is exported daily is not satisfactory.

Nigeria he said, must within the next five years either build or allow foreign investors to invest in export refineries so that substantial percentage of its crude oil is processed in Nigeria for export.

The Minister of Petroleum Resources, Chief Dan Etete in a write up "America energies largest importer of Nigerian's crude oil in Daily Sketch of 16th September, 1996 said that the growth of crude oil exports to the USA was traced to Nigerian National Petroleum Corporation (NNPC) marketing strategy of refining more of Nigeria's crude oil in offshore refineries as a result of declining performance of local refineries and high cost of maintaining them.

2.1 Time series analysis

A time series is a set of observations taken at specified times, usually at equal intervals. Time series could be defined as a sequence of measurements of numerical quantity made at successive periods of time, the time may be days , weeks months

or years. The knowledge of time series is of great importance to the management of NNPC as most of the data we have to deal with are time series data.

These data include monthly and yearly record of crude oil export in Nigeria. By considering the past records, the management of NNPC can make forecast and projection about the future export of crude oil, though there are restrictions by OPEC, hence forecasting has to be made for a few months say one to six months because of the rapid changes in OPEC regulations.

2.1.1 Classification of Time Series Movement

Characteristic movements of time series may be classified into four main types, often called components of a time series; there are long term or secular movements. The last two movements shall be discussed in this project.

A. Seasonal Movement

Seasonal movements or seasonal variations refer to the identical, or almost identical, patterns which a time series appears to follow during corresponding months of successive years, such movements are due to recurring events which take place annually, as for instance the sudden increase of department sales before christmas.

Although seasonal movements in general refer to annual periodicity in business or economic theory, the ideas involved can be extended to include periodicity over any intervals of time such as daily, hourly, weekly, etc, depending on the type of data available.

B. Irregular or Random Movements

These refer to the sporadic motions of time series due to chance events such as floods, strikes, elections etc. Although it is ordinarily assumed that such events produces variation lasting only a short - time. It is conceivable that they may be so intense as to result in new cyclical or other movements.

2.1.2 Trend Analysis

Trend refers to the general direction in which the time plot appears to be moving. A time series is said to contain or exhibit trend if the mean of the series changes systematically with time, the systematic changes could be linear, exponential, quadratic or any other function we denote by it the amount of trend in the series X_t . But in this project linear function will be used in performing the analysis. Since the series contain trend, we can now estimate the parameter a and b by using the first order polynomial i.e $Y = A + BX$.

In this series the Time variable (X) can be coded such that $X=0$ to ease calculation , here our interest in crude oil export is to check may be there is relationship between the time coded and the crude oil export recorded over the years and to know the amount of increase or decrease.

Later a program will be developed to compute the necessary trend equation. Therefore the required least square equation is

$$Y = A+BX , \quad \text{where}$$

$$Y = \text{Trend value}$$

A = Y intercept or computed value of Y where $X = 0$

B = slope of trend line

X = Time

In order to determine the values of the constant A and B a program will be developed later.

2.2.2 Relevance of Computer Application

The series analysis is a phenomenon that involves a lot of computation. In the light of this, a great deal of time and improved accuracy can be gained from computerization of the process. Trend Analysis, seasonal analysis and forecasting can be done with ease within few minutes by the computer.

CHAPTER THREE**PROGRAM DESIGN****3.1 Input Description**

This is the stage where the total explanation of the program is made. Input to the program are monthly trends values and seasonal index numbers. The trend values cover a period of five years and are supplied to the program.

3.2 Algorithm Representation

In order to make use of computer solution to a problem, it is necessary to divide steps to be taken by the computer. This involves working out the algorithm for the problem.

Algorithm thus, exists in different forms (e.g pseudo codes, N-S diagram etc) of presenting algorithms, flowcharts is made use of in this work as it provides good visual representation and easy appreciation of the logic of the algorithm it is representing.

FLOWCHART

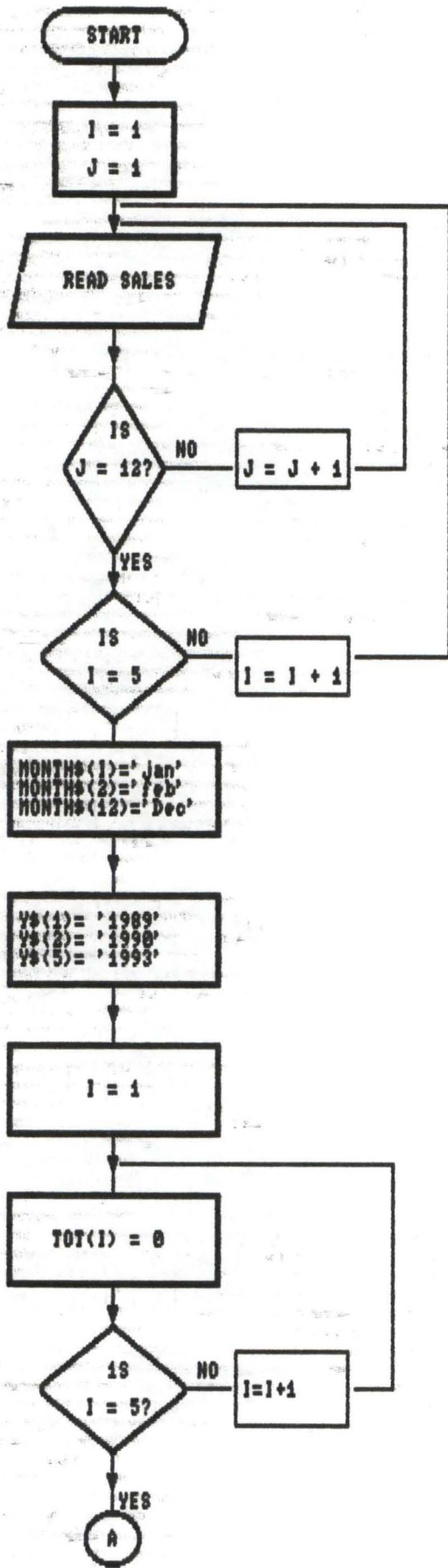

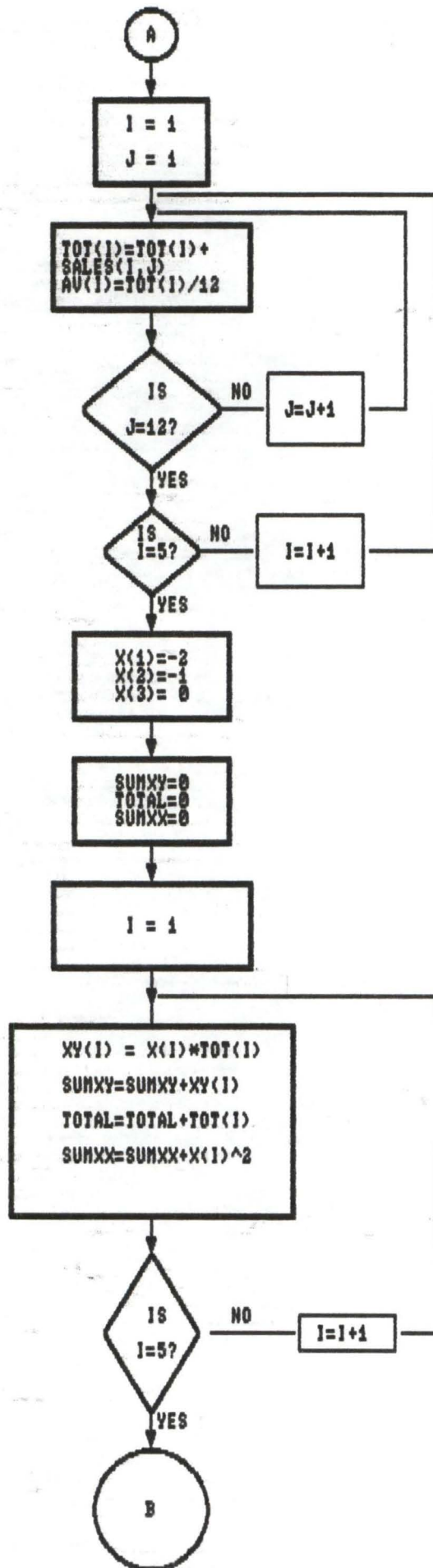

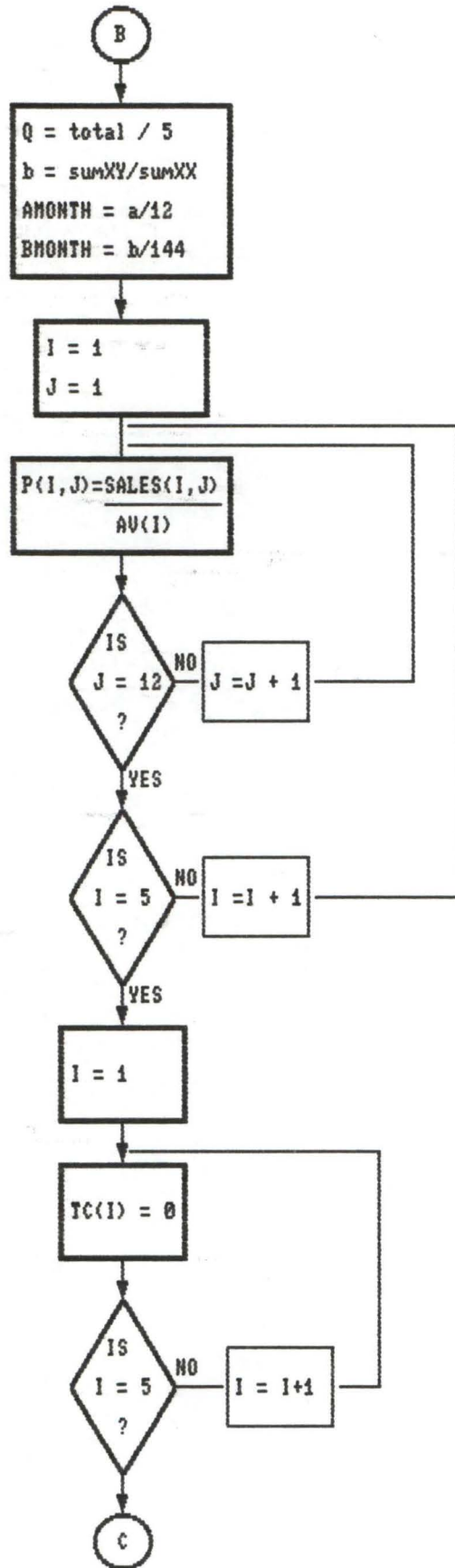

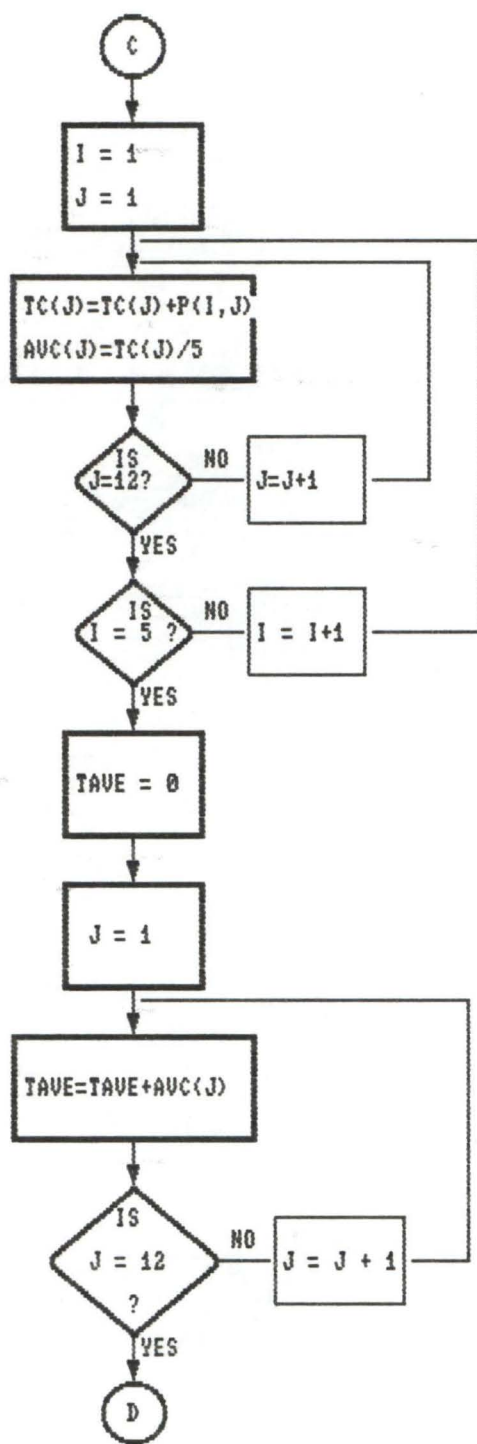

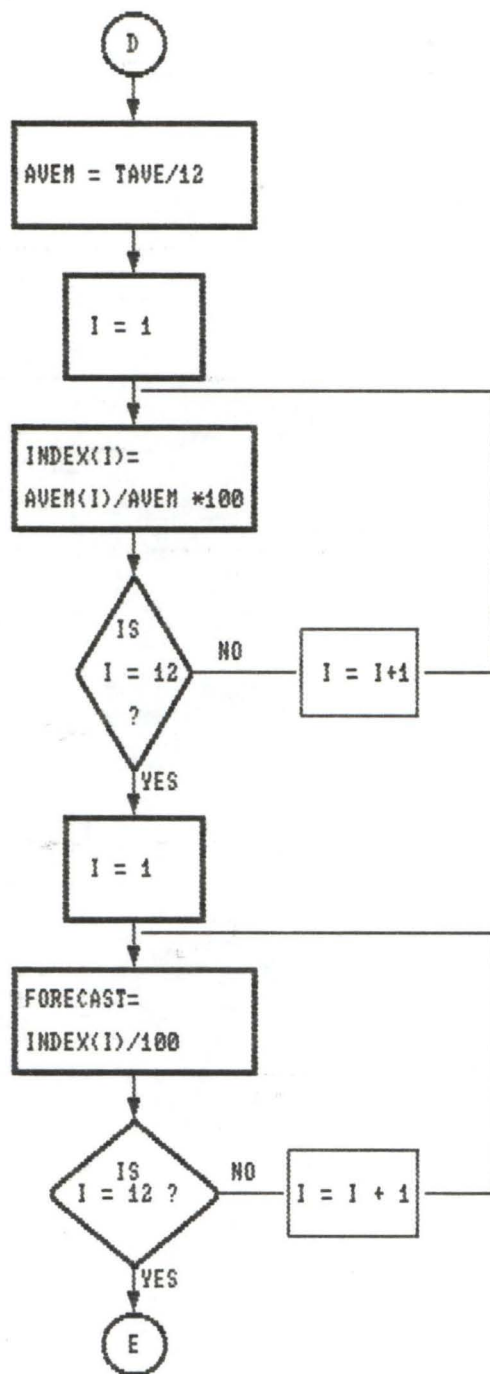

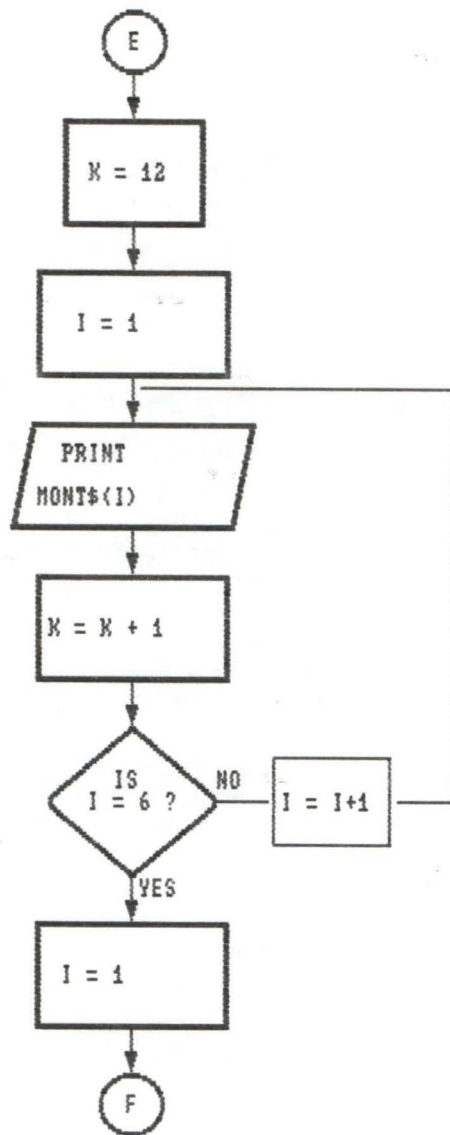

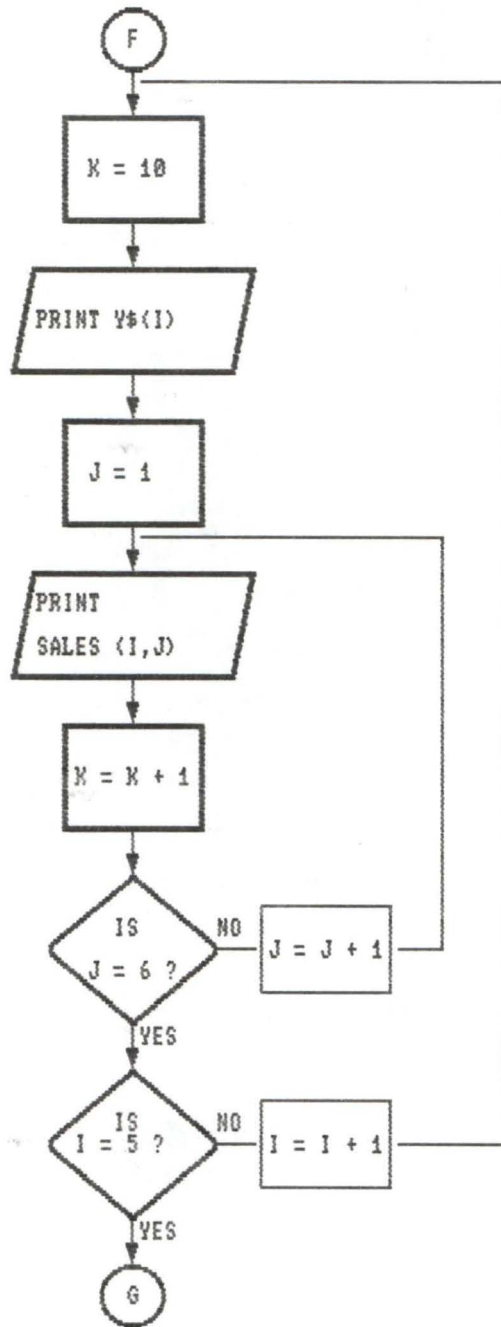

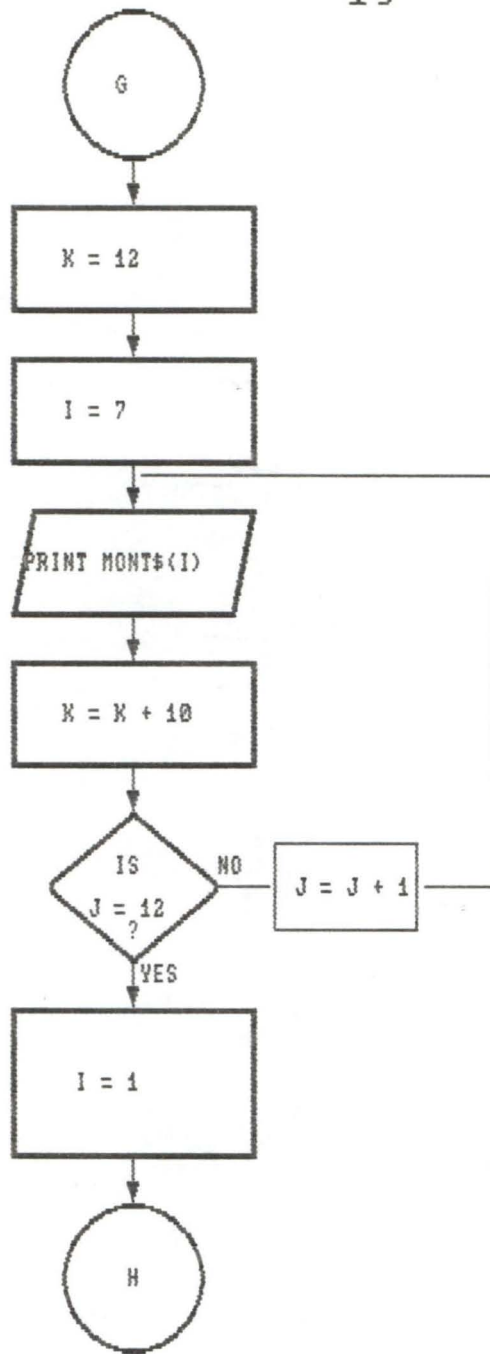

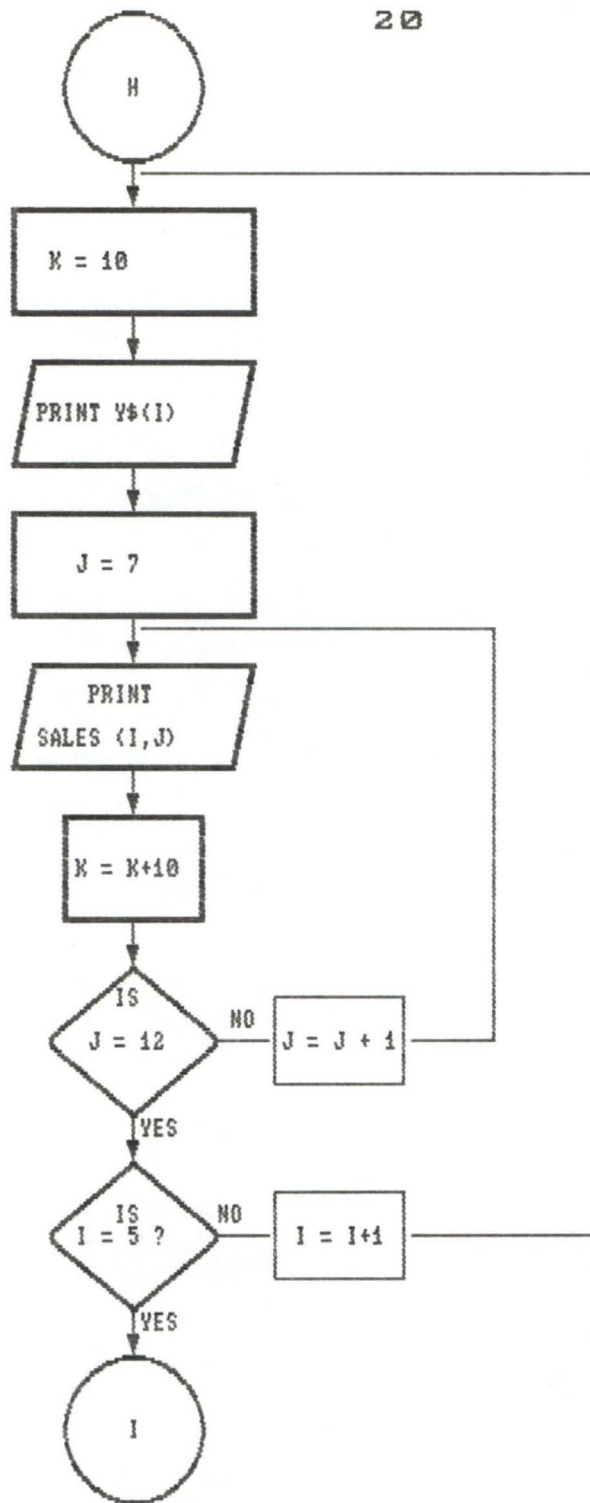

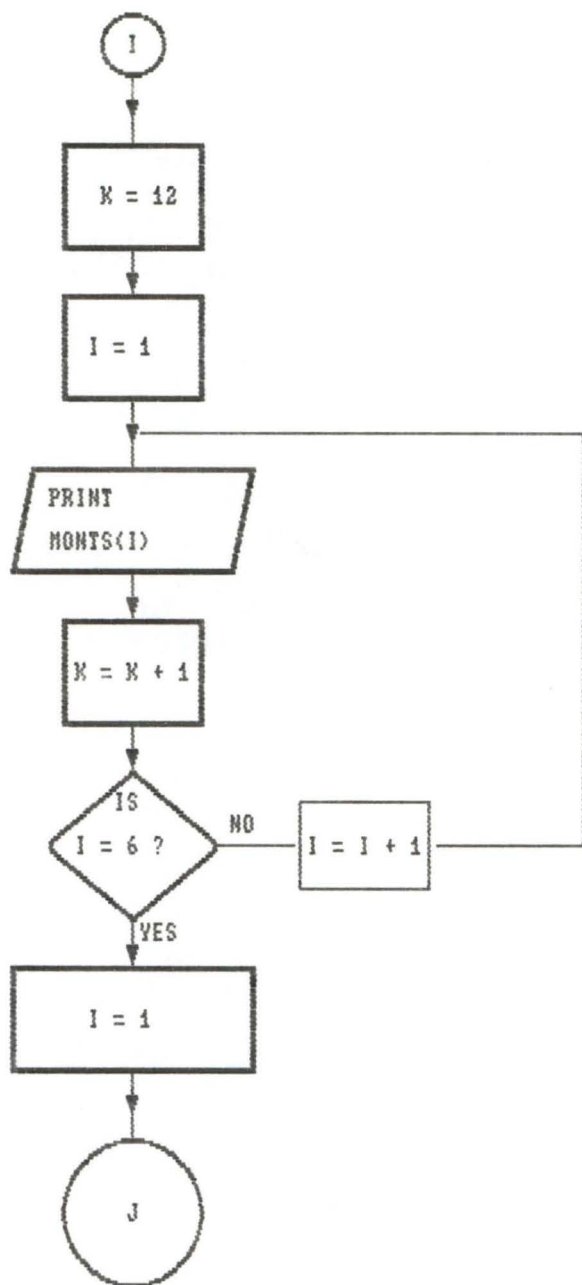

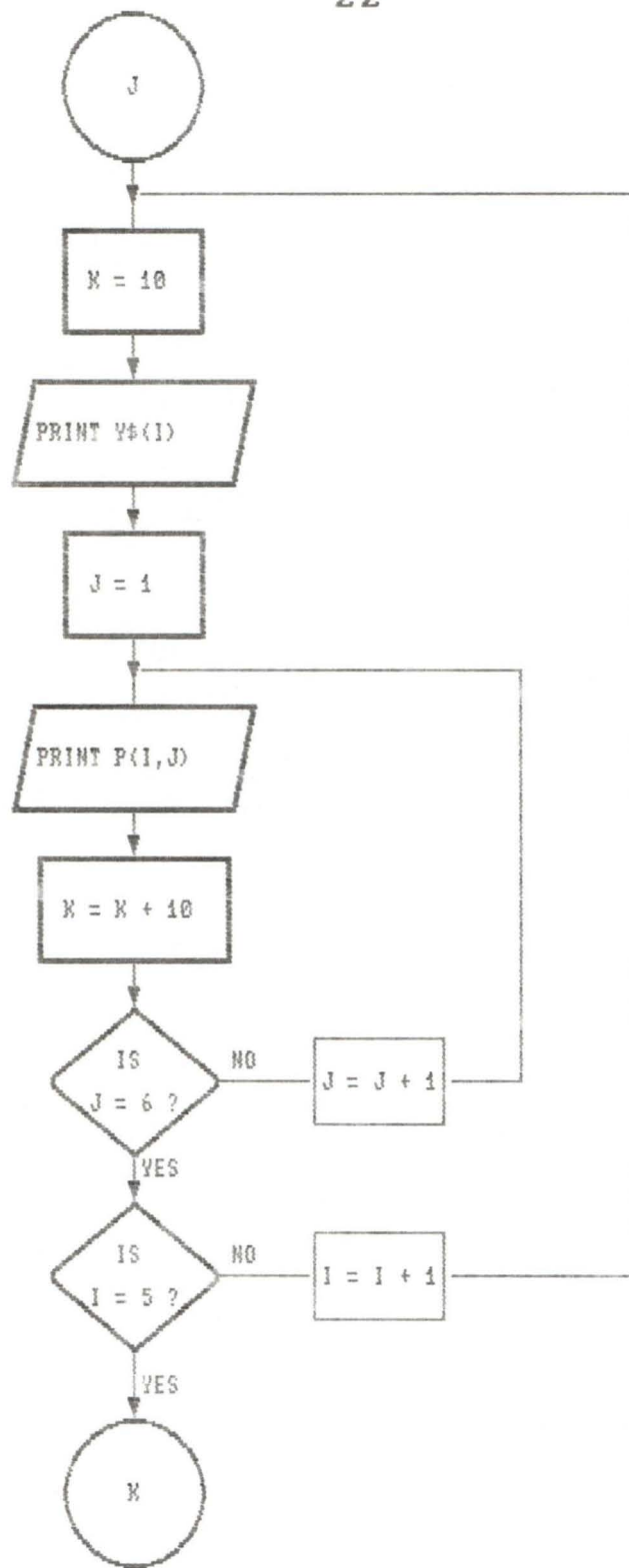

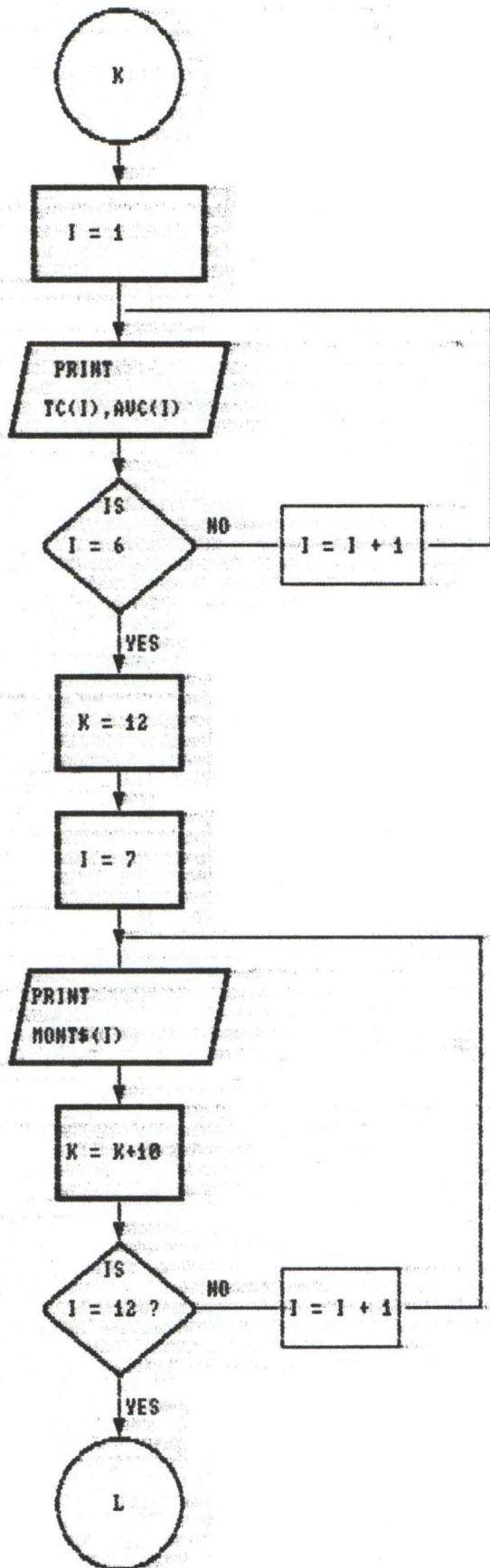

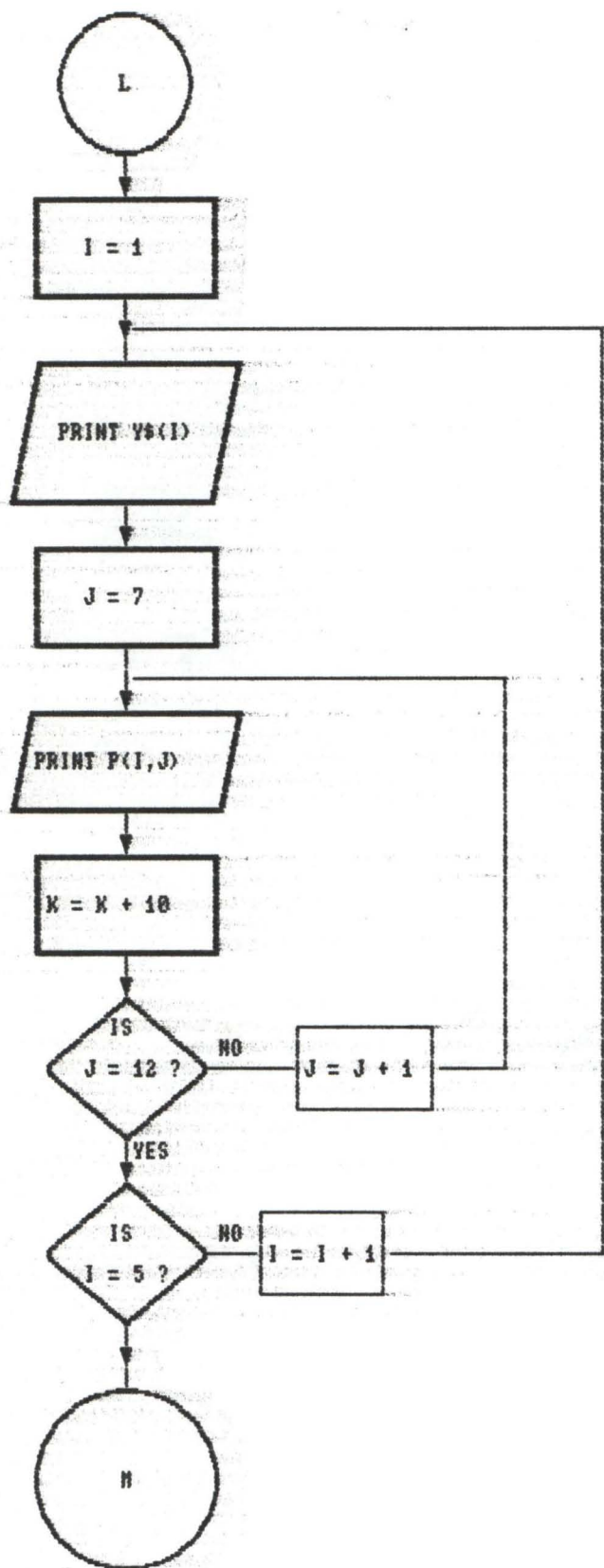

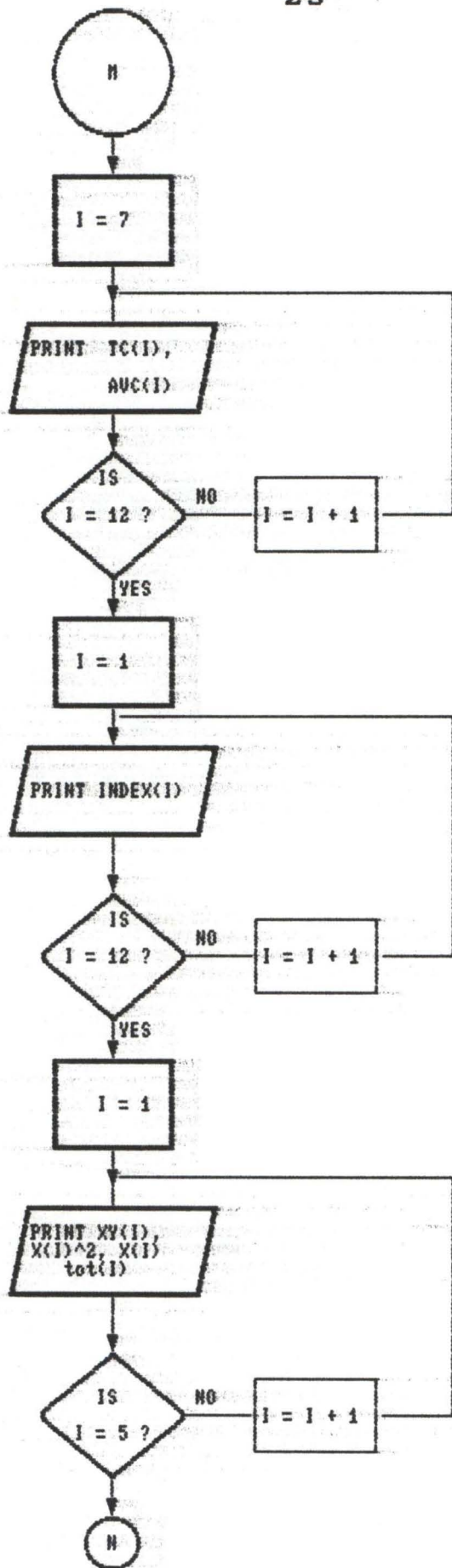

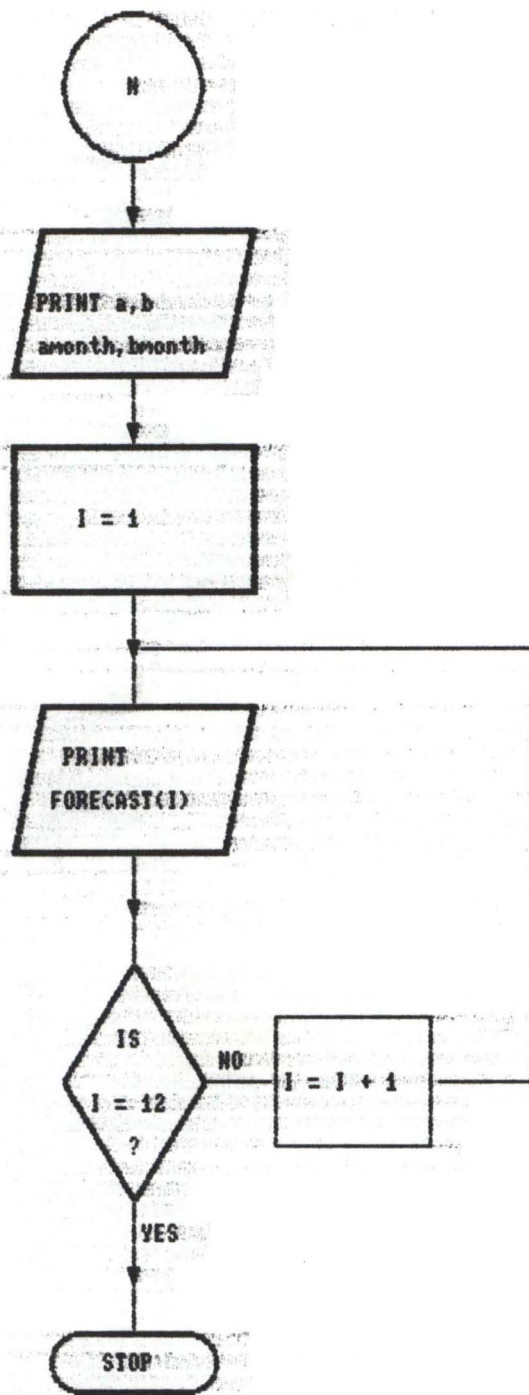

3.3 Program Description

The writing of a program or flowchart in a language of one's choice is next step - Q-basic is the language of choice in this project. This section aims at describing in steps what the various segments of the program accomplish and is all about.

- Step 1: Ln (20-60) input the data values
- Step 2: Ln (70-140) assign strings to 12 months and 5 years.
- Step 3: Ln (150-240) compute total and average monthly sales for each of the 5 years.
- Step 4: Ln 250 assign coded values to the independent variable X.
- Step 5: Ln (260-320) compute the summation of XY and X².
- Step 6: Ln (330-340) compute the slopes and intercept of the annual and monthly equation.
- Step 7: Ln (350-400) express as a percentage of average for the year and sales values i.e compute table of 90.
- Step 8: Ln (410-490) compute the total and mean for each column of table of 90's.
- Step 9: Ln (500-570) compute the required index.
- Step 10: Ln (580-610) compute forecast.
- Step 11: Ln (620-930) print inputted sales values.
- Step 12: Ln (940-1320) print table of %'s.
- Step 13: Ln (1330-1390) print seasonal index no's.
- Step 14: Ln (1400-1480) print table of trend analysis.
- Step 15: Ln (1490-1580) print slopes and intercepts for annual and monthly trend equations.
- Step 16: Ln (1590-1620) print the forecast.
- Step 17: Ln (1630-1670) present the sales values (data).

Step 18: Ln 1680 end of the program.

CHAPTER FOUR
PROGRAM IMPLEMENTATION

4.1 Output Expected

The program is expected to output the original values, table of percentage (Computed in the course of computing the index), the seasonal index and forecasts for a 12 month period i.e January 1994 - December 1994.

It is also expected to output details of trend fitting, parameter estimates of both the annual trend equation and corresponding monthly equation. Note that the monthly trend equation is derived from the annual equation by dividing the intercept and slope of the annual trend equation by 12 and 144 respectively.

The origin of the resulting monthly equation is the beginning of July 1991, and since figure for any month is assumed to coincide with the middle of the month, the origin is accordingly shifted to middle of July 1991 to reflect the convention. The equation is then used to estimate monthly trend values which are later combined with respective seasonal index figures to obtain the time series forecasts.

4.2 Interpretation of Results

The computed table of percentages presents the specific seasonal variations, specific seasonal implies the effect of a season in a particular year.

The generalised expression of these variations is called the typical seasonal, the typical seasonal variation is therefore the

average of specific seasonal for a number of years. The typical seasonal variation is what the seasonal index computes.

Since our interest mainly lies on the typical seasonal rather than specific seasonal variation, only the seasonal index seasonal figures shall be interpreted.

4.2.1 Interpretation of Seasonal Index

96.32% for January implies that the crude oil export for January is 3.68% less than average monthly export. 90.35% February implies that export for February is 9.65% less than average monthly export. These are condensed into the table given below.

| Months | Index | Interpretation | | | |
|-----------|--------|----------------|---|-----------------|--------|
| January | 96.32 | 3.68 % | < | Average Monthly | Export |
| February | 90.35 | 9.65 % | < | " | " |
| March | 101.59 | 1.59 % | > | " | " |
| April | 96.69 | 3.31 % | < | " | " |
| May | 98.99 | 1.01 % | < | " | " |
| June | 101.21 | 1.21 % | > | " | " |
| July | 97.22 | 2.88 % | < | " | " |
| August | 105.03 | 5.03 % | > | " | " |
| September | 103.68 | 3.68 % | > | " | " |
| October | 101.68 | 1.68 % | > | " | " |
| November | 97.53 | 2.47 % | < | " | " |
| December | 109.71 | 9.71 % | > | " | " |

4.2.2 Interpretation of the Annual Trend Equation

The annual trend equation developed is of the form.

$$Y = 614.578 + 10.152X$$

Origin : 1991

X unit : 1 year

The intercept of 614.578 represents the estimates of trend at the origin i.e when $X=0$, the slope of 10.152 represents increase in Y per unit increase in X i.e annual increment in crude oil export is 10.152 million barrels.

4.2.3 Interpretation of Monthly Equation

The monthly trend equation is of the form

$$Y = 51.215 + .071X$$

Origin : July 1991

X Unit : 1 month

The intercept of 51.215 represents estimates of trend at the origin. The slope implies a monthly increment of 0.071 million barrels in crude oil export. The forecast for a year period on monthly basis serve as an indicator of idea of future crude oil export in millions of barrels, such forecasts are not expected to exactly coincide with the actual figures to be realized. The aim of any modelling process is to minimize the difference between estimate value and the realized or true or actual value.

4.3 Customization of Program

This program is designed for monthly time series data covering period of five years. However, the program can be used for other period of time require some amendments.

Users can easily make use of this program by deleting the existing data and replacing them as required.

C H A P T E R F I V E
C O N C L U S I O N A N D R E C O M M E N D A T I O N

5.1 Conclusion

The annual and monthly trend equation suggest an upward trend in crude oil export. The annual equation suggests an annual increment of 614.58 millions barrels in crude oil export while the monthly equations suggests a monthly increment of 0.071 million barrels of crude oil export.

The implication of this upward trend is that NNPC should be prepared to cope with future demand for crude oil which according to the developed trend equations would be higher. The computed seasonal index reflects that crude oil export is lower than average monthly export in the months of January, February, April, May, July and November while it is higher for the other months of the year.

This information is vital to NNPC since such would provide a basis for production planning especially the monthly based planning.

The forecasts give an idea of what the export would be beyond the period covered by the data, such forecasts are a guide for production planning and control.

The forecasts are only useful if factors that determined the volume of crude oil export within the period covered by the data will continue to exhibit similar behaviour during period covered by the forecasts, few examples of such are cost of substitute to oil, OPEC policies on production quota, discovery of cheaper alternative to oil etc.

If for example OPEC cuts down Nigerian production quota as a matter of policy, the country will have no option than to abide. Costs of substitutes and discovery of viable alternatives can equally affects the demand for and hence crude oil export.

If any of these aforementioned cases occurs, the crude oil export may eventually be lower than anticipated by the time series model.e.g If the substitutes cost less

On the other hand, if for any reason one or more of the major world exporters of crude oil produces less , then there is tendency for Nigeria to export more than anticipated by the time series model.

5.2 Recommendations

I recommend that Time series analysis be carried out on price of crude oil per barrel, volume of local consumption of petrol, petroleum and price of oil products like kerosine, lubricating oil, bitument etc.

B I B L I O G R A P H Y

- (1) Francis, A. (1987). Business Mathematics & Statistics
Guerbsay Press Co. Ltd. Channel
Islands. 3rd Edition.
- (2) Kendall M. G. (1968). An Introduction to the Theory of
Statistics Oxford Publishing
(London). 4th Edition.
- (3) Murray R. S. (1972). Theory & Problems on Statistics
Mc Grawhill Int-Book Co. 1st
Edition.
- (4) Richard I. L. (1981). Statistics for Management: Longman
group Ltd. London 2nd Edition.
- (5) Roger, C. (1980). Quantitative Method for Bussiness
Students: Heinenmann Proffessionals
London. ELBS Edition.

```

DIM SALES(5, 12), P(5, 12), TC(12), AV(12), index(12), FORECAST(12), MONT$(12)
DIM avc(12)
FOR i = 1 TO 5
  FOR j = 1 TO 12
    READ SALES(i, j)
  NEXT j
NEXT i
MONT$(1) = "JAN": MONT$(2) = "FEB": MONT$(3) = "MAR": MONT$(4) = "APR":
MONT$(5) = "MAY": MONT$(6) = "JUNE": MONT$(7) = "JULY": MONT$(8) = "AUG":
MONT$(9) = "SEP": MONT$(10) = "OCT": MONT$(11) = "NOV": MONT$(12) = "DEC"
y$(1) = "1989": y$(2) = "1990": y$(3) = "1991": y$(4) = "1992":
y$(5) = "1993"
'TREND ANALYSIS
FOR i = 1 TO 5
  tot(i) = 0
NEXT i
FOR i = 1 TO 5
  FOR j = 1 TO 12
    tot(i) = tot(i) + SALES(i, j)
    AV(i) = tot(i) / 12
  NEXT j
NEXT i
x(1) = -2: x(2) = -1: x(3) = 0: x(4) = 1: x(5) = 2
sumxy = 0: total = 0: sumxx = 0
FOR i = 1 TO 5
  xy(i) = x(i) * tot(i)
  sumxy = sumxy + xy(i)
  total = total + tot(i)
  sumxx = sumxx + x(i) ^ 2
NEXT i
a = total / 5: b = sumxy / sumxx
amonth = a / 12: bmonth = b / 144
'SEASONAL ANALYSIS
FOR i = 1 TO 5
  FOR j = 1 TO 12
    P(i, j) = (SALES(i, j) / AV(i)) * 100
  NEXT j
NEXT i
FOR i = 1 TO 12
  TC(i) = 0
NEXT i
FOR i = 1 TO 5
  FOR j = 1 TO 12
    TC(j) = TC(j) + P(i, j)
  NEXT j
NEXT i
TAVE = 0
FOR j = 1 TO 12
  TAVE = TAVE + TC(j)
NEXT j
AVEM = TAVE / 12
FOR i = 1 TO 12
  index(i) = 100 * avc(i) / AVEM
NEXT i
'FORECASTING FOR JAN-DEC 1994
FOR i = 1 TO 12
  FORECAST(i) = ((amonth + .5 * bmonth) + bmonth * (i + 29)) * index(i)
NEXT i
/ 100

```

```

FORECAST(i) = ((amonth + .5 * bmonth) + bmonth * (i + 29)) * index(i) / 100
NEXT i
PRINT TAB(30); "OUTPUT"
PRINT TAB(30); "*****"
PRINT : PRINT
PRINT TAB(20); "TABLE OF SALES VALUES"
PRINT TAB(20); "*****"
K = 12
FOR i = 1 TO 6
PRINT TAB(K); MONT$(i);
K = K + 10
NEXT i
FOR i = 1 TO 5
K = 10
PRINT TAB(5); y$(i);
FOR j = 1 TO 6
PRINT TAB(K); SALES(i, j);
K = K + 10
NEXT j
NEXT i
PRINT : PRINT
K = 12
FOR i = 7 TO 12
PRINT TAB(K); MONT$(i);
K = K + 10
NEXT i
FOR i = 1 TO 5
K = 10
PRINT TAB(5); y$(i);
FOR j = 7 TO 12
PRINT TAB(K); SALES(i, j);
K = K + 10
NEXT j
NEXT i
PRINT : PRINT : PRINT
PRINT TAB(30); "table of %"
PRINT TAB(30); "*****"
K = 12
FOR i = 1 TO 6
PRINT TAB(K); MONT$(i);
K = K + 10
NEXT i
FOR i = 1 TO 5
K = 10
PRINT TAB(5); y$(i);
FOR j = 1 TO 6
PRINT TAB(K); P(i, j);
K = K + 10
NEXT j
NEXT i
PRINT TAB(5); "total"; TAB(10); TC(1); TAB(20); TC(2); TAB(30); TC(3);
PRINT TAB(40); TC(4); TAB(50); TC(5); TAB(60); TC(6)
PRINT TAB(5); "mean"; TAB(10); avc(1); TAB(20); avc(2); TAB(30); avc(3);

```

```

0 PRINT TAB(40); avc(4); TAB(50); avc(5); TAB(60); avc(6)
0 PRINT : PRINT : PRINT
0 K = 12
0 FOR i = 7 TO 12
0 PRINT TAB(K); MONT$(i);
0 K = K + 10
0 NEXT i
0 FOR i = 1 TO 5
0 K = 10
0 PRINT TAB(5); y$(i);
0 FOR j = 7 TO 12
0 PRINT TAB(K); P(i, j);
0 K = K + 10
0 NEXT j
0 NEXT i
0 PRINT TAB(5); "total"; TAB(10); TC(7); TAB(20); TC(8); TAB(30); TC(9);
0 PRINT TAB(40); TC(10); TAB(50); TC(11); TAB(60); TC(12)
0 PRINT TAB(5); "mean"; TAB(10); avc(7); TAB(20); avc(8); TAB(30); avc(9);
0 PRINT TAB(40); avc(10); TAB(50); avc(11); TAB(60); avc(12)
0 PRINT : PRINT : PRINT
0 PRINT TAB(33); "sesonal index"
0 PRINT TAB(33); "*****"
0 PRINT TAB(32); "month"; TAB(44); "index"
0 PRINT TAB(32); "-----"; TAB(44); "-----"
0 FOR i = 1 TO 12
0 PRINT TAB(32); MONT$(i); TAB(42); index(i)
0 NEXT i
0 PRINT : PRINT
10 PRINT TAB(13); "x"; TAB(30); "y"; TAB(44); "xy";
20 PRINT TAB(57); "x^2";
30 FOR i = 1 TO 5
40 PRINT TAB(12); x(i); TAB(28); tot(i); TAB(42); xy(i);
50 PRINT TAB(57); x(i) ^ 2;
60 NEXT i
70 PRINT TAB(11); "total"; TAB(28); total; TAB(42); sumxy; TAB(57); sumxx
80 PRINT : PRINT
90 PRINT "for the annual equation"
0 PRINT "intercept="; a
0 PRINT "slope="; b
0 PRINT : PRINT
10 PRINT "for the monthly equation"
0 PRINT "intercept="; amonth
0 PRINT "slope="; bmonth
0 PRINT : PRINT
0 PRINT TAB(30); "table of forecasts"
0 PRINT TAB(30); "*****"
0 FOR i = 1 TO 12
0 PRINT TAB(30); MONT$(i); TAB(40); FORECAST(i)
0 NEXT i
0 DATA 38.43,36.76,46.29,42.71,45.79,54.05,42.49,54.37,50.11,48.15,46.66,52.
0 DATA 56.38,50.87,55.70,54.41,53.81,50.75,50.48,54.73,56.45,59.17,57.67,60.
0 DATA 47.29,50.00,51.82,50.68,49.52,52.50,49.79,54.44,51.26,45.13,43.94,54.
0 DATA 54.13,44.54,52.61,49.16,53.94,49.85,51.54,52.23,54.86,55.86,49.55,58.
0 DATA 51.41,49.70,53.78,50.87,50.43,50.84,54.79,52.28,52.59,52.37,52.18,54.

```

OUTPUT

TABLE OF SALES VALUES

| | JAN | FEB | MAR | APR | MAY | JUNE |
|------|-------|-------|-------|-------|-------|-------|
| 1989 | 38.43 | 36.76 | 46.29 | 42.71 | 45.79 | 54.05 |
| 1990 | 56.38 | 50.87 | 55.7 | 54.41 | 53.81 | 50.75 |
| 1991 | 47.29 | 50 | 51.82 | 50.68 | 49.52 | 52.5 |
| 1992 | 54.13 | 44.54 | 52.61 | 49.16 | 53.94 | 49.85 |
| 1993 | 51.41 | 49.7 | 53.78 | 50.87 | 50.43 | 50.84 |
| | JULY | AUG | SEP | OCT | NOV | DEC |
| 1989 | 42.49 | 54.37 | 50.11 | 48.15 | 46.66 | 52.52 |
| 1990 | 50.48 | 54.73 | 56.45 | 59.17 | 57.67 | 60.31 |
| 1991 | 49.79 | 54.44 | 51.26 | 45.13 | 43.94 | 54.67 |
| 1992 | 51.54 | 52.23 | 54.86 | 55.86 | 49.55 | 58.4 |
| 1993 | 54.79 | 52.28 | 52.59 | 52.37 | 52.18 | 54.88 |

table of %

| | JAN | FEB | MAR | APR | MAY | JUNE |
|-------|----------|----------|----------|----------|----------|----------|
| 1989 | 82.59631 | 79.00703 | 99.48955 | 91.79517 | 98.41492 | 116.1679 |
| 1990 | 102.3958 | 92.38871 | 101.1608 | 98.81797 | 97.72826 | 92.17078 |
| 1991 | 94.41635 | 99.82697 | 103.4607 | 101.1846 | 98.86863 | 104.8183 |
| 1992 | 103.6526 | 85.2889 | 100.742 | 94.13567 | 103.2888 | 95.45693 |
| 1993 | 98.53063 | 95.25331 | 103.0729 | 97.49569 | 96.6524 | 97.43819 |
| total | 481.5918 | 451.765 | 507.926 | 483.4291 | 494.953 | 506.0521 |
| mean | 96.31836 | 90.35299 | 101.5852 | 96.68582 | 98.9906 | 101.2104 |

| | JULY | AUG | SEP | OCT | NOV | DEC |
|-------|----------|----------|----------|----------|----------|----------|
| 1989 | 91.32234 | 116.8556 | 107.6997 | 103.4872 | 100.2848 | 112.8795 |
| 1990 | 91.6804 | 99.39914 | 102.523 | 107.4629 | 104.7387 | 109.5334 |
| 1991 | 99.4077 | 108.6916 | 102.3426 | 90.10382 | 87.72794 | 109.1508 |
| 1992 | 98.69308 | 100.0144 | 105.0505 | 106.9654 | 94.88247 | 111.8292 |
| 1993 | 105.0086 | 100.198 | 100.7922 | 100.3705 | 100.0064 | 105.1811 |
| total | 486.1122 | 525.1588 | 518.408 | 508.3899 | 487.6403 | 548.574 |
| mean | 97.22243 | 105.0318 | 103.6816 | 101.678 | 97.52805 | 109.7148 |

sesonal index

 month index

JAN 96.31836
 FEB 90.35299
 MAR 101.5852
 APR 96.68582
 MAY 98.9906
 JINE 101.2104
 JULY 97.22243
 AUG 105.0318
 SEP 103.6816
 OCT 101.678
 NOV 97.52805
 DEC 109.7148

| x | y | xy | x ² |
|-------|---------|----------|----------------|
| -2 | 558.33 | -1116.66 | 4 |
| -1 | 660.73 | -660.73 | 1 |
| 0 | 601.04 | 0 | 0 |
| 1 | 626.67 | 626.67 | 1 |
| 2 | 626.12 | 1252.24 | 4 |
| total | 3072.89 | 101.5199 | 10 |

for the annual equation
 intercept = 614.578
 slope = 10.15199

for the monthly equation
 intercept = 51.21483
 slope = 7.049993E-02

table of forecasts

JAN 51.40037
 FEB 48.28064
 MAR 54.35425
 APR 51.80096
 MAY 53.10557
 JINE 54.36778
 JULY 52.29408
 AUG 56.56861
 SEP 55.91454
 OCT 54.90568
 NOV 52.7335
 DEC 59.40023