

**COMPUTERIZATION OF TELEVISION
TROUBLESHOOTING OPERATION**

**BY
OLADIMEJI, TESSY KOLAWOLE
PGD/MCS/97/271**

**A PROJECT SUBMITTED TO THE
DEPARTMENT OF MATHEMATICS AND
COMPUTER SCIENCE FEDERAL
UNIVERSITY OF TECHNOLOGY,
MINNA.**

DECEMBER, 1999.

TITLE PAGE

COMPUTERIZATION OF TELEVISION TROUBLESHOOTING OPERATION

**BY
OLADIMEJI, TESSY KOLAWOLE
PGD/MCS/97/271**

**A PROJECT SUBMITTED TO THE
DEPARTMENT OF MATHEMATICS AND
COMPUTER SCIENCE IN PARTIAL
FULFILLMENT OF THE REQUIREMENTS
FOR THE AWARD OF POST-GRADUATE
DIPLOMA IN COMPUTER SCIENCE OF THE
FEDERAL UNIVERSITY OF TECHNOLOGY,
MINNA.**

DECEMBER, 1999.

CERTIFICATION

We hereby certify that we have supervised, read and approved this project work which we have found to be adequate in scope and quality for the partial fulfilment of the award of a Post-Graduate Diploma in Computer Science of Federal University of Technology, Minna.

.....
Dr. Aiyesimi Y. M.
Project Supervisor

.....
Date

.....
Dr. Reju
Head of Department

.....
Date

.....
External Examiner

.....
Date

DEDICATION

This project work is dedicated to my sister Mrs. Amina Adamu and all those in similar condition waiting steadfastly in Almighty Allah to be bless with fruit of the womb.

ACKNOWLEDGEMENT

My profound gratitude goes to Almighty God for His infinite mercy and protection on me before, during and by His grace even after this project. I thank my parents for giving me this golden opportunity to acquire formal education and also for their financial and moral supports.

Similarly, I am very grateful to my able project supervisor, Dr. Yomi Aiyesimi for his support, advice and absolute co-operation. Mention should also be made of the able and competent Dean Professor Adeboye K.R., Head of Department Dr. Reju and hardworking Lecturers Prince Badmus, Mr. Ezeako L.N. and all other members of staff of maths/computer science dept, F.U.T., Minna, not mentioned.

Furthermore, I am grateful to my brothers especially Mr Abdul-lateef Femi Oladimeji of N.T.A. Minna who gave me most of the reference materials used in this project work, Alfa Majeed Sola Oladimeji, Alfa Mohammed Musbau Yakubu, Safiu Oladimeji and Abdul-Rafiu Abubakar Baro. Thanks to my sisters Mrs Risikat Shittu, Mrs Khadijat Aliyu, Miss Lateefat Abubakar.

Finally, my gratitude to my dear friends Abdul-Lateef Folrunso, Adesope (APMEU KAD), Mustapha Rufai, Mohammed Mustapha, Dauda Alfa, Olaolu Sangoyinka, Miss Mary Osiako, Hajia Bukola Omokeyin and Miss Saida Sanusi.

Last but not the least I am sincerely grateful to Mr. Samuel (APMEU KAD), Miss Veronica Ameh (Logicgate Minna), Mrs Yemisi who did the typing and proof reading. I wish them all success in all their future endeavours may Almighty God bless and reward you all (Amen).

ABSTRACT

This is a study on the “COMMPUTERIZATION OF TELEVISION TROUBLESHOOTING OPERATIONS”. It is meant to directly or indirectly takes over from the conventional or traditional methods of manual repairs that were based on assumption, trial and error, incidental discovery, set comparing, and remove - test – replace mode of practice.

This study is borne out of the researcher’s curiosity, sympathy and desire to research into the existing methods of electronics troubleshoot and explore better way(s) of doing the same. The damage done to many Television set, like any other electronic devices/appliances by the so call (unskilled) technicians are enormous and invaluable and as such this has made every client to be sceptical of all electronics technicians, even the professional ones.

A critical look at the mother board (circuits board) of any television set taken to technician workshop for repair would reveal that ‘remove-test-replace’ is the common practice is their repair. Some parts of the board not connected at all with the main fault would be tampered with, until the fault is being rectified (if lucky). Therefore, leaving the board rough, burnt, or even damaged.

The computerization of television troubleshooting operation package is a mini-expert system that will assist today’s technicians immensely in the faults tracing, faults detection, fault diagnoses, repairs and replacement of components without damaging the board or any other components. Simple way of servicing Television set is also included. It is expected to safe the technicians precious time, labour and money. And it is to promote efficient performance and maintain the life span of the clients television sets.

television sets.

However, this project work cannot and should not be substituted for all television sets circuit diagrams, but to help in localizing the fault to a minimum. Also little is being mention on the colour circuits of television sets, this was because the fault is uncommon, and the time and money required for this section is beyond the immediate reach of the researcher.

The initial take-off cost (change over) and implementation of this work might appeared a bit expensive, but the economic advantage and all other advantages manifests in less than four (4) months and it continues.

It is the hope of the researcher that this work will be a contribution to the data bank on electronics troubleshooting and repairs.

TABLE OF CONTENTS

Page

Title page	i
Certification	ii
Dedication	iii
Acknowledgement	iv
Abstract	v
Table of contents	vi
List of figures	
CHAPTER ONE	
1.0 Introduction	1
1.1 Historical background and development of Electronics	2
1.2 Application of Television	4
1.3 Statement of the problem	10
1.4 Source of data and information of the study	10
1.5 Objectives of the study	10
1.6 Significance of the study	11
1.7 Need for the study	11
1.8 Limitation of the study	12
1.9 Definition of Terms	12
1.9.1 Organisation of the study	14
CHAPTER TWO	
2.0 Literature review	16
2.1 Types of Television receivers	16
2.2 Receiver circuits	17

2.3	Dividing the receiver into sections	25
2.4	Receiver controls	27
CHAPTER THREE		
3.0	Research methodology	31
3.1	Design and procedure	31
3.2	TroubleShooting TV operation	32
3.3	Localising receiver trouble to one section	36
3.4	Multiple problems	38
3.5	Trouble Shooting Techniques	39
3.6	Safety features	43
3.7	Feasibility study	46
3.7.1	Operation of the existing system	46
3.7.2	Problem with the existing system	48
3.7.3	System specification	51
3.8	Cost Analysis	52
3.9	Benefit Analysis	52
CHAPTER FOUR		
4.0	Analysis and interpretation of data	54
4.1	Maintenance section	54
4.2	Service section	55
4.3	User's Guide	55
4.4	Programming Language	56
4.5	Coding of program	57

4.6	Program Documentation	58
CHAPTER FIVE		
5.0	Summary, Recommendation and Conclusion	62
5.1	Summary	62
5.2	Recommendation	64
5.3	Findings	65
5.4	Conclusion	66
5.5	Suggestion for future researchers	66
References		
Programs		

CHAPTER ONE

1.0 INTRODUCTION:

Today's colour Television receivers make use of the most advanced state of the art in electronics. This means that, in addition to vacuum tubes, the latest colour television receivers employ transistors and integrated circuits.

Both of these solid state devices are also found in increasingly more frequent applications in monochrome Television receivers, particularly in the smallest, portable sets. Integrated circuits are coming into ever increasing use in high fidelity audio equipment as well as in colour TV receivers and the special methods of trouble shooting equipment using integrated circuit should be at the finger tips of every technician.

Manufacturers have replaced individual functional sections of the colour receivers with integrated circuits, while special power transistor replace vacuum tubes. This process will continue until, eventually, all TV sets use integrated circuits for the low power functions and transistors for all high power functions. It is impossible to anticipate the detailed circuits that will be used but this work will provide the reader with a clear description of the functional requirements of each circuit so that the user will be able to handle any defects.

This work is designed to give the user knowledge of the principles of (colour) television and to teach servicing of television receivers. Though understanding black and white is a prerequisite to any course in colour TV, just as a knowledge of radio is necessary to understand either branch of television.

The reader should know the principles of radio, television receiver circuitry, and have some knowledge of television servicing before starting and using this

work; an understanding of these subjects is taken for granted and well known principles are not explained again.

1.1 HISTORICAL BACKGROUND AND DEVELOPMENT OF ELECTRONICS

Wireless transmission can be taken as starting with the work of Heinrich Hertz, a German physicist. In 1887 he was the first to demonstrate by experiment the process of electromagnetic radiation through space. The distance of transmission was only a few feet. However, it demonstrate radio waves travelling from one place to another without the need for any connecting wires between the transmitting and receiving equipment.

Hertz proved that radio waves, although invisible, travel with the same velocity as light waves. In fact, radio waves and light waves are just two examples of electromagnetic waves a form of energy that combines the effects of electricity and magnetism. Additional examples of electromagnetic waves include heat radiation, x-rays, and cosmic rays, among others, all of which can transmit energy through space without the need for any connecting wires.

The work of Hertz followed earlier experiments on electricity and magnetism. In 1820, a Danish physicist, H.C. Oersted, showed that an electrical current produces magnetic effects. Then in 1831, a British Physicist, Michael Faraday, discovered that a magnet in motion can produce electricity. In 1864, the British Physicist, James Clerk Maxwell, on the basis of work in electricity and magnetism, predicted the electromagnetic waves demonstrated later by Hertz.

In 1895, Guglielmo Marconi used a long wire antenna and developed a

practical radio system for long-distance communication across the Atlantic Ocean in 1901.

The rapid advances after that are due largely to the introduction and progress of the vacuum tubes. In 1906 Dr. Lee De Forest, with his audion tube that could amplify electric signals, was a leader in this field.

As the design of vacuum tubes advanced, radio broadcasting progressed rapidly. Regularly scheduled programmes were broadcast in 1920 by station KDKA in the AM (amplitude modulation) radio band. The commercial FM (frequency modulation) broadcast service for sound programmes was started in 1939. Stereo broadcasting in the FM radio band began in 1961.

With regard to television, after discarding previous mechanical systems that used rotating drums or disks, commercial television broadcasting was adopted officially in July 1941, although its popular use did not begin until 1945. Our present colour television system was adopted in 1953.

Now with the invention of transistors in 1948 at Bell Telephone Laboratories, there are new application in electronics and radio. The transistor is an application of controlled electron flow in solids such as germanium and silicon. Tubes and transistors both have similar applications for amplification or control purposes. The transistor is smaller however and more efficient because there is no heater. See fig 1-1. Solid state electronics using semiconductors includes not only transistors and diodes but also the integrated circuit (IC) in fig. 1d. It combines these semiconductor components in one solid chip with the required resistors and capacitors.

1.2 APPLICATIONS OF TELEVISION

Television means "To see at a distance". In our practical television system, the visual information in the scene is converted to an electric video signal for transmission to the receiver. Then the image is reassembled on the fluorescent screen of the picture tube (Fig. 1-2). In monochrome television, the picture is reproduced as shades of white, gray, and black. In colour television, the main parts of the picture are reproduced in all their natural colours as combination of red, green, and blue.

Originally, the techniques of television were developed for commercial broadcasting, which started in 1941. The ability to reproduce pictures electronically has proved so useful though that many more applications of television are used for education, industry, business, and visual communications in general. The main applications are:- Television broadcasting, cable Television (CATV), closed-circuit Television (CCTV), picture phone, faesimile, satellites for World wide television, CRT numerical displays and video recording etc.

1. **Television Broadcasting:** The term "broadcasting" means to send out in all directions. As illustrated in fig 1-3, the transmitting radiates electromagnetic radio waves that can be picked up by the receiving antenna for commercial television broadcast stations, the service area is about 25 to 75mi in all directions from the transmitter. The radiation is in the form of two of carrier waves, modulated by the desired information. Amplitude modulation (AM) is used for the picture signal. However, frequency modulation (FM) is used for sound signal.

Referring to fig 1-3, we see that the desired sound for the television

programme is converted by the microphone to an audio signal, which is amplified for the sound-signal transmitter. For transmission of the picture, the camera tube converts the visual information into electrical signal variations. A camera tube is a cathode-ray tube (CRT) with a photo-electric image plate. A common type is the vidicon camera tube shown in Fig 1-4.

The electrical variations from the camera tube become the video signal, which contains the desired picture information. The video signal is amplified and coupled to the picture-signal transmitter for broadcasting to receivers in the area.

Separate carrier waves are used for the picture signal and sound signal, but they are radiated by one transmitting antenna. Further more, the picture and sound signal are included in the broadcast channel for each station. A television channel for a commercial broadcast station is made 6 MHz wide to include both the picture and sound. At the receiver also, one antenna is used for the picture and sound signals. See table 1-1 for television channels and frequency bands.

The receiving antenna intercepts the radiated picture and sound carrier signals, which are then amplified and detected in the receiver. The detector output includes the desired video signal containing the information needed to reproduce the picture. Then the recovered video signal is amplified and coupled to a picture tube that converts the electric signal back into light.

Reproducing the picture:- The picture tube in Fig. 1-5 is very similar to the cathode-ray tube used in the Oscilloscope. The glass envelope contains an electron-gun structure that produces a beam of electrons aimed at the fluorescent screen.

When the electron beam strikes the screen, it emits light.

When the signal voltage makes the control grid less negative, the beam

current is increased, making the spot of light on the screen brighter. More negative grid voltage reduces the brightness. If the grid voltage is negative enough to cut off the electron-beam current at the picture tube, there will be no light. This state corresponds to black. A colour picture tube has three electron guns for the tricolour screen.

The picture tube is also called a Kinescope or a CRT. Its function is to convert the video signal into a picture.

Colour Television:- The block diagram in Fig 1-3 illustrates the television broadcasting system for monochrome. In colour television, a colour camera is necessary at the transmitter and a colour picture tube at the receiver. The colour camera provides video signal for the red, green, and blue picture information. A colour picture tube has red, green, and blue phosphors on the viewing screen to reproduce the picture in colour. A typical colour receiver block diagram is shown in Fig. 1-6.

2. **Cable Television (CATV):-** A cable television system provides broadcasting service by a network of coaxial cables. The rf sound and picture carrier signals, including colour, are distributed as standard 6MHZ channels to subscribers who pay for this service coaxial cable is used because its shielding eliminates pickup of interference or radiation by the lines. The cable supplies at least 1MV of signal for a strong picture with no snow and no ghosts.

Cable television started as an aid for improving reception in two opposite types of locations. We have television broadcasting in the VHF band of 30 to 300 MHZ and the UHF band of 300 to 3,000 MHZ. However, the distance for wireless

transmission becomes much shorter at these high frequencies. Broadcasting is practically limited to the line-of-sight distance between the transmitting and receiving antennas in the VHF and UHF bands. The useful service range is up to 75 mi for VHF stations and 25 to 35 mi for UHF stations.

Another problem in the VHF and UHF bands is that the wave length is short enough to allow reflections of the signal by metal structures, such as bridges, steel building, and even airplanes. The result is multipath reception of the direct and reflected signals. In the picture, the multipath signals produce multiple images called ghosts.

The signal is weak in remote areas far from the broadcast transmitter or in a valley blocked by mountains. In big cities, the transmitter may be close, but tall buildings cause multipath reflections. For all these types of location, cable television has solved the problem.

The method of broadcasting television signal by cable apply to several other applications, which are also important but on a smaller scale. For instance, in a hotel, motel or apartment house, a master antenna can supply signal for all the outlets in the building. This system is called master-antenna television (MATV).

3. **Closed-Circuit Television (CCTV):-** In this system the video signal output from the camera is connected directly by cable to monitors at a remote position, where the picture is reproduced on the screen of the picture tube. A television monitor is a receiver without the rf and if circuit for tuning. About a 1-v peak to peak video signal is required for the monitor. There are many number of possible uses for CCTV in education, industry, medicine, and the home, but just a few are

listed here below:-

- a. **Education:-** One teacher for many classrooms; closeup views of experiments.
- b. **Industry:-** Night watchman; remote inspection of material; observe nuclear reactions.
- c. **Business:-** Train personnel; observe customers and sale people.
- d. **Traffic Control:-** Observe both ends of a tunnel or bridge; control freight traffic.
- e. **Home:-** Door monitor; baby sitter; observe person sick in bed.
- f. **Surveillance:-** Stores; banks; traffic control; crime control etc.

Since the video signal is not transmitted CCTV equipment need not follow the standards of television broadcasting.

Picture Phone:- This system adds television to the telephone service, so that we can see as well as hear each other. A picture phone installation includes a CRT display unit and small camera for the picture with a 12-button phone. The picture has 250 lines per frame, 30 frames per second, and video frequencies limited to 1 MHZ. However, more scanning lines and a wider video frequency band width may be used for a picture with better resolution. Picture-phone service is also useful for showing still picture of drawings, photo graphs and equipment.

Facsimile:- This application is the electronic transmission of visual information, usually a still picture, over telephone lines. Facsimile is also called slowscan television. Since there is no motion in the scene, the scanning for facsimile can be relatively slow. A typical rate is 360 scanning lines per minute. One important use is the facsimile mail service being in use today.

Satellites for Worldwide Television:- Transmission in the VHF and UHF is limited to the line of sight distance to the horizon. Therefore, satellite stations circling the globe are necessary for television transmission over long distances. A satellite orbit is hundreds to thousands of kilometres about the earth satellite for World wide communications are now an established part of television and telephone service. A further step for satellite is a domestic system in each country. Work is being done on satellite to broadcast directly to receivers throughout the country, using the standard 6-MHZ channels in the united states television.

Example of satellite is the communications satellite corporation (COMSAT) operated in United States in cooperation with the 82-nation International Telecommunication Satellite (Intelsat) consortium.

The intelsat IV is a relay station for international communications, providing either 5,000 two-way phone circuit or 12 simultaneous colour TV broadcasts. Typical transmission frequencies are 6,000 MHZ to the path to the satellite and 4,000 MHZ for the down path to the ground station.

The ground station converts the satellite signal to local standards for transmission on commercial TV broadcast channels. With different television standards in Europe and the United States, a converter at the ground station changes the video signal to the required form. The scanning standards are 525 lines per frame and 30 frames per second in the United States, Canada, South America, and Japan. However, most of Europe and Africa uses 625 lines per frame and 25 frames per second. Furthermore, our colour system uses the National Television Systems Committee (NTSC) method. In Europe, the phase-Alternate-Line PAL system is generally used for colour television. The converter at the ground station

can change between scanning standards; from PAL to NTSC colour or from NTSC to PAL colour.

Tape Recorder:- In video tape recording, the video signal is recorded on magnetic tape, similar to the process of tape recording for audio signal.

With all the aforementioned services provided and uses of television, the needs for its existence maintenance, servicing and repairs cannot be over emphasized. Hence the statement of the problem.

1.3 STATEMENT OF THE PROBLEM

The problem of this study is to examine the present ways of servicing and repairs of Television. And to proffer the more efficient, effective, easier, time conserving less labour methods of troubleshooting operations.

The use of computer in localizing the problem area, and suggesting the likely defective electronic component(s) in the circuit for prompt repairs. Hence "Computerized Television Trouble Shooting Operations" (COTTOP).

1.4 SOURCE OF DATA AND INFORMATION OF THE STUDY

The data and information used in this study were obtained from text books; journals, hand books, hand-outs, and manual and note books.

Data and information were also collected from Electronics Engineers, technicians, television users and personal experience.

1.5 OBJECTIVES OF THE STUDY

The objectives of this study are:-

- i. To analyse the trends in the development and applications of television.
- ii. Examine the existing the present method of repairing and servicing television.
- iii. To section television into parts for easy diagnosing.
- iv. To design a program (interactive) that ease and aid in trouble shooting operations.
- v. To reduce cost of repairs.

1.6 SIGNIFICANCE OF THE STUDY

The researcher hopes that this study would:-

- i. Contribute in no small measure in both theory and practical to the existing pool of knowledge about television servicing/trouble shooting.
- ii. Eliminate or reduce "try and error" method of repairing television.
- iii. Encourage very efficient and effective use of human and materials resources.

1.7 NEED FOR THE STUDY

- i. The need for this study arose from the researcher's observation on the present methods of repairing television.
- ii. In many instances, technicians spent undue time in order to repair simple fault(s) in television. Even some technician cause more damages to sets than repairs.

iii. Also, there is need for proper recording of trouble shooting using the right tools for the right job cannot be over emphasized.

iv. The need to meet the present days expectation of computerization is very essential for this study.

1.8 LIMITATION OF THE STUDY (SCOPE)

The study is centred and concentrated to computerised television trouble shooting operations. It does not specifically limited to particular brand(s) of television, but based on the general layouts and principles of television circuit.

The study can not teach a novice of electronics how to trouble shoot, therefore, basic knowledge is essential.

The scope of this study can only serve as a guide to the likely problem(s) and traced to the general defects.

The study can never be substitute for the manufacturers manual/circuit diagram of the television.

1.9 DEFINITION OF TERMS

Here definition of some technical terms is made, therefore, the definitions are made to convey the researcher's meaning of the terms, though they may mean any other things in any other (work) studies.

AFT - Automatic Fine Tuning: This is actually Automatic Frequency Control (AFC) on the local oscillator in the rf tuner. It is generally needed when changing channels, especially with remote control.

AGC - Automatic Gain Control varies the gain of the receiver according to

signal strength. Less gain is needed for strong signals.

B-Y Signal - Colour mixture close to blue. Phase is 180° opposite from colour sync burst. Bandwidth 0-0.5m.

Chromnance Signal - Also called chroma signal or C signal. Is 3.58MHZ colour sub-carrier with quadrature modulation by I and Q colour video signals. Amplitude of C signal is saturation. Phase angle is hu

Colorplexer - Also called multiplexer. Combines C signal and Y luminance signal.

G-Y signal - Colour mixture close to green. Bandwidth is 0-0.5MHZ usually formed by combining B-Y and R-Y video signals.

Hue - Also called tint. Wavelength of light for the colour.

I Signal - Colour video signal transmitted as amplitude modulation of the 3.58MHZ C signal. Hue axis is orange and cyan. This is the only colour video signal with bandwidth of 0 to 1.5MHz.

If - Intermediate frequency.

Luminance - Also brightness for either colour or mono-chrome information. Luminance information is in the Y sign.

Matrix - Combines signals in specific proportions.

Mono-Chrome - In black and white. Just luminance or brightness without colour. Also called achromatic. The Y signal is a monochrome signal.

RF - Radio Frequency (rf).

R-Y Signal - colour mixture close to red. Band width is 0 to

0.5MHz.

Saturation - Intensity of Colour.

Snow - Random noise generated in the receiver circuits which is amplified to produce the white speckles in the picture.

Sub carrier - A carrier that modulates another carrier wave of higher frequency.

Raster - The rectangular area scanned the electron beam as it is deflected horizontally and vertically.

Synchronous demodulator - Detector circuit for a specific phase of the modulated signal.

Tuner - The rf amplifier, mixer and local oscillator stages that form the rf tuning section.

White - contains red, green and blue in the proportions

$$Y = 0.30R + 0.59G + 0.11B$$

1.9.1 ORGANISATION OF THE STUDY

This study is divided into five chapters in the order of;

Chapter one - It includes the introduction, Historical background and development of electronics, application of television, statement of the problem, sources of information use on the study, objective, significance, need and limitation of the study are also highlighted here.

This chapter also include definition of terms used and organisation of the study.

Chapter two - Review of related literature is in this chapter. Mention is also made

of electronic applications components and circuits. Types of television receivers and television receiver circuits are equally discussed.

Chapter Three - It explains the design and procedure used in the collection. List of tools and testing instrument required for trouble shooting are stated. Instrumentation of data gathering, trouble shooting receiver operation and localization of receiver defects to a particular section are mentioned. Explanation is also made on safety features printed-Wiring board and receiver circuit components.

Chapter Four - This deals with the analysis and interpretation of data collection or collected. Trouble shooting and servicing techniques is in this chapter. It also contains User's guide, algorithms program listing, printed screen and copy of a program output.

Chapter Five: - This is the last chapter which has the summary, recommendations and conclusion in it. Suggestion for the future researcher(s) are also made.

CHAPTER TWO

2.0 LITERATURE REVIEW

This chapter deals with the study and review of the related literature on the subject in question, that is "Computerised Television Trouble Shooting Operations". The topic is trying to find a technical solution to the existing try and error method, and to save electronic technicians time and undue labour spending on the repairs of Television. And also to advance computer toward the yearning for computerization of electronic systems.

Although, as the the time of this study the researcher could not find much literature works done of this subject, therefore, decided to use the available materials.

2.1 TYPES OF TELEVISION RECEIVERS

For either monochrome or colours, the receiver may use tubes for all stages, have all solid-state transistors and integrated circuits, or combine tubes and transistors as a hybrid receiver. A typical hybrid chassis for a monochrome receiver is shown in fig 2.1.

1. All - Tube Receivers

This type applies mainly to monochrome receivers and older colour receivers- At the functions are provided by about 12 tubes for monochrome and 18 tubes for colour receivers included are multipurpose tubes with two or three stages in one envelope. The B+ for plate and screen voltage is 140v or 280v.

2. Solid - State Receivers

In this type, all the stages except the picture tube use semi-conductor diodes, transistors, and integrated circuits. The dc supply voltage, then, is about 12 to 90v, for collector voltage transformer is used, or the filament can be heated with direct current from the low - voltage power supply.

3. Hybrid Receivers

In this type, the deflection circuits generally used power tubes, while the signal circuits use transistors and integrated circuits. These receivers usually have an ac-dc power supply, with series heaters for the tubes. The collector voltage of 12 to 28v for the transistors can be taken from the dc bias voltage of the horizontal deflection amplifier.

2.2 RECEIVER CIRCUITS

See the block diagram in Fig 2-1, with typical waveshapes. These circuits are essentially the same for monochrome and colour receivers. For a colour broadcast, the chrominance signal is part of the video signal. In monochrome receivers, however, this 3.58 MHz C signal is just not used, as the video amplifier attenuates frequencies above 3.2 MHz. The type number 18 VAP4 for the monochrome picture tube indicates that 18 in. is the screen diagonal and P4 is the phosphor for a whit screen.

1. Antenna Input

Starting with the antenna signal, the picture and sound rf carrier signals are intercepted by a common receiving antenna the transmission line connects the antenna

to the receiver-input terminals for the rf tuner. Twin lead is generally used. This type is a balanced line, without a ground, without a ground, and unshielded. The characteristic impedance for rf is 300ohms (ohms).

When there is a problem of interference, it may be better to use shielded coaxial cable. This line has high attenuation of the signal, however, especially for the UHF Channel frequencies. Coaxial cable has a characteristic impedance of 75ohms.

Two ungrounded screw terminals on the receiver are connections for 300ohm-twin lead. A grounded jack is for coaxial cable. To convert one type of line to the other type of connection, a balancing transformer (balun) is used. Most receivers now have an antenna jack for coaxial cable, which is generally used, for master antenna and cable Television installations.

There are two tuners, one for VHF Channels 2 to 13 and the other for UHF Channels 14 to 83, each with its own antenna-input terminals. When the antenna and transmission line are the same for VHF and UHF, then a signal splitter at the receiver input is used to separate the signal for the two tuners.

2. Tuners

The antenna input provides rf picture and sound signals for the rf amplifier stage. The amplifier rf output is then coupled into the mixer stage. Also coupled into the mixer is the output of the local oscillator to heterodyne with the rf picture and sound signals. When the oscillator frequency is set for the channel to be tuned in, the picture and sound signals of the selected station are heterodyned down to the lower intermediate frequencies of the receiver.

The rf amplifier, mixer, and local oscillator stages are on an individual subchassis, called the front end, or rf tuner. Either tubes or transistors can be used. With tubes, the local oscillator and mixer functions are usually combined in one stage, called the frequency converter.

The tuner selects the channel to be received by converting its picture and sound rf carrier frequencies to the intermediate frequencies of the receiver.

The fine tuning control sets the oscillator frequency exactly for the best picture. It is important to note that the oscillator frequency determines which channel can be amplified by the IF section. Any problem of receiving the wrong channel is an oscillator trouble UHF tuner operates. The UHF tuner is a separate unit, including transistor oscillator and crystal diode mixer. These two stages serve as the frequency converter to heterodyne the UHF Channels down to the intermediate frequencies of the receiver.

The UHF oscillation is tuned for the desired UHF station. On the UHF position of the VHF tuner, the VHF oscillator is disabled.

3. Picture IF Signal

The picture IF amplifier includes two or four tuned stages using tubes, transistors, or an integrated circuit. The bandwidth is enough for the IF picture signal with its side frequencies and for the IF sound signal. The main function here is amplifying the picture IF signal from the mixer to provide several volts for the video detector. This section is also called the video IF amplifier in schematic diagrams. The gain of the IF amplifier is controlled automatically by the AGEC bias, according to the strength of the signal. The IF amplifier is usually connected to the mixer output

on the rf tuner by a short length of coaxial cable, with a plug on both ends.

The IF value standardized by the Electronic Industries Association for the picture carrier frequency is 45.75 MHz in all receivers. Then the sound IF carrier is automatically 41.25 MHz, separated by 4.5 MHz from the picture carrier. The chrominance signal in the IF amplifier has the frequency of 42.17 MHz, which is 3.58 MHz from the picture carrier at 45.75. The sound and colour IF values below the picture carrier frequency because the rf oscillator beat above the rf signal frequencies in the frequency conversion by the rf tuner.

4. Video Detector

The modulated IF picture signal is rectified and filtered here to recover its AM envelope, which is the composite video signal, needed for the picture tube. The main purpose of the video detector is to provide for the video amplifier the composite video with its camera signal, sync, and blanking.

5. Intercarrier Sound

In addition to the video signal, the output of the video detector in fig.2.1 includes the 4.5 MHz intercarrier sound signal. All television receivers, monochrome or colour, use the intercarrier method of demodulating the sound as a 4.5 MHz signal for all channels, VHF or UHF. However, colour receivers have a separate 4.5 MHz sound converter, instead of using the video detector for this function. The reason is to minimize interference between the sound and colour signals. The advantage of the intercarrier system is that the 4.5 MHz sound signal is automatically tuned in with the picture.

6. Video Amplifier

Consisting of one or more stages, this section amplifies the composite video signal enough to drive the grid - cathode circuit of the picture tube. The camera signal variations change the instantaneous grid-cathode voltage, modulating the intensity of beam current. Then the variations of light intensity, as the spot scans the screen, enable the picture to be reproduced on the raster.

The amount of composite video signal required for the picture tube is about 100v peak to peak for strong contrast cathode drive is generally used.

Note that the composite video signal is also coupled to the sync circuits (where the synchronizing pulses are separated for use in timing the receiver scanning) and to the AGC stage that produces AGC bias for the rf and IF amplifiers.

7. Automatic Gain Control

This automatic-gain-control (AGC) circuit is similar to the automatic-volume-control (AVC) system in AM radios. The stronger the picture carrier is, the greater the AGC bias voltage produced and the less the gain of the receiver. The result is relatively constant video signal amplitude for different carrier-signal strengths. Therefore, AGC for the picture signal is useful as an automatic control of contrast in the reproduced picture. However, the AGC circuit affects both the pictures and sound, since it controls the gain of the rf and IF stages.

8. Synchronizing Circuits

The video detector output includes the synchronizing pulses as part of the composite video signal. This signal, therefore, is also used in the sync circuits. The

sync provides the timing pulses needed for controlling the frequency of the vertical and horizontal deflection oscillators.

Since there are synchronizing pulses for both horizontal and vertical scanning, fig.2.1 shows the output of the sync separator divided into two parts. The integrator is a low pass RC filter circuit that filters out all but the vertical pulses from the total separated sync voltage. Then the vertical synchronizing signals can lock in the vertical deflection oscillator at 60 Hz. For horizontal synchronization, an automatic-frequency-control (AFC) circuit is used to lock in the horizontal deflection oscillator at 15,750 Hz.

9. Deflection Circuits

As shown in Fig. 2-1, these include the vertical oscillator and amplifier for vertical scanning at 60 Hz, with the horizontal oscillator an amplifier for scanning at 15,750 Hz. For either vertical or horizontal scanning, the oscillator stage generates deflection voltage to drive the amplifier at the required frequency the deflection amplifiers are power output stages to provide enough scanning current in the deflection yoke for a full-sized raster.

The horizontal output circuit also includes the damper diode and high-voltage rectifier. The damper has the function of reducing sine-wave oscillations in the horizontal saw-tooth scanning current, which occur immediately after flyback. The high-voltage rectifier produces dc anode voltage for the picture tube.

The deflection circuits produce the required scanning current and the resultant raster with or without the synchronizing signals. Since the deflection oscillators are free running, they sync is needed to hold the deflection oscillators at exactly the right

frequency so that the picture information is reproduced in the correct position on the raster. Without sync, the deflection circuits scan the raster, but the picture will not hold still.

10. Low-Voltage Supply

Two power supplies are shown in fig. 2-1. One is the usual B+ supply for dc operating voltages on the tubes or transistors. This is the low-voltage supply for anode voltage on the compared with the high-voltage supply for anode voltage on the picture tube. For sufficient brightness, the anode voltage for black-and-white picture tubes is 9 to 20 kv, while colour tubes use 18 to 25 kv.

The dc output of 140 to 280 v supplies plate voltage for vacuum tube amplifiers. Silicon diode is generally used as the rectifiers. For transistors and integrated circuits, the required dc supply is about 12 to 90 v, in either positive or negative polarity.

When tubes are used, the heaters can be in parallel with a 6-v winding on the power transformer, or in series for ac-dc sets. With series heaters, all the heater voltages add to equal the power-line voltage of 120v. Open in any one heater opens the entire series string. The heater current for a series string usually is either 450 or 600 in A.

In tube sets having "instant on" operation, the heaters have about one-half their normal voltage with the power switch off. Full power is applied when the receiver is turned on, and the tubes are on almost immediately. This feature has been developed to be similar to solid-state devices, which are on immediately because they

have no heater.

11. High-Voltage Supply

The high-voltage rectifier obtains its ac input from the horizontal amplifier. This arrangement is called flyback supply because the high voltage is generated as an induced voltage during the fast horizontal retrace. The resultant voltage is stepped up by the horizontal output transformer for the required amount of high voltage. The rectified output is the dc anode voltage needed by the picture tube to produce brightness on the phosphor screen. Because the anode voltage depends on the horizontal output with a flyback circuit, there cannot be any brightness on the picture tube screen if the horizontal scanning circuits are not operating.

12. Signal Voltage

For a picture without snow, the required antenna signal is about 1,000 mv or 1 MV. The signal voltage from the tuner into the IF amplifier is about 10 mv. For linear operation of the video detector diode, about 1 to 3 v of IF signal is needed. These are all rms. values for the modulated picture carrier signal.

In the output of the video detector, a typical value of composite video signal for tubes is about 3v, peak to peak, with an average dc level of about 2v. For transistors in the video amplifier, one-half these voltage are typical values.

The peak-to-peak signal out of the video amplifier to drive the picture tube is 80 to 120 v for good contrast. The required dc level or bias for the correct brightness is about 40v, negative at the control grid or positive at the cathode of the picture tube.

2.3 DIVIDING THE RECEIVER INTO SECTIONS

The picture is reproduced on the screen as the combined result of the raster, video signal, and sync. These functions are summarized in Tables 2-1 and 2-2. In addition, fig. 2-2 illustrates the successive steps in forming the raster and superimposing the picture on the raster.

1. ILLUMINATION

Just the spot of light on the screen in fig. 2-2a shows that the picture tube and high-voltage supply are operating. however, it should be noted that this illustration was produced with an external high-voltage source. The flyback supply in the receiver cannot produce high voltage without horizontal output.

2. HORIZONTAL SCANNING

The single horizontal line in fig. 2-2b shows illumination and horizontal scanning. The horizontal deflection circuits, including the horizontal oscillator, amplifier, and damper stages, produce the horizontal scanning.

3. VERTICAL SCANNING

The vertical oscillator and amplifier stages produce vertical scanning. Then the horizontal scanning lines fill the entire screen area from top to bottom to form the scanning raster. The white raster in fig. 2-2c shows that the vertical and horizontal deflection circuits, the picture tube, and high-voltage supply are operating.

4. PICTURE

Figure 2-2d shows a picture reproduced on the raster. The circuits for picture signal, from the antenna input to the picture tube grid, provide video signal for the picture information. Then the video signal voltage varies the intensity of the electron beam, while deflection circuits produce scanning, to reproduce the picture as shade of white gray, and black on the raster.

5. DEFLECTION SYNC

Vertical synchronization allows successive frames to be superimposed exactly over each other so that the picture will not appear to be rolling up or down the screen. Horizontal synchronization prevents the line structure of the picture from tearing apart into diagonal segments. The synchronizing circuits in the receiver provide the horizontal and vertical sync for the deflection oscillators to hold the picture steady.

6. CIRCUITS FOR THE RASTER

In table 2-1 only the raster circuits are listed with the requirements for illumination. Assuming that the picture tube is operating with high voltage to produce light, the horizontal and vertical deflection circuits then can produce the raster.

7. CIRCUIT FOR SIGNAL

Table 2-2 lists these circuits as separate groups, based on the receiver block diagram in fig. 2-1. With intercarrier sound, only the 4.5 MHz circuits and audio amplifier in the second column are for sound alone.

Almost all the signal circuits are for both picture and sound. As listed in the first column, the rf tuner, picture IF amplifier and video detector are common to the picture and sound signals. The AGC circuit controls the gain of these rf and IF amplifiers.

Only the video amplifier is listed in the third column for picture alone, with the sync circuits to hold the picture steady, even the video amplifier can be common to the sound, however, in receivers where the 4.5 MHz signal is taken from the video amplifier output circuit.

2.4 RECEIVER CONTROLS

Those can be considered in two groups: The setup adjustments mainly for the raster and the operating controls in the signal circuits. The setup adjustments for the scanning raster are usually on the rear apron of the chassis. The operation controls are in from panel or at the side of the cabinet.

1. RASTER ADJUSTMENTS

The vertical height and linearity controls are adjusted to fill the screen top to bottom, with the scanning lines equally spaced for good linearity. If there is a width control, it is adjusted to make the raster just cover the left and right edge of the screen. It should be noted that the raster is the same for all stations and is present with or without signal. However, the raster with signal can be a little smaller as blanking crops the edges slightly.

If the raster is off-centre, there are usually magnet rings on the neck of the picture tube that can be rotated to shift the raster vertically and horizontally. It should

be noted that the horizontal hold control could shift the picture slightly with respect to the raster.

2. CHANNEL SELECTOR

The VHF channel switch tunes in the desired station for channels 2 to 13. On the UHF position of this switch dc voltage is supplied to the UHF oscillator to operate the UHF tuner. Then the UHF channel control can be used to select any UHF channel from 14 to 83.

3. FINE TUNING

This control provides more exact setting of the frequency for the VHF oscillator. With intercarrier Sound, the fine-tuning can be set for the best picture, independently of the sound. The best picture with good contrast and fine detail results by setting the fine tuning just off the point where you see wide horizontal sound bars that move with the voice modulation.

4. VOLUME

This is a typical audio level control; usually a potentiometer to vary the signal voltage input to the first audio amplifier, some receivers might also have a tone control to adjust the response for high audio frequencies.

5. BUZZ

Adjust this control, if necessary, for minimum 60Hz buzz in the sound.

6. CONTRAST

Since the receiver generally has AGC to vary the gain of the rf and IF amplifiers, the contrast control is in the video amplifier circuit to adjust the amplitude of video signal voltage for the picture tube.

7. VIDEO PEAKING

Some receivers have this control to vary the high-frequency response of the video amplifier for sharper outlines in the picture. This control is also called fidelity, or sharpness. However, the picture may look better with reduced bandwidth and less sharpness if there is noise or interference in the signal.

8. AGC LEVEL

For proper range of the contrast control, the AGC level setup adjustment at the back of the chassis must be set properly. Adjust the AGC level for full contrast on the strongest station with the contrast control at maximum. Keep the AGC level below the point of overload distortion, however, where black and whites are reversed and the picture is out of sync with buzz in the sound.

9. BRIGHTNESS

This control varies the dc bias for the grid-cathode circuit of the picture tube. Adjust

for the desired overall illumination on the screen. If the picture goes completely out of focus at high brightness levels, the trouble may be insufficient high voltage or an old picture tube that probably has weak emission.

10. VERTICAL HOLD

This control adjusts the frequency of the vertical deflection oscillator close enough to 60Hz to allow the sync to lock in the vertical scanning. When the picture rolls up or down, the vertical hold control is varied to make the picture stay still.

11. HORIZONTAL HOLD

This control adjusts the horizontal deflection oscillator. When the picture shifts horizontally and tears apart into diagonal segments, the horizontal hold control is varied to establish horizontal synchronization and provide a complete picture.

It is interesting to note that many of the controls are similar in their function of varying an ac voltage level. Turning up the volume control increased the amount of audio signal for more volume. Similarly, the contrast control increases the amount of video signal for more contrast. Also, the colour control increases the amount of 3.58 MHz chroma signal for more colour in the picture. In addition, the height control increases the amount of vertical sawtooth scanning current for more height in the raster. A width control increases the amount of horizontal sawtooth scanning current-

CHAPTER THREE

3.0 RESEARCH METHODOLOGY:

Research is a process of finding out the aspects of knowledge or idea which people have not known about or they are not clear about them. It is also a process of finding out new information, new methods of doing things and an extension of boundary of knowledge. A researcher conducts research to answer questions to which there has been no definite answer available and to which no categorical statement has been made. A research starts with an idea or a plan which is generally followed by conducting a pilot study.

There are four main methods of knowing things:-

- i. Method of tenacity: - Tenaciously claiming to know something.
- ii. Method of authority: - Accepting the truth based on authority.
- iii. Method of Intuition: - Using feeling, reasoning and logical series.
- iv. Method of Science: - Systematic investigation.

In the project work, almost all the methods were used

3.1 DESIGN AND PROCEDURE:

In any research work, after the problems to be investigated have been identified, the next step the investigator should take is to plan how appropriately the research can be conducted. The procedure, data collection technique, data collation, data analysis using appropriate statistical tools, data reporting, as well as the complete frame work should be work carefully though. This is where the design and procedure

aspect of the study is important.

3.2 TROUBLESHOOTING (TELEVISION) OPERATION:

The technician who is familiar with TV receivers will be fully aware of the standard tests which are used for practically all electronic equipment. A portion of the circuit is tested wither with the power on and the equipment operating, or with the power off, tracing the signal paths or checking individual components. Component tests usually require only two types of test equipment. Tubes are checked best in the tube tester, while transistors, integrated circuits, resistor, coils, capacitors etc can almost all be tested by means of a good voltmeter or VTVM which contains an ohmmeter section. Detail instructions for these testers omitted here because it is assumed that the reader is thoroughly familiar with them. It will be necessary, however, to refer to such tasks as “check the tubes, check the transistors, measure resistance, check capacity, etc”.

For troubleshooting TV sets a ten-step procedure is recommended which will assure a professional job, the best way to customer satisfaction.

1. VERIFY THE SYMPTOMS

No matter what symptoms the customer may describe, the technician should always verify them because the untrained observer may often miss or misjudge different clues.

The importance of this step will become apparent after the technician has listened to the descriptions customers give for such completely different troubles as sound in the picture, loss of horizontal synch or loss of colour synch.

2. LOCALIZE THE DEFLECT TO THE RESPONSIBLE RECEIVE SECTION

While it is possible to check all of the tubes, transistors, etc. in a TV set, it is not practical and it certainly could waste a lot of time. The symptoms inevitably permit the localization of the defect to a certain functional receiver section which then allow trouble-shooting in a more efficient manner. If the picture appears satisfactory but no sound is obtained, for example, it would be a waste of time to troubleshoot any section other than the audio section. Similarly, the various colour defects can be localized to individual circuits which speed up the troubleshooting procedure greatly.

3. PROBABLE TROUBLE SOURCE

In the following paragraphs and chapter effort will be made trying to point to the most likely source of the defect, based on the reliability of certain components as compared to others and based on the frequency with which certain circuits become defective. It is well known for instance, that vacuum tubes are amongst the least reliable components in a TV receiver and tube checking or tube substitution is therefore a fast way to find many defects.

4. SIGNAL TRACING

If the trouble has not been cleared up by checking one of the likely sources it is usually necessary to trace the signal, such as the audio, video, colour synch, etc., through a portion of the circuitry to find where it is lost or changed substantially signal tracing is a well known technique dating back from the early days of radio and audio equipment, and is still of invaluable help in TV troubles. Sometimes signal

tracing leads directly to the defective component.

5. COMPONENT TESTING

When the signal tracing method leads to a component or group of components it is often necessary that each part be tested individually to find out which one is defective. Having eliminated the most likely trouble spots, component testing is usually confined to measuring the values of resistor capacitors, trying substitutions, checking the continuity and performance of coils and transformers, etc. As mentioned above, the detailed procedure for performing these tests will not be repeated here, in this work, but the components likely to be defective will be pointed out.

6. REPLACEMENT OR REPAIR

Most defective components must be replaced and only ver few, such as poor wiring, can be repaired. The majority of components in a TV receiver are standard, off-the-shelf, items but there are quite a few which are unique for a particular receiver model and for which an exact replacement part is required. In these cases,the exact replacement part must be obtained to assure proper operation.

7. ADJUSTMENT OR ALIGNMENT

Many of the circuits in a colour TV receiver will require adjustment or alignment after a new component has been installed some of these may include RF - IF alignment, colour decoder adjustment and synchronization and CRT colour adjustment.

8. CHECKING THE REPAIR

After the adjustment and the alignment has been accomplished the technician should check the performance of the receiver to be absolutely sure that the defect has been really eliminated. Some defects occur only after the receiver has been warmed up for half an hour or longer and, if the repair and troubleshooting have permitted the chassis to cool down, it may then appear as if the defect has gone away. For this reason it is necessary to check and verify the repair thoroughly, allowing sufficient time for whatever thermal effect might be causing the trouble.

9. CHECKING OVERALL PERFORMANCE

It often happens that a particular defect obscures the existence of other shortcomings of the receiver. Sometimes several symptoms occur simultaneously, one defect causing another, with only the ultimate one, such as no picture at all, becoming apparent. For this reason it should be standard practice for any professional technician to check the overall performance of the receiver carefully and make sure that good pictures and good sound are obtained on all channels used in the particular area. This process offers the technician an opportunity to install a better antenna, sell an antenna rotator, or perform some additional work in order to give the customer the full use of his television set. Checking the overall performance often saves call backs and avoids the customer complaint that; "While the picture is good now the sound is not".

10. DEMONSTRATE THE RECEIVER PERFORMANCE TO THE CUSTOMER

No service call is ever completed until the customer has agreed that all troubles

are cured and that the set really operates well. Before presenting the bill, the customer should be shown all channels, any remaining limitations should be demonstrated and explained, and the customer's satisfaction should be expressed. Find it worth while to affix a sticker with the date and the type of defect that was repaired somewhere on the chassis, as well as to leave your card with the customer for a possible return call.

3.3 LOCALIZING RECEIVER TROUBLES TO ONE SECTION

There are four indicators: The sound, raster, picture, and colour in the picture for colour receivers. Several examples are now analysed to illustrate how the receiver itself indicates where the trouble is. These troubles are based on the block diagram in fig. 3-1 for monochrome receiver.

1. NO RASTER, WITH NORMAL SOUND

Since the sound is normal, the receiver has ac power input, and the low-voltage supply is operating. Assuming that the heater of the picture tube is lit, the trouble of no brightness is usually the result of no anode voltage from the high-voltage supply. Remember that the horizontal deflection circuits must be operating to produce flyback high voltage.

2. NO PICTURE AND NO SOUND, WITH NORMAL RASTER

This trouble is in the signal circuits, before the sound take off point, because both the picture and sound are affected. The circuits common to the picture and sound signals are the rf section, IF amplifier, second detector and AGC circuit.

It is useful to see if there is snow in the raster. Snow is receiver noise generated in the mixer stage. No picture with a snowy raster indicates the trouble is in the rf amplifier or antenna circuits, as the snow from the mixer stage is coming through.

3. NO PICTURE, WITH NORMAL RASTER AND NORMAL SOUND

In the signal circuits, all the stages operating on the sound signal must be normal. The one section in fig. 3-1 operating only on signal for the picture tube is the video amplifier. Therefore, the trouble must be in this stage.

4. NO SOUND, WITH NORMAL RASTER AND NORMAL PICTURE

The trouble must be in the sound circuits, after the sound take off point, because only the sound is affected. This includes the 4.5 MHz sound takeoff circuit, the 4.5 MHz sound IF amplifier, the 4.5 MHz FM detector, the audio amplifier, and the loud speaker.

5. ONLY A HORIZONTAL LINE ON THE SCREEN

The horizontal deflection circuits are producing the horizontal line on the picture tube screen and high voltage for brightness. Only vertical deflection is missing. Therefore, the trouble must be in the vertical deflection section of the raster circuits, which includes the vertical deflection oscillator and the vertical output stage.

6. NO RASTER AND NO SOUND

The screen is completely black, without illumination, and there is no sound. This trouble means the raster circuits and signal circuits are not operating. The defect is likely to be in the low-voltage power supply. Since this section affects both the raster and the signal. A common trouble is an open heater in a series string.

3.4 MULTIPLE TROUBLES

Usually only one defect occurs at a time, but the circuit arrangement can cause multiple effects. The most common examples are series heaters, multiple tubes, flyback high voltage, a common voltage supply and the AGC circuit.

1. SERIES HEATER

When the tube heaters are in a series string, an open in any one heater means that none of the tubes in the string can light, if the receiver has all tubes in one string, the receiver will be completely dead, without any raster, picture, or sound because all the tubes are cold, including the picture tube.

2. MULTIPLE TUBES

As an example, the pentode section of the 6AN8 may be a common IF amplifier, while the triode is used for the vertical oscillator. Then an open heater in this 6AN8 results in no vertical deflection and no picture or sound.

3. COMMON DC VOLTAGE LINES

In many receivers, the picture IF amplifier tubes obtain plate supply voltage

through the audio output stage. In effect, the IF section is in series with the audio amplifier for dc supply voltage. As a result, the audio tube does not conduct, there will be no supply voltage for the IF section, resulting in no picture and no sound.

Another example of stages related for dc voltage often occurs in hybrid receivers. In these circuits, the transistor amplifiers can obtain the collector supply voltage of above 12v from the control grid or cathode of the horizontal output tube.

4. AGC TROUBLES

The AGC circuit affects both picture and sound by controlling the bias of the rf and picture IF amplifiers. When an AGC amplifier tube is used, the AGC trouble can produce a reversed picture, out of sync, with buzz in the sound, caused by over load distortion.

3.5 TROUBLESHOOTING TECHNIQUES

The work required may include antenna installation, replacing the picture tube, adjusting the set up controls, and troubleshooting defective circuits. Alignment is seldom necessary. Most troubles are cause by a defective tube, capacitor, resistor, or semi conductor device. Since tubes are the most common cause of trouble, they should be checked first, preferably by substituting a new tube.

Also, circuits with high values of current or voltage are more likely to have trouble. These include the power supplies and deflection circuits, especially the horizontal output stage. The general idea of localizing the troubles to a section for raster, picture, colour, or sound has been described earlier. Here, attempt is made to analyse specific methods for finding the defective component. In addition, complete receiver

circuits are included to show how all the sections fit together.

It is assumed the trouble has been localized to one stage or section. Remember that the receiver was probably working fine until the trouble happened. Therefore, check for simple problems first. Substitute a new tube and other plug-in components that can be replaced easily. Check for good connections at the pins of a module board or an inter-connecting cable. Power circuits often have a fuse which should be tested.

Then voltage and resistance measurements can be made, using a multimeter (fig. 3-30). Normal dc voltages measured to chassis around are on the manufacturer's schematic diagram. In the signal circuits, the dc voltages are given for no signal input in order to eliminate the effects of AGC bias.

1. DC VOLTAGE TESTS

Always check the dc supply voltages. Then measure the electrode voltages at the pins for tubes, transistors, and IC units. Normal cathode bias voltage on a tube generally means that the plate and screen grid currents are correct. Similarly, normal emitter bias is source bias on a transistor amplifier indicates normal operation. Although the stage is usually amplifying a signal, this function cannot be accomplished without the dc operating voltages.

A dc voltage that is too high indicates an open circuit. Look for an open resistor or coil. Also the tube or transistor may be off, creating an open circuit.

A dc voltage that is too low indicates a short circuit. Look for a shorted capacitor. Also, the tube or transistor may be conducting too much current because of incorrect bias.

2. RESISTANCE TESTS

With the power off, resistors can be checked for an open, which reads infinity on the ohmmeter. An open coil winding or open fuse also has an infinite resistance. Check capacitors for a short circuit, with reads zero on the ohmmeter. In a circuit that has B+ voltage, a shorted by-pass or coupling capacitor changes the dc voltage distribution. However, an open capacitor does not affect the dc voltage.

For resistance checks in transistor circuits, be sure that the ohmmeter does not give a false indication by biasing a junction on. You can open any parallel paths or use reverse polarity for the ohmmeter leads.

Resistors generally do not short but can become open because of age or excessive current. When an open resistor has a bypass capacitor, look for a short in the capacitor. This allows too much current in the resistor, burning it open. A resistor also can be partially open, with too high a resistance Metal-film resistors often open where the leads connect to the film.

3. EFFECT OF AN OPEN CIRCUIT

Not only does an open circuit have infinite resistance, but also its effect can be checked with a dc voltmeter. The voltage is too high at one side of an open circuit and zero at the other side. This voltage check can be used to test a resistor, coil, or fuse for an open.

AC VOLTAGE TESTS

An oscilloscope is used for checking ac video signal and deflection voltages. Normal waveshapes with peak-to-peak amplitudes are shown in the manufacturer's

service notes. In the colour circuits, the waveforms are shown with signal from a colour bar generator.

OPEN CAPACITOR

This possibility can be checked by temporarily bridging the suspected capacitor with a good capacitor in parallel capacitor substitution boxes for this purpose are available with a wide range of capacitance values. With an ohmmeter an open capacitor does not show charging action.

TUBE-SOCKET ADAPTOR

As shown in fig. 3-4, this unit is an extension about 2 in high. You plug the adaptor into the tube socket and the tube into the adaptor. Each pin on the adaptor has a tab for connecting the meter or oscilloscope. This way you can make connections to the tube pins from the top of the chassis.

REPLACING COMPONENTS

Keep the same positions for connecting leads and ground returns. This lead dress is often critical for high frequencies because of feedback and with high voltages to prevent corona and arcing. When replacing a resistor, a higher wattage rating than the original can be used. Also, a higher dc voltage rating is permissible for capacitors, except for electrolytic capacitors, which need the specified forming voltage. Do not replace mica or ceramic capacitors with tubular capacitors, because their inductance can affect the coupling or by passing for high frequencies.

On printed-wiring boards, an individual capacitor or resistor usually can be removed easily by clipping the leads close to the component. Then the new unit is just soldered to the old leads, without disturbing the eyelet connections on the board. However, desoldering tools are available to suck out the solder at the eyelet. Just be careful not to apply excessive heat to the printed wiring.

PRODUCT SAFETY

Many parts in television receivers have special safety related characteristics to protect against arcing, breakdown x-rays, or fire hazard. These features may not be evident just from visual inspection. Such special components are often identified by the manufacturer by a shaded area on the schematic diagram and notes on the part list. When replacement is necessary, the new components should have the required safety characteristics.

3.6 SAFETY FEATURES

In all television receivers the ac line cord is disconnected when the back cover is removed. To operate the receiver with the back cover off, a “cheater cord” is used to fit the male socket on the chassis. The ac-dc type of receiver has a polarized line plug, where the large prong connects to the grounded side of the ac power line. This requires the polarized type of a character cord.

To check which side of the outlet is grounded, you can use a neon – bulb tester or ac voltmeter, from the low side of the outlet to any metal path to earth ground, the ac voltage should be zero, and the neon bulb does not light.

The capacitor of about 0.04 mf as a rf filter across the ac power line is a special nonshorting type. This capacitor should not be replaced with a conventional capacitor.

In addition to the ac interlock for the back cover, the B supply is usually opened when the yoke plug or convergence plug is disconnected.

When servicing a receiver that is not isolated from the power line, it is important to use an isolation transformer. This safety feature prevents a possible short circuit when using line-connected test equipment on the receiver.

The fuses in a television receiver are designed to prevent fire hazard. Do not use larger values and never jump a fuse. Fusible resistors are designed to open with excessive current; these should not be replaced by a conventional resistor. When you are changing wire-fuse links, the replacement must be the exact gage number and length or else the wire fuse will not have the same current rating. A wire-fuse link is often in a sleeve of insulating tubing to catch any dripping, should the fuse melt with an overload. For wired-in fuses, do not mount clips on top for a replacement fuse, as the added weight can move the connections to cause a short circuit.

The high-voltage rectifier for anode voltage is usually in a metal cage as protection against shock hazard and x-radiation. The cover should always be replaced after working in the cage. In some receivers the high-voltage connection to the top cap of the rectifier is open unless the shield cover is in place.

All the metal shields or fish-paper insulators should be in place. The metal shields reduce radiation of signal frequencies between circuits in the receiver, to prevent interference in the picture. Besides insulation, the fish-paper separators help reduce x-radiation.

The lead dress should be kept the same, for several reasons. High -voltage leads must be placed to prevent arcing leads with high-frequency signals can produce feed back or cross talk that causes interference in the picture. In some cases the leads to the picture tube are dressed with specific spacing to serve as spark-gap protection. Always make sure that no wire is touching a hot component, such as a power tube, where the lead may become hot enough to burn.

HEW requires that the receiver not be able to produce a viewable picture when the anode voltage for the picture tube may produce x-radiation. In some receivers, the horizontal oscillator is disabled, resulting in no brightness when the high voltage exceeds the limiting value of approximately 25vk. Or, the horizontal synchronization may be removed to produce a picture that is torn apart in diagonal segments.

For ac-dc receivers without a power transformer, the following procedures are recommended to test for leakage current that can cause a shock hazard at exposed metal parts of the receiver. Leakage current cold check. Disconnect plug from outlet and place a jumper across the two prongs. Turn the receiver switch on use an ohmmeter to check from the shorted plug to exposed metal parts such as the antenna handle, control shafts, and metal overlays and mounting screws. Any exposed metal parts that have a return path to chassis should read 2.2 to 3.3 M. Those parts without a return path to chassis should read infinite ohms for an open circuit. Leakage current hot check. Plug cord into ac outlet and turn receive on connect a 1,500 - ohms resistor and 0.15 microfarad capacitor in parallel. Using long clip leads put this combination in series between earth ground and expose metal parts of the receiver. Measure the ac voltage plug connected in polarities, if the plug is not polarized. The ac voltage measured across R and C must not exceed 0.35v, rms. value. Use a

portable' voltmeter, not plugged into the power line.

3.7 FEASIBILITY STUDY

Feasibility study is concerned with preliminary investigation and it is embarked upon to determine whether the proposed project is feasible or not feasible.

The objectives of the analyst is to clarify and understand the scope of the project which are list in chapter one, starting from the statement of the problem through the end of that chapter.

3.7.1 OPERATION OF THE EXISTING SYSTEM

This is concerned with the ways and manners by which TV sets repair/troubleshooting is being carried out.

The following methods are the most common ways to troubleshoot receivers as at the time of designing this project work.

Try an error method

Sets comparison method

Personal idea method

Group/Team work method

Impromptu repair method

Try and Error Method

This has to do with removing, testing and replacing any or all components the technician feels or assumes is likely to be the problem source, until he is tired or the

fault is detected. This method may take hours, days, weeks or even months depending on the nature of problem and luck/chance of success on the part of the repairer/technician.

Sets Comparison Method

Requires that there have to be good working TV set of the same MAKE, MODEL, SIZE and equal circuit board diagram with the one to be repaired. The technician will thereby be comparing the values of the measured components of the two sets until the fault is detected. This is a good method but requires good professional skill so as not to damage the other working TV set.

Personal Experience/Idea Method

Professional technician with a lot of practical experiences, having good record keeping on repaired system will use this experiences to troubleshoot/repair another TV set with similar problem.

Group/Team Work Method

Sometimes in an organisation having skill technicians, with their wealth of different experiences do jointly repair receivers with complicated problems. Since it is believed that two good heads are better than one, irrelevant parts on the circuit board will not be disturb.

Impromptu Repair Method

This is mostly on a partial contact component(s) when a faulty TV receiver will

start working fine soon as the printed wiring board is touched, shaped, tampered with or disturbed without knowing the particular fault area. Therefore, no real working is done on the TV set.

3.7.2 PROBLEM WITH THE EXISTING SYSTEM

After going through the existing manual methods of diagnosing and troubleshooting of Television receivers the problems identified with the system/methods are: -

Damage to the printed board

More Damage to the receiver

Undue delay in repairs

Malfunctioning of system

Labourious and Boredom in repair

Lack of uniformity of repair

Cumbersome or congestion of Workshop

Requiring sizeable numbers of Trained Technicians

Damage to other receiver

Deceptive repair

1. Damage to the Printed Circuit (Wiring) Board

Due to continuous removing and replacing of components as a result of try and error method of repair, damages are usually done to the printed circuit board. There could open paths of wiring of the board. The legs/pins always appear rough and unattractive thereby pose further problems for future repair.

2. More Damage to the Receiver

One of the serious effects of try and error method commonly use in repairs is that, more damage is sometimes done to the receiver. Some to the good components could be damage when it is disturb by desoldering, removing and resoldering. Even as a result of excessive heat on some components could make them go bad/be destroyed. Therefore, receiver with picture problem might become one without even raster or no picture and no sound, etc.

3. Undue Delay in Repair

It is a common practice for technicians to delay job especially when the fault has not been detected.

Technician can keep a job for days, weeks, months, and even years only to be promising the customer endlessly and at the end the job may not be done. Meanwhile, it could be a very simple problem, having this propose troubleshooting kit at hand.

4. Malfunctioning of System

At times the repaired system/TV receiver using the afore mentioned methods may be malfunctioning after sometimes, if not properly diagonized and cleared. For example, a customer complained of his TV having on sound might later complain snow in the picture three days. After his TV had been repaired of sound problem.

5. Labourious and Boredom in Repair

Technician may spend the whole day without success try to clear of fault of just noisy picture. Some technician sweats and are restless for fault of which the

solution is just at their fingertip, only if they have known.

Lack of Uniformity

It is highly difficult for two technicians to solve problems of the same nature, on the same type of make and model, in the same way giving the men different TV receivers. Fault tracing methods varies from persons to persons depending on factors.

Cumbersome or Congestion of Workshop

It is hard difficult to enter any electronics workshop without seeing at least five to ten (5-10) TV sets unrepaired. Some might have been there for up to ten months, and these technicians are regarded as very competent repairers.

Requiring Sizeable Numbers of Trained Technicians

For fairly good job/repair of TV receivers, a workshop should have reasonable numbers of say five of skills technicians if the present existing methods of repair wish to be maintained, else, the use of the new method shall be highly necessary to meet the modern demands.

Damage to other Receivers

Most especially in the process of comparing system or receivers the technician may damage the working receiver being use for troubleshooting the faulty one.

This has led many technicians into serious trouble and cost him a lot, since both receivers has to be repaired even without any one to use as working receiver for the troubleshooting.

Deceptive Repair

It is sometimes possible to open cover of a faulty receiver and only to clean dust/dirt within the cabinet. But when it is powered to determine the faulty, just to see it working fine again.

The technician may find it difficult to trace fault as this may a partial contact, therefore, will just couple it back only the problem to re-surface few days after.

Therefore, with the above enumerated problems with the existing methods of troubleshooting, there is genius need for a more standard, easier, faster, effective and efficient and modern method(s) of maintenance and repair, hence, computerization and Television Receiver troubleshooting operation

3.7.3 SYSTEM SPECIFICATION

The system specification consists of the hardware and software and the personnel that would operate the computer.

IBM machine or compatible (PC)

Processor

500MB Hard disk

16MB Ram

3.5' Floppy Disk drive

Colour Graphic Monitor

Keyboard

Epson Printed LQ1170

Ups 500VA

MS Dos Version 6.0

Q Basic

3.8 COST ANALYSIS

Requirement		Cost (N)
IBM or Compatibles (PC 486)	-	90,000.00
Printer	-	50,000.00
UPS 500VA	-	20,000.00
MS DOS Version 6.0	-	10,000.00
Printing Papers	-	3,000.00
Installation	-	20,000.00
Maintenance	-	12,000.00
Qbasic	-	10,000.00
Personnel Training	-	5,000.00
TOTAL	-	220,000.00

The initial cost of computerization of Television Receiver Troubleshooting operation excluding the cost of the Technicians for the repairs of TV stood at two hundred and twenty naira (N220,000.00) only.

3.9 BENEFIT ANALYSIS

The benefits/advantages to be derived when the proposed system takes off are:

No further damage to the receiver

Timely repair of TV sets

Labour saving and interesting repair

- Uniformity of repair
- No need of other receiver for comparing
- Many jobs could be done within a very short time.
- Few numbers of Technicians repair in a workshop
- Very Economical
- Standardised billing system is guaranteed
- Effective and efficient troubleshooting is attained
- Good services to customers maintained
- More new customers incurred and former ones kept/sustained
- Workshop is tide up
- Other services such as training, record keeping
- Further computerization of other systems, graphic generation etc. could be derived at a very cheap cost.

From the above analysis, it is therefore necessary to computerize Television receiver troubleshooting operations for effective, efficient, speedy and smooth running of any Television/Electronics repairing workshop, it can therefore be said that the proposed system is operationally feasible.

Technically, the project would be feasible all the specifications, instructions, User's guide and enabling environment are genuinely ensured.

Economically, the investment on the proposed system though could appear high initially but shall surely be recovered in uncountable fold within a short time as the advantages to be derived are great as discussed under the benefit analysis. Remember it is less costly to train a child, than not to train a child.

CHAPTER FOUR

4.0 ANALYSIS AND INTERPRETATION OF DATA

This chapter deals with the detail analyzing and interpreting of the data collected using algorithm representations, programming language and program listing. It also contains the printed screen and copy of a program output as well as the user's guide.

The program of the computerized Television Troubleshoot operation in this project work is broadly divided into two sections, namely: - The maintenance section, and the repair or service section.

4.1 MAINTENANCE SECTION (MAINTAIN T.V)

The maintenance section illustrates the better way of keeping any Television sets like any other electronics appliances working. Maintenance of TV sets is done periodically, say, at a regular interval of six to nine months or at least once yearly. It is preventive measure. The program "MAINTAIN TV" can only be use for the Television set that is still working correctly, otherwise, the "TROUBLE TV" Program should be used for a faulty one.

Maintenance of Television sets is necessary because of these reasons among others:

It is almost the best way to avoid total breakdown of sets.

It prolong the life span of Television sets

It enhances better performance of the sets and efficient (output) production.

It built reliability, confidentiality and avoidance of embarrassment.

It is the most economical and far less expensive.

4.2 SERVICE SECTION (TROUBLE TV)

The section deals with computerized way of reactivating redeeming, reviving and repairing the breakdown TV sets due to lack of maintenance, abuses, carelessness, improper handling, electrical surge/fault, old age, accidental, and/or any other forms of damage of the Television.

The program here is divided into two sub-sections that is, (I) the general trouble an repair of any television and (ii) detail trouble and repair of a particular brand and make of Television sets (PHILIP PRODUCT 17" & 20" TV sets)

4.3 USER'S GUIDE

The importance of this user's guide cannot be overemphasized, as this contained the basic information that will pilot and help the users of this project work to achieve the desired result. Therefore, the following requirements and guidelines are needed.

A basic knowledge of Radio/TV repair is essential (not necessarily to be a professional)

Understanding the reading of electronic circuit diagram is required.

Ability to operate computer (computer literacy) is needed

The user should be able to communicate/understand simple English Language, as the program is an interactive.

The basic tools for the repair such as multimeter soldering iron, lead, sucker, various pliers, screwdrivers, tester, injector etc are to be in place.

The workshops for the repairs should be neat, spacious, well ventilated or cool, well

illuminated, well organized and devoid of obstruction.

Workshop rules and regulations should be observed.

Materials for the replacement of the bad ones should be available.

Extra care is very essential when working on electronics (circuit).

The instructions of the program should be followed.

The sense organs should be involved.

It should be noted that the program language used is Qbase

4.4 PROGRAMMING LANGUAGE

A program is defined as an instruction set describing the logic steps the computer writing is programming language and it involves the following steps:

Problem definition

Problem analysis

Algorithm development

Flowcharting

Coding the program

Prepare test data, run and debug the program

Program documentation

The first and second steps above has been written in chapter three of this work, and is of no use repeating them here. Therefore, the algorithm development and flowcharting are constructed in the form of TV tree 4.4.1 and program flowchart 4.4.2 respectively.

4.5 CODING PROGRAM

Coding is the actual writing of the instructions set the computer follows to solve the problem. This set of instructions is called computer program.

An effective coding results from well-formulated algorithm and flow-charting. Having done these two, coding then becomes just writing instruction according to specified rules. Coding varies from one language to another. Therefore, for the purpose of this project work BASIC PROGRAMMING is used.

BASIC which is an acronym for Beginners All Purpose.

Instruction code was developed in the 1960s at Dartmouth College by John Kemeny and Thomas Kurtz. Since then BASIC has become the most widely used programming language for personal computers; it can also be found on nearly every mini-and mainframe computer. It is a high – level programming language whose method of coding and syntax is oversimplified for whatever class of user, literate children inclusive, and hence from the name it is meant for beginners.

One very vital characteristic of BASIC (DOS). It is availability on all Disk Operating System runs on DOS then you have the BASIC interpreter, these prompted the researcher to use this programming language – BASIC.

The BASIC language has many dialects/versions that are unique to a certain computer. Ever with IBM and compatible microcomputers, there are several dialects such as MicroComputers, there are several dialects such as Microsoft Basic, GW-Basic, and with MS-DOS version 5 we have Qbasic. All the examples should run without difficulty on most of the Basic interpreters for the IBM compatible systems. If you need to know commands that are specific to the BASIC language you are using, check you user manual.

Prepare test data, run and debug the program having coded the program, the next step is to use test data to see the effectiveness or adequacy of the program. A copy of this is in 4.4.4 after debugging. It takes a genius to develop a program that will run at first instance.

4.6 PROGRAM DOCUMENTATION

Documentation entails giving a concise description of programs in form of user (manual) guide in (4.3) and operating instructions. The manual normally includes a detail description of the problem definition (in chapter 3) Flowcharts, Hierarchical Input Processing And Output (HIPO) Chart. [In the forms of 4.4.1, 4.4.2, 4.4.3 & 4.4.4].

The HIPO chart is a chart showing the various input data, the types of operations to be performed and the output from such operations.

Documentation states systems specifications (as in 3.7) as well as the method of putting the program to use.

There are many forms that documentation takes prominent among others are user manual and operating manual. The user manual contains such information that will serve as a guide to the user while the operating manual gives details about the efficient use of the system for the operator.

Generally documentation gives details of what the program can do and what it cannot do as well as simplifying the task of a maintenance programmer and making provisions for future amendments. Thus, to use the program "computerization of Television Troubleshooting operation", After observing the guidelines contained in (4.3) user's guide.

Loading BASIC and the program "TV REPAIR KIT"

The Basic interpreter is provided on you Dos Disk. It can be called by GW BASIC, GW-BASIC, BASICA, BASIC or QBASIC. This must be loaded into the memory of the computer so that it can start loading/translating your program.

Loading BASIC is very easy, but the method depends on the version/dialect of BASIC you are using.

For example, if you are using DOS version 5 or higher the basic steps are listed below:

Switch on you microcomputer and load Dos

Type Qbasic and press < Enter >

Press the < ESC > key

You are now ready to use BASIC. You will have a clear screen except for the commands at the top of the screen.

Then

Type load, followed by the file name TV REPAIR. KIT and press < Enter >

or

- Press F3 of the function keys, followed by the filename TV REPAIR.KIT and press < Enter >

You are now ready to use the program. The program is an interactive one. You can then plug and turn on the Television to be serviced to determine what is the trouble with the set; maintenance or repair if latter, what type of fault? For good and desirable result, you should answer the questions displayed on the monitor of the computer system accordingly and follow the instructions contained therein.

Function keys. The ten function keys on the keyboard are programmed with BASIC reserved words, and as soon as you load BASIC into memory they take on their new functions these commands are especially useful in the immediate mode and some of them are supplied with < Enter > where appropriate. I will only discuss F1, F2, F3, F4, F5 and F9 here. They are of immediate relevance interested reader should check out the meaning of the others in the BASIC manual.

F1 LIST Press F1 followed by < Enter > to list the program. This can be used to modify, amend and update the program if the need arises.

F2 RUN Press F2 to RUN the program in memory.

F3 LOAD This command is used to load BASIC program from disk into memory. To load a program into memory, press F3, followed by the filename (TVREPAIR.KIT) and press < Enter >.

F4 SAVE This command is used to SAVE the program in memory into a file for future reference. To SAVE your program on disk, press F4, followed by the name of the file where you want your program saved, and press <Enter>.

F5 CONT This command is used to continue program execution after < ctrl > + < Break > has been pressed, a STOP instruction was executed, or an error has occurred. Simply press F5 and execution will resume.

F9 KEY BASIC uses the bottom line of the screen display to show the contents of the function keys. You can use function key F9 to turn it on/off. To turn the display off, press F9 and type OFF and type ON then press

< Enter > and the display will come on again. The screen should appear as follows: KEY OFF < ENTER >.

The safety of this program is good storage, proper handling & maintenance and back-up copies to be kept in different locations.

CHAPTER FIVE

0 SUMMARY, RECOMMENDATION AND CONCLUSION

This is expected to be the last chapter of this project work. And brief mentioned of all previous chapters was made here. It also contains what the researcher recommends and his final conclusion on the whole assessment of the old methods and new designed computerized method of Television Troubleshooting operation suggestion is also made here, on the areas where programmers and electronics engineers could dive into for further computerization of Television/Electronics troubleshooting operation so as to have a full data bank on Television/Electronics troubleshooting operations in the country.

5.1 SUMMARY

This work presents the general principles in the black-and -white and colour Television for electronic technicians and for television maintenance and troubleshooting.

The practical explanations of television principles and receiver circuits are planned for the benefits of those who are just starting in television. This work is designed to be a guide, companion, and a powerful tool for television troubleshooting. Principles of colour television are integrated almost throughout the entire work since modern television is mainly in colour. Television receiver circuits are explained with vacuum tubes, transistors and integrated circuits. However, the emphasis is on solid-state circuit in modern receivers.

The first chapter containing application of television describes the many uses

television besides broadcasting. It also traced the background development of television. Mentioned are made on the statement of the problem, sources where data for the study are obtained, the need for the study, the objectives, the significant and the limitations of the study. Few terms are also defined here.

Chapter Two, through expected to be literature review, went further to discuss the types of receivers such as: - all-tube receivers, solid-state receivers and hybrid receiver, since the researcher could not find much works on this subject, he proceeded to discuss the principles of television receiver circuits, television receiver is also divided into sections for detailed explanation with figures of pictures for insight understanding. Still in this chapter receiver controls are explained and still in this chapter:- receiver controls, television components like any other electronics components, printed-wiring board (circuit board) as well as test instruments are explained here.

In chapter three, detailed analysis and full written explanation on television troubleshooting operation, methods of localizing receiver troubles to one section, multiple troubles, troubleshooting techniques and safety features are extensively discussed.

It also contained the feasibility study comprising the preliminary investigation, operation of the existing system or method of troubleshooting/repairs and problems with the present method/system. The new system specifications, cost analysis and benefits analysis to be derived from this new method of troubleshooting are highlighted and discussed in chapter three.

For chapter four that contained the analysis and interpretations of data by using TV tree, algorithms and programming language.

User's guide is also incorporated in chapter four to help user on the use of this project work. Though the general problems and the most likely area of fault are addressed, but for direct indication of particular fault and specific trouble component(s) a brand of Philip product 17 " and 20" is chosen. (It should be note that all types of television receivers, and of all makes, models sizes have the same principles of operations and repairs, so as Philip is chosen any other MAKE may be choose and worked out the same way.

Chapter five which is the last chapter of this work comprises of the summary of the whole work and recommendations as well as the conclusion. Suggestions for the further researchers are also made. And it is the hope of the researcher of this project that the work is going to be a huge success and a break through in the electronics world.

5.2 RECOMMENDATION

Following the study and the outcome of the project work, and for desirable result in the use of the work, the researcher hereby make the below recommendations:-

That this project work should be read through and thoroughly understood especially people with little or poor background in television principles and servicing, before using the troubleshooting program package.

That the knowledge of electronics (repairs) and circuits diagram reading and interpretations are essential.

That the service (diagram) manual of the receiver to be repaired should be use as the one contained in this work can not be a substitute for all MAKES, MODELS, and SIZES of receivers.

That to ensure the best and pleasant result all in this work should be studied and understood. And additional ideas may be added, if there is any.

5.3 FINDINGS

After the thorough research work a testing of the program the researcher made the following findings.

That most of the electronics repairers are using try and error method

That most service men have no standard methods of troubleshooting

That most of electronics technicians causes more damages to TV set than repairs

That most of them do not have equipment and tools for good diagnose an repairs

That it is easy to troubleshoot without touching every components on the circuit board

And most importantly that all components on the printed-wiring board are numbered with three digits.

And that the first digit of the three digits is common to all components in that circuit.

For example, if the number on the point containing horizontal hold control or flyback (line transformer) on the printed-wiring-board is numbered say 703 all components starting with 7-- is for horizontal circuit. Therefore, there is no need to disturb other components not starting with 7 if the fault is in the horizontal circuit.

5.4 CONCLUSION

From the foregone and foregoing this project work can now be concluded that if genuinely pursue and use will make troubleshooting fast, economical, interesting, effective, efficient and far rewarding than the old methods. So all should work toward the ensuring the workability of computerization of Television Troubleshooting Operation.

5.5 SUGGESTION FOR FUTURE RESEARCHERS

It is suggested that the future researcher should design the computerized method of troubleshooting other makes of Televisions and even other electronics system so as to have Electronics Troubleshooting data bank.

REFERENCES

1. Angelo B. J. (1971), 'Electronics B J T's and Micro circuits'.
London: McGraw-HILL International Book company.
2. AYO C.K. (1994), 'Computer Literacy (Operations & Appreciation)'.
Egbe: Alanukitan Commercial Press (Nig.) Ltd.
3. BADMUS A. R. (1997), 'System Analysis and Design'.
Minna: Unpublished.
4. Bernard G. (1974), 'Basic Television. Principles and Servicing'.
London: McGraw-HILL International Book Company.
5. Carison Mc. (1986), 'Communication systems, 2/e'.
London: McGraw-HILL International Book Company.
6. Chute B. (1974), 'Electronics in industry, 4/e'.
London: McGraw-HILL International Book Company.
7. Clement H. (1970), 'Electrical Engineering Science'.
London: McGraw-HILL International Book Company.
8. Corvette. V. (1982), 'Elements of Circuits by System & Computer
Analysis'. London: McGraw-HILL Int'l Book Co.
9. Glyn E. (1980), 'Elements of Computer Science'.
London: McGraw-HILL International Book Company.
10. Graeme D. (1975), 'Application of Operations Amplifiers'.
London: McGraw-HILL International Book Company.

11. Hamilton B. (1970), 'Basic Integrated Circuit Engineering'.
London: McGraw-HILL International Book Company.
 12. Hamilton B. (1974), 'Basic Electronics'.
London: McGraw-HILL International Book Company.
 13. Runyan S. (1975), 'Semiconductor Measurements and
Instrumentation'. London: McGraw-HILL Int'l Book Co.
 14. Schilling D. (1971), 'Electronics Circuits'.
London: McGraw-HILL International Book Company.
 15. Strauss W. (1970), 'Wave Generation and Shaping, 2/e'.
London: McGraw-HILL International Book Company.
 16. Terman K. (1978), 'Electronic and Radio Engineering, 4/e'.
London: McGraw-HILL International Book Company.
- Tobey W. (1970), 'Operational Amplifiers: Design & Applications'.
London: McGraw-HILL International Book Company.

SCHEMATIC CIRCUIT DIAGRAM OF TYPICAL PHILIP TELEVISION

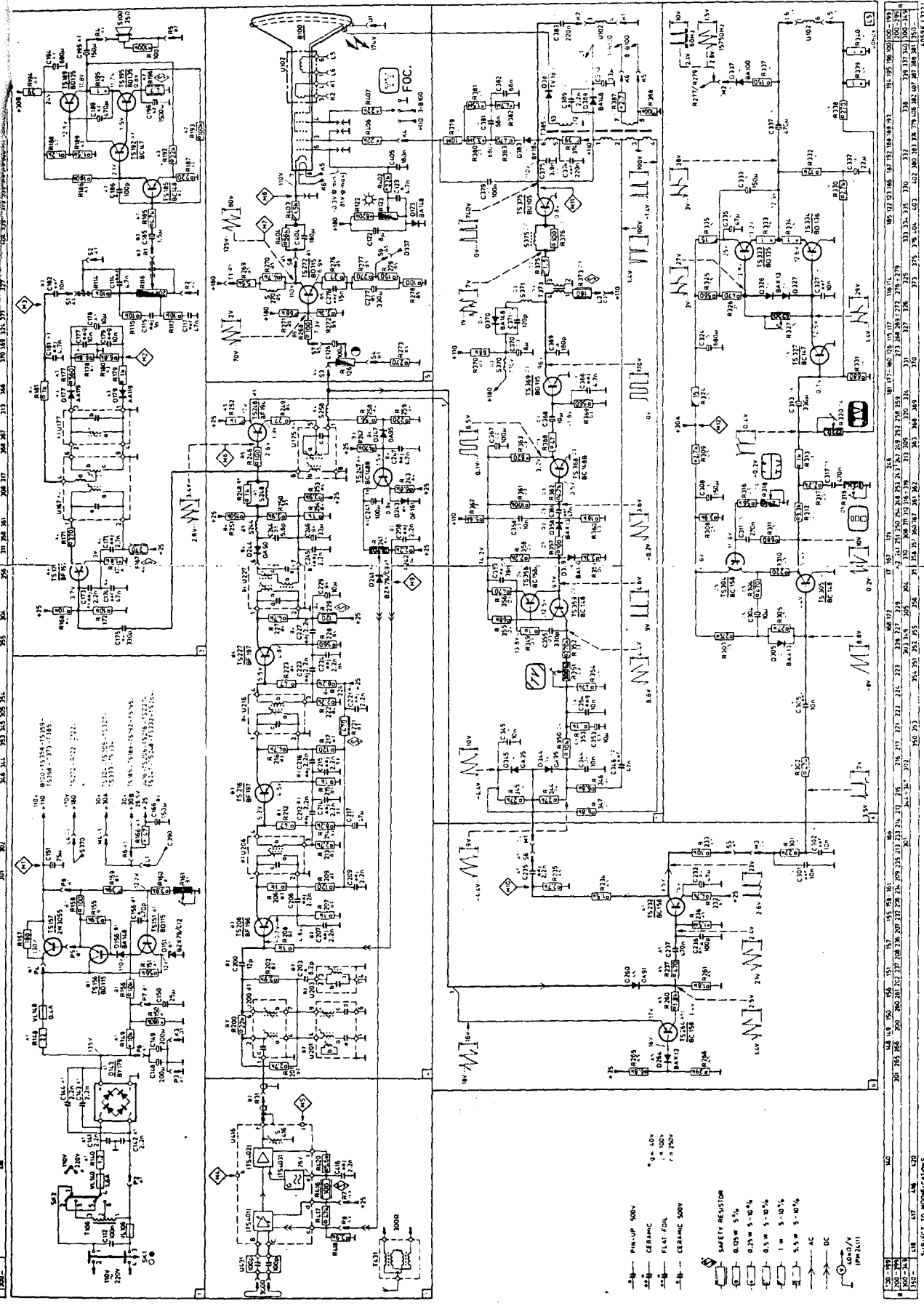

- 6X4 6X5 6X6 6X7 6X8 6X9 6X10 6X11 6X12 6X13 6X14 6X15 6X16 6X17 6X18 6X19 6X20 6X21 6X22 6X23 6X24 6X25 6X26 6X27 6X28 6X29 6X30 6X31 6X32 6X33 6X34 6X35 6X36 6X37 6X38 6X39 6X40 6X41 6X42 6X43 6X44 6X45 6X46 6X47 6X48 6X49 6X50 6X51 6X52 6X53 6X54 6X55 6X56 6X57 6X58 6X59 6X60 6X61 6X62 6X63 6X64 6X65 6X66 6X67 6X68 6X69 6X70 6X71 6X72 6X73 6X74 6X75 6X76 6X77 6X78 6X79 6X80 6X81 6X82 6X83 6X84 6X85 6X86 6X87 6X88 6X89 6X90 6X91 6X92 6X93 6X94 6X95 6X96 6X97 6X98 6X99 6X100
- RESISTOR
- CAPACITOR
- TRANSFORMER
- DIODE
- VACUUM TUBE SOCKET
- SAFETY RESISTOR
- 0.05W 5%
- 0.25W 5-10%
- 0.5W 5-10%
- 1W 5-10%
- 5.5W 5-10%
- AC
- DC
- IMPEDANCE

TABLE OF COMPONENT VALUES AND LOCATIONS

COMPONENT	VALUE	LOCATION
R1	100K	6X4
R2	100K	6X5
R3	100K	6X6
R4	100K	6X7
R5	100K	6X8
R6	100K	6X9
R7	100K	6X10
R8	100K	6X11
R9	100K	6X12
R10	100K	6X13
R11	100K	6X14
R12	100K	6X15
R13	100K	6X16
R14	100K	6X17
R15	100K	6X18
R16	100K	6X19
R17	100K	6X20
R18	100K	6X21
R19	100K	6X22
R20	100K	6X23
R21	100K	6X24
R22	100K	6X25
R23	100K	6X26
R24	100K	6X27
R25	100K	6X28
R26	100K	6X29
R27	100K	6X30
R28	100K	6X31
R29	100K	6X32
R30	100K	6X33
R31	100K	6X34
R32	100K	6X35
R33	100K	6X36
R34	100K	6X37
R35	100K	6X38
R36	100K	6X39
R37	100K	6X40
R38	100K	6X41
R39	100K	6X42
R40	100K	6X43
R41	100K	6X44
R42	100K	6X45
R43	100K	6X46
R44	100K	6X47
R45	100K	6X48
R46	100K	6X49
R47	100K	6X50
R48	100K	6X51
R49	100K	6X52
R50	100K	6X53
R51	100K	6X54
R52	100K	6X55
R53	100K	6X56
R54	100K	6X57
R55	100K	6X58
R56	100K	6X59
R57	100K	6X60
R58	100K	6X61
R59	100K	6X62
R60	100K	6X63
R61	100K	6X64
R62	100K	6X65
R63	100K	6X66
R64	100K	6X67
R65	100K	6X68
R66	100K	6X69
R67	100K	6X70
R68	100K	6X71
R69	100K	6X72
R70	100K	6X73
R71	100K	6X74
R72	100K	6X75
R73	100K	6X76
R74	100K	6X77
R75	100K	6X78
R76	100K	6X79
R77	100K	6X80
R78	100K	6X81
R79	100K	6X82
R80	100K	6X83
R81	100K	6X84
R82	100K	6X85
R83	100K	6X86
R84	100K	6X87
R85	100K	6X88
R86	100K	6X89
R87	100K	6X90
R88	100K	6X91
R89	100K	6X92
R90	100K	6X93
R91	100K	6X94
R92	100K	6X95
R93	100K	6X96
R94	100K	6X97
R95	100K	6X98
R96	100K	6X99
R97	100K	6X100

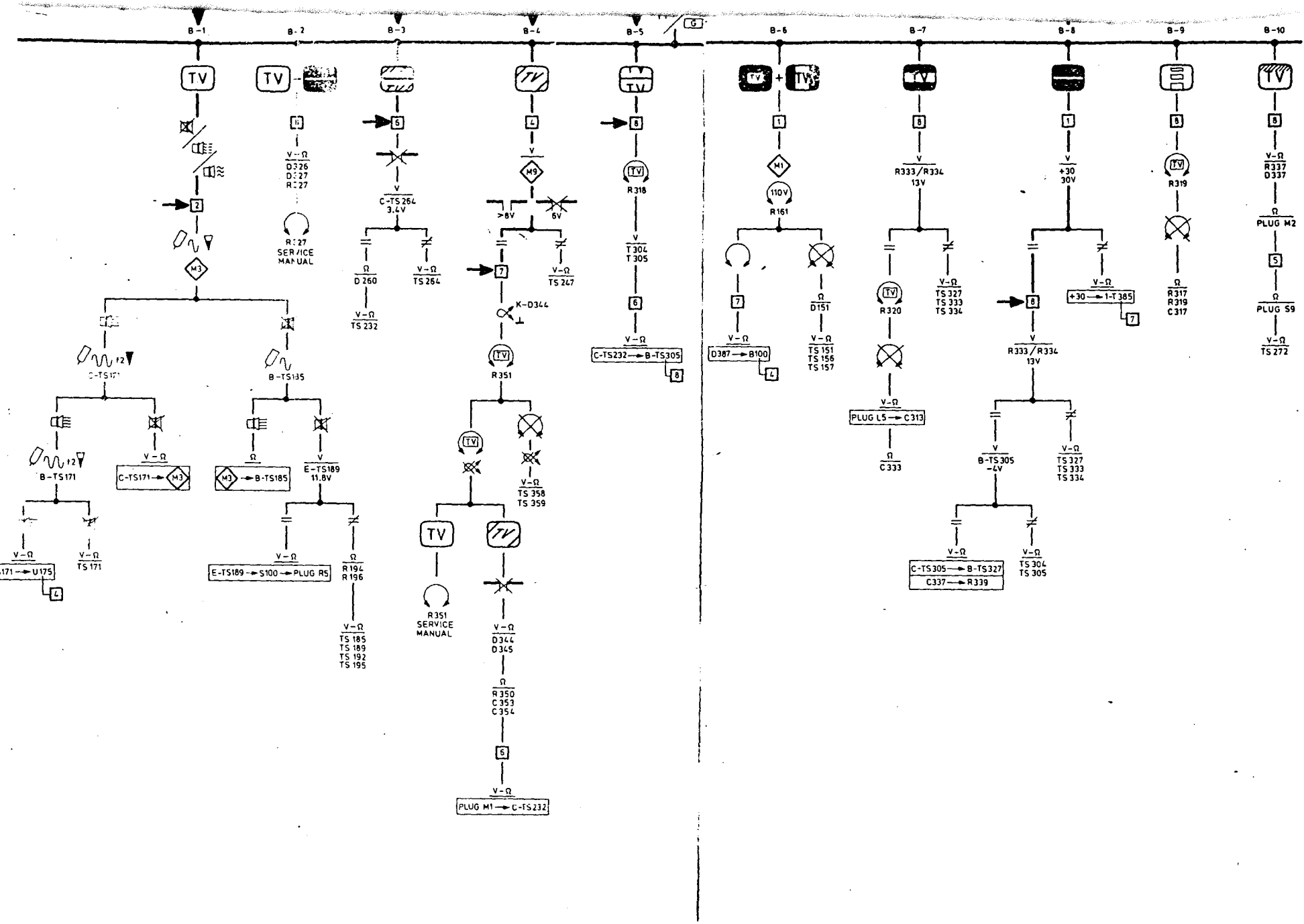

5 REM COMPUTERIZATION OF TELEVISION TROUBLESHOOTING BY OLADIMEJI
T.K

REM [BLACK AND WHITE PHILP PRODUCT] 17" AND 20"

REM BASIC Programming Language

PRINT "Welcome To SURVIVAL OF TELEVISION"

PRINT "REPAIR MEANS NOT (PROPERLY) WORKING BUT TO MAKE TO WORK"

PRINT "SERVICE MEANS PROPERLY WORKING AND TO MAKE STILL WORKING
i.e."

MAINTENANCE ""

CLS

CHOICES\$ = "S"

PRINT "Choose 'R' for Repair and 'S' for Service"

INPUT "Do you want to Repair or Service (R/S) Television", CHOICES\$

CLS

IF CHOICES\$ = "S" OR CHOICES\$ = "s" THEN

REM Procedure for Maintenance Servicing of Television

PRINT "Unplug (Remove) the TV from the main power supply"

PRINT "Loose the Screens of the back cover of the TV"

PRINT "Open the back cover"

PRINT "Use air blower to blow-out dust off TV compartment"

PRINT "Use Soft Painter brush to clean the remaining dust properly"

PRINT "Check and properly clean Tuner unit and other controls"

PRINT "Check the printed-wiring (circuit) board"

PRINT "Any improperly soldered components should be resoldered"

PRINT "Check for about to burnt or wear out components"

PRINT "Replace all defective components"

PRINT "Check the module board on the base of the picture tube"

PRINT "Use soft brush to clean CRT and deflection coils"

PRINT "Reconnect all the cable connections and components removed"

INPUT "Are you sure everything is okay (Y/N)?", CHOICES\$

IF CHOICES\$ = "Y" THEN

PRINT "You can now connect to the main power supply"

PRINT "Put on the TV switch"

INPUT "Does it work perfectly okay (Y/N)?, "; CHOICES\$

IF CHOICES\$ = "Y" THEN

PRINT "Leave it ON for about 30minutes"

PRINT "Cover its back and mark serviced"

ELSE

PRINT "Bad job!"

PRINT "Sorry! Try again"

END IF

ELSE

PRINT "You need to go over again"

END IF

CLS

GOTO 5

```
ELSEIF CHOICES$ = "R" THEN
210  REM Procedure for Repairing Television (Black & White)
REM PHILIP PRODUCT 17"and 20"
PRINT ""
PRINT "Please select the fault through its Number"
PRINT ""
PRINT "1. There is Brighness but NO picture"
PRINT "2. Insufficient Brightness"
PRINT "3. No Brightness at all"
PRINT "4. Noisy Picture"
PRINT "5. Wobbling Picture"
PRINT "6. Uncontrollable Brightness (Too Bright)"
PRINT "7. Steady picture but no sound"
PRINT "8. Sometimes full and collapse picture to vertical line"
PRINT "9. No sync for both vertical and Horizontal"
PRINT "10. No horizontalsync"
PRINT "11. No vertical sync"
PRINT "12. No full picture on vertical or both horizontal & vertical"
PRINT "13. No full picture on horizontal sides"
PRINT "14. Frame collapse (No vertical deflection)"
PRINT "15. No vertical height deflection"
PRINT "16. No vertical linear deflection"
CHOICES$ = "Y"
INPUT "Please enter the number which correspond to the fault in above";
N
IF N = 1 THEN 250
ELSE IF N = 2 THEN 300
ELSE IF N = 3 THEN 350
ELSE IF N = 4 THEN 400
ELSE IF N = 5 THEN 450
ELSE IF N = 6 THEN 500
ELSE IF N = 7 THEN 550
ELSE IF N = 8 THEN 600
ELSE IF N = 9 THEN 650
ELSE IF N = 10 THEN 700
ELSE IF N = 11 THEN 750
ELSE IF N = 12 THEN 800
ELSE IF N = 13 THEN 850
ELSE IF N = 14 THEN 900
ELSE IF N = 15 THEN 950
ELSE IF N = 16 THEN 999
ELSE
PRINT "Wrong Number Entered"
CLS
GOTO 210
END IF
```

```

CHOICES$ = "X"
PRINT "Test the TV set after replacement and proper connections"
INPUT "Is the TV working properly (Y/N)?: "; CHOICES$
IF CHOICES$ = "Y" THEN
PRINT "The TV is working properly"
PRINT "Well done!"
PRINT "The job is very nice!"
ELSE
PRINT "The TV is not working properly"
PRINT "Sorry! Try again"
END IF
PRINT "Wrong CHOICES$ is made (Choose 'R' for Repair & 'S' for
Service)"
CLS
GOTO 5
250 REM There is Brightness but No picture on the TV screen
INPUT "is there Brightness but No picture on the screen (Y/N)"; CHOICES$
IF CHOICES$ = "Y" THEN PRINT "there is brightness but no picture"
INPUT "Is there sound (Y/N)?: "; CHOICES$
IF CHOICES$ = "Y" THEN
PRINT "The sound is okay"
PRINT "Go to block 5 on the circuit diagram"
PRINT "Locate transistor TS 272"
PRINT "Inject the base of transistor TS 272"
INPUT "Is there signal (Y/N)?:"; CHOICES$
IF CHOICES$ = "Y" THEN
PRINT "There is signal on the TV"
PRINT "Goto block 4 on the circuit diagram"
PRINT "Locate transistor TS 248"
PRINT "Test (V- ) transistor TS 248"
PRINT "If the TS 248 is good (otherwise replace)"
PRINT "Locate diode D 244.And measure resistance"
PRINT "If the diode D 244is good(otherwise replaced)"
PRINT "Locate plugs 53,54 and 57"
PRINT "Test/measure resistance ( ) of the plugs (53, 54 & 57)"
PRINT "The fault is within the plugs"
ELSE
PRINT "There is no signal on the TV"
PRINT "Locate and test transistor TS 272"
PRINT "It is bad!"
END IF
ELSE
PRINT "The sound is not okay"
PRINT "Disconnect the aerial"
PRINT "Go to block 4 on the circuit diagram"
PRINT "Locate point M9 and measure voltage at M9"

```

```

INPUT "Did you get 6V at M9(Y/N)?: "; CHOICES$
IF CHOICES$ = "Y" THEN
PRINT "6V at M9"
PRINT "Go to block 1 on the circuit diagram"
PRINT "Locate +25 and measure voltage at + 25"
INPUT "Did you get 26.5V at + 25 (Y/N)?: "; CHOICES$
IF CHOICES$ = "Y" THEN
PRINT "26.5V atpoint + 25"
PRINT "Go to block 4 on the circuit diagram"
PRINT "locate transistor TS 248"
PRINT "Inject (full) the base of transistor TS 248"
INPUT "Isthere signal on the screen (Y/N)?: "; CHOICES$
IF CHOICES$ = "Y" THEN
PRINT "There is signal on the screen"
PRINT "Locate transistor TS 216"
PRINT "Inject (half) the base of TS 216"
INPUT "Is there any signal on the screen (Y/N)?: "; CHOICES$
IF CHOICES$ = "Y" THEN
PRINT "There is signal on the screen"
PRINT "Locate U200"
PRINT "Inject(half)the pin1 of U200"
INPUT "Is there any signal on the screen (Y/N)?:"; CHOICES$
IF CHOICES$ = "Y" THEN
PRINT "There is signal on the screen"
PRINT "Goto block 3 on the circuit diagram"
PRINT "Locate component U416"
PRINT "Test(V- ) componentU416. It is bad!"
PRINT "Replace\change the component U 416"
ELSE
PRINT "There is no signal on the screen"
PRINT "Locate transistor TS 206"
PRINT "Test (V- ) transistorTS 206"
PRINT "It is bad!Replace\change it"
END IF
ELSE
PRINT "There is no signal on the screen"
PRINT "Locate transistor TS 227"
PRINT "Inject (full) the base of Ts 227"
INPUT "Is there signal on the screen (Y/N)?: "; CHOICES$
IF CHOICES$ = "Y" THEN
PRINT "There is signal on the screen"
PRINT "Locate transistor TS 216"
PRINT "Test(V- )transistor TS 216"
PRINT "TS 216 bad! Replace"
ELSE
PRINT "There is no signal on the screen"

```

```

PRINT "Locate transistors TS 227 and TS 248"
PRINT "Test (V- ) of base Ts 227 to base Ts 248"
PRINT "The fault is there! replace where necessary"
END IF
END IF
ELSE
PRINT "There is no signal on the screen"
PRINT "Test (V- ) transistor TS 248"
PRINT "TS 248 is bad! replace"
END IF
ELSE
PRINT "The voltage at point + 25 is not 26.5V"
PRINT "Locate plug L1"
PRINT "Test (V- ) point + 25to plug L1"
PRINT "The fault is there! replace where necessary"
END IF
ELSE
PRINT "The voltage at point M9 is not 6V"
PRINT "Locate transistor Ts 247"
PRINT "Test (V- ) transistor Ts 247"
PRINT "TS 247 is bad! replace"
END IF
END IF
PRINT "The problem is not lack of picture"
REM END IF
GOTO 1000
REM Program for Repairing in sufficient brightness
300 INPUT "Is there insufficient Brightness on the screen (Y/N)?: ";
CHOICES$
IF CHOICES$ = "Y" THEN
PRINT "There is insufficient brightness on the screen"
PRINT "Disconnect the aerial"
PRINT "Adjust the brightness control to the maximum"
PRINT "Adjust the contrast control to the minimum"
PRINT "Go to block 5 on the circuit diagram"
PRINT "Locate point M8 and measure voltage at M8"
INPUT " Is the volatge there 110V (Y/N)?: "; CHOICES$
IF CHOICES$ = "Y" THEN
PRINT "The voltage at M8 is 110V"
PRINT "Locate (CR tube base) B100"
PRINT "Measure voltage at pin 6 of B100"
INPUT "Is the voltage there 80V (Y/N?: "; CHOICES$
IF CHOICES$ = "Y" THEN
PRINT "The voltage at pin 6 of B100 is 80V"
PRINT "Measure voltageat pin 3 of B100"
INPUT "Is the voltage there (greater than) >150V (Y/N)?:"; CHOICES$

```

```

IF CHOICES$ = "Y" THEN
PRINT "The voltage at pin 3 of B100 is >150V"
PRINT "Go to block 7 on the circuit diagram"
PRINT "Locate T387 and B100"
PRINT "Test (V- ) T385 to D387 to B100"
PRINT "The fault is there!replace where necessary"
ELSE
PRINT "The voltage at pin 3 of B100 is not >150V"
PRINT "Locate B100 and T385 in block 7"
PRINT "Test (V- ) pin 3 of B100 to pin of T385"
PRINT "The fault is there!replace where necessary"
END IF
ELSE
PRINT "The voltage at pin6 of B100 is not 80V"
PRINT "Locate B100 and point + 180"
PRINT "Locate (V- ) pin 6 B100 to + 180"
PRINT "The fault is there! replace where necessary"
END IF
ELSE
PRINT "The voltage at point M8 is not 110V"
PRINT "Locate transistor TS 272"
PRINT "Ts 272 is bad! replace"
END IF
ELSE
PRINT "The fault is not an insufficient brightness"
END IF
GOTO 1000
350 REM Program for No Brightness at all on the TV screen
INPUT "Is there no brightness at all (Y/N)?: "; CHOICES$
IF CHOICES$ = "Y" THEN
PRINT "There is no brightness at all on the TV screen"
INPUT "Is there (normal) sound (Y/N)?: "; CHOICES$
IF CHOICES$ = "Y" THEN
PRINT "There is (normal) sound"
PRINT "Locate CRT tube B100 and check filament for light"
INPUT "Is there light in the filament of B100 (Y/N)?: "; CHOICES$
IF CHOICES$ = "Y" THEN
PRINT "There is high in the filament of B100"
PRINT "Disconnect aerial"
PRINT "Go to block 5 on the circuit diagram"
PRINT "Locate point M8 and measure voltage at M8"
INPUT "Is the voltage there 110v (Y/N)?: "; CHOICES$
IF CHOICES$ = "Y" THEN
PRINT "The voltage at point M8 is 110V"
PRINT "Adjust brightness control to the maximum"
PRINT "Locate CRT tube B100 and measure voltage at pin 6"

```



```
INPUT "Is the voltage there 80V (Y/N)? : "; CHOICES$
IF CHOICES$ = "Y" THEN
PRINT "The voltage at pin 6 of B100 is 80V"
PRINT "Measure voltage at pin 3 of B100 (V > 150V)"
INPUT "Is the voltage there (greater than) > 150V (Y/N)? : "; CHOICES$
IF CHOICES$ = "Y" THEN
PRINT "Voltage at pin 3 of B100 is > 150V"
PRINT "Go to block 7 on the circuit diagram"
PRINT "Locate T385 and test (V- ) pin 3 of T385 to B100"
PRINT "If T385 to B100 is good (otherwise replace it)"
PRINT "Locate diode D387 and test (V- ) pin 12 of T385 to 387"
PRINT "The fault is there! replace where necessary"
ELSE
PRINT "The voltage at pin 3 of B100 not greater than C > 150V"
PRINT "Go to block 7 on the circuit diagram"
PRINT "Locate T385 and test (V- ) pin 3 of B100 to pin 6 of T385"
PRINT "The fault is there! replace where necessary"
END IF
ELSE
PRINT "The voltage at pin 6 of B100 is not 80v"
PRINT "Locate resistor R 122 and test (V- ) pin 6 of B100 to R122"
PRINT "The fault is there! replace where necessary"
END IF
ELSE
PRINT "The voltage at point M8 is not 110V"
PRINT "Locate transistor TS272"
PRINT "The test (V- ) of TS 272"
PRINT "TS 272 is bad! replace"
END IF
ELSE
PRINT "There is no light in the filament of CRT tube B100"
PRINT "Go to block 7 on the circuit diagram"
PRINT "Locate plugs K5 and K6. Remove or unplug them."
PRINT "Go to block 5 on the circuit diagram"
PRINT "Test the resistance of pin 1 and pin 8 of tube B100"
PRINT "Go to block 7 on the circuit diagram"
PRINT "Locate plugs K5 and K6. Test the resistance of K5 to K6"
PRINT "The fault is either with the tube B100 plugs K5 and K6"
END IF
ELSE
PRINT "No brightness and No sound"
PRINT "Go to block 1 on the circuit diagram"
PRINT "Locate point + 110 and measure voltage at + 110"
INPUT "Is the voltage at + 110 (greater than) > 100V (Y/N)? : "; CHOICES$
IF CHOICES$ = "Y" THEN
PRINT "The voltage at point + 110 is (greater than) > 100V"
```

```
PRINT "Go to block 7 on the circuit diagram"
PRINT "Locate transistor TS 369 and measure voltage of the base"
INPUT "Is the voltage at the base TS 369 > - 1.5V (Y/N)?: "; CHOICES$
IF CHOICES$ = "Y" THEN
PRINT "The voltage at the base of TS 369 is > - 1.5V"
PRINT "Locate point + 180 and measure voltage at + 180"
INPUT "Is the voltage at + 180 equal 170V (Y/N)?: "; CHOICES$
IF CHOICES$ = "Y" THEN
PRINT "The voltage at + 180 is equal 170V"
PRINT "Locate transistor TS 375 and transformer T 385"
PRINT "Test (V- ) transistor TS 375 and T 385"
PRINT "The fault is there! replace where necessary"
ELSE
PRINT "The voltage at + 180 is not equal 170V"
PRINT "Locate transistor TS 369 and test (V- ) of TS 369"
PRINT "TS 369 is bad! replace"
END IF
ELSE
PRINT "The voltage at the base of TS 369 is not > - 1.5V"
PRINT "Locate diode D 358 and measure anode voltage of D 358"
INPUT "Is the voltage at the anode of D 358 equal 9V (Y/N)?: "; CHOICES$
IF CHOICES$ = "Y" THEN
PRINT "The voltage at the anode of D358 is 9V"
PRINT "Locate transistors TS 368 and TS 369"
PRINT "Test (V- ) transistors TS 368 and TS 369"
PRINT "The fault is there! replace where necessary"
ELSE
PRINT "The voltage at the anode of D 358 is not 9V"
PRINT "Locate transistors TS 358 and TS 359"
PRINT "Test (V- ) transistors TS 358 and TS 359"
PRINT "The fault is there! replace where necessary"
END IF
END IF
ELSE
PRINT "The voltage at point + 110 is less than < 100V"
PRINT "Locate plug p6 and measure voltage at p6"
INPUT "Is the voltage at plug p6 equal 135V (Y/N)?: "; CHOICES$
IF CHOICES$ = "Y" THEN
PRINT "The voltage at plus p6 is 135V"
PRINT "Locate VL 148 and measure resistance of VL 148"
PRINT "If 148 is good (otherwise replace, if bad)"
PRINT "Locate transistors TS 151, TS 156 and TS 157"
PRINT "Test (V- ) of transistors TS 151, TS 156 and 157"
PRINT "If the transistors are good (otherwise replace is necessary)"
PRINT "Go to block 7 on the circuit diagram"
PRINT "Locate diode D 389 and measure its resistance"
```

```

PRINT "D 389 is bad! replace"
ELSE
PRINT "The voltage at plug p6 is not 135V"
PRINT "Locate VL 140 and measure resistance of VL 140"
PRINT "If VL 140 is good (otherwise replace, if bad)"
PRINT "Locate SKI and plug p6"
PRINT "Test (V- ) of SK1 to plug p6"
PRINT "The fault is there ! replace where necessary"
END IF
END IF
ELSE
PRINT "The problem is not lack of brightness "
END IF
GOTO 1000

400  REM Program for the repairs of noisy picture
INPUT "Is the picture noisy (not very clear) Y/N)?: "; CHOICES$
IF CHOICES$ = "Y" THEN
PRINT "There is a noisy picture (not clear picture)"
PRINT "Go to block 5 on the circuit diagram"
PRINT "Locate CRT tube B100 and resistor R407"
PRINT "Test V-  of pin 4 of B100 ro R407"
PRINT "If the reading is good (else replace where necessary)"
PRINT "Bridge the focus control"
PRINT "The fault is there! replace"
ELSE
PRINT "problem is not a noisy picture"
END IF
GOTO 1000

500  REM Program for the repair of uncontrollable brightness
INPUT "Is the brightness uncontrollable (Y/N)?: "; CHOICES$
IF CHOICES$ = "Y" THEN
PRINT "The brightness is uncontrollable"
PRINT "Go to block 5 on the circuit diagram"
PRINT "Locate CRT tube B100 and resistor R122"
PRINT "Test (V-v) of pin 6 of B100 to R122"
PRINT "If the reading is good (otherwise replace any)"
PRINT "Locate diode D 123 and Test resistances"
PRINT "D123 is bad! replace"
ELSE
PRINT "fault is not an uncontrollable brightness"
END IF
GOTO 1000

450  REM Program for the repairs of wobbling pictures"
INPUT "Is it a problem of wobbling pictures (Y/N)?: "; CHOICES$
IF CHOICES$ = "Y" THEN

```

```

PRINT "Go to block 4 on the circuit diagram"
PRINT "Locate diode D 243 and D 247"
PRINT "Test the resistance of the diodes D 243 and D 247"
PRINT "If they are (or otherwise replace appropriately)"
PRINT "Locate M9 and measure voltages at M9 when:"
PRINT "The aerial is connected to get > 8V"
PRINT "The aerial is disconnected to get > 5.5V"
INPUT "Did you obtain correct voltage (Y/N)? "; CHOICES$
IF CHOICES$ = "Y" THEN
PRINT "Correct voltages are obtained"
PRINT "connect (Black) the aerial"
PRINT "Locate resistor R 241 and bridge it legs for steady picture"
PRINT "Unbridge the legs and locate diode D241"
PRINT "Test resistance of D241 (If good, otherwise replace)"
PRINT "Go to block 1 on the circuit diagram"
PRINT "Locate diode D143 and capacitors C148 and C150"
PRINT "Test D143 and shortness for C148 and C150"
PRINT "The fault is there! replacement is necessary"
ELSE
PRINT "Correct voltage are not obtained"
PRINT "Locate transistor TS 247"
PRINT "Test (V- ) transistor TS 247"
PRINT "TS 247 is bad! replace"
END IF
ELSE
PRINT "The fault is not a wobbling pictures"
END IF
GOTO 1000

```

550 REM Program for the Repair of Sound Problem

```

INPUT "Is the fault only with Sound/Audio output (Y/N)?"; CHOICES$
IF CHOICES$ = "Y" THEN
PRINT "The Problem is No Sound/Distorted Sound"
PRINT "Go to block 2 on the circuit diagram"
PRINT "Locate M3 and inject (half) point M3"
INPUT "Is there (normal) sound (Y/N)? "; CHOICES$
IF CHOICES$ = "Y" THEN
PRINT "There is (normal) sound when collector of TS 171 is injected"
PRINT "Inject the base of TS 171"
INPUT "Is there (normal) sound (Y/N)? "; CHOICES$
IF CHOICES$ = "Y" THEN
PRINT "There is (normal) sound when base of TS 171 is injected "
PRINT "Locate and Test (v- ) base of TS 171 to U175 in block 4"
PRINT "The fault is there ! replace where necessary"
ELSE
PRINT "No sound when base of TS 171 is injected"

```

```

PRINT "Test (v-) of Transistor TS 171. it is bad!"
END IF
ELSE
PRINT "No sound when collector of Ts 171 is injected"
PRINT "Test (v- ) collector of TS to poiny M3"
PRINT "The fault is there!"
END IF
ELSE
PRINT "No sound when point M3 is injected"
PRINT "Locate and inject base of transistor TS 185"
INPUT "Is there (normal) sound (Y/N)? : "; CHOICES$
IF CHOICES$ = "Y" THEN
PRINT "There is (normal) sound when base of TS 185 is injected"
PRINT "Test Resistance of MS to base of Ts 185"
PRINT "The fault is there!"
ELSE
PRINT "No normal sound when base of TS 1856 is injected"
PRINT "Locate Transistor TS 189 and measure its emitter voltage"
INPUT "Is there voltage there 11.8v (Y/N)? : "; CHOICES$
IF CHOICES$ = "Y" THEN
PRINT "THE voltageat the emitter of TS 189 is 11.8V"
PRINT "Locate and Test (v- ) of emitter TS 189 to S100 to plug RS"
PRINT "The Problem is there!"
ELSE
PRINT "The voltage at the emitter ofTS 189 is not 11.8"
PRINT "Locate and test the resistances of Resistors R194 and R196"
PRINT "Locate and test (v- ) of Transistors TS 185, Ts 189, Ts 192 & TS"
195"
PRINT "The problem is there!"
END IF
END IF
END IF
ELSE
PRINT "The fault is not (only) problem of sound"
END IF
GOTO 1000
600 REM Program for Repairs full and collapse picture (TO vertical
Line)
INPUT "Is the picture sometimes full and collapse (:Y/N)? : "; CHOICES$
IF CHOICES$ = "Y" THEN
PRINT "THEpicture on the screen somrtimes full and collapse tovert."
line"
PRINT " Go to block 8 onthe circuit diagram"
PRINT "Locate and Test (V- ) of diodes D 326, D 327and Resistor R 327"
PRINT "You may replace R327.It is b ad!"
ELSE

```

```
PRINT "The fault is not that of full and sometimes collapse picture"  
END IF  
GOTO 1000
```

```
650 REM Program for the Repair of Lack of Sync for both the REM  
Vertical and the Horizontal  
INPUT "Is there No Sync for both vertical and Horizontal (Y/N)?: ";  
CHOICES$  
IF CHOICES$ = "Y" THEN  
PRINT "There is no Sync for both the vertical and Horizontal Lines"  
PRINT "Goto block 6 on the circuit diagram"  
PRINT "Disconnect the aerial"  
PRINT "Locate Transistor TS264 and measure voltage at its collector"  
END IF  
INPUT "Is there voltage at the collector of Ts 264 equal 3.4v (Y/N)?: ";  
CHOICES$  
IF CHOICES$ = "Y" THEN  
PRINT "The voltage at the collector of TS 264 is 3.4v"  
PRINT "Locate and Test resistance of diode D 260"  
PRINT "If the diode is good"  
PRINT "Locate and Test (v- ) of Transistor TS 2342 "  
PRINT "If the diode D 260 is good then Transistor TS 232 is bad!"  
ELSE  
PRINT "The voltage at the collector of TS 264 is not 3.4v"  
PRINT "Test (v- ) of Transistor TS 264. It is bad!"  
ELSE  
PRINT "The problem is not lack of Sync for both Vertical & Horizontal"  
END IF  
GOTO 1000
```

```
700 REM Program for the repairs of lack of Horizontal Sync  
INPUT "Is the fault that of slanting picture (Lack of Horizontal Sync)  
(Y/N)?: "; CHOICE1  
IF CHOICES$ = "Y" THEN  
PRINT "There is lack of Horizontal Sync"  
PRINT "Goto block 4 on the circuit diagram"  
PRINT "Locate and measure voltage at point M9, when :"  
PRINT "1. The aerial is connected to obtain >8v"  
PRINT "2. The aerial is disconnected to obtain 6v"  
INPUT "Is the correct voltages of >8 & 6v obtained (Y/N)?:"; CHOICES$  
IF CHOICES$ = "Y" THEN  
PRINT "The correct voltages of >8v and 6v obtained"  
PRINT "Goto block 7 on the circuit diagram"  
PRINT "Locate diode D 344 and bridge its cathode to the ground"  
PRINT "Locate Resistor R 351 and Short its legs (bridge)"  
INPUT "Is the TV works fine (Y/N)?: "; CHOICES$
```

```

IF CHOICES$ = "Y" THEN
PRINT "The TV is okay when the legs are short"
PRINT "Disconnect/unbridge the diode D 344 (short to ground)"
INPUT "Does the TV works fine (Y/N)?: "; CHOICES$
IF CHOICES$ = "Y" THEN
PRINT "The TV works fine when the diode is unbridge"
PRINT "The TV does not work fine when diode is unbridge"
PRINT "Disconnect the aerial"
PRINT "Locate and Test (v- ) of diodes D 344 and D 345"
PRINT "Locate and Test resistance of resistors 350 and capacitor of C"
353 & C 354"
PRINT "If the components are good"
PRINT "Go to block 6 on the circuit diagram"
PRINT "Locate and Test (v- ) plug M1 to collector of Transistor is 232"
PRINT "The fault is there!"
END IF
ELSE
PRINT "The TV does not works fine when diode D 344 is unbridg"
PRINT "Locate and Test (v- ) Transistors Ts 358 and TS 359"
PRINT "The fault isthere!"
END IF
ELSE
PRINT "The correct voltage of >8 and 6v couldbe obtained"
PRINT "Locate and Test (v- ) TRansistor Ts 247"
PRINT "The transistor Ts 247 is bad!"
END IF
GOTO 1000
PRINT "The fault is not lack of HorizontalSync (Not slanting)"
END IF
GOTO 1000
750 REM Program for the repair oflack of vertical Sync (Rolling
Pic)
INPUT "Is it the problem of vertical Sync (Rolling Pictures) (Y/N)?: ";
CHOICES$
IF CHOICES$ = "Y" THEN
PRINT "The problem of vertical Sync (i.e. Rolling picture)"
PRINT "Goto block 8 on the circuit diagram"
PRINT "Locate and short (bridge) resistor R 328"
PRINT "Locate and Test voltages of Transformer T 304 and T 305"
PRINT "If the voltages is okay [otherwise bad transformer(s)]"
PRINT "Goto block 6 on the circuit diagram"
PRINT "Locate and Test (v- ) collector of TS 232 to base of TS 305"
PRINT "Locate Transistors TS 232 in block 6 and TS 305 in block 8"
PRINT "Test (v- ) collector of TS 232 to base of TS 305"
PRINT "the problem is there!"
ELSE

```

```

PRINT "The fault is not lack of vertical Sync"
END IF
GOTO 1000
800 REM Program for the Repair of No full picture on the screen
REM Vertical and Horizontal sides
INPUT "Is the picture not full on Vertical and Horizontal sides (Y/N)?:"; CHOICES$
IF CHOICES$ = "Y" THEN
PRINT "The picture of the screen is not full on both Vertical &"
Horizontal sides"
PRINT "Goto block 1 on the circuit diagram"
PRINT "Locate point M! amnd measure voltage when resistor R 161 is"
bridge ""
PRINT "Bridge the resistor R 161 voltage at M1 is 110v"
END IF
INPUT "Is the resistor R 161 bridged (Y?N)?:"; CHOICES$
IF CHOICES$ = "Y" THEN
PRINT "The resistor R 161 is bridged"
PRINT "Goto block 7 on the circuit diagram"
PRINT "Locate diode D 387 in block 7 and CRT tube B 100 in block 4"
PRINT "Test (v- ) diode D 387 to B 100"
PRINT "The problem is there!"
ELSE
PRINT "The resistor R 161 is not bridge (unbridge it)"
PRINT "Locate diode D 151 and Test resistance of D 151"
PRINT "If the diode is good"
PRINT "Locate Transistors TS 151, TS 156 and TS 157"
PRINT "Test V- of TS 151, TS 156 and TS 157"
PRINT "The problem is there!"
END IF
PRINT "The fault is not lack of full picture on the screen endif"
GOTO 1000
850 REM Program for the Repair of lack of full picture on the Rem
Horizontal sides
INPUT "Is the picture not full on the screen to the horizontal sides
(Y/N)?:"; CHOICES$
IF CHOICES$ = "Y" THEN
PRINT "The picture is not full on the Horizontal side of the screen"
PRINT "Goto block 8 on the circuit diagram"
PRINT "Locate resistors R 333/R334 and measure voltage (to get 13v)"
INPUT "Is the voltage at R 333/R/334 equal 13v (Y/N)?:"; CHOICES$
IF CHOICES$ = "Y" THEN
PRINT "The voltage at R 333/R/334 is 13v"
PRINT "Locate and bridge resistor R 320 to get full brightness on the"
TV ""
PRINT "Unbridge the resistor R 20"

```



```

PRINT "Locate and Test (v- ) plug L5 to capacitor C 313"
PRINT "If the reading is good (otherwise replace)"
PRINT "The problem is with the capacitor C 333!"
ELSE
PRINT "13v is not obtained in the resistor R 333/R 334"
PRINT "Locate and Test (v- ) Transistor TS 327, TS 333 and Ts 334"
PRINT "The problem is there! Replace where necessary"
END IF
ELSE
PRINT "The problem is not that of unfull picture on the Horizontal"
sides ""
END IF
GOTO 1000
900 REM Program for the Repair of frame collapse
REM No vertical deflection
INPUT "Is it the fault of frame collapse (Vertical deflection) (Y/N)?:"
"; CHOICES$
IF CHOICES$ = "Y" THEN
PRINT "The fault is frame collapse i.e. No vertical deflection"
PRINT "Goto block 1 on the circuit diagram"
PRINT "Locate and measure voltage at point +30 (to get 30v)"
END IF
INPUT "Is the voltage there m30v (Y/N)?:" "; CHOICES$
IF CHOICES$ = "Y" THEN
PRINT "The voltage at point +30 is 30V"
PRINT "Goto block 8 on the circuit diagram"
PRINT "Locate and measure voltage of resistor R 333/R 334"
INPUT "Is 13v obtainable from R 333/R 334"; CHOICES$
IF CHOICES$ = "Y" THEN
PRINT "Voltage at R 333/R 334 is 13v"
PRINT "Locate Transistor TS 305 and measure ,the base voltage"
INPUT "Did you get -4v at the base of TS 305"; CHOICES$
IF CHOICES$ = "Y" THEN
PRINT "There is -4v at the base of Transistor TS 305"
IF CHOICES$ = "Y" THEN
PRINT " Locate and Test (v- ) capacitor C 337 to Resistor R 339"
PRINT "The fault is there!"
ELSE
PRINT "Voltage at the base of Transistor Ts 305 is not -4v"
PRINT "The fault is there!"
END IF
ELSE
PRINT "The voltage at resistor R 333/R 334 is not 13v "
PRINT "Locate and Test (v- ) Transistors TS 327, TS 333 and Ts 334"
PRINT "The fault is there!"
END IF

```

```
ELSE
PRINT "The voltage point +30 is not 30v"
PRINT "Locate point +30 in block 1 and TRansformer T 385 in block 7"
PRINT "Test (v- ) point +30 to Transformer T 385"
PRINT "The fault is there! Replace where necessary"
END IF
ELSE
PRINT "It is not the problem of frame collapse"
PRINT "It is not Vertical deflection problem"
END IF
GOTO 1000
950  REM Program for the Repair of Vertical height deflection
REM Problem
INPUT "Is there no Vertical height deflection (Y/N)?: "; CHOICES$
IF CHOICES$ = "Y" THEN
PRINT "There is no vertical height deflection"
PRINT "Goto block 8 on the circuit diagram"
PRINT "Locate and bridge resistor R 319 (legs)"
PRINT "The TV works fine"
PRINT "disconnect the shorted legs of resistor R 319 i.e. unbridge"
PRINT "Locate and Test resistors R 317 and R 319 and capacitor C 317"
PRINT "The fault is there! replace where necessary"
ELSE
PRINT "The fault is not problem of Vertical height deflection"
END IF
GOTO 1000
999  REM Program for the Repair of lack of Vertical linearity
REM deflection
INPUT "Is there Vertical linearity deflection (Y/N)?: "; CHOICES$
IF CHOICES$ = "Y" THEN
PRINT "There is no Vertical linearity deflection"
PRINT "Goto block 8 on the circuit diagram"
PRINT "Locate and Test (v- ) of resistor R 337 and diode D 337"
PRINT "If the components are okay"
PRINT "Locate and Test resistance of plug M2"
PRINT "If the Plug M2 is good"
PRINT "Goto block 5 on the circuit diagram"
PRINT "LOcate and Test resistance of Plug S9"
PRINT "Locate and Test (v- ) TRansistor TS 272"
PRINT "Transistor TS 272 is bad!"
ELSE
PRINT "The fault is not lack of Vertical linearity deflection"
END IF
1000  RETURN
End
```