

**Research/Technical Note**

# Learning of Embedded System Design, Simulation and Implementation: A Technical Approach

**Lukman Adewale Ajao, James Agajo, Jonathan Gana Kolo, Mutiu Adesina Adegboye, Yakubu Yusuf**

Department of Computer Engineering, Federal University of Technology, Minna, Nigeria

**Email address**

ajao.wale@futminna.edu.ng (L. A. Ajao), james.agajo@futminna.edu.ng (J. Agajo), jgkolo@futminna.edu.ng (J. G. Kolo), adegboiyemutiu@yahoo.com (M. A. Adesina), yusyak2008@yahoo.com (Y. Yusuf)

**To cite this article:**

Lukman Adewale Ajao, James Agajo, Jonathan Gana Kolo, Mutiu Adesina Adegboye, Yakubu Yusuf. Learning of Embedded System Design, Simulation and Implementation: A Technical Approach. *American Journal of Embedded Systems and Applications*. Vol. 3, No. 3, 2016, pp. 35-42. doi: 10.11648/j.ajes.20150303.12

**Received:** December 30, 2015; **Accepted:** January 21, 2016; **Published:** May 11, 2016

---

**Abstract:** Learning embedded system design, simulation and implementation opens a new paradigm in developing practical laboratory experiments for embedded based systems. This paper showcases method of learning system circuit design with the use of simulation computer aided design tools like proteus virtual system modelling (PVSM), multism and Tiny CAD. In order to demonstrate this procedure on how virtual microcontroller-based circuit experiments were carried out in the laboratory, PIC16F887 chip was used as the major logic component. Several practical on hands-experiment were demonstrated with the aid of PVSM, and the result of each experiment performed were displayed with snapshot. Although, the intent of this paper is to put forward a technical approach for learning and engaged students in practices, expert in the progression of learning embedded system courses. This hands-on experiment will be an added advantage besides the class room teaching of students, and allows hobbyist, professional scientist and engineers to design and analyze the system design before building a prototype on learning breadboard and before ever making final packaging.

**Keywords:** Embedded System, Simulation, Microcontroller, Paradigm, Snapshot

---

## 1. Introduction

Gobally, students tend to be less intrested in courses involving embedded systems, due to the less technical and practical experience they have gotten over the years. The limited experts in embedded systems as well has inadequate resources such as the hardware and software development tools which account for the loss of interest. In spite of these difficulties, today student can step into the area of embedded systems by (learn-while doing) undertaking certain simple in-house experiments with frequent practices on microcontroller-based electronics circuit design and simulation using Computer Aided Design (CAD) Tools such as the Proteus Virtual System Modelling (PVSM), multism, TinyCAD, Hamburg Design System (HADES), Quite Universal Circuit Simulator (QUCS), FidoCadJ tools [1,9]. However, it is pertinent that beginners and young desingers can

adopts a step by step or bottom to top approach of learning, which would ease the learning and understanding of simple embedded system design [2-4].

PVSM is an innovative design and simulation software tool for science and engineering professional. The PVSM, likewise other tools of its kind are very versatile and robust in nature for automated circuit designs [5]. The versatility of this tool tends beyond the use for only simulation but also aids the testing and troubleshooting of the circuitry at various stages/level of development for learning while doing laboratories exercises for advanced purposes. This tool (PVSM) is suitable for the applications of engineering electronics circuit design in the “learn-while doing” laboratory exercises in the courses like embedded system, microprocessor and microcontroller system, control engineering and digital system.

The application of these CAD software tools in the engineering and technical design would facilitate the

development of young designers and engineers, thus ensuring creativity, new ideas, ingenuity and inspiring wonderful designs as designers would find it easy to test their design, study the behaviour of circuit and analyse the design of simple circuit to advance and complex circuit development. Also, it will help to identify and eliminate fault at early stage of design, adjust on design incorrectness before the final product development [6-8].

Lastly, teaching students in these courses in a conventional way is inefficient and insufficient when the teaching techniques focus only on the theoretical aspects without putting hand-on laboratory experiment into the practices [10]. Focusing on the student training with active involvement during hands-on-laboratory at the entry level of embedded system course will give multiple advantages beside the theoretical knowledge and provide students with reasoning that associates their imaginary knowledge to hands-on experience [11-13]. Also, it gives a scope to modern teaching practices, international project collaboration, and cooperative learning processes [14].

Moreover, The microcontroller-based circuit designs and CAD tool application would not only help to introduce the use of the PVSM to the young and interested students but also serve as a guide for some specific and advanced projects which improve the teaching and learning techniques of embedded systems.

In lieu of the above reasons, we intend to review the application of CAD tools specifically with respect to PIC16F887 microcontroller chip as a simple embedded systems design. This paper was thoughtful in sections. Section 1 discusses the review of related works as it applies to the subject matters. In section 2, we present a procedure for learning circuit design, development and implementation. While section 3 describe software development and simulation using PVSM with respect to PIC16F887 Microcontrollers. Furthermore, section 4 illustrates different projects on learn-while doing laboratory experiments and finally, Section 6 concludes the paper.

## 2. Related Work

Based on design tools, technicality for teaching embedded system and circuit development been presented as in [1], a project-based microcontroller system laboratory using BK300 development board with PIC16F887. This work was discusses how microcontroller chip could be programmed using a development board with PIC16F887, and numbers of experiment was carried out from the software based development to the hardware configuration. Therefore, the technical methods or approach for learning microcontroller based/embedded system courses was not highlighted, and already made PIC development kit was used to demonstrate each hands-on laboratory exercises.

A modular design and adoption of embedded system courseware with portable labs in a box was presented by author in [6]. This courseware emphasize the balance between theoretical foundations and technical practices of embedded

software development. Each courseware modular include lecture notes, review questions, assignments, and real hands-on laboratory based on the portable palm-size MCU development kit. But, the author did not work on technicality for system circuit design and simulation, breadboarding and others hardware development with hands-on laboratory experiments.

Universal learning system for embedded system education and promotion was put forward by [16]. Three hardware platforms design with different features was implemented for embedded system curriculums. The hardware platforms are imported into the universal learning system, so that students can use the proposed system to understand the relationship between the user preference and other feature vectors. Once a student decides which of the hardware platform according to the preference should be taken. Then, the course can be taken in either the CIC classroom or virtual classroom. This research limited to the curriculum design for learning embedded system and virtual classroom exercises with the applications of different hardware platforms. One on one hands-on laboratory exercise was not considered or suggested in the paper as a method for learning technicality in embedded system.

Author in [17], described embedded systems pedagogical issue: teaching approaches, students' readiness, and design challenges. This work explains the importance of teaching embedded systems courses in a way that can shrink the gap between academically taught skills and the skills sought after by the industry. They identifies that teaching of embedded system is a great challenging because is an interdisciplinary relationship, limited time, large variations of students motivations, skills, and backgrounds. In their opinion, they suggested that teaching an embedded system course should be majorly on hands-on laboratory exercises, which will significantly increase the teaching efficiency in this field. Unfortunately, no hands-on laboratory experiments was demonstrated either in a virtual system or hardware platform to show sample cases.

Therefore, author in [18] contributed that in spite of divergences in the course of learning embedded system, the goal is to teach a common set of topics to allow the student to interact with devices in the laboratory at both the software and hardware levels. Although, the author opinion is similar to the suggestions in [16].

Moreover, Our proposed developed system and illustrations attempts to offer a practical and technical clarification to the shortcoming and suggestion from the related works as earlier mentioned in [1, 6, 16, 17 & 18]. This work make apparent practicality by exhibiting the teaching approach "learn-while doing" on the embedded system projects, which will helps student connect their theoretical and practical knowledge, reasoning with hands-on laboratory practices of embedded system and other related courses. The learning approach adopt in this paper are bottom-up techniques. That is, embedded system design, development and implementation could be learn by circuit design and simulation style, breadboarding process, and soldering before ever making the final packaging of the systems.

### 3. Methods for Learning Design of Embedded System with Implementation

The methods adopt in this paper for learning the design, simulation, and implementation of a simple and advance

embedded system projects are technically categorized into the followings and is depicted sequentially in the figure 1 as a modular approach to the learning aide.

- Circuit design and simulation (Using PVSM)
- System circuit demonstration (Breadboarding)
- Circuit implementation (Soldering)
- Packaging

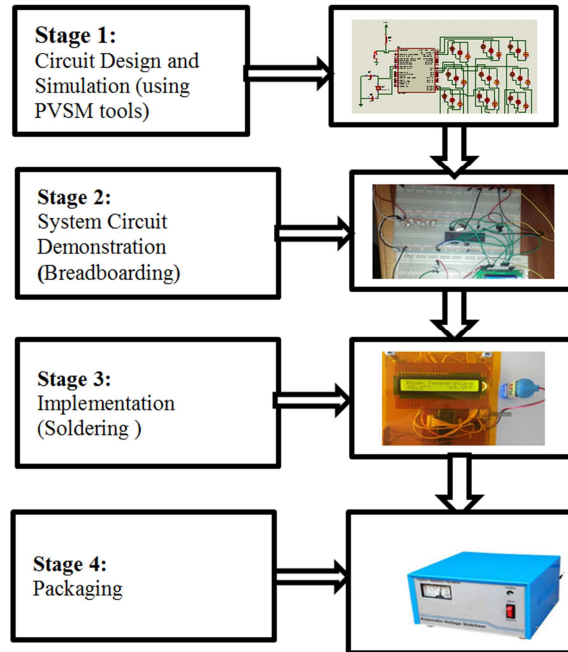

Figure 1. Block diagram of learning embedded system circuit design and implementation.

#### 3.1. Circuit Design and Simulation Platform

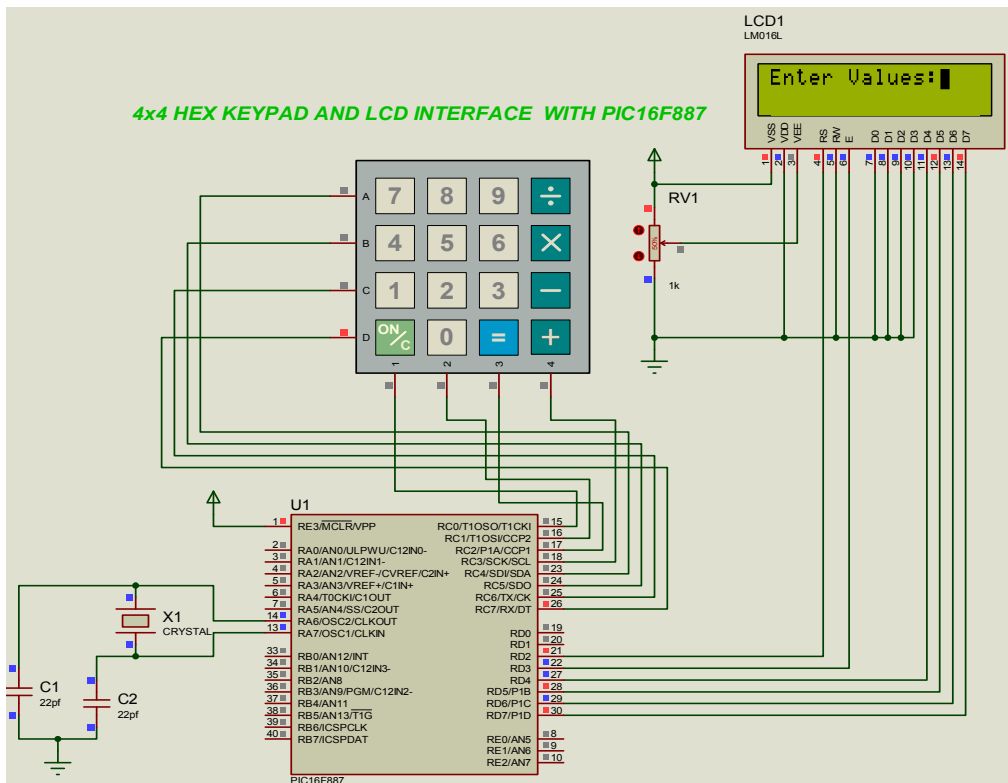

Figure 2. Simulated diagram of the system circuit design.

Circuit design and simulation is categorise as the first stage of learning embedded system development, where semiconductor technology were arranged and linked together with electric path way. That is, by assemble all the electronics components entail in the design into the schematic editing window of PVSM with the aid of virtual electrical wire. Then, the compiled code (.hex file) were loaded on the microcontroller chip for the simulation process as shown in the figure 2.

**3.2. System Circuit Demonstration Platform (Breadboarding)**

System circuit demonstration (breadboarding) was considered as second stages of learning technical in embedded system design in this paper. This is the process by which electronic circuit is building solderless or a construction of solderless base for prototyping of electronics in a real life activities. While the electronics system circuit was designed and simulated as shown in the figure 2, the prototype will now be replicated into the breadboard modules using jumper wire for the connections. After the pattern of stage one has been completed on the board perfectly, connect the power to the breadboard and observe similar behaviour as computer generated work shown in the figure 3.

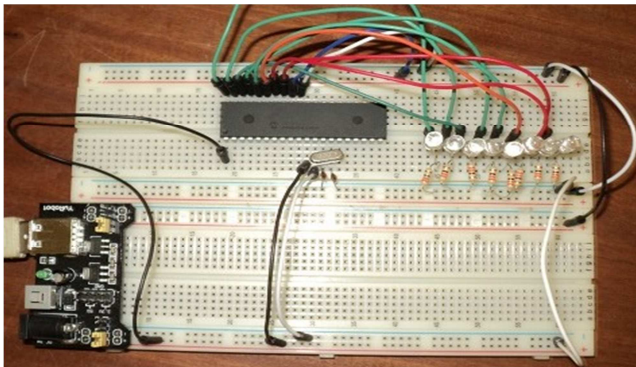

Figure 3. Snapshot of system circuit on the breadboard.

**3.3. System Circuit Implementation Platforms (Soldering)**

The system circuit implementation was highlighted as stage three for the effective learning of embedded system development based on the author research and experiences. This phase is where joining of metals by a fusion of alloys which have relatively low melting points known as soldering come to the existence. In this segment, skills acquired during the first and second platform exercises were merged together (simulation and breadboarding) to produce real world embedded system by soldering all the electronics and electrical wire together to functions as a unit on a vero board or printed circuit board as presented in the figure 4.

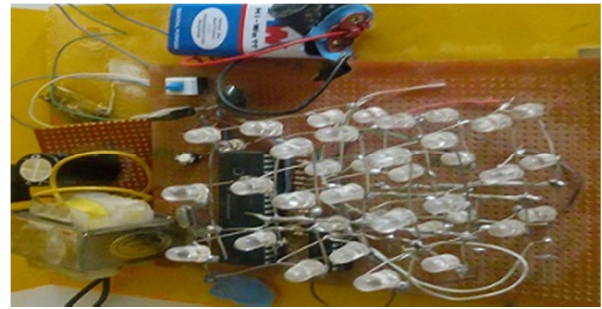

Figure 4. Snapshot of system circuit implementation on the vero board.

**3.4. System Packaging Platform**

The system packaging is categorized as the final phase in the course of learning and development of embedded system circuit. This stage refer to the technology put together to enclosing or protecting products for the distribution, storage, sale, and domestic usage.



Figure 5. Snapshot of embedded system packaging.

**4. Description of Program Design and Simulation Using PVSM with PIC16F887**

The mikro C language and PVSM was used for the programming and simulation respectively for sequence of developing and exhibit simple embedded system on hands-on laboratory project. The procedure for software design and computer-generated output of embedded system projects are depicted with the block diagram shown in the figure 6, and the internal architecture of PIC16F887 firmware is depicted in figure 7 respectively.

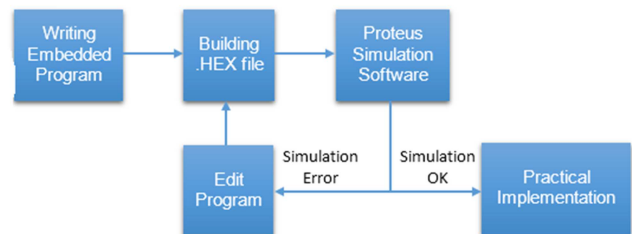

Figure 6. Block diagram of programming and simulation of system circuit design.

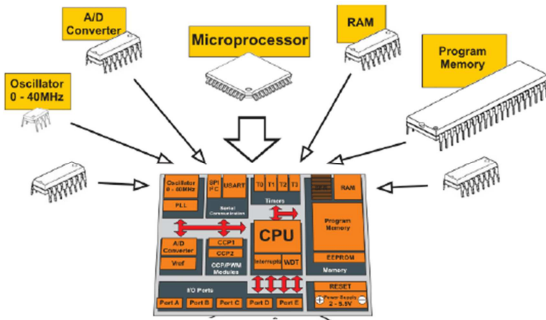



Figure 7. Internal Architecture of PIC16F887 microcontroller firmware.

**4.1. Procedure for the Circuit Design and Simulation Using PVSM with PIC16F887**

1. Double click the Proteus ICON  to load and start the application

2. Click on Proteus ISIS Schematic Capture  to open.
3. Click On P to select the Component (Pick From Libraries).
4. Add all the required components for the circuit diagram.
5. Place the components on the workspace.
6. Wire up the circuit diagram.
7. Connect all the terminals to the circuit diagram (power and ground).
8. Set Memory clear pin to high if contained microcontroller unit.
9. Set clock frequency to PIC MCU in Proteus.
10. Load .hex file to the schematic diagram of PIC MCU.
11. Click on Play Button on the bottom left of editing window to start simulation of the system circuit design as presented in the figure 7 below.

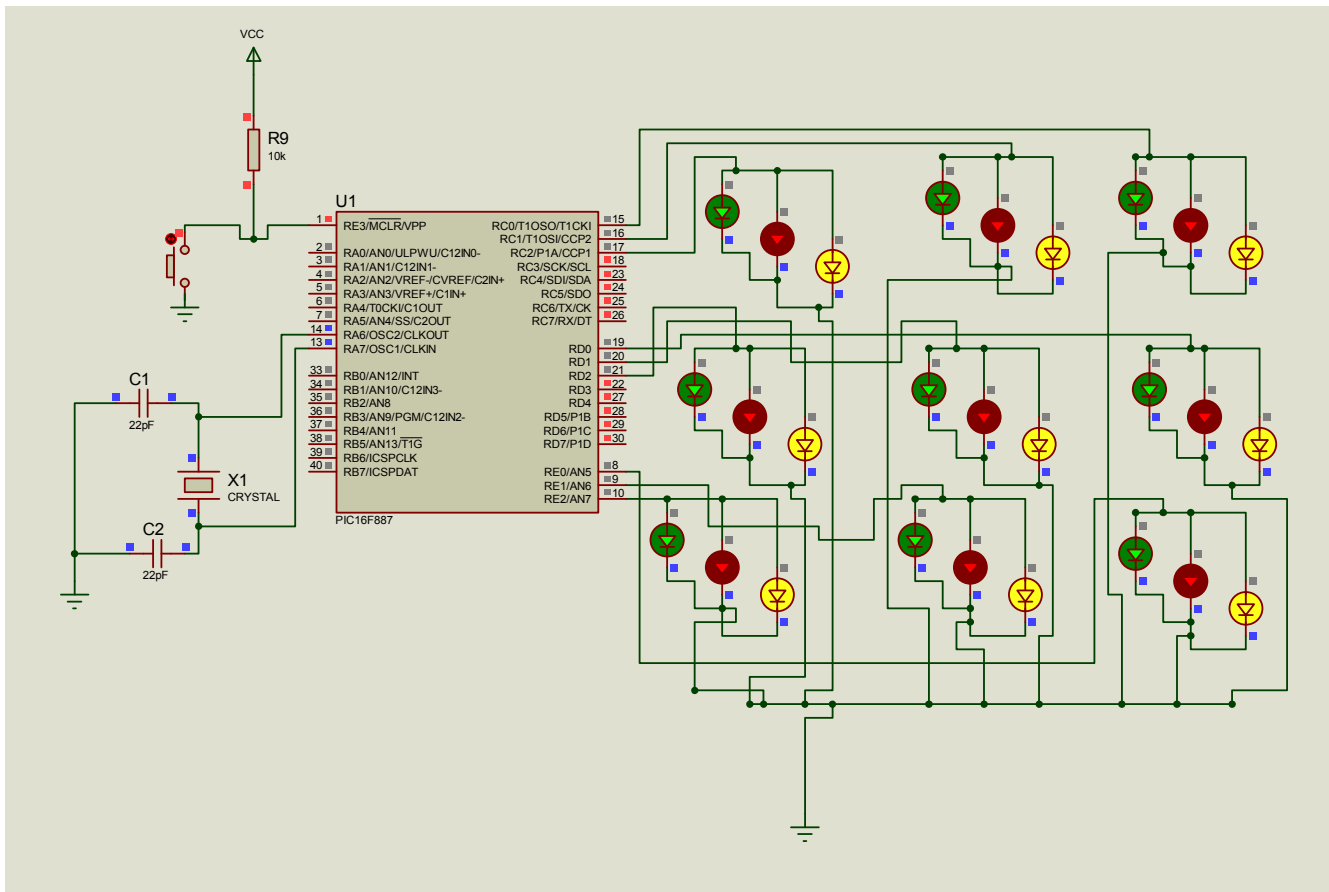

Figure 8. Simulated circuit design in PVSM frame.

**4.2. Simple Program Design for LED Blink (ON/OFF)**

```

/* The Header
Name:AjaoLukmanAdewale
Dept:Computer Engineering
Date:10/12/2015
Title: LED Blink (ON/OFF)
*/
void main() {

```

```

TRISC=0; // Configures Port C as output port
while(1){ // Show the output value continuously
PortC=0xFF;// Assigns PortC pins with this values
Delay_ms(2000); //Delay functions, for 2seconds
PortC=0x00; // Assigns PortC pins with this values
Delay_ms(2000); //Delay functions, for 2seconds
}
}

```

## 5. Details of Individual Hands-on Laboratory Experiments

The details of different “learn-while-doing” system design and development presented in this paper focuses on expert in the intention of embedded system projects during laboratory exercises, using solderless breadboard for the demonstration and veroboard or PCB for the implementation of real life virtual circuit experimentations. The followings are the simple embedded system projects design and implemented.

1. LED chasing and 3x3x3 LED Cube
2. LCD module display message
3. Microcontroller-based digital thermometer
4. 7-segment display countdown timer
5. Analog-digital converter (ADC) module.

### 5.1. Hands-on Laboratory 1: LED Chasing and 3x3x3 LED Cube

Hands-on laboratory experiment described in this section was to illustrate how simple light emitting diode could be interfaced with PIC16F887 microcontroller with simple lines of program code to perform ON/OFF or blink functions as demonstrated in the figure 9a, and also 3x3x3 LED cube was demonstrated in figure 9b.

The followings are the significant components used for this hands-on laboratory exercise in a real life circuit design. Breadboard, Vero board, 9Volts battery, 5Volts PSU, Jumper connector wires, PIC16F887 chip, LED, Crystal oscillator (4MHz), electrolytic capacitor (22Pf), Resistor (220Ω).

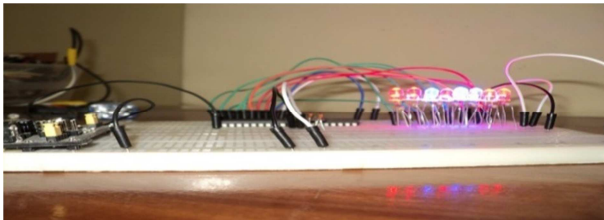

Figure 9a. Snapshot of led blink arranged on a breadboard.



Figure 9b. Snapshot of 3x3x3 LED cube chasing soldered on a veroboard.

### 5.2. Hands-on Laboratory 2: LCD Module Message Display

In this experiment, 2x16 liquid crystal display (LCD)

module was interfaced with PIC16F887 chip and program with few lines of code to display alphabetic messages as demonstrated in the figure 9. The following are the components used in the design and construction of LCD module message display. Breadboard, 5Volts Power supply unit, Jumper connector wires, PIC16F887 chip, Crystal oscillator (4MHz), electrolytic capacitor (22Pf), LED, 2x16 LCD module, Variable resistor (1KΩ). Ensure that proper connection is done; ground and 5v power is connected to the board. Wait to observe the output message on the screen.

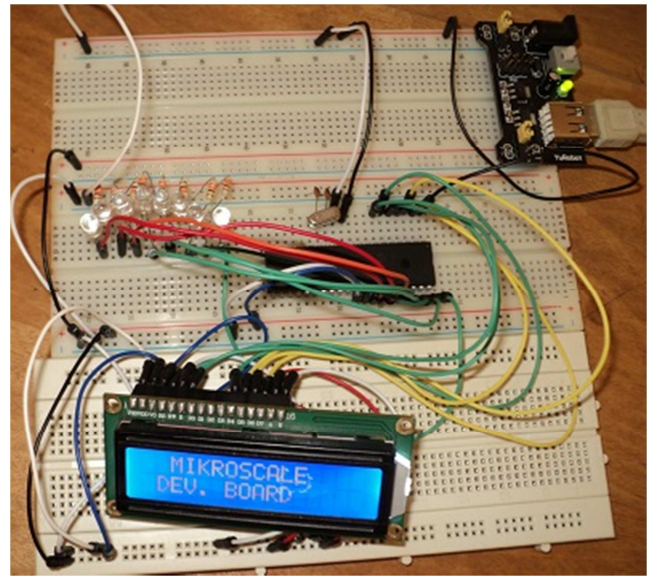

Figure 10. Snapshot of LCD module interfacing with PIC16F887 microcontroller.

### 5.3. Hands-on Laboratory 3: Microcontroller-Based Digital Thermometer

Embedded system project-based 3 described in this paper was on microcontroller-based digital thermometer. This section hands-on laboratory exercise educate students and any interested learner on how to interfaces different components such as temperature sensor, LCD, and LED with a single microcontroller chip to accomplish a looked-for control system. Also, this experiment “microcontroller-based digital thermometer” was developed to enhance the students skills on how to implement two or more digital I/O components with a controller in an embedded system design.

Microcontroller-based digital thermometer was developed and programmed to measure the actual room temperature and display the measure value in digital form i.e (°C & °F) using LM35 temperature sensor. This project hands-on laboratory exercise include Breadboard, 5Volts PSU, Jumper connector wires, PIC16F887 chip, Crystal oscillator (4MHz), electrolytic capacitor (22Pf), 2x16 LCD module, Variable resistor (1KΩ) and LM35 temperature sensor. This experiment was conducted and the hardware design is demonstrated on the powered breadboard as shown in the figure 10.



the semester laboratory works, and definitely gives confidence to every students by embark on a complex design of any embedded system projects. Finally, this work is looked-for further research on the design and development in the field of study FPGA- based embedded system and ATmega microcontroller based system.

---

## References

- [1] Lukman A. Ajao, Olayemi M. Olaniyi, Jonathan G. Kolo, Abdulazeez O. Ajao, "Project-Based Microcontroller System Laboratory Using Bk300 Development Board With PIC16F887 Chip", *International Journal of Embedded Systems and Applications (ijesa)* Vol.5, No.3, September 2015, doi: 10.5121/ijesa.2015.5302.
- [2] Xiaolin Hu, Minghao Wang, Yuanfeng Xu, Kai Qian, "Modular Design and Adoption of Embedded Systems Courseware with Portable Labs in a Box", *Proceedings of the World Congress on Engineering and Computer Science (WCECS 2012)* Vol.1, October 24-26, 2012.
- [3] Kai Qian, Xiaolin Hu, Liang Hung, "Experience on Teaching Multiple CS Courses with Portable Embedded System Labware in a Box", *Proceedings of the World Congress on Engineering and Computer Science (WCECS 2011)*, Vol. I, San Fransisco, USA, Oct. 19-21, 2011.
- [4] Zalewski, J., "A Comprehensive Embedded Systems Lab for Teaching Web-Based Remote Software Development", 23<sup>rd</sup> IEEE Conference On Software Engineering Education and Training, Pittsburgh, PA, March 9-12, 2010.
- [5] [http://www.labcenter.com/products/pcb/schematic\\_libraries.cfm](http://www.labcenter.com/products/pcb/schematic_libraries.cfm)
- [6] Naveen Kumar Uttarkar, Raghavendra Rao Kanchi. "Design and Development of a Low-Cost Embedded System Laboratory Using TI\ MSP430 LaunchPad", *American Journal of Embedded Systems and Applications*. Vol. 1, No. 2, 2013, pp. 37-45. doi: 10.11648/j.ajesa.20130102.12
- [7] Lee, Chyi-Shyong, Su, Juing-Huei, Kuo-En Lin, Jia-Hao Chang, Gu-Hong Lin, (2010) "A Project-Based Laboratory for Learning Embedded System Design With Industry Support Education", *IEEE Transactions on*, vol.53, no.2, pp.173,181, May 2010 doi: 10.1109/TE.2008.2010990
- [8] <http://www.edac.org/industry>.
- [9] <http://www.bie.org> Buck Institute for Education, 18 Commercial Blvd, Novato, CA 94949. (415) 883-0122).
- [10] Aruna Kommu, Raghavendra Rao Kanchi. "Design and Development of a Project-Based Embedded System Laboratory Using LPC1768", *American Journal of Embedded Systems and Applications*. Vol. 1, No. 2, 2013, pp. 46-53. doi: 10.11648/j.ajesa.20130102.13
- [11] Siddiqui A., Khan M., Akhtar S., "Supply chain simulator: A scenario-based educational tool to enhance student learning," *Computers & Education*, vol. 51, pp. 252–261, 2008.
- [12] Yehezkel C., Yurcik W., Pearson M. and Armstrong D., "Three Simulator Tools for Teaching Computer Architecture: EasyCPU, Little Man Computer, and RTLsim," *ACM Journal of Educational Resources in Computing*, Vol. 1(4), pp. 60-80, 2001.
- [13] Davcev D., Stojkoska B., Kalajdziski S., and Trivodaliev K., "Project Based learning of embedded systems", in *Proceedings of the 2nd WSEAS Telecommunications*, 2008.
- [14] Nooshabadi S. and Garside J., "Modernization of teaching in Embedded Systems design—An international collaborative Project", *IEEE Transactions on Education*, vol. 49, no. 2, pp. 254-262, May, 2006.
- [15] J. W. Bruce, J. C. Harden, and R. B. Reese, "Cooperative and Progressive design experience for embedded systems", *IEEE Transactions on Education*, vol.47, no.1, pp.83-92, Feb. 2004.
- [16] Kai-Chao Yang, Yu-Tsang Chang, Chien-Ming Wu, Chun-Ming Huang, and Chin-Long Wey "Universal Learning System for Embedded System Education and Promotion", *International Journal of Advanced Computer Science and Applications*, Vol. 4, No. 2, 2013.
- [17] Intisar Ibrahim, Rosmah Ali, Mohamad Zulkefli, Nazar Elfadil. "Embedded Systems Pedagogical Issue: Teaching Approaches, Students Readiness, and Design Challenges". *American Journal of Embedded Systems and Applications*. Vol. 3, No. 1, 2015, pp. 110. doi:10.11648/j.ajesa.20150301.11.
- [18] Mitali A. et.al. "A Survey on Impact of Embedded System on Teaching". *MIT International Journal of Electronics and Communication Engineering* Vol. 3, No. 1, Jan. 2013, pp. 36–38.