

**AUTOMATIC RADIO SELECTION FOR DATA TRANSFER IN DEVICE-TO-
DEVICE COMMUNICATION**

BY

**IGBOKWE Chihirameze Ephrem
MENG/SEET/2017/7444**

**DEPARTMENT OF TELECOMMUNICATION ENGINEERING
SCHOOL OF ELECTRICAL ENGINEERING AND TECHNOLOGY
FEDERAL UNIVERSITY OF TECHNOLOGY MINNA.**

OCTOBER, 2021.

ABSTRACT

As technology evolves in telecommunication, the choice of the kind of radio to be used for data transfer in a multi-radio system at a particular time remains a challenge, especially in device-to-device (D2D) communications. This is evident in devices such as phones where multiple radio systems such as Bluetooth, Wireless Fidelity (WiFi), and Global System for Mobile communication (GSM) are present. Despite all these radios in place, the selection of these radios has always been done manually by users which introduces delay and increase in power consumption on the device. To mitigate this, there is a need for D2D to be able to automatically select radio for data transfer based on certain criteria. One of such criteria remains area of coverage as different radios have different ranges of coverage areas. To this end, this research presents automatic radio selection for data transfer for D2D. This was used via the use of a Geo-Position Service (GPS) module, Bluetooth device, Long range (LoRa) module, and an Arduino Nano. At the end of the research, the radio selection was possible and amount of energy consumed by the device within the period of twenty-four hours was 10%.

TABLE OF CONTENTS

Cover Page	i
Title Page	ii
Declaration	iii
Certification	iv
Acknowledgement	v
Abstract	vi
Table of Contents	vii
List of Tables	x
List of Figures	xi
Abbreviation	xiii
CHAPTER ONE	
1.0 INTRODUCTION	1
1.1 Background to the Study	1
1.2 Device to Device Application	2
1.2.1 Data transfer	2
1.2.2 Internet of Things (IoT)	2
1.2.3 Emergency communication	3
1.3 Architecture of D2D Communication	3
1.3.1 Device relaying with based station-controlled link formation	3
1.3.2 Direct D2D communication with based station Controlled link formation	4
1.3.3 Device relaying with device-controlled link formation	5
1.3.4 Direct D2D communication with device-controlled link formation	6

1.4	Statement of the Research Problem	9
1.5	Aim and Objectives of the Study	9
1.6	Justification of the Research	10
1.7	Scope of the Study	10
1.8	Thesis Outline	10
CHAPTER TWO		
2.0	LITERATURE REVIEW	11
2.1	D2D Discovery and Controls using Bluetooth	11
2.2	LTE D2D Discovery	12
2.3	WiFi D2D Discovery	15
2.4	LoRa D2D Discovery	18
CHAPTER THREE		
3.0	RESEARCH METHODOLOGY	22
3.1	Materials	22
3.1.1	Software	22
3.1.2	Hardware	22
3.3	Network Scenarios	23
3.4	Hardware Design	25
3.4.1	Power Supply	26
3.4.2	Controller	27
3.4.3	Display	28
3.4.4	Sensor	29
3.4.5	Multiplexer	29
3.4.6	LoRa Radio	30
3.4.7	Bluetooth	31

3.4.8	Distance measurement via GPS module	32
3.4.9	Communication pattern between the two devices	34
CHAPTER FOUR		
4.0	RESULTS AND DISCUSSION	36
4.1	Result for delay	36
4.2	Result for energy consumption	38
4.3	Result for radio selection	39
4.4	Comparison of result	43
CHAPTER FIVE		
5.0	CONCLUSION AND RECOMENDATIONS	44
5.1	Conclusion	44
5.2	Recommendations	44
5.3	Contribution to Knowledge	44
	REFERENCES	45

LIST OF TABLES

Table	Page
2.1 Comparison between the various techniques	21
4.1 Time of operation on the deployed automated device	36
4.2 Time of operation on a manually controlled smartphone	36
4.3 Energy consumption of the deployed D2D against time.	39
4.4 Error in Distance and Error in selection on a bright day	40
4.5 Error in Distance and Error in selection on a cloudy day	40

LIST OF FIGURES

Figure		Page
1.1	Device relaying with base station-controlled link formation	4
1.2	Direct D2D communication with based station controlled link formation	5
1.3	Device relaying with device-controlled link formation	6
1.4	Direct D2D communication with device-controlled link formation	7
2.1	Mobile Crowd Sensing (MCS) feature into smart devices to achieve device discovery	14
2.2	Design of the User Interface for a Smart Home Based on the Principles of WiFi Technology	16
2.3	Two types of ProSe-assisted relay D2D discovery mechanism	17
2.4	Tracking and monitoring system for mental disorder patients based on LoRa technology	18
2.5	The Experiment Environment on an Object tracking system	20
3.1	Flowchart of the system	23
3.2	Network Scenario for distance <10metres	24
3.3	Network Scenario for distance >10metres	25
3.4	Architecture of the system	26
3.5	Circuit diagram of the power supply	27
3.6	Arduino Nano pinout diagram	28
3.7	LCD 1602	28
3.8	Circuit diagram of a switch interfaced with the controller	29
3.9	Circuit diagram of the multiplexer interfaced with the system	30
3.10	Circuit diagram of the system interfaced with LoRa.	31

3.11	Circuit diagram of the system interfaced with the Bluetooth radio	32
3.12	Complete circuit diagram of the system	33
3.13	Assembled hardware component of the automatic radio selection system	34
3.14	Timing diagram illustrating the communication of the system	35
4.1	Energy consumption of the Deployed D2D	38
4.2	Graphical representation of trials on a bright day	42
4.3	Graphical representation of trials on a cloudy day	42
4.4	Energy consumption of Bluetooth, WiFi, LoRa and LoRa/Bluetooth	43

ABBREVIATIONS

Acronyms	Meaning
3GPP	Third Generation Partnership Project
ACK	Acknowledgement
ADC	Analog, Digital Converter
BIPS	Bluetooth Indoor Positioning Service
BLE	Bluetooth Low-Energy
BS	Base Station
CTS	Clear to Send Base Station
D2D	Device-to-Device
FDAF	Full Duplex Amplify and Forward
GPS	Geo position Service
HD	High Definition
IoT	Internet of Things
IoV	Internet of Vehicles
ISM band	Industrial, Scientific and Medical band
LCD	Liquid Crystal Display
LoRa	Long Range
LoRaWAN	Long Range Wide Area Network
LPWA	Low-Power Wide Area
LTE	Long Term Evolution
MCS	Mobile Crowd Sensing
ProSe	Proximity-based Service
QoS	Quality of Service

RNs	Relay Nodes
RTS	Request to Send
SAS	Short Authentication String
TA	Timing Advance
UART	Universal Asynchronous Receiver Transmitter
V2V	Vehicle-to-Vehicle
WiFi	Wireless Fidelity

CHAPTER ONE

1.0

INTRODUCTION

1.1 Background to the Study

Device to Device (D2D) communication is a paradigm that describes a technology that is used in the trending 5G cellular network. D2D communication is a technology that enables the communication between multiple devices with or without the need of the Base Station (BS), which reduces energy consumption for devices, increasing spectrum efficiency and offload traffic from the BS. The major reason for incorporating D2D communication in cellular networks is to explore the proximity of devices when engaged in local communication sessions such as media sharing, proximity-based services, and social networking (Das, 2015). D2D communication is generally not transparent to the cellular network and it occurs on the cellular frequencies (Inband) or unlicensed spectrum (Outband) (Kar and Sanyal, 2018).

In a cellular network, all communications go through the BS even when devices are in range for D2D communication. Usually, communication through the BS adapts conventional low data rate mobile services such as text messages and voice calls in which users are rarely close enough for direct communication (Kar and Sanyal, 2018). However, the mobile users of today's cellular networks use high data rate services (gaming app exchange, video sharing, proximity-aware social networking) of which could be done directly (as in D2D) if in range with the other device which it communicates with. This, therefore, saves the cost for cellular communication and increases bandwidth that aids better efficiency in the network. In other words, D2D communications can increase the spectral efficiency of the network (Jameel *et al.*, 2018). Furthermore, D2D technology offers many advantages such as ultra-low latency communication, higher spectral efficiency. It is also considered as one of the promising techniques for 5G wireless

communication networks and can be used in different fields like public safety, network traffic offloading, social services, and applications such as video streaming, gaming, and military applications (Ansari *et al.*, 2018).

1.2 Device to Device Applications

In recent times, the need for D2D communication has been on the increase. This is because of the need to exchange information. As a result, the application of D2D communication includes:

1.2.1 Data transfer

Today, the transfer of data is a norm. Data transfer services such as the transfer of data either in the form of apps, videos files, and audio files, which has often time been the tradition via the cellular network have been the reason for much pressure on the network. However, to reduce the pressure on the network, some of the data exchange could be done directly to another user equipment without the need for the base station if in the coverage area of the radios in the equipment. Hence D2D is applied. (Gandotra *et al.*, 2017).

1.2.2 Internet of Things (IoT)

Today the presence of billions of things on the Internet is also a reason for the poor quality of services. There are scenarios where information between two nodes may not need the cloud and hence may not need a cellular network because of the proximity between the two nodes. However, by combining D2D with IoT, an efficient network with less pressure on the cellular network will be achieved. An example of D2D-based IoT enhancement is vehicle-to-vehicle (V2V) communication on the Internet of Vehicles (IoV). As its moves, a vehicle can warn forthcoming vehicles using D2D of challenges on the road (Gandotra *et al.*, 2017).

1.2.3 Emergency communication

In cases of natural disasters like earthquakes, hurricanes, and some other abnormal situations, the cellular communication network may be limited in terms of signal strength, impeding the transfer of information which may be critical through the traditional network means. The ad-hoc network can be established via D2D between two or more user equipment to save the situation (Gandotra *et al.*, 2017).

1.3 Architectures of D2D Communication

D2D communication is a technology that enables the communication between multiple devices with or without the involvement of network infrastructure (Kar and Sanyal, 2018). The aim of this is towards reducing energy consumption for devices, offloading traffic from the network (Burghal *et al.*, 2017). To achieve this, there are four main types of D2D communication:

1.3.1. Device relaying with base station-controlled link formation:

In this type of communication, a device at the edge of a cell in a poor coverage area can communicate with the BS by relaying its information via other devices. This allows the Network to achieve a higher quality of services (QoS) and aid sustainability of the battery life of the device used (Gupta *et al.*, 2015; Tehrani *et al.*, 2014). Figure 1.1 shows device relaying with base station-controlled link formation.

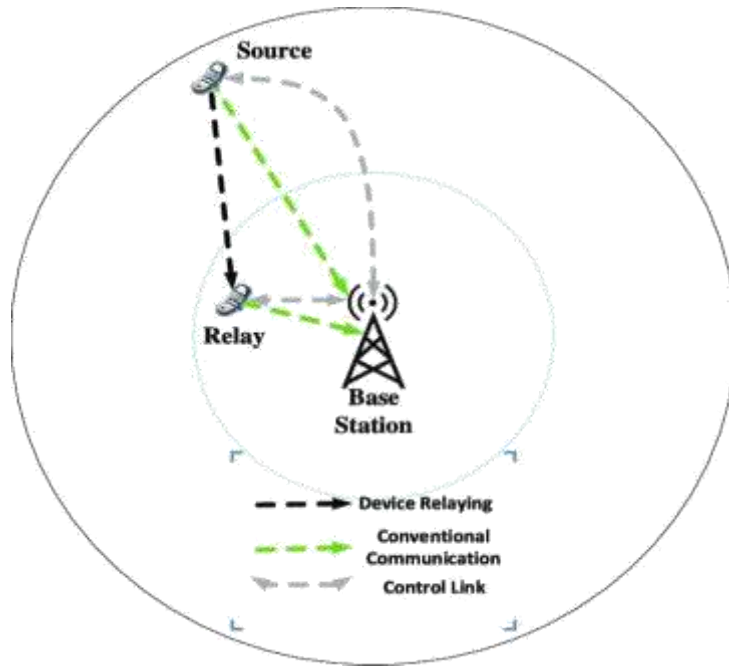

Figure 1.1: Device Relaying with Base Station-Controlled Link Formation (Gupta *et al.*, 2015).

1.3.2 Direct D2D communication with based station-controlled link formation:

In this kind of D2D communication as shown in Figure 1.2, the Source and destination devices are constantly exchanging data with each other without the involvement of a BS, however, it is important to note that the communication is still supported by the BS for link formation (Gupta *et al.*, 2015; Tehrani *et al.*, 2014).

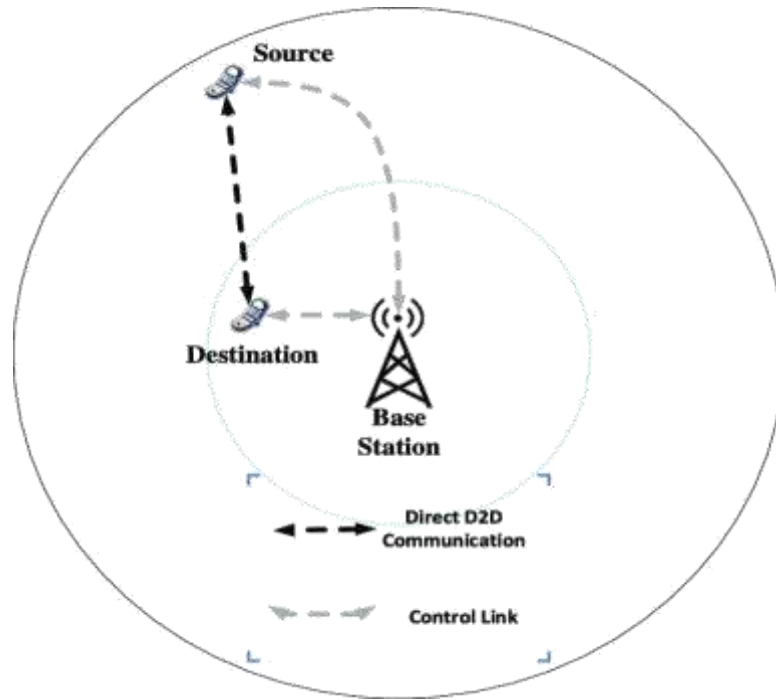

Figure 1.2: Direct D2D Communication with Based Station-Controlled Link Formation

(Gupta *et al.*, 2015).

1.3.3. Device relaying with device-controlled link formation:

For this kind of D2D communication, the BS is not involved in link formation or communication purposes. Thus, the source and destination devices as shown in Figure 1.3 are responsible for synchronizing communication using relays among each other (Gupta *et al.*, 2015). This eliminates the use of base station which ensures that more bandwidth which is scarce is available for other users in the network.

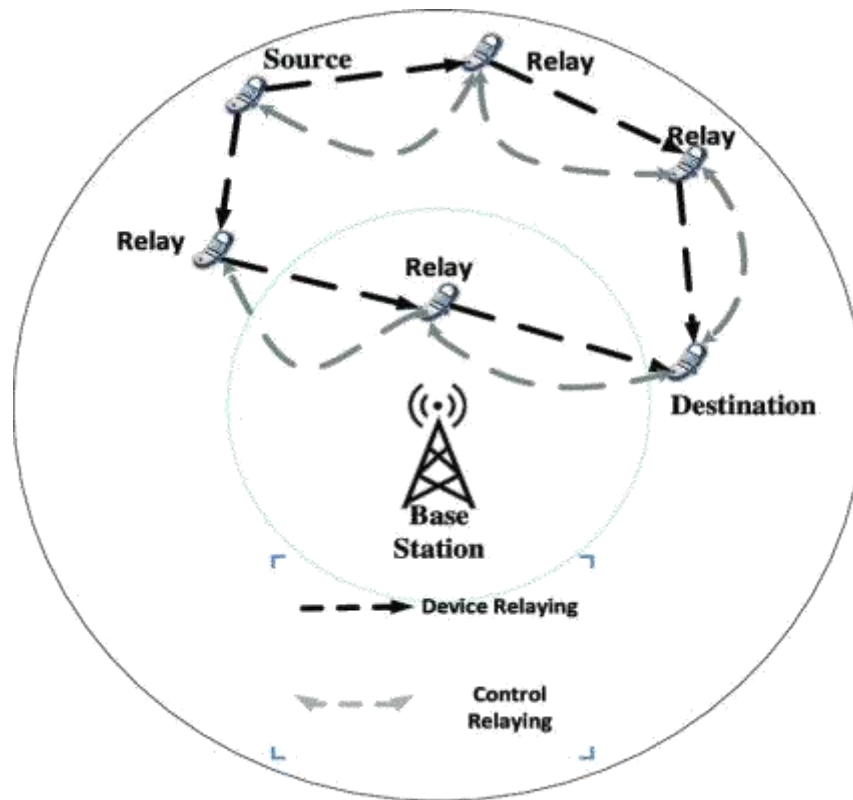

Figure 1.3: Device Relaying with Device-Controlled Link Formation (Gupta *et al.*, 2015)

1.3.4. Direct D2D communication with device-controlled link formation:

D2D communication as shown in Figure 1.4 the source and destination devices directly communicate with each other without any assistance from the BS. Therefore, source and destination devices use their resources to ensure limited interference with other devices (Gupta *et al.*, 2015; Tehrani *et al.*, 2014).

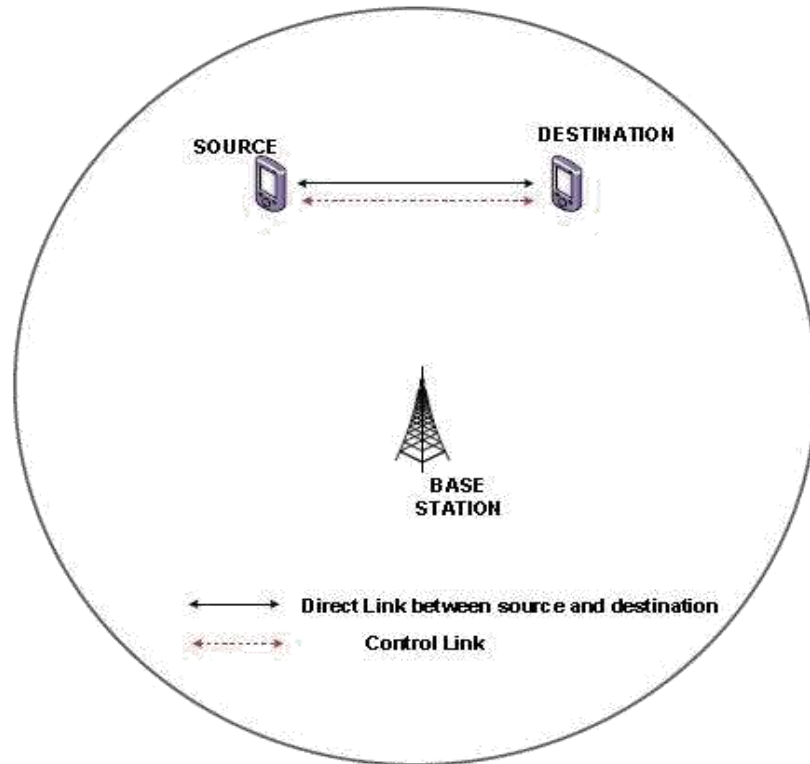

Figure 1.4: Direct D2D Communication with Device-Controlled Link Formation

(Gupta *et al.*, 2015)

However, among all these four methods of D2D communication, the fourth is what is adopted in this research.

Although, the requirements for the next generation of communication systems referred to as 5G, are still debated by the academics and the industry, of which fairly broad consensus has been reached pertaining few key requirements such as a 1-millisecond end to end round trip delay latency, 1000x bandwidth per unit area, 10-100x number of connected devices, up to 10 years battery life for low power/machine-type devices (Xiang *et al.*, 2016). Apart from the inevitable increase in bit rates, energy efficiency of the system, the excessive increase of multimedia applications such as High definition (HD) movies, mobile gaming, multimedia file sharing, video conferencing, the requirements agreed to, has triggered a rapid advancement in cellular communication and its technology. As a

result of that, the pressure on the cellular network is on the increase with the increase in advancements as a result of huge demands.

To aid further development and reduce pressure which increasing efficiency, one of the emerging technologies known as Device to device (D2D) communication, has been proposed by researchers to bridge the gap between communicating devices (Guo *et al.*, 2016). For instance, in isolated regions, the current cellular networks may offer some level of Quality-of-Service (QoS), but they cannot meet the extreme capacity demands in the future if they have to handle situations where users located near one another, such as residential environment, stadiums, shopping malls, and even open-air-festivals have to communicate on the same network. This will result in the crowding of the network with devices reducing the bandwidth and increasing poor QoS due to the pressure on the network.

Furthermore, this results in large traffic volumes having a negative impact on both the network operation, as well as pricing models (Firdose, 2017). To avert this ill, some of these devices within the coverage area of the radio in them could communicate with each other directly thus, assisting in a better network offloading. In other words, the technology involved which is D2D allows devices close to communicating using a direct link rather than having their radio signal traveling through the base station (BS) (Singh and Singh, 2018). This improves cellular coverage, increases resource utilization, and reduces latency (Jameel *et al.*, 2018). The further benefit, however, includes ultra-low latency due to its short signal traversal path. This is achieved via the use of various short-range wireless technologies like WiFi Direct, Bluetooth, and Long Term Evolution (LTE) defined by the Third Generation Partnership Project (3GPP) standardization is often time suggested (Jameel *et al.*, 2018; Kar and Sanyal, 2018).

However, it is important to note that these D2D supporting technologies differ in device discovery mechanisms, data rates, and coverage distance. Bluetooth as observed by (Jameel *et al.*, 2018) supports a maximum data rate of 50Mbps and a coverage range close to 10m. WiFi Direct has a data rate of 250Mbps and a coverage range of 200m, while, LTE Direct has data rates of 13.5Mbps and a coverage range of 500m. All these mentioned technologies are characterized by short-range and consume energy. However, this may not apply to scenarios with larger coverage areas. According to (Rizzi *et al.*, 2017) LoRa (Long Range technology) is characterized with the capability to cover 10km surpassing the already mentioned supporting D2D technologies.

Furthermore, it is observed that the D2D already in existence usually employ all these supporting technologies manually. In other words, the operator will have to select the technology to be used for communication. To improve device discovery in D2D with scenarios of large coverage area, without expending much energy and having the ability to automatically selects the technology to be used for data transfer based on the area of coverage, this research presents Automatic radio selection for data transfer in D2D.

1.4 Statement of the Research Problem

The manual selection of radio channels for data transfer in D2D has been a norm for quick and complimentary communication. Such selection process can possibly lead to delay and increase in power consumption. This work introduces an autonomous selection process to reduce delay and energy demand in D2D communications.

1.5 Aim and Objectives of the Study

This research aims to automate radio selection for data transfer in D2D. To achieve this, the following objectives are followed

- i. Design pair device with two radio channels built-in each device

- ii. Incorporate automatic radio selection codes into each device
- iii. Evaluate the performance of the system via field test
- iv. Compare the results of manual selection with the automatic radio selection

1.6 Justification of the Research

Several kinds of research have been done on D2D devices. The aim is to reduce pressure on the cellular network which is characterized by scarce bandwidth. Among these methods used Piyare & Tazil, (2011) designed a Bluetooth-based home automated system on a standalone Arduino Bluetooth board that was connected with the home appliances. Choi *et al.* (2018), used the Bluetooth contact patterns of users and the cell tower information to predict the availability of WiFi connectivity for users within the WiFi range to connect. Hayati *et al.* (2017), designed a system where LoRa was used for the tracking and monitoring of patients with mental disorders. However, to the best of our knowledge, no research has considered automatic selection of the radios to aid D2D communication.

1.7 Scope of the Study

The study will look at establishing an automatic radio selection for data transfer in D2D with the distance of 10km as the criteria

1.8 Thesis Outline

This thesis is structured in five (5) chapters as follows: Chapter One is the introduction, which introduces Device to Device (D2D) communication. Chapter Two is the Literature review that presents various existing approaches reached by other researchers to achieve device discovery. Chapter Three presents the Research Methodology and how the aim and objectives of this research were carried out. Chapter Four is the presentation of the results. Chapter Five is Conclusion and Recommendations.

CHAPTER TWO

2.0. LITERATURE REVIEW

2.1 D2D Discovery and Controls using Bluetooth

Over the years D2D has been researched to achieve cheaper means of data transfer. Bluetooth also known as Bluetooth Low-Energy (BLE), because of its short-range characteristics, was one of the earliest supporting technologies used in D2D. The BLE which operates on the spectrum range of 2.4-2.4835 GHz of the ISM band is designed to provide communication at low power (Park *et al.*, 2017). With this understanding, Oosterlinck *et al.* (2017) tracked devices in a cooperative building using Bluetooth indoor positioning service (BIPS). The concept which involves the collection of Bluetooth devices that can communicate with each other by sharing a common channel called piconet was used. In his presentation, every mobile BIPS user is represented on a handheld device equipped with Bluetooth for interacting with a static device.

Piyare and Tazil, (2011) focused on a Bluetooth-based automated home using a cell phone. The model was designed on a standalone Arduino Bluetooth board and the home appliances are connected to the input/output ports of this board via relays. The Bluetooth-based home automated system is designed to be low cost but yet scalable, allowing a variety of devices to be controlled with minimum changes to its core. Lodhi *et al.* (2016), presented a voice-controlled wheelchair for the physically challenged person, where the voice command controls the movements of the wheelchair. The voice command is given through a cellular device having Bluetooth and the command is transferred and converted to a string by the Bluetooth voice control for Arduino and is transferred to the Bluetooth Module SR-04 connected to the Arduino board for the control of the wheelchair.

Gandotra *et al.* (2016) developed an android application used as a remote to control the motion of an RC car. The mobile device harboring the android application acts as the

car's remote control. The communication between the android application and the controller is enabled by Bluetooth. Another study presented by Choi *et al.* (2018), focused on Blue-Fi, a system that predicts the availability of Wi-Fi connectivity by using a combination of Bluetooth contact patterns and cell tower information. This allows the device to intelligently switch the Wi-Fi interface on only when there is Wi-Fi connectivity available, avoiding the long periods in idle state and significantly reducing the number of scans for discovery.

2.2. LTE D2D Discovery

The last decade has experienced growth in both the amount of mobile broadband traffic and the user demand for the faster data access (Burghal *et al.*, 2017). Considering that the current 4G technology cannot satisfy the present communication demand and the forthcoming user demand, the Third Generation Partnership Project (3GPP) developed an enhanced Long-Term Evolution LTE radio interface called LTE-Advanced (Kar and Sanyal, 2018).

Sun *et al.* (2015) modelled two basic scenarios to achieving device discovery using LTE which the first is the broadcasting mode where the device wishing to be discovered broadcasts a message containing its identification information, while devices that want to discover scan and decode the broadcast message and can determine if the device is in its proximity. The second scenario is the Request-Response mode where the device trying to discover another device sends a message containing its identity information to the target device, after the target device is done decoding the message it allows the device trying to be found to discover the target device by configuration, sends a response message to the originating device revealing the proximity. The results of this modelling give efficiency in energy consumption in the first scenario and better interference management. While

the request-response mode consumes large energy on the devices if there is no prior information from the discovering device.

Benedetto *et al.* (2017) used LTE as a proximity base to support the Mobile Crowd Sensing (MCS) feature, Figure 2.1 shows how they presented the MCS method. The MCS feature is installed into smart devices to achieve device discovery. The MCS platform assigns a task to participants who are active and generate sensing data. Each task to be completed may include multiple data gathering actions in a given period within an area of interest; these actions are performed automatically by the MCS app without human interaction (except for initially accepting the task) or may require some active response by the participant. As observed, to provide a detailed user's feedback about an event. The MCS platforms include an MCS server that assigns tasks and gathers participants' information from the MCS client app installed on their devices. The result showed efficient location sharing and energy consumption. Limitations were the cost of application development and user acceptance.

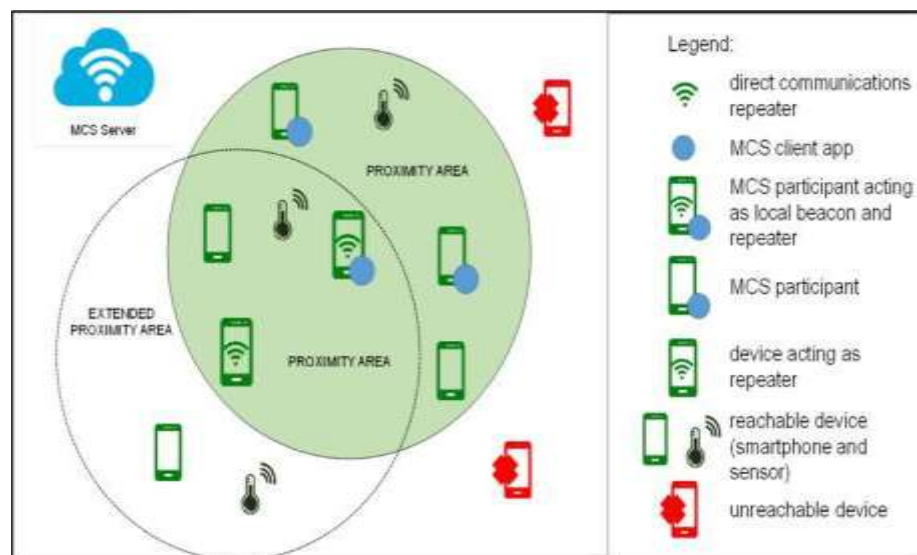

Figure 2.1: Mobile Crowd Sensing (MCS) Feature into Smart Devices to achieve Device Discovery (Benedetto *et al.*, 2017)

Ben-mosbah *et al.* (2019), used Timing Advance (TA) to assist the mobile network to determine the distance between two or more devices and they also proposed a direct approach where each device broadcasts its discovery signal to determine the other device's location. The result they achieved apart from discovery was efficiency in energy consumption and spectrum utilization. Singh and Singh (2018) used the parameters of LTE-Advance by introducing the Full Duplex Amplify and Forward (FDAF) Relay Nodes (RNs) to assist cellular network and D2D communication. The result of this experiment was the increase in the coverage probability for both cellular and D2D communication with the relay nodes.

In world news, natural disasters occur frequently. Jedidi *et al.* (2017) take advantage of 3GPP and D2D communication to help save lives. D2D can be an alternative communication in a natural disaster situation with a total or partial absence of network infrastructure. Proposed that receiver probes all physical resource blocs in a given spectrum band-based LTE networks to be able to detect victims. The spreading technique is used when an SOS is transmitted and correlation is analyzed in the receiver side in order to decide whether a victim is using a Resource Bloc to ask for help or not. As well, to multiply the number of receivers in different location to exploit the user's diversity in order to enhance the detection accuracy based on hard information combining. Hence, receivers will cooperate to derive a reliable decision about an SOS transmission.

Nguyen *et al.* (2018) introduced a technique called ROOMMATE which Used the Proximity Based Service (ProSe) to provide the list of available devices and their colocation information and uses the information to help in peering decision process. This model was proposed for a small number of discovery signals and reduce the collision probability of discovery signals.

2.3 WiFi D2D Discovery

The IEEE 802.11 standard for Wireless Local Area Networks (WLANs), commonly known as Wi-Fi (Ding *et al.*, 2018), has become a choice for short-range communication, due to the cost-effective deployment. Its network is implemented on a large scale and is available for WiFi devices such as smartphones, consumer electronics, and industry sensors. In recent times, WiFi direct was released, it is built upon the IEEE 802.11 infrastructure mode and offers direct, secure, and rapid D2D communication. The WiFi direct has become an interesting and suitable technology for communication in applications (Khan *et al.*, 2017).

Ding *et al.* (2018) designed a smart home based on the principles of WiFi technology as shown in Figure 2.2 embedded the QCA9531 wireless communication module to an STM32F107VCT processor and provided a 5V power for the Wi-Fi wireless module to control the home system through an android platform. The APP user interface contains the welcome interface, login interface, the main interface. Where a user needs to register an account in the APP, set a password and log into the main interface to ensure the privacy of the user. The main interface contains the settings interface and the home control interface.

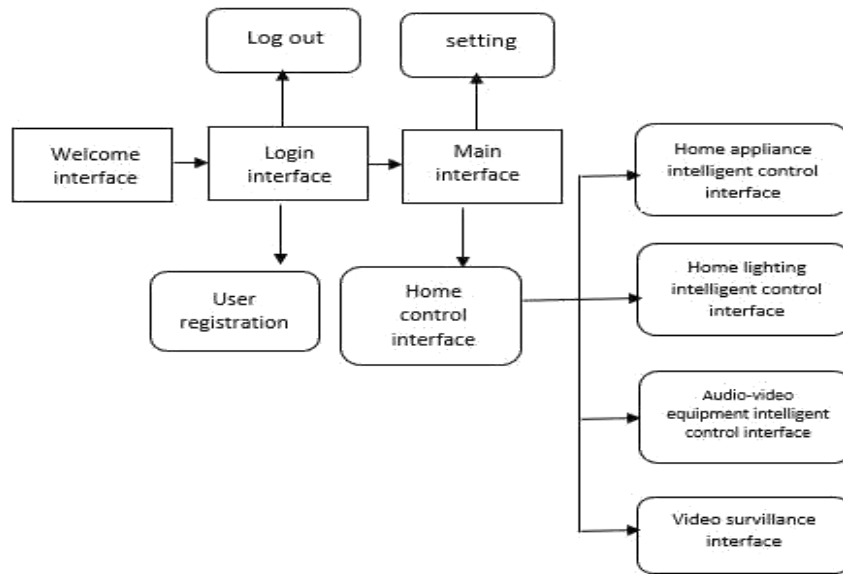

Figure 2.2: Design of the User Interface for a Smart Home Based on the Principles of WiFi Technology (Ding *et al.*, 2018)

Wen *et al.* (2011) introduced a handheld indoor directory system built on WiFi-based positioning techniques. The system consists of three modules, namely the mobile phone module, kiosks module, and database module. The mobile phone module is the main frontend module installed on users' mobile devices, whereas the Kiosks and website are to provide supports and maintenances to the main module. Users can download maps and applications from the Kiosks or websites. On the other hand, an administrator uses the website to manage the database. The system provides a new way of providing an indoor floor directory, which offers capabilities to retrieve customizable information, to navigate interactively, to enable location-awareness computing, and most importantly the portability of the directory system.

Shen *et al.* (2016), identified several attacks that challenge WiFi Direct-based D2D communications. Since pairwise key establishment lies in the area of securing D2D communications, introduced a Short Authentication String (SAS) based key agreement

protocol and analyze its security performance. The SAS-based key agreement protocol is integrated into the existing WiFi Direct protocol, and implemented in android smartphones.

The WiFi Aware was used by some researchers, which enables low power discovery over WiFi and can light up many proximities based on used cases. Ishino *et al.*, (2017) modeled an architecture based on the cellular networks to accommodate non-cellular Internet of Things (IoT) devices by device working as relay devices for IoT devices and internet uses as shown in Figure 2.3. WiFi Aware was also used as a supporting technology for proximity services to discover relay devices. The result of this model reduces the energy consumption of devices in IoT.

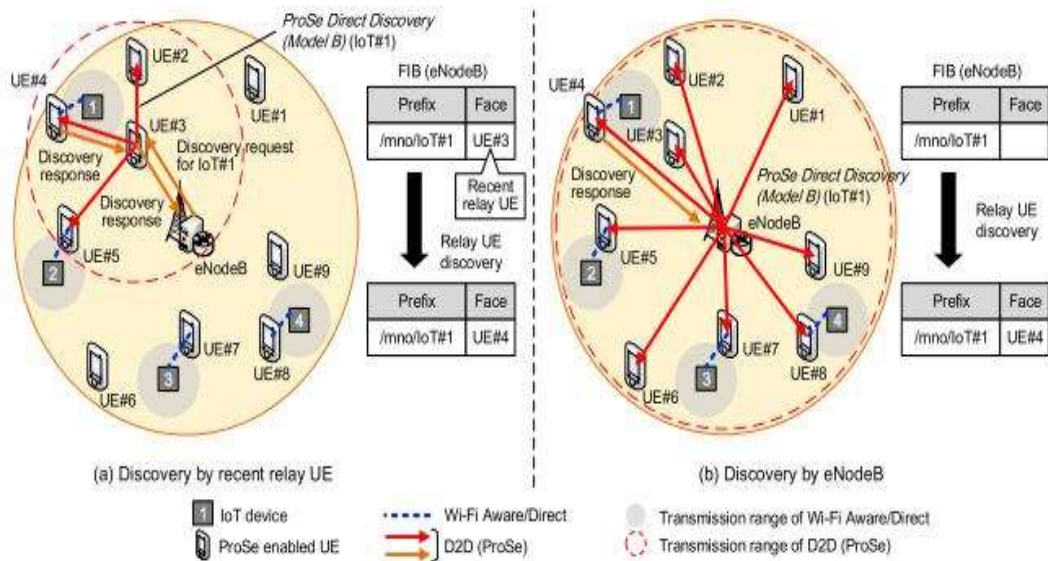

Figure 2.3: Two Types of ProSe-Assisted Relay D2D Discovery Mechanism. (Ishino *et al.*, 2017)

2.4 LoRa D2D Discovery

In recent years, Low-Power Wide Area (LPWA) technologies are becoming popular due to the rapid growth in wireless communication. Supporting technology such as Long Range (LoRa) Technology which is a low-power, low bitrate, and wireless technology

engaged as an infrastructure solution for Internet of Things (Zhou *et al.*, 2019). LoRa aims to assess the “worst-case” coverage of the technology, by having an estimated number of gateways to cover a city (Mekki *et al.*, 2018).

Hayati *et al.* (2017) presented as shown in Figure 2.4 a system used on the Internet of Things (IoT). A LoRa based technological platform for the tracking and monitoring of patients with mental disorders. The system consists of the LoRa end device (client-side) which is a wearable device attached to the patient, and LoRa gateways, installed in the hospital and other public locations. The LoRa gateways are connected to local server and cloud servers by exploiting both mobile cellular and WiFi networks as the communications media.

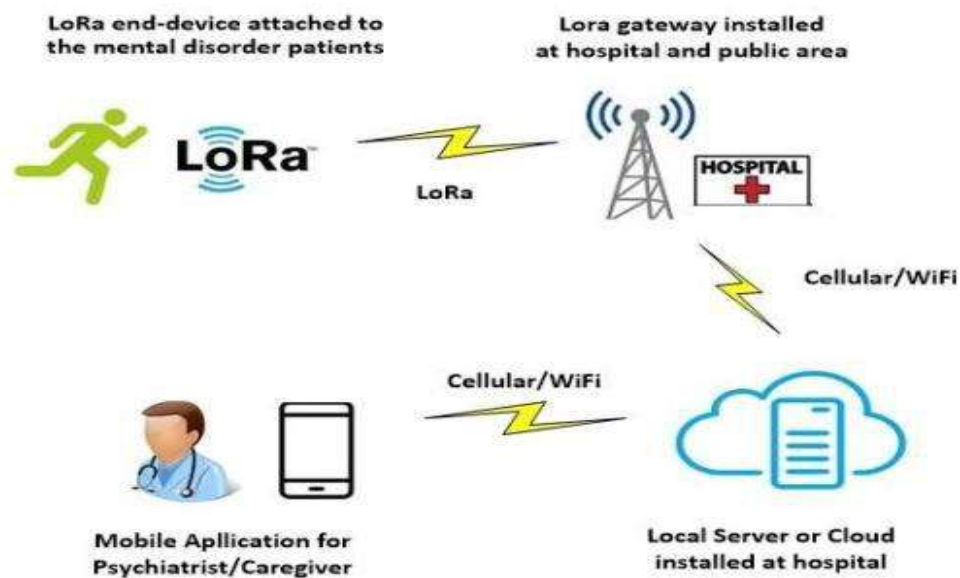

Figure 2.4: Tracking and Monitoring System for Mental Disorder Patients based on LoRa Technology Hayati *et al.*, (2017)

Fargas *et al.* (2017) presented a LoRaWAN tracking system, which is capable of exploiting transmitted packages to calculate the current position without using GPS. This is done using LoRa where the geolocation is calculated applying a multilaterate algorithm on the gateways timestamps from received packages. The whole system consisted of an

end-node, four gateways, a server, and a java application to store the obtained data in a MySQL database.

Zhao *et al.* (2018), presented as shown in figure 2.5 an object tracking system using LoRa, which was deployed on bicycles for location tracking and managing system. The structure is composed of an end device, gateway, server, database, and user web and application. For the end device, Wasmote is used attached with an internal acceleration sensor, GPS sensor, and SX1272 of LoRa module. For the gateway, Meshlium is used, which is based on Linux OS, has SX1272 of LoRa Module, and offers Bluemix MQTT API. For the server and database, the data provided by IBM Bluemix and the database by Mongo DB are used. IBM Bluemix that serves the role of server, the Broker receives data and transfer to Bluemix server. The data is saved to Mongo DB, in which data is provided in Cloud form in Bluemix. The Wasmote installed on a bicycle saves data in IBM Bluemix by using gateway and offers services to the mobile APP and website to locate the bicycles.

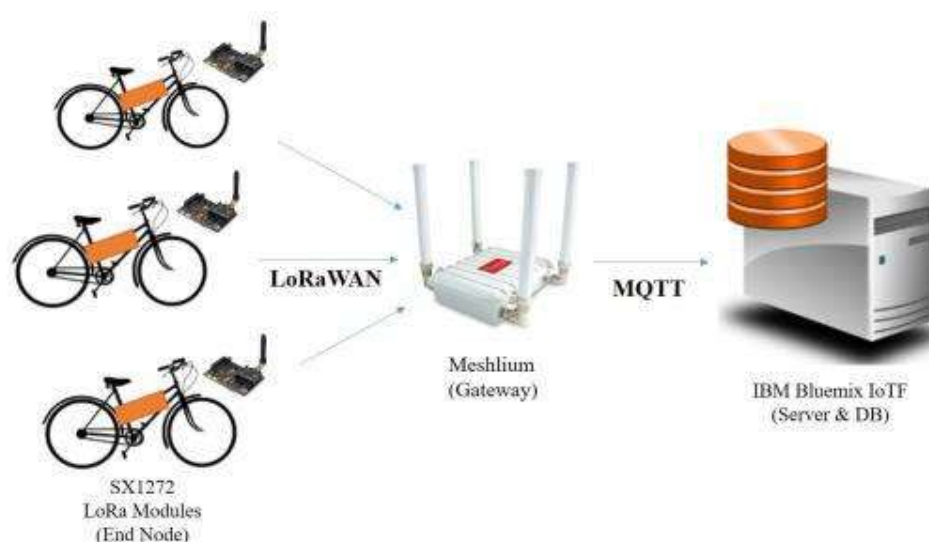

Figure 2.5: Experiment Environment on an Object Tracking System (Zhao *et al.*, 2018)

Another study presented by Rizzi *et al.* (2017) used LoRa for industrial applications compared to the traditional industrial wireless system. With light modifications to the upper layer of the LoRaWAN communication stack. The result of their study shows the

feasibility of the approach, which is compatible with the requirements for soft real-time applications in the process industry. Table 2.1 presents the comparison between Bluetooth, Long Term Evolution (LTE), Wireless Fidelity (Wi-Fi), and Long-Range technology (LoRa) according to the (Jameel *et al.*, 2018; Kar and Sanyal, 2018; Rizzi *et al.*, 2017).

Table 2.1: Comparison between Various Techniques

	Owner	Range	Data rate	Power Requirement
Bluetooth	Open – IEEE certified	10m	100kbps	Low
LTE	GSMA – cellular carriers	1.7km urban 20km rural	13.5Mbps	Band dependent
WiFi	Open – IEEE certified	30m indoor 200m outdoor	250Mbps	Medium
LoRa	LoRa alliance	3km urban 10km rural	0.3 - 37.5kbps	Low-power

All these contributions done by various researchers made contributions on device discovery on D2D with those supporting technologies, which were manually operated. In other words, the operator will have to select the technology to be used for communication. To improve device discovery in D2D with scenarios of large coverage area, without expending much energy by designing a subunit that automatically selects the technology to be used for data transfer based on the area of coverage, this research presents an Automatic radio selection for data transfer in D2D device.

CHAPTER THREE

3.0 RESEARCH METHODOLOGY

This section presents the method and materials used to achieve the aim which is to automatically select radio based on a distance between two devices. This was achieved via the use of hardware and software.

3.1 Materials

3.1.1 Software

C++ was used to programme the Arduino IDE. The code developed was burned on the controller. Fritzing was used to simulate the design.

3.1.2 Hardware

The components used to implement the design includes:

- i. Controller
- ii. Lora radio
- iii. Bluetooth module
- iv. Multiplexer/ Demultiplexer
- v. Power Supply
- vi. Display
- vii. Sensor

To achieve efficiency, the system has to be planned and deployed. Device A gets its location, then sends a request to send (RTS) and its location which is received by device B, which measures its location and computes the distance between both devices. If the distance between device A and device B is less than or equal to 10m, device B will send an Acknowledgement (ACK) telling Device A to send a message via Bluetooth then, establish the connection before the message is sent. if the distance is more, device B sends

ACK telling device A to send a message via LoRa then establish the connection before the message is sent from device A to device B.

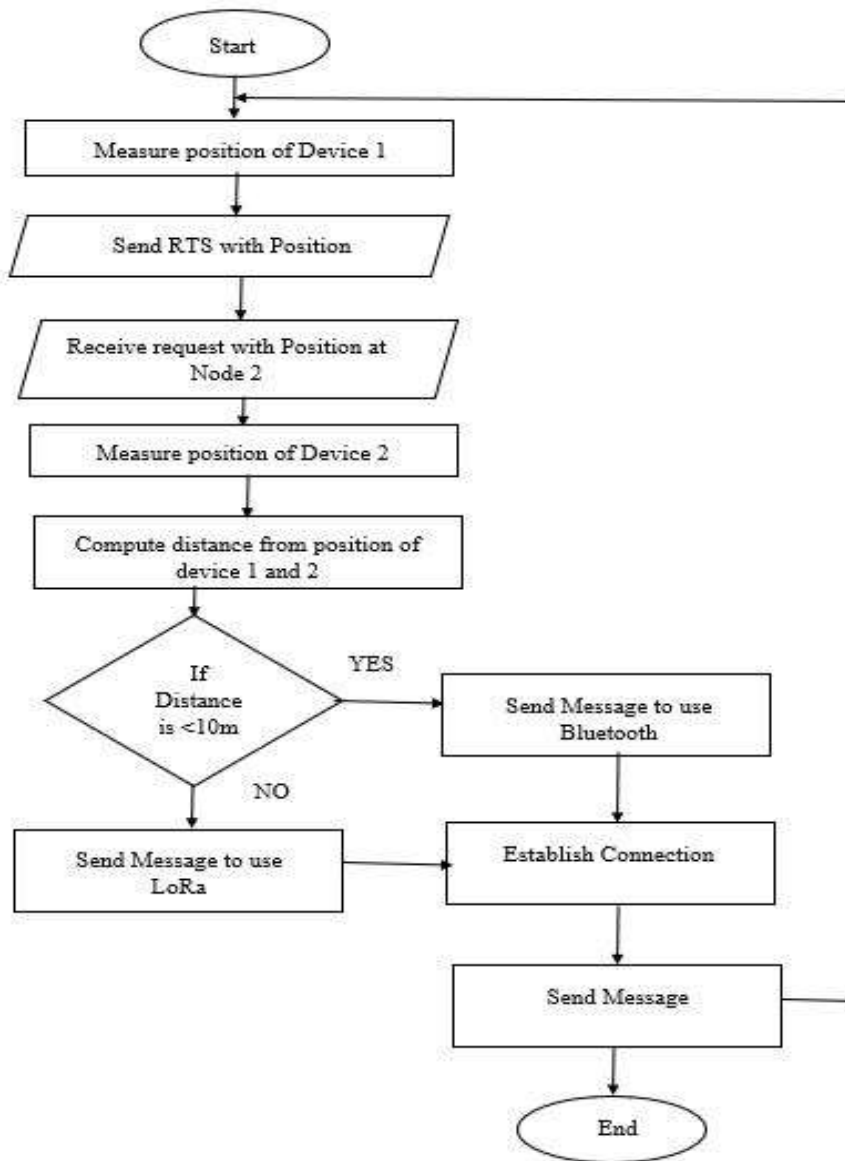

Figure 3.1 Flowchart of the System

3.3 Network Scenarios

Scenario One

Device A trying to establish a connection with Device B, first sends its GPS coordinates and an RTS to Device B, Device B collects this information received from Device A calculates the distance between them. If the distance between them is $<10\text{m}$ it's sent

back an ACK with the Bluetooth, then Device A connects to Device B with the Bluetooth which both devices can now communicate.

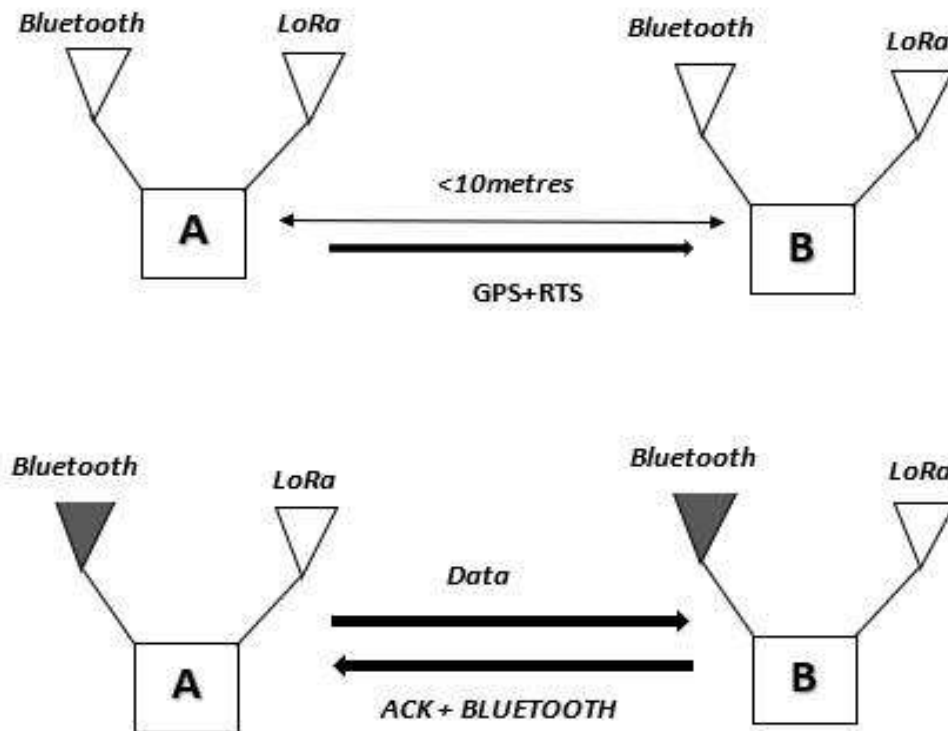

Figure 3.2: Network Scenario for Distance <10metres

Scenario Two

Device A trying to establish a connection with Device B, first sends its GPS coordinates and an RTS to Device B, Device B collects this information received from Device A calculates the distance between them. If the distance between them is >10m it's sends back an ACK with LoRa, then Device A connects to Device B with LoRa which both devices can now communicate.

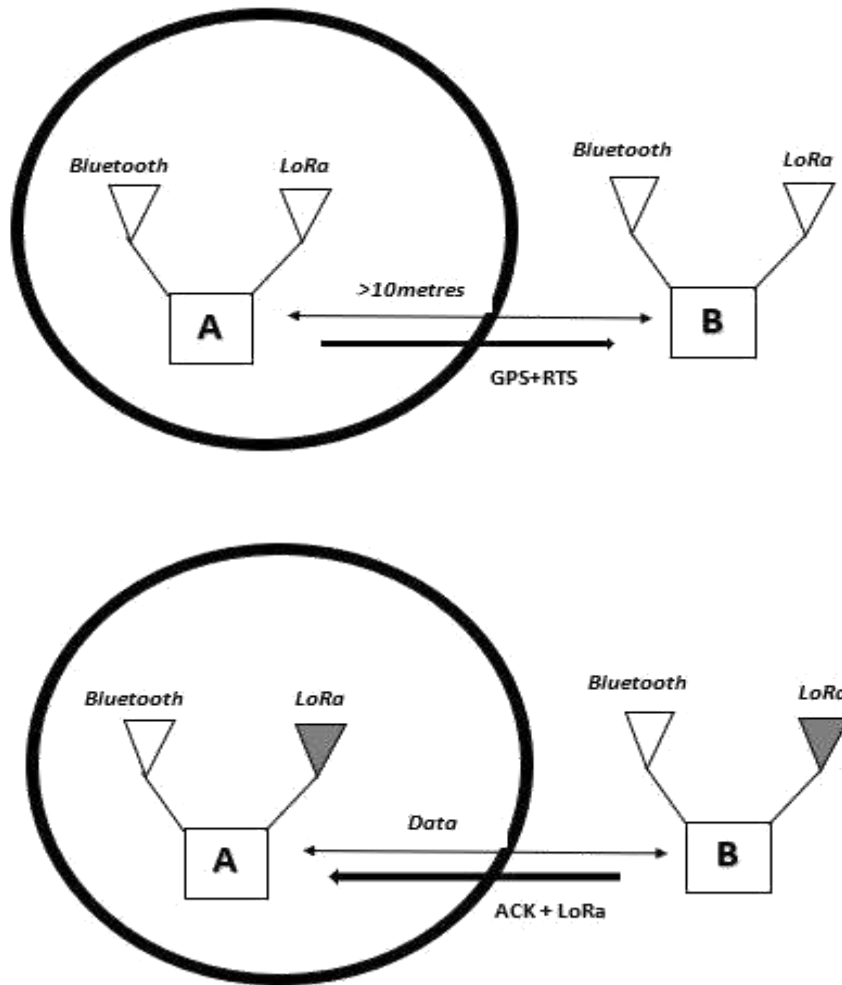

Figure 3.3: Network Scenario for Distance >10metres

3.4 Hardware Design

The hardware of the two devices is designed with the architecture shown in Figure 3.4. The battery-powered devices consist of a controller which is interfaced with a LoRa radio, Bluetooth module, and a GPS via a multiplexer. The multiplexer is used to expand the universal asynchronous receiver transmitter (UART) communication protocol. Furthermore, the controller is interfaced with an alphanumeric display and a sensor.

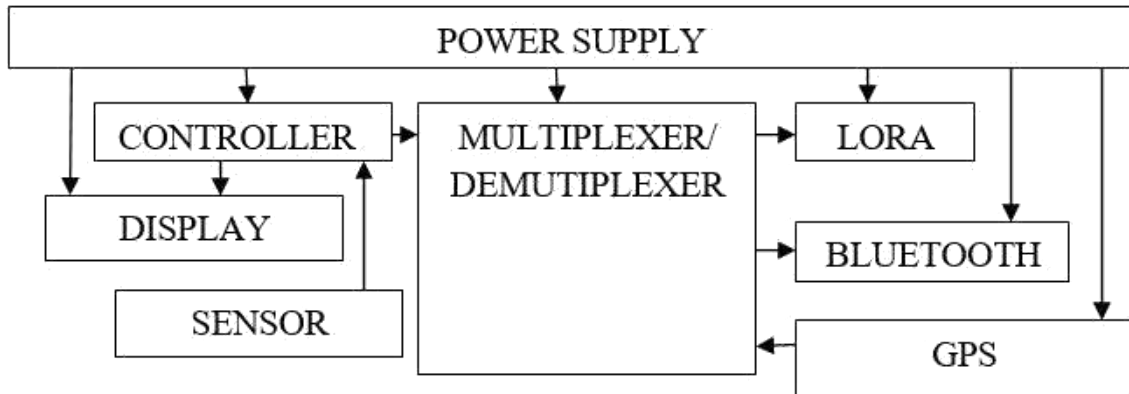

Figure 3.4: Architecture of the System

3.4.1 Power supply

The power supply used in this research consists of two lithium batteries and a voltage regulator. The voltage regulators used as shown in Figure 3.5 depend on the voltage requirement of the different devices in the system. According to the datasheet, the controller used needs 3V to 12V to be powered on. Also, the LoRa needs 3.3V which is achieved via the use of LM317 while Bluetooth and the GPS are powered by a 5V regulator. The resistor R1 and RV1 are used to determine the voltage the LM317 outputs. To determine the values of R1 and RV1, equation (1) is considered

$$V_{out} = 1.25 \left[1 + \frac{RV}{R_1} \right] \quad (3.1)$$

From the datasheet, the voltage at the input must be more than the output voltage by a head voltage. The head voltage as prescribed is 2.5V. Also, the minimum current the regulator can deliver is 10mA. Therefore, to maintain constant reference voltage R1 will be given as

$$R_1 = \frac{1.25}{I} = 120 \text{ohms}$$

According to the datasheet, the value of R1 can range from 120Ω to 1kΩ. Let the value of R1 in this design be 240Ω. To calculate for RV1

$$V_{out} = 1.25 \left[1 + \frac{RV_1}{R_1} \right]$$

3.3V + 2.5V = 1.25 V

$$RV_1 = 840 \text{ ohms}$$

To use a variable resistor, one can use 1kΩ which is a little higher than the calculated value.

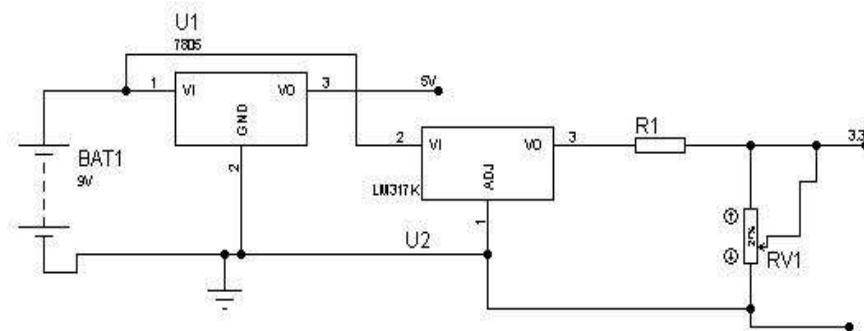

Figure 3.5: Circuit Diagram of the Power Supply

3.4.2 Controller

The controller used in this research is an Arduino Nano. The controller as shown in Figure 3.6 was chosen because of its robust nature as the controller has an onboard programmer. Furthermore, it is made up of digital input-output pins. The controller also has ADC and one UART port which is used to interface the GPS, Bluetooth, and the LoRa module.

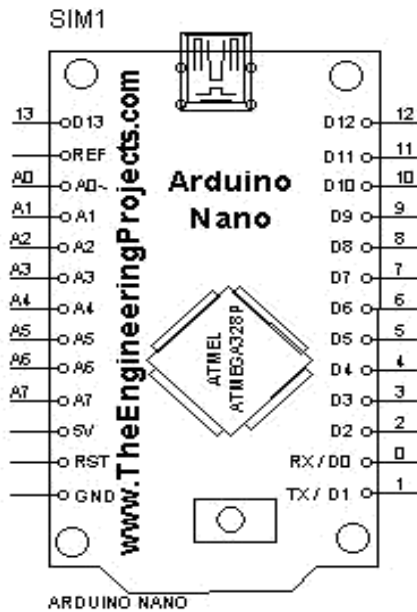

Figure 3.6: Arduino Nano Pinout Diagram

3.4.3 Display

The Screen used in the research is an alphanumeric display. The Liquid crystal display (LCD) 1602 is interfaced with the controller as shown in Figure 3.7 such that the controller communicates with the display via four bits. The number of characters which the LCDs in total is 32 characters. Sixteen characters are displayed on the upper line and the remaining sixteen on the lower line making 32 characters in total, hence, the name 1602. The display is interfaced with the controller serial port.

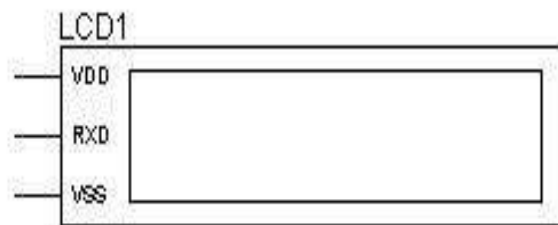

Figure 3.7: LCD 1602

3.4.4 Sensor

The sensor used in this research is a momentary switch (SW). The switch is connected in series with a resistor (R2) as shown in Figure 3.8. This is done to achieve two logics namely logic High which is 5V and logic LOW which is 0V. The LOW logic is achieved when the switch is closed. The reason for the switch in the design is to send a message to the next device.

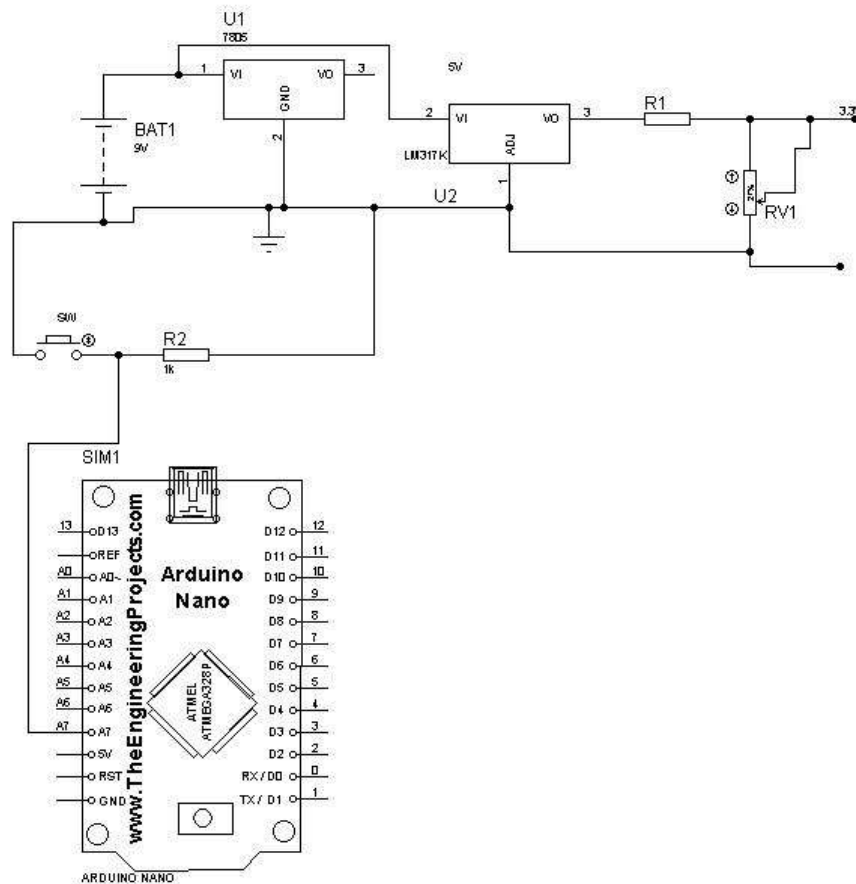

Figure 3.8: Circuit Diagram of a Switch Interfaced with the Controller

3.4.5 Multiplexer

The Multiplexer used is CD4052. The integrated circuit is used to multiplex and demultiplex signals can be used to select different serial signals channeled to the single serial port of the controller. This is used to interface two devices which are GPS and

Bluetooth module which both have UART port. Figure 3.9 shows the circuit diagram of the multiplexer interfaced with the system.

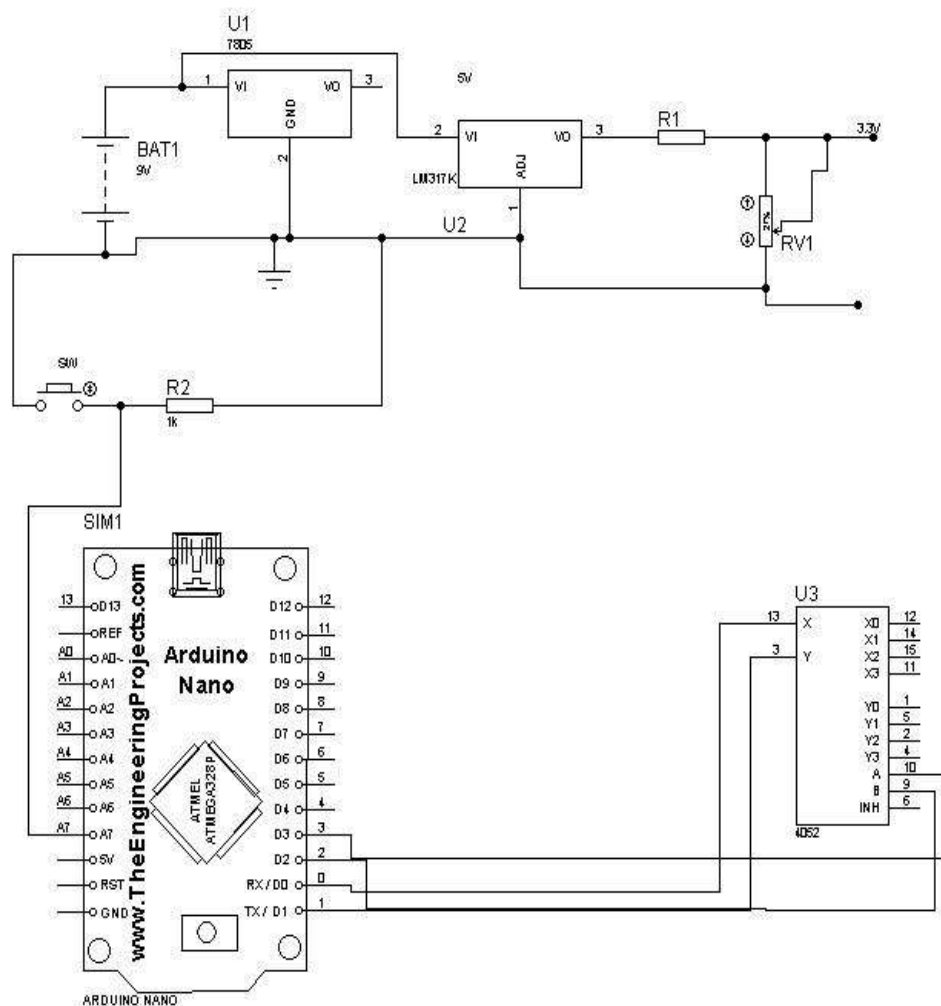

Figure 3.9: Circuit Diagram of the Multiplexer Interfaced with the System

3.4.6 LoRa radio

The primary means of communication in this device is the LoRa (long-range) module. The module gives the system to communicate in a range of 10km while maintaining low power consumption. The specific LoRa module used is SX1278 which operates at a frequency of 433MHz. Figure 3.10 shows the interface of the radio with the system which communicates with the controller via the SPI interface.

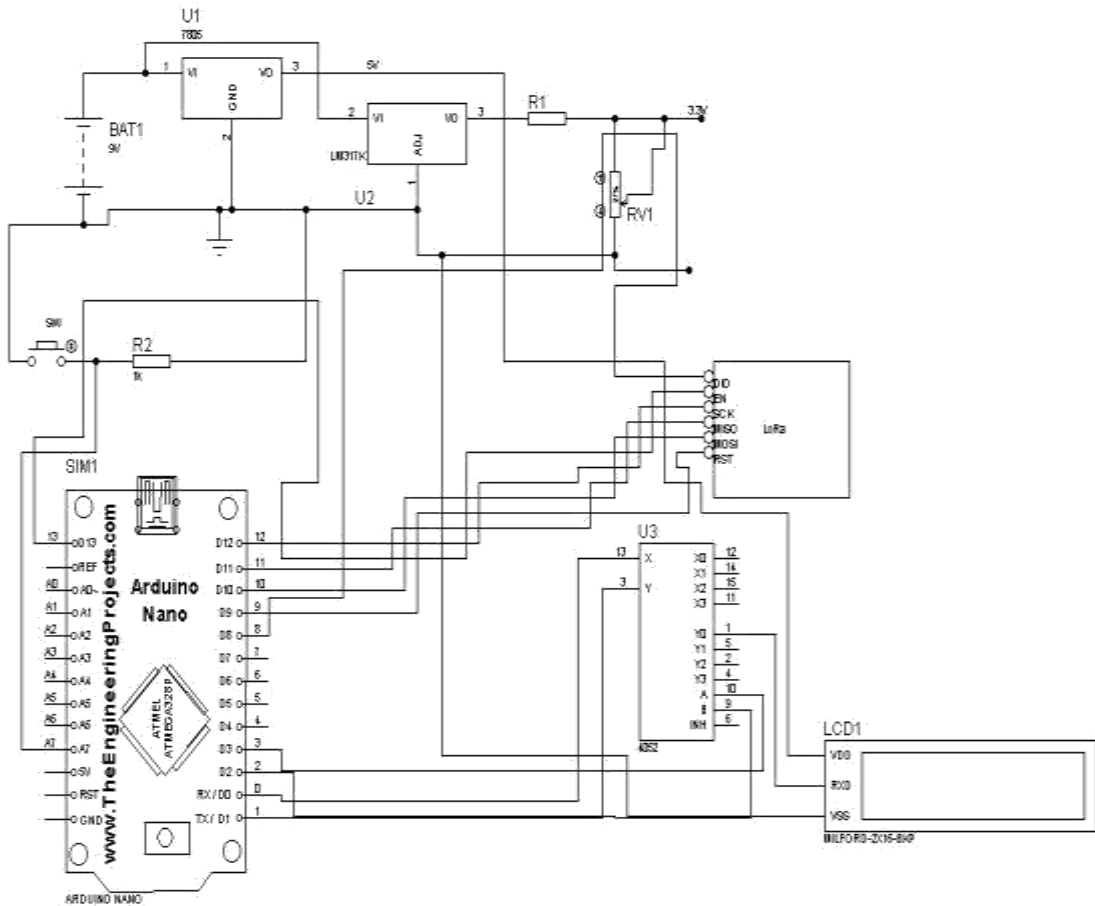

Figure 3.10: Circuit Diagram of the System Interfaced with LoRa.

3.4.7 Bluetooth

The Bluetooth device used is HC05. This is used in the system to aid short-distance communication. The Bluetooth module is interfaced with the controller via the UART port is powered with 5V. Figure 3.11 illustrates the interconnection of the device with the system

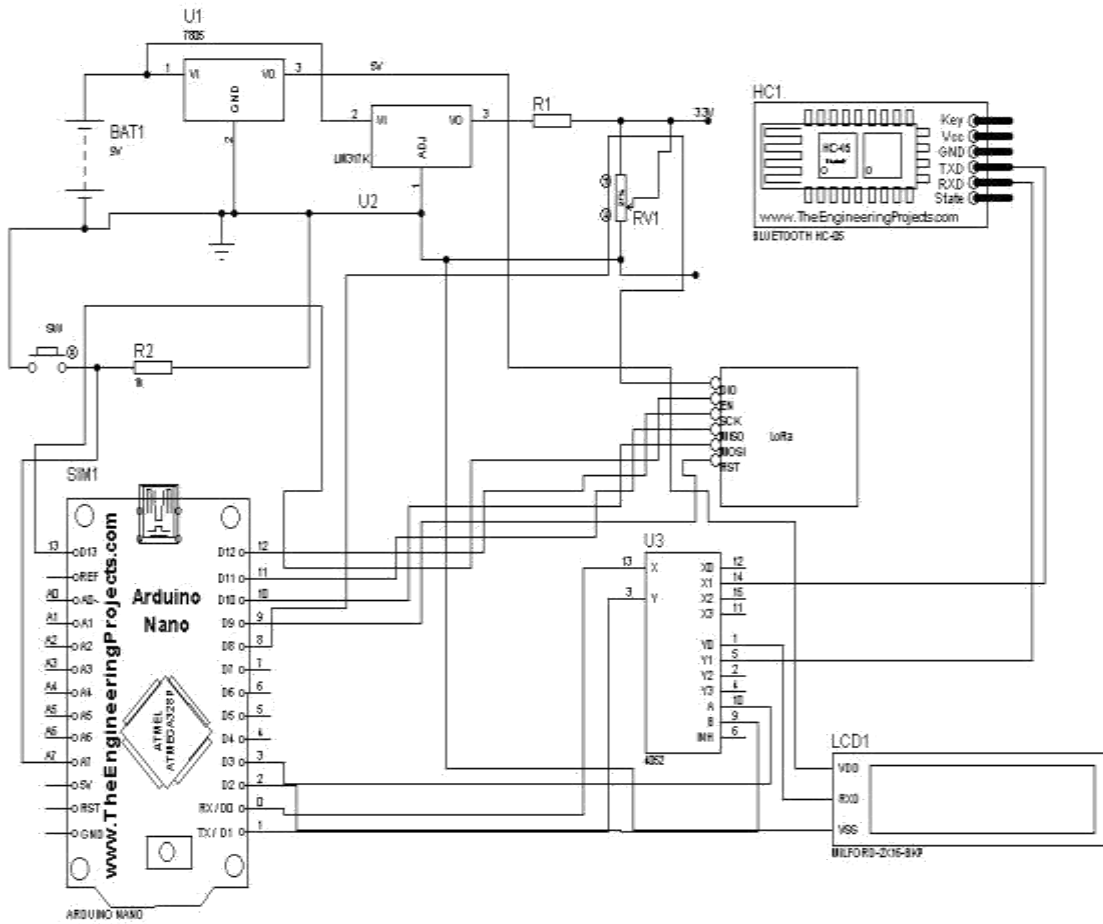

Figure 3.11: Circuit Diagram of the System Interfaced with the Bluetooth Radio.

3.4.8 Distance measurement Via GPS module

The GPS module used in the system was used to determine the distance between two devices. This is achieved via the use of the longitude and the latitude of the location where the device is. The transmitting device will take its location and send it to the receiving device with a request to send using the LoRa communication. In the request to send is the location. The receiving device will use this to determine its distance from the transmitter. Then advise the system to transmit using LoRa or any other radio depending on the distance.

Here is the formula for calculating the distance between the two devices using the GPS module on the Arduino device:

The mean circumference of the earth is

$$2 \times 6,371,000\text{m} \times \pi = 40,030,170\text{m} \quad (3.2)$$

$$\Delta d (\text{lat}) = 40,030,170 \times \Delta\Theta (\text{lat}) / 360 \quad (3.3)$$

(Assuming $\Delta\Theta$ is small)

$$\Delta d(\text{long}) = 40,030,170 \times \Delta\Theta (\text{long}) \times \cos\Theta_m / 360 \quad (3.4)$$

(Θ_m : mean latitude between two positions)

Now, the distance is

$$D = \sqrt{[\Delta d (\text{lat})^2 + \Delta d (\text{long})^2]} \quad (3.5)$$

Distance Measuring (and More) Device Using Arduino and GPS (2021, July 13)

<https://www.instructables.com/Distance-measuring-and-more-device-using-Arduino-a/>

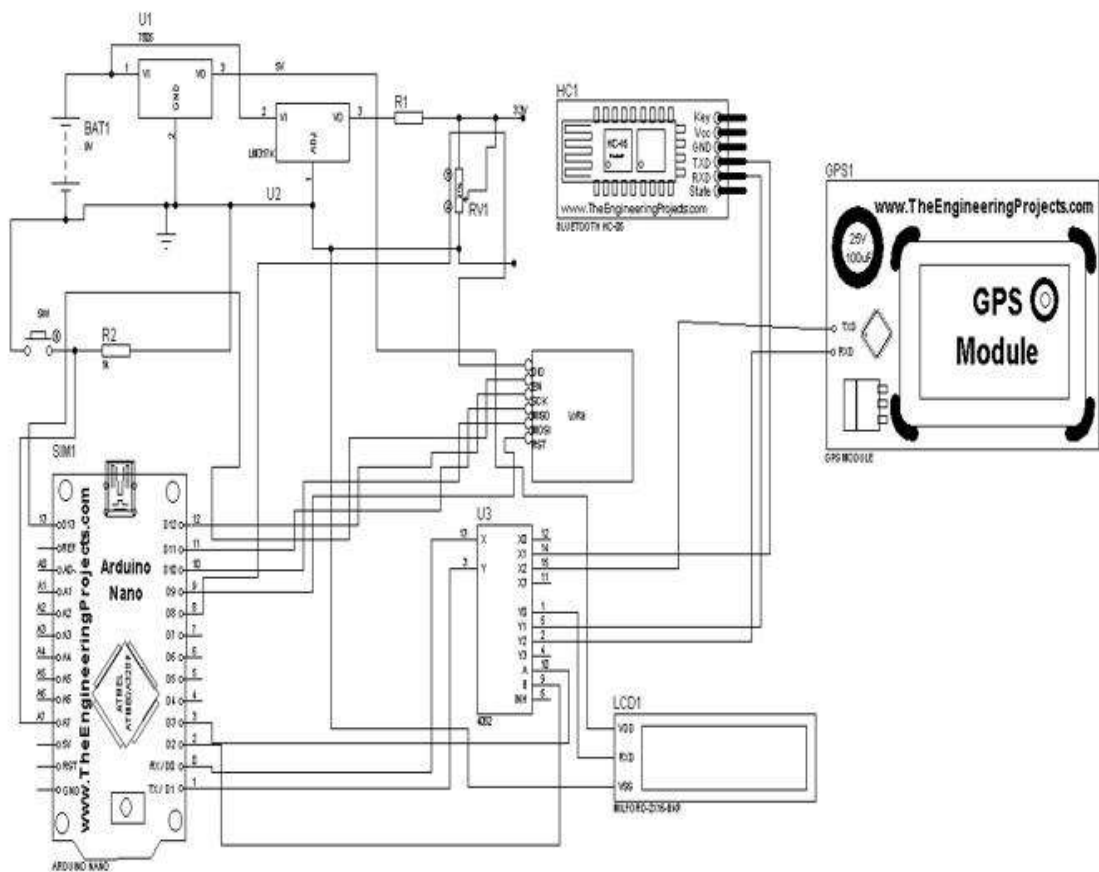

Figure 3.12: Complete Circuit Diagram of the System.

The components were soldered on a Vero board as shown in Figure 3.13. As a result of the nature of the components used, the board dimension achieved is (Height: 10cm, Length: 12cm, Breadth: 12cm). Furthermore, the devices were packaged using the model board.

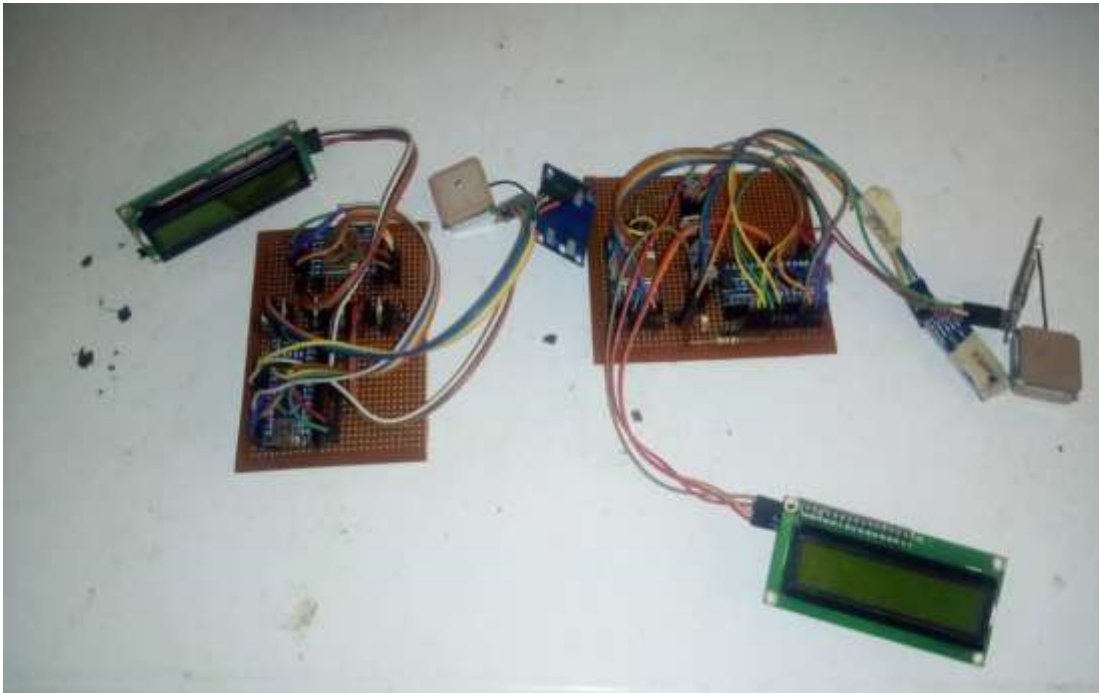

Figure 3.13: Assembled Hardware Component of the Automatic Radio Selection System

3.4.9 Communication pattern between the two devices

The communication within the system is shown in figure 3.14. The transmitter sends an (RTS) containing its GPS location (longitude and latitude) through a LoRa radio. The receiver acknowledges it and then processes the information given. It computes the distance between it and the transmitter. Afterward, it sends a message containing the suggested radio and a clear to send (CTS). The transmitter receiving this then turns on the suggested channel and then sends the data intended.

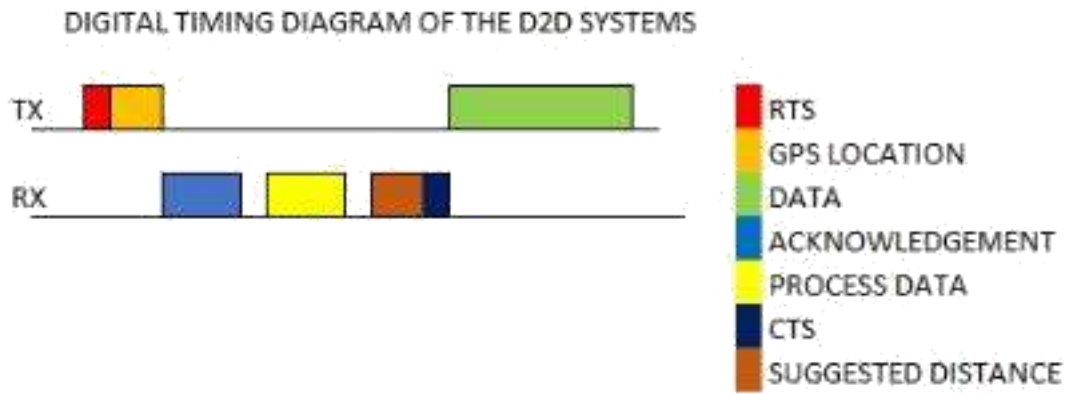

Figure 3.14 Timing Diagram Illustrating the Communication within the System.

CHAPTER FOUR

4.0 RESULTS AND DISCUSSIONS

4.1 Result for Delay

To ensure that the deployed device can achieve a reduction in the delay to establish connectivity, there was a comparison between the deployed D2D and an existing device. The device used to compare with the deployed D2D is an Android smartphone with a specification of 1GB (one gigabit) RAM to estimate the time taken to for a device to connect with another from point-blank (when the user manually selects the radio on the device) to when Bluetooth connectivity is achieved.

Table 4.1: Time of Operation on the Deployed Automated Device.

S/N	Trial	Time of operation
1	1	6.45sec
2	2	4.09sec
3	3	4.52sec
4	4	5.47sec
5	5	4.48sec

Table 4.2: Time of Operation on a Manually Controlled Smartphone.

S/N	Trial	Time of operation
1	1	17.36sec
2	2	7.55sec
3	3	8.45sec
4	4	10.05sec
5	5	13.37sec

In Table 4.1, the time of operation of deployed D2D system was presented. The estimated time is taken for our D2D to establish the connection from the moment it requests to send till the connection has been established. This active D2D system will initiate a connection via the use of LoRa, then determines the longitude and latitude of the receiving device whose initial reception state is also on LoRa. The receiving device receives the packet, it then takes its longitude and latitude and determines the distance between its device and Device A. After that, it sends an acknowledgment to connect, and then based on the distance, the radio to be used for communication. Device A getting the information will turn off the LoRa (if the distance between the two devices is less than 10m, and if the distance between the devices is more than 10m the Bluetooth will stay off) and use the suggested radio. Note that receiving device has already switched to the radio it advised. There was a comparison between the android smartphone and the deployed D2D after the trials for the time taken to establish the connection as shown in Table 4.2. The average time was calculated with the equation.

$$\text{Average time} = \frac{\sum h}{h} \quad (4.1)$$

The average time is taken for the android smartphone with 1GB of RAM

$$\frac{17.36 + 7.55 + 8.45 + 10.05 + 13.37}{5} = 11.36\text{sec}$$

The average time is taken for the deployed D2D

$$\frac{6.45 + 4.09 + 4.52 + 5.47 + 4.40}{5} = 5\text{sec}$$

The average time taken after trials for the android smartphone device with 1GB RAM is 11.36sec, while it is 5sec on the deployed device. These results show that the time taken for connectivity is less in the automated D2D compared to the manually controlled android smartphone.

4.2 Result for Energy Consumption

Figure 4.1 shows the graphical illustration of the result for energy consumption of the device. The deployed D2D's battery was tested between time intervals of data transfer with a Multimeter to know the amount of energy consumed by the device in a time frame of twenty-four hours. It was observed that the amount of battery power consumed after twenty-four hours was 10%

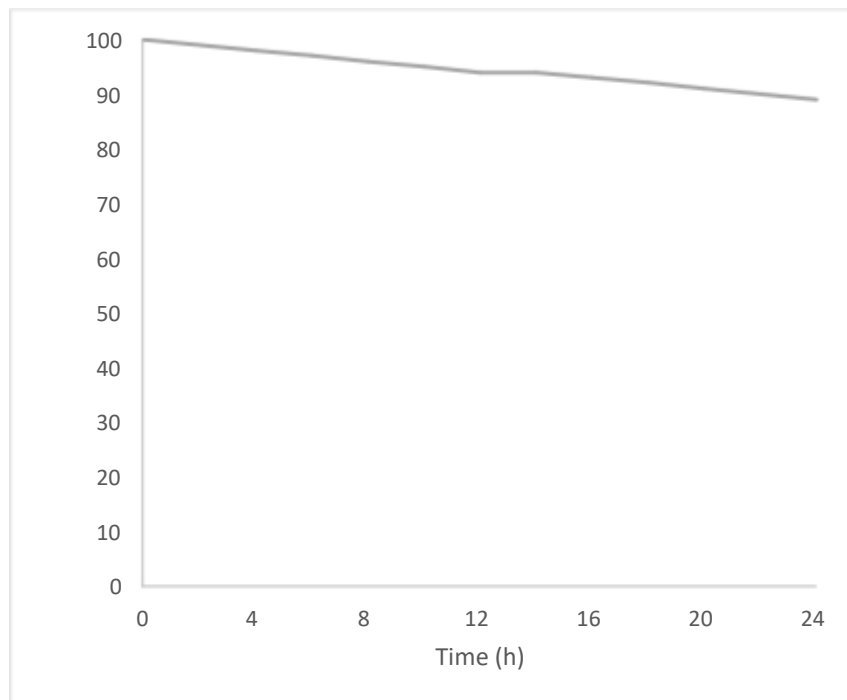

Figure 4.1: Energy Consumption of the Deployed D2D

In Table 4.3, the battery capacity was measured using the Multimeter within time intervals of data transfer and tabulated.

Table 4.3: Energy Consumption of the Deployed D2D against Time

Time (h)	Percentage (%)
0	100
4	99
6	98
8	97
10	96
12	95
14	94
16	94
18	93
20	92
24	90

4.3 Result for Radio Selection

In Table 4.4, the distance measured and the actual distance were presented to compute the error in the distance which may be as a result of clock drift of the satellites, multipath delay, and signal propagation delay in the atmosphere. For better understanding, the test was conducted on both bright and cloudy weather conditions to determine the accuracy of the device in both conditions.

Table 4.4: Error in Distance and Error in Selection on a Bright Day.

S/N	Distance measured (m)	Actual measurement (m)	Error in distance (m)	Radio selection	Error in selection
1	1.3	1.28	0.02	BT	Nil
2	3.6	3.54	0.06	BT	Nil
3	5.4	5.5	-0.1	BT	Nil
4	7.7	7.65	0.05	BT	Nil
5	9.9	9.87	0.03	BT	Nil
6	10.13	10	0.13	BT	Error
7	11	10.95	0.05	LoRa	Nil
8	12.4	12.2	0.2	LoRa	Nil

Table 4.5 Error in Distance and Error in selection on a cloudy day

S/N	Distance measured (m)	Actual measurement (m)	Error in distance (m)	Radio selection	Error in selection
1	1.4	1.28	0.12	BT	Nil
2	4	3.54	0.46	BT	Nil
3	5.8	5.5	0.3	BT	Nil
4	7.9	7.65	0.25	BT	Nil
5	10.3	9.9	0.4	BT	Error
6	10.35	10	0.35	BT	Error
7	11.05	10.95	0.1	LoRa	Nil
8	12.5	12	0.5	LoRa	Nil

At the end of the test, it was observed that on the sixth trial in table 4.10, there was an error in radio selection. Also, on the fifth and sixth trials in table 4.2, there was an error in radio selection. This infers that more error is observed on cloudy days than on bright days as a result of clock drift of the satellites, multipath delay, and signal propagation delay in the atmosphere. Furthermore, the accuracy was calculated and it was observed based on the equation.

$$= \frac{\text{Number of correct selections}}{\text{Total number of trials}} \times 100 \quad (4.2)$$

The calculation for accuracy for test on a bright day
 $7/8 \times 100 = 87.5\%$

The calculation for accuracy for test on a cloudy day
 $6/8 \times 100 = 75\%$

The accuracy of radio selection was 87.5% on a bright day while that on a cloudy day is observed to be 75%.

Figure 4.2 presents the graphical representation of the trials in Table 4.1; the graph represents the accuracy as one (1) and the error in selection as zero (0). The error occurred in the sixth trial. This error is a result of the device selecting Bluetooth instead of LoRa since the receiving device is few centimetres away from the maximum distance of Bluetooth after taking the actual measurement between the two communicating devices.

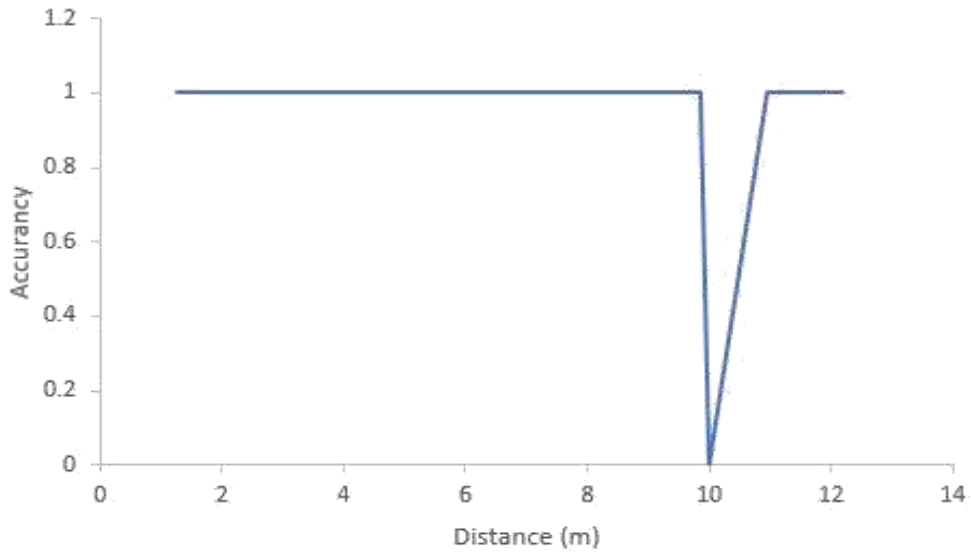

Figure 4.2: Graphical Representation of Trials on a Bright Day.

The graphical representation of the trails in table 4.2 is represented in Figure 4.3, the graph represents the accuracy as one (1) and the error in selection as zero (0). The error occurred in the fifth and sixth trials. This error is a result of the device selecting Bluetooth instead of LoRa since the receiving device is few centimetres away from the maximum distance of Bluetooth after taking the actual measurement between the two communicating devices.

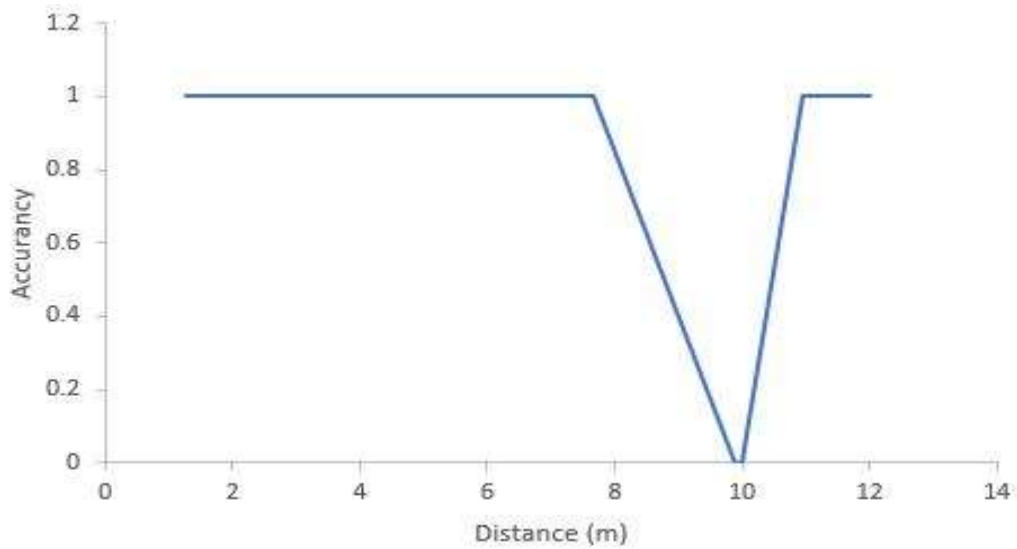

Figure 4.3: Graphical Representation of Trials on a Cloudy Day.

4.4 Comparison of Result

Liu and Striegel, (2011) in their work presented an evaluation of power consumption for Bluetooth and WiFi in a smartphone. Nurgaliyev *et al.*, (2020), presented an evaluation of power consumption for LoRa based wireless sensors network. It is important to note the battery in these devices was not of the same voltage capacity, there was a scaling to estimate the consumption of energy on the devices throughout twenty-four hours. A comparison of this work and Liu and Striegel, (2011), Nurgaliyev *et al.*, (2020) is presented in Figure 4.5, which shows that the deployed D2D with LoRa and Bluetooth has the best capability of energy saving.

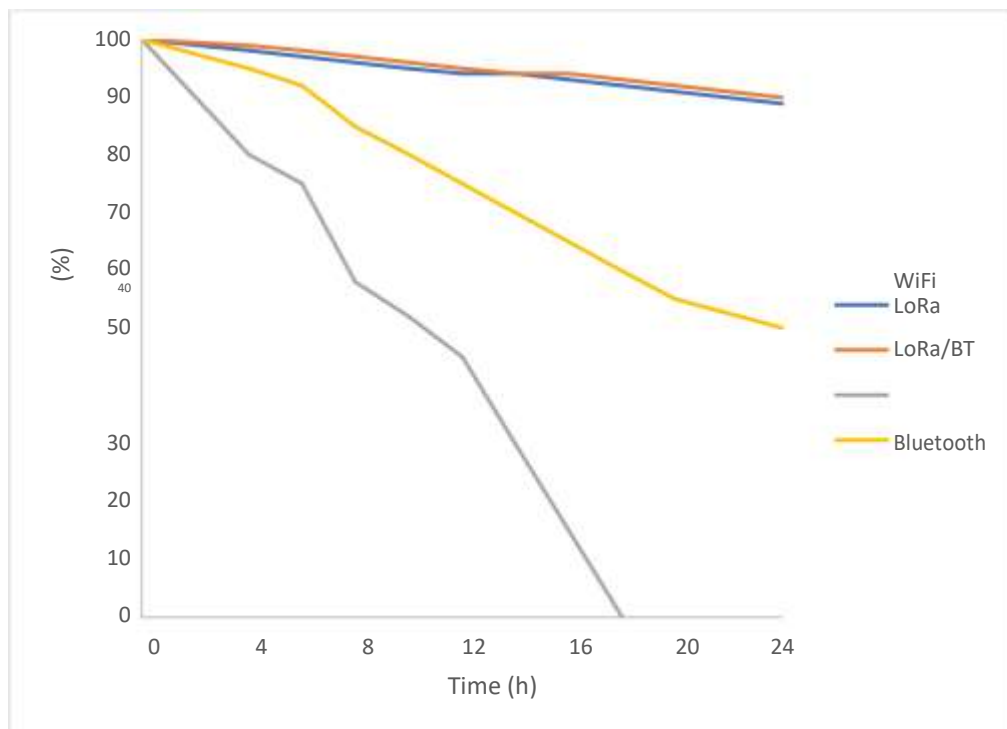

Figure 4.4: Energy Consumption of Bluetooth, WiFi, LoRa and LoRa/Bluetooth

CHAPTER FIVE

CONCLUSION AND RECOMMENDATIONS

5.1 Conclusion

D2D communication is expected to provide benefits over conventional cellular networks. D2D communication shows great promise as one of the most promising and favorable paradigms for future networks. Though various researchers have approached achieving D2D with different techniques. This research was designed and implemented upon a scenario of direct D2D communication between two devices, to automatically establish communication between both devices in respect to the distance and which radio is best for such communication. If the device is within the Bluetooth range (0-10m) it connects, or as far as the LoRa (10km) range as well, and with the lesser time taken compared to a manually controlled smart device.

5.2 Recommendations

In the future, this work can be improved with the use of different techniques like adapting this concept into our smartphones to achieve a direct D2D. For better performance, a better controller should be used other than Arduino. The controller should be able to handle seven decimal places. Furthermore, the signal strength could be used to measure the distance instead of GPS.

5.3 Contribution to Knowledge

From the literature, a lot of techniques have been proposed to achieve D2D communication either by, single radio or combined techniques. However, the automatic selection of this radio in a device for communication was not put into consideration by those various researchers. Hence, this research was focused on the design and implementation of an automatic radio selection device for data transfer in D2D in respect of the distance between the transmitting and receiving device.

REFERENCES

- Ansari, R. I., Member, G. S., Chrysostomou, C., Hassan, S. A., Member, S., Guizani, M., Mumtaz, S., Member, S., Rodriguez, J., Member, S., Rodrigues, J. J. P. C., & Member, S. (2018). 5G D2D Networks : Techniques , Challenges . IEEE Systems Journal, 12(4), 3970–3984.
- Ben-mosbah, A., Hammami, S. E., & Mounpla, H. (2019). Enhancing Device-to-Device Direct Discovery Based on Predicted User Density Patterns. Computer Networks. <https://doi.org/10.1016/j.comnet.2019.01.015>
- Benedetto, J. De, Bellavista, P., & Foschini, L. (2017). Proximity discovery and data dissemination for mobile crowd sensing using LTE direct. Computer Networks, 0, 1–12. <https://doi.org/10.1016/j.comnet.2017.08.002>
- Burghal, D., Tehrani, A. S., & Molisch, A. F. (2017, October). Base station assisted neighbor discovery in device to device systems. In 2017 IEEE 28th Annual International Symposium on Personal, Indoor, and Mobile Radio Communications (pp. 1-7). IEEE.
- Choi, J., Lee, G., Shin, Y., Koo, J., Jang, M., & Choi, S. (2018). BLEND: BLE beacon-aided fast WiFi handoff for smartphones. 2018 15th Annual IEEE International Conference on Sensing, Communication, and Networking, SECON 2018, 1–9. <https://doi.org/10.1109/SAHCN.2018.8397124>
- Das, C. B. (2015). A study on device to device communication in wireless mobile network. International Journal of Modern Communication Technologies and Research, 3(3), 265733.
- Ding, J., Li, T. R., & Chen, X. L. (2018, July). The application of Wifi technology in smart home. In Journal of Physics: Conference Series (Vol. 1061, No. 1, p. 012010). <https://doi.org/doi:10.1088/1742-6596/1061/1/012010>
- Fargas, B. C., & Petersen, M. N. (2017, June). GPS-free geolocation using LoRa in low-power WANs. In 2017 global internet of things summit (Giots) (pp. 1-6). IEEE.. <https://doi.org/10.1109/GIOTS.2017.8016251>
- Firdose, S., & Sofia, R. C. (2017). Challenges on the Validation of D2D Communications: Availability of Open-source Tools. COPELABS/ULHT, Tech. Rep.. <https://doi.org/10.13140/RG.2.2.29942.80967>
- Gandotra, P., Jha, R. K., & Jain, S. (2017). A survey on device-to-device (D2D) communication: Architecture and security issues. Journal of Network and Computer Applications, 78, 9-29.
- Gandotra, S., Sharma, B., Mahajan, S., Motup, T., Choudhary, T., & Thakur, P. (2016). Bluetooth controlled RC car using arduino. Int. J. Interdiscip. Res, 2, 144-147.
- Guo, J., Durrani, S., Zhou, X., & Yanikomeroglu, H. (2016). Device-to-device communication underlying a finite cellular network region. IEEE Transactions on

Wireless Communications, 16(1), 332-347.

Gupta, A., & Jha, R. K. (2015). A survey of 5G network: Architecture and emerging technologies. *IEEE access*, 3, 1206-1232.

<https://doi.org/10.1109/ACCESS.2015.2461602>

Hayati, N., & Suryanegara, M. (2017, October). The IoT LoRa system design for tracking and monitoring patient with mental disorder. In *2017 IEEE International Conference on Communication, Networks and Satellite (Comnetsat)* (pp. 135-139). IEEE.

Instructables. (2017, October 19). Distance Measuring (and More) Device Using Arduino and GPS. <https://www.instructables.com/Distance-measuring-and-more-device-using-Arduino-a/>

Ishino, M., Koizumi, Y., & Hasegawa, T. (2017). Relay mobile device discovery with proximity services for user-provided IoT networks. *IEICE Transactions on Communications*, 2016EBP3429.

Jameel, F., Hamid, Z., Jabeen, F., Zeadally, S., & Javed, M. A. (2018). A survey of device-to-device communications: Research issues and challenges. *IEEE Communications Surveys and Tutorials*, 20(3), 2133–2168.

<https://doi.org/10.1109/COMST.2018.2828120>

Jedidi, L., Chekir, M., Louati, F., Bouraoui, R., & Besbes, H. (2017). Cooperative D2D Discovery Approach For Public Safety Based On Spreading Technique. 190–195.

Kar, U. N., & Sanyal, D. K. (2018). An overview of device-to-device communication in cellular networks. *ICT Express*, 4(4), 203–208.

<https://doi.org/10.1016/j.icte.2017.08.002>

Khan, M. A., Cherif, W., & Filali, F. (2017). Wi-Fi Direct Research - Current Status and Future Perspectives. *Journal of Network and Computer Applications*.

<https://doi.org/10.1016/j.jnca.2017.06.004>

Liu, S., & Striegel, A. (2011). Accurate extraction of face-to-face proximity using smartphones and bluetooth. *Proceedings - International Conference on Computer Communications and Networks, ICCCN*, February.

<https://doi.org/10.1109/ICCCN.2011.6006081>

Lodhi, D. K., Vats, P., Varun, A., Solanki, P., Gupta, R., Pandey, M. K., & Butola, R. (2016). Smart Electronic Wheelchair Using Arduino and Bluetooth Module. 5(5), 433–438.

Mekki, K., Bajic, E., Chaxel, F., Meyer, F., Mekki, K., Bajic, E., Chaxel, F., & Meyer, F. (2018). A Comparative Study of LPWAN Technologies for Large-scale IoT Deployment. *ICT Express*. <https://doi.org/10.1016/j.icte.2017.12.005>

Nguyen, N. T., Choi, K. W., Song, L., & Han, Z. (2018). ROOMMATEs: An unsupervised indoor peer discovery approach for LTE D2D communications. *IEEE*

- Transactions on Vehicular Technology, 67(6), 5069-5083.
<https://doi.org/10.1109/TVT.2018.2832223>
- Nurgaliyev, M., Saymbetov, A., Yashchishyn, Y., Kuttybay, N., & Tukymbekov, D. (2020). Prediction of energy consumption for LoRa based wireless sensors network. *Wireless Networks*, 26(5), 3507-3520. <https://doi.org/10.1007/s11276-020-02276-5>
- Oosterlinck, D., Benoit, D. F., Baecke, P., & Van de Weghe, N. (2017). Bluetooth tracking of humans in an indoor environment: An application to shopping mall visits. *Applied geography*, 78, 55-65.
- Park, H., Lee, S., Moon, E., Ahmed, S. H., & Kim, D. (2017, September). Performance analysis of bicycle-to-pedestrian safety application using bluetooth low energy. In *Proceedings of the International Conference on Research in Adaptive and Convergent Systems* (pp. 160-165).
- Piyare, R., & Tazil, M. (2011, June). Bluetooth based home automation system using cell phone. In *2011 IEEE 15th International Symposium on Consumer Electronics (ISCE)* (pp. 192-195). IEEE. 1-4.
- Rizzi, M., Ferrari, P., Flammini, A., Sisinni, E., & Gidlund, M. (2017, May). Using LoRa for industrial wireless networks. In *2017 IEEE 13th international workshop on factory communication systems (WFCS)* (pp. 1-4). IEEE.
- Shen, W., Yin, B., Cao, X., Cai, L. X., & Cheng, Y. (2016). Secure device-to-device communications over WiFi direct. *IEEE Network*, 30(5), 4-9..
- Singh, I., & Singh, N. P. (2018). Coverage and capacity analysis of relay-based device-to-device communications underlaid cellular networks. *Engineering Science and Technology, an International Journal*, 21(5), 834-842..
<https://doi.org/10.1016/j.jestch.2018.07.011>
- Sun, S., Gao, Q., Chen, W., Zhao, R., & Peng, Y. (2015). Recent progress of long-term evolution device-to-device in third-generation partnership project standardisation. *IET Communications*, 9(3), 412-420. <https://doi.org/10.1049/iet-com.2014.0311>
- Tehrani, M. N., Uysal, M., & Yanikomeroğlu, H. (2014). Device-to-device communication in 5G cellular networks: challenges, solutions, and future directions. *IEEE Communications Magazine*, 52(5), 86-92.
- Wen, L. P., Nee, C. W., Chun, K. M., Shiang-Yen, T., & Idrus, R. (2011, April). Application of WiFi-based Indoor Positioning System in Handheld Directory System. In *5th European Computing Conference*.
- Xiang, W., Zheng, K., & Shen, X. S. (2016). 5G mobile communications. *5G Mobile Communications*, 1-691. <https://doi.org/10.1007/978-3-319-34208-5>
- Zhao, W., Lin, S., Han, J., Xu, R., & Hou, L. (2018). Design and Implementation of Smart Irrigation System Based on LoRa. *2017 IEEE Globecom Workshops, GC Wkshps 2017 - Proceedings*, 2018-Janua, 1-6.

<https://doi.org/10.1109/GLOCOMW.2017.8269115>

Zhou, Q., Zheng, K., Hou, L., Xing, J., & Xu, R. (2019). Design and implementation of open LoRa for IoT. *IEEE Access*, 7, 100649-100657.