

Design, Construction and Performance Evaluation of a Combined Coffee Dehulling and Polishing Machine

Gbabo Agidi¹, J.T Liberty², A.G Eyumah¹

¹Department of Agricultural and Bioresources Engineering, Federal University of Technology, Minna, Niger State

²Department of Agricultural and Bioresources Engineering, University of Nigeria, Nsukka, Enugu State, Nigeria

Abstract— In spite of the facts that coffee is highly economical and can boost the country's revenue, coffee production is fast declining in Nigeria and the participation of farmers has become very low. This may be attributed to inadequate processing technology as result of the high level of drudgery involve in the shelling of the coffee bean by manual method. Therefore, there is need to develop a dehulling and polishing machine that will help increase both the quality and production of coffee seed. This work was aimed at the design, construction and performance evaluation of a combined coffee bean dehulling and polishing machine. The two units—dehulling and polishing units were incorporated in a single machine in order to prevent drudgery associated with the traditional method of dehulling and separation of the hull from the dehulled coffee bean seed. The first unit of the machine consist of a hopper; through which the coffee was fed into the the machine, and dehulling cylinder; which houses the dehulling shaft that dehulls the bean. The second unit of the machine consists of the polishing drum and brushes, attached to the dehulling shaft. The performance of the machine was evaluated following optimum operating condition of the length of dehulling shaft, speed of rotation of the dehulling shaft and the rotating brushes attached to the rotating shaft in polishing unit of the machine. Based on this conditions, the worked optimally at the rate of 180kg/hr. the result showed that the performance of the machine were 56.67% and 64.66% respectively for dehulling and polishing unit. This was obtained at a dehulling head of 500rpm as the speed of the dehulling shaft.

Keywords — Coffee bean, construct, design, dehulling, processing technology, polishing

I. INTRODUCTION

Coffee plant is native to Africa; the origin of *Coffea arabica* has been traced to Ethiopia, while Robusta coffee was believed to come from Central to West Africa (Williams, 2008; Opeke, 2005; and Ngussie and Dererse, 2007). Its preparation and cultivation was first done by the Arabs; and was introduced to most parts of Africa during the colonial era (Williams, 1998). Trends in the world production of African coffee shows that annual production in the last 10 years fluctuated between 14 and 19 million (60kg) bags, with an average of about 16 million bags; and has since fallen considerably due to varied factors (Surendra, 2002).

Although Coffee is grown and exported by more than 50 developing countries, it's mainly consumed in the industrialized countries namely United States of America, Finland, Sweden, Belgium and Japan among others (Agbongiarhuoyi et al., 2006; and Daviron and Ponte, 2005). In the world market, Coffee plays a vital role in the balance of trade between developed and developing countries; being an important foreign exchange earner, contributing in varying degrees to the national income of the producing countries (Cambrony, 1992). *Arabica coffee* provides employment for a lot of people in all producing countries (Muleta, 2007); and Surendra (2002) reported that about 33 million people in 25 African countries derived their livelihoods by growing coffee in subsistence level from about 4.5 million square kilometers of land.

In Nigeria, *C. arabica* is grown mainly by small scale farmers in the highland area of Mambilla plateau in Taraba State, as well as Nasarawa, Abia, Kogi, Kwara, Ondo, and Ogun States (Williams, 2008); and it used to be one of the major cash crops constituting the backbone of Nigerian economy before the emergence and predominance of oil. Trends have shown decline in coffee production over the period between 1960 and 2008 in Nigeria; from 18,000 bags [of 60kg bag] in 1961 to 50,000 bags in 2008, with the highest production level of 95,000 bags in 1964, 1988 and 1990 (Williams, 2008). Over 80% of coffee from developing countries, particularly Nigeria, is produced by small scale farmers who lack adequate technical education and are faced with low market price leading to poor management, poor productivity and abandoned farms (Williams, 1989; Mutua, 2000; and Agbongiarhuoyi *et al.*, 2006). Arabica coffee accounted for 4% of export in Nigeria, and less than 2% of world coffee in 1989; and while other producing countries such as Ivory Coast have in recent time significantly increased their production level despite the collapse of world price of coffee, Nigeria no longer has a place at all in coffee production on a global scale (Williams, 1989).

In spite of the facts that coffee is highly economical and can boost the country's revenue, coffee production is fast declining in Nigeria and the participation of farmers has become very low (Ayoola *et al.*, 2012).

This may be attributed to inadequate processing technology as result of the high level of drudgery involve in the shelling of the coffee bean by manual method. Therefore, there is need to develop a dehulling and polishing machine that will help increase both the quality and production of coffee seed. The dehulling system breaks the coffee shell by mechanical friction. Thus, this work was aimed at the design, construction and performance evaluation of a combined coffee dehulling and polishing machine.

II. MATERIALS AND METHODS

A. Major Parts of the Machine

The major parts of the constructed machine were; frame, hopper, dehulling and polishing drum and auger.

- i. *Frame*: it was designed with an angle iron of 40 x 40mm cut to length of 800 x 200mm to form the top resting platform for the machine's cylinder and bearings. The same angle iron was cut to a length of 600mm to form standing legs for the frame.
- ii. *Hopper*: was made up of mild steel sheet of 1mm thickness, it serves as inlet for the coffee bean. The mild steel sheet was cut to a length of 160mm to form total length of the hopper and 200mm to form diameter of the hopper.
- iii. *Dehulling drum*: the drum was made of mild steel sheet rolled into a cylindrical shape with diameter of 75mm and total length of 450mm. mild steel was chosen for the dehulling drum design because of its strength and durability.
- iv. *Polishing drum*: it was also made of mild steel cut and rolled into a cylindrical tube of 160mm diameter with total length of 250mm.
- v. *Auger*: comprises of central shaft and square rod coiled around the auger to form a spiral ring along length of the shaft which was 1000mm (1m). The spiral ring known as auger coiled around the shaft together with the effect of rotating shaft transports the coffee bean fed into the machine along the length of the dehulling drum into the polishing drum.

B. Principle of Operation of the Machine

The combined coffee dehulling and polishing machine was made up of two units; dehulling and polishing. The coffee bean was fed through the hopper to cylindrical chamber (dehulling drum). Dehulling was achieved by rotation of the auger. Its rotating effect forces the coffee bean against the walls of the cylinder. The impact effect of the auger and cylinder on the coffee bean breaks the husk to expose the bean.

Continuous rotating effect of the auger transports the coffee bean into the second cylindrical chamber known as polishing drum.

In the polishing drum, there were sets of brushes which removed the inner coating of the dehulled bean by friction and rubbing effect as the combined effect of friction of the brushes and polishing drum walls. That is the effect that actually causes polishing to take place. In the polishing drum the coffee hull was expelled out through perforated holes made under the polishing drum, creating the hull outlet, while the polished coffee bean exits through the polished grain outlet at the end of polishing drum cylinder.

C. Design of the Machine Major Components

Design parameters: The following parameters were some physical properties of the coffee seed used for the design calculations;

Density of the seed = 1226.5kg/m²

Seed width = 6.5-9.5mm

Seed length = 10 – 18mm

The assumed machine capacity = 3kg/min = 180kg/hr

Expression of the Machine Capacity in Volumetric Rate

This was done to determine the volume of coffee seed that can be dehulled per hour

$$\rho = \frac{M}{V}; V = \frac{M}{\rho} \text{ Where } \rho = \text{density,}$$

V = volume

Density of coffee seed was obtained as 1226.5kg/m³ and assumed mass = 3kg

Therefore, Volume = 0.00254m³/min

Expressing the capacity in volumetric rate;

$$\text{Volume} \times 60\text{min} = 0.00245 \times 60 = 0.147\text{m}^3/\text{hr}$$

Determination of Screw Auger Diameter

The screw diameter was determined in order to know the actual minimum diameter required to be added to the shaft diameter. The screw diameter was determined using the formula below;

$$C_{MPH} = (D^2 - d^2) \times p \times N \times 60 \text{ Where,}$$

C_{MPH} = capacity of the machine (m³/hr) = 0.147m³/hr

d = diameter of the shaft=25mm=0.025m

D = diameter of the screw of auger =?

p = pitch of the auger=20mm=0.02m

N = speed of the auger = 500

Substitute the values into the above formula;

$$0.147 = (D^2 - 0.025^2) \times 0.02 \times 500 \times 60$$

$$0.147 = (D^2 - 0.025^2) \times 600$$

$$0.147 = (600D^2 - 6.25 \times 10^{-4} \times 600)$$

$$0.147 = 600D^2 - 0.375$$

$$600D^2 = 0.147 + 0.375$$

$$D = \sqrt{8.7 \times 10^{-4}} = 0.0295m$$

Design of Shaft

The shaft is a rotating machine element used to transmit power from one point to another. The shaft was designed on the basis of strength, rigidity and stiffness. When designing the shaft, it was taken into consideration that it may be subjected to twisting and bending moment. The formula used for the shaft design was;

$$\sigma = \frac{16T}{\pi d^3}; d = \sqrt[3]{\frac{16T}{\sigma}} \quad \text{Where,}$$

d = shaft diameter (mm) = ?

T = torque of the shaft (Nm) = 36.287Nm

σ = maximum permissible work stress (N/m)

$$\therefore d = \sqrt[3]{\frac{16 \times 36.287 \times 10^3}{28\pi}} = \sqrt[3]{6600.29} = 18.758mm$$

For factor of safety, 20% of the calculated diameter was added to the calculated shaft diameter;

$$\frac{20}{100} \times 18.758 = 3.75$$

Therefore, the total shaft diameter = 18.758 + 3.75 = 22.509mm

25mm diameter was chosen for the design by standard

Torsional Deflection of the Shaft

The torsional deflection of the shaft was determined to know the angle of deviation of the shaft and to ensure minimal angle of deviation. It was determined thus;

$$\alpha = \frac{584l}{D^4} \quad \text{Where } \alpha = \text{angular shaft deflection}$$

l = length of the shaft = 1000mm

D = modulus elasticity of steel = 80000N/mm

$$\text{But } D = 2.26 \times \sqrt[4]{\tau}; \tau = \left(\frac{25}{2.26}\right)^4 = 14973.60N/mm$$

$$\alpha = \frac{584 \times 14973.60 \times 1000}{(25)^4 \times 80000} = \frac{1}{3.125 \times 10^{10}} = 0.28^\circ$$

Power Requirement of the Shaft

i. Power required to drive shaft

$P_s = W_s \times R_s$ Where W_s = weight of the shaft

R_s = radius of shaft

W_s = mass \times gravity

Mass of the shaft = 3.85kg

$$W_s = 3.85 \times 9.81 = 37.77N$$

$$R_s = \frac{D}{2} = \frac{0.0295}{2} = 0.0148m$$

$$P_s = 37.77 \times 0.0148 = 0.558W = 0.000559kW$$

ii. Power required to dehull the coffee seed

$P_h = T\omega$ Where

T = torque of the shaft = 36.287Nm

ω = angular speed of the shaft = 52.30

$$P_h = 36.287 \times 52.36 = 1.899kW$$

iii. Power required driving the pulley

$P_p = W_p \times R_p$ Where,

W_p = weight of the pulley

R_p = radius of the pulley

Mass of the pulley = 3.6kg

$$W = mg = 3.6 \times 9.81 = 35.316N$$

$$P_p = 35.316 \times 0.09 = 0.0032kW$$

Total power = $P_s + P_h + P_p$

$$= 0.00559 + 1.899 + 0.0032 = 1.9027kW$$

Therefore, 3hp electric motor was used for the design

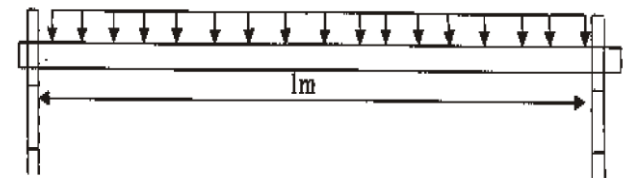

Determination of Shear Forces Reactions at the Bearings and Bending Moment

Where, mass of shaft = 3.85kg

Weight = per unit length of the shaft = $W = mg$

$$W = \frac{3.85 \times 9.81}{1} = 37.769N/m$$

$B_M C = \frac{wxl}{8}$ Where $B_M C$ is the bending moment at the centre of the shaft

$$B_M C = \frac{37.769 \times 1}{8} = 4.72 Nm$$

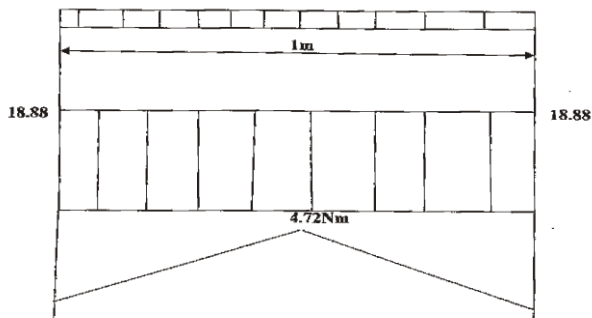

D. Construction of the Machine

All parts of the combined coffee dehulling machine were constructed from stainless steel material, except the main frame that was developed from mild steel. Stainless steel was used to construct the dehulling cylinder and polishing drum for hygienic and its resistance to corrosion purposes.

E. Performance Evaluation of the Machine

6kg of coffee bean was used to test the constructed machine. The sample was equally divided into two parts, each 3kg. The machine was initially test-run under no load condition using a motor of 3hp with speed 1500rpm and shaft speed of 500rpm. This was done to assess the smoothness of the machine parts. After this was done, the performance test was as well conducted.

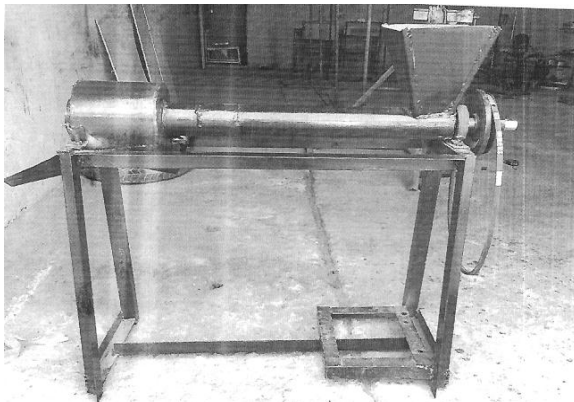

Fig1: Front View of the Combined Coffee Dehulling and Polishing Machine

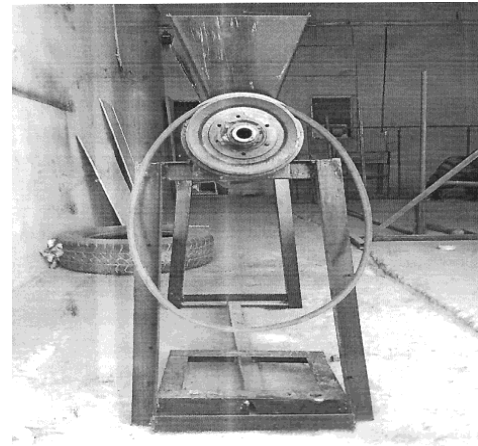

Fig2: Side View of the Constructed Machine

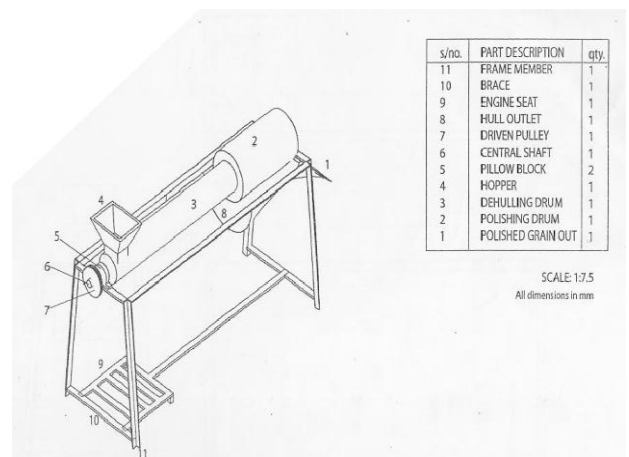

Fig3: Exploded View Machine

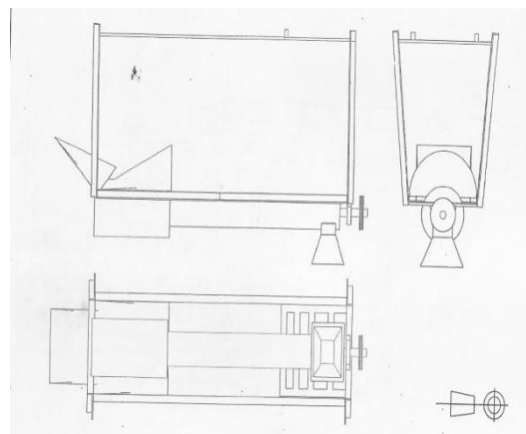

Fig4: Orthographic View of the Dehulling and Polishing Machine

III. RESULTS AND DISCUSSION

First Sample Tested;

Total mass dehulled = 3kg
 Dehulled coffee bean = 1.7kg
 Mass of the hull = 0.51kg
 Mass of undeulled = total mass of coffee bean – (dehulled coffee bean + mass of the hull)
 = 3 – (1.7 + 0.51) = 3-2.21 = 0.79

$$\text{Dehulling efficiency} = \frac{\text{mass of dehulled coffee bean}}{\text{total mass of coffee bean dehulled}} \times 100$$

$$= \frac{1.7 \times 100}{3} = 56.67\%$$

Second Sample Tested;

Total mass dehulled = 3kg
 Dehulled coffee bean = 1.94kg
 Mass of the hull = 0.55kg
 Mass of undeulled = total mass of coffee bean-(dehulled coffee bean + mass of the hull)
 = 3-(1.94+0.55) = 3 – 2.49 = 0.51kg

$$\therefore \text{Dehulling efficiency} = \frac{1.94}{3} \times 100 = 64.66\%$$

Table1: Result Presentation

Mass of Sample	Dehulling Time	Dehulling Efficiency
3kg	78seconds	56.67
3kg	81seconds	64.66
Average	79.5seconds	60.67

The variation in dehulling time was owing to variation in hardness of the coffee seed. Power was loss as result of creeping and slipping effect of the belt in between the pulleys.

IV. CONCLUSION AND RECOMMENDATION

The dehulling efficiencies of the machine were 56.67% at an interval of 78seconds and 64.66% at a time interval of 81seconds respectively. The machine will help reduce the time required to dehull coffee bean. The machine is energy saving, efficient, accessible and requires lesser main power for its operation. However, the dehulling chamber should be tilted in order to allow the seeds fall under gravity into the machine.

REFERENCES

- [1] Agbongiarhuoyi, A.E., O.O. Oduwole, and R.A. Sanusi (2006) Technology Transfer and Adoption of Coffee Coppicing in Kogi State, Nigeria. In; Proceeding of the 21st. International Conference on Coffee Science Organized by ASIC – Association Scientifique International Du Café; Held in Montpellier France 11 15th September 2006. Available on-line @ www.asicccage.org.
- [2] Ayoola, J.B., Ayoola, G.B and Ladele, A.A. An Assessment of Factors constraining Coffee Production and Marketing in Nigeria. International Journal of Science and Nature. 3(3) 678-683
- [3] Cambrony, H.R (1992) The Tropical Agriculturist Coffee Growing. Published by CTA Macmillan, Malaysia. Pp 1 -2.
- [4] Daviron, B. and S. Ponte (2005) The Coffee Paradox. Published by Zed Books Ltd; In Association with CTA, New York pp. 50 - 53.
- [5] Khurmi, R.S, Gupta, J.K (2005). Machine Design. Eurasia ublishing house (PVT) Ltd, Nagar, New Delhi.
- [6] Muleta, D. (2007). Microbial Inputs in Coffee (Coffea Arabica) Production Systems, South Western Ethiopia. Implication for Promotion of Biofertilizers and Biocontrol Agents. Doctoral Thesis, Swedish University of Agricultural Sciences.
- [7] Mutua J. (2000). Post Harvest Handling and Processing of Green Coffee in African Countries
- [8] Ngussie, E. and T. Derese (2007) Knowledge and Perception of Farmers Regarding Improved Coffee Technologies: The Case of Mana District in South – Western Ethiopia. In: The Proceedings of African Crop Science Conference, Vol. 8, El-Miria, Egypt, October 2007. pp 1403 – 1407.
- [9] Opeke, L.K. (2005) Tropical Commodity Tree Crops. 2nd Edition, Spectrum Books Ltd; Ibadan pp. 258 – 267, 272 – 282. Progress in Tree Crop Research, 2nd , Published by Cocoa Research Institute of Nigeria (CRIN) Ibadan. Pp. 127 – 140.
- [10] Surendra, K. (2002) .Coffee in Africa, Impacts and Issues of Low Price Crisis, Discussion Paper for Ministerial Conference Held in Malabo, Equitorial Guinea, October, 2002. Prepared for Inter –Africa Coffee Organization. Pp 6 – 13.
- [11] William, J.A. (2008) Coffee Production Manual (Hand Book) Published by Cocoa Research Institute of Nigeria (CRIN) Ibadan pp 5 – 20.
- [12] Williams, J.A. (1989) Coffee Breeding in Nigeria. In: Progress in Tree Crop Research, 2nd Edition, Published by Cocoa Research Institute of Nigeria (CRIN) Ibadan. Pp. 127 – 140.