



Re-emergence of Indigeneity in transformed Layouts in Urban Public Housing in Nigeria

Abubakar Danladi Isah

Department of Architecture, Faculty of Built Environment, Universiti Teknologi Malaysia
Email: arcmuzaifa@futm.inna.edu.ng

Tareef Hayat Khan

Pusat Kajian Alam Bina Melayu (KALAM), Institute for Smart Infrastructure and Innovative Construction (ISIIC), Faculty of Built Environment (FBE), Universiti Teknologi Malaysia (UTM)
Email: tareef@utm.my

History:

Received: 2 December 2015

Accepted: 10 January 2016

Available Online: 30 January 2016

Keywords:

Design, Housing Transformation, Indigeneity, Mainstream Cultural Values.

Corresponding Author Contact:

+607-5537626

DOI:

10.11113/ijbes.v3.n1.104

ABSTRACT

In contrast to the one whole homogenous configuration provided by developers that has often proved ineffective overtime, transformed public housing units are widespread in developing cities. Though transformation is a natural phenomenon of inhabitation, its various levels and degree can have implicit values. In recent times in Nigeria, heterogeneous spatial patterns of transformed houses in public housing estates has given empirical evidence of essentially inevitable reflection of culture sensitivity as hypothesized by previous studies. That hints that the mainstream sustainable values were probably ignored during design process. This study attempted to connect that possible missing link. To achieve that aim, it developed two objectives. First, is to identify core values behind space layouts in the mainstream. Then, to examine how they exist in the transformed layout as reflected at communal origins. It investigated on 42 transformed units in selected urban Public housings neighborhoods via a stratified conditional sampling conducted in five states of Nigeria. Qualitative methods were adopted for data analysis. After identifying the core ethnic groups in the region, their social indicators with regards to space use were determined through ethnographic principles. These indicators were then operationally defined, and used as a tool to examine users' motivations in the transformation process in urban context. Spatial pattern analysis, by using gamma delineation, revealed the social content in the transformations after comparing initial design and the transformed spatial configurations. The outcome signified the mainstream cultural values in the transformation process hence in Public housing design. The convergence of mainstream values into urban transformed layouts suggested that they cannot be ignored during design process. The outcome of this research might be useful in designing sustainable public housings in culture sensitive environments, better still a guide to Architects and developers in this regard.

1. Introduction

Public housing transformation in developing countries is described by Tipple (2000) as a housing supply mechanism with beneficial features, yet negatively perceived by development authorities. At the moment, the authorities choose to ignore the inspiring indicators of housing transformation, and the benefits that could have afforded optimization of users' performance, raise housing values, minimize cost to owners, and overall enhancement in users' satisfaction.

The knowledge about these contexts- i.e. establishing indicators that inspire Public housing transformation and linking them with cultural background remain unharnessed. Furthermore focusing on culture specific context creates the bedrock for culture inclusiveness which is critical in housing design (Rappoport, 2000). This study hence attempted to further extend knowledge on transformed public housing,

focusing on culture sensitive issues which the communities carry over from their previous experiences in the mainstream country life. This has become crucial as user's experience is perceived to enrich design considerations thus, providing design paradigms with potentials towards bridging the gap between root and urban space uses.

Against this backdrop, the study focused on Public housing units, which were probably executed with the assumption that potential users are of equivalent status, income level, household composition, and similar housing consumption requirements, while ignoring their socio-cultural background. Therefore these designs seem disconnected with the socio-cultural life of potential inhabitants. Consequently, the houses examined in this study targeted typical mass public housing in Northern Nigeria. In the process transformed public housing units where investigated towards establishing the phenomenon as well as culture related space uses that bond inhabitants with their root.

2. Background

In the first part of the background study, transformation as user responsiveness to desired housing deficiencies was related towards improving housing consumption by impacting cultural requirements. At this stage improved livability of households was related with housing transformation process. Next, it described the reflection of culture in the operational activities that bound social settings with building structures particularly in public housing units where it is often excluded in initial homogeneous design. Thirdly, it pointed to the inconsistency in provisions and user requirements calling for a review of initial design through accommodating both etic and emic housing design perspectives. Overall, this section relates the research gap and defines the objectives of the study.

2.1 *Improving household livability by means of housing transformation*

Existing prototype housing pattern has failed to offer solutions to Nigerian housing problems (Olotuah and Bobadoye, 2011). Housing designers have opined that at the initial design stage, potential users' needs cannot be considered as they are usually unknown. Yet scholars have argued in support of the inevitability of housing transformation in housing consumption process, which provides a platform in rethinking design solutions. Households constantly search for answers to housing stability due to disequilibrium occasionally witnessed during the consumption process thus transform to survive (Khan, 2014b). They search continuously for available options in line with the disequilibrium model on residential mobility (Clark and Ledwith, 2005). The process aligns with the dynamism in household structure and their needs which makes housing provision a continuous process even after occupation as a growing structure. The situation is often aggravated by the flexibility in the socio economic status of inhabitants. Thus, the need to envisage future changes at conception in order to improve household livability becomes essential. As internal household behavior of survival, freedom and emotional fulfilment is expressed in tune with choice theory as outlined by Glasser (Glasser, 1998). Therefore, ignoring the benefits inherent in the transformation process and considering it illegal undermines the value of the property. This act leaves these houses serving as mere transient shelter for households in desperate need of accommodation to stay for a while and plan for a more permanent shelter where their desires can be achieved. In addition qualitative and orderly housing transformation is usually hindered by the availability of fund (Isah et al., 2014). Despite which inhabitant insist in fulfilling their long life agitations. However, housing transformation benefits improves users' efficacy and housing consumption (Seek, 1983). More so, housing transformation is significant to housing sustainability (Tipple et al., 2004). Recent research on transformation has been focused on the practice with the search for design themes and layout patterns in the cultural and physical spheres used to implicitly define the cultural character of the inhabitants' desire for housing consumption (Khan, 2014a). Therefore, user's responsiveness to dwelling territorial control where standards are flexible allowing for users' participation irrespective of their affluence, culture and level of education are significant housing activities universally recognized (Khan, 2014b).

2.2 *Optimizing performance of Building operation through cultural bond*

Building structure and the social setting as well as the operational activities surrounding its performance remains bounded with the success in their union used to access the satisfaction derived by users.

Generations of scholars have emphasized the need for cultural reflection in buildings towards its sustainability. For instance, Rapoport (2000) advocates for culture specificity in determining the design of buildings in particular environments, in order not to undermine the history, cultural traditions and forms of design (Rapoport, 1983) linked to the background of the beneficiaries. Similarly, Davis (2000) ascribed building culture to compose of specific configurations of knowledge, establishments engaged in the building activities, the laws guiding the provision and operation as well as the building products themselves specific to time and particular to a place. The challenge however has been in the quest for attainment of higher levels of housing civilization where authorities in developing societies with long time housing cultural history tend to imbibe new building culture that is alien to its inhabitants, while ignoring the existing housing cultural practices. For instance, the long-time Africa's history of space recognition and interaction (Prussin, 1974) reflects symbolism, coherency linking principles and underlying meaning that describes their space use which cannot be undermined. Blindly adopting other cultures' design does not proffer solutions to culture sensitive communities housing problems (Khan et al., 2015). In fact, the intangibles of building that provides its meaning and symbolizes it are usually significantly focused on cultured communities, than the tangible materials of blocks, bricks, windows, concrete and walls therefore, genuine uniqueness are derived from the immaterial constituents (Rusalic, 2009). In this regard promoting indigenusness in dwellings is crucial as the building provision in achieving user satisfaction.

However, researchers have questioned the applicability of vernacular concepts in urban housing design, yet a category of urban dwellers demand for the right to live their local life in the cities and should be accommodated. In this regard Khan (2014b) stated that not all traditional values might be applicable in the urban setting where standardization is required. Therefore, there is the need to determine the threshold from users' spatial experience and perspective. To this effect Isah and Khan (2015) outlined adaptive considerations of sustainable design elements to include relating outdoor and indoor space use lifestyles and social cohesion of household in space organization. They further stated as significant streamlining value system with space use as well as screening household chores from external vision.

2.3 *Growing investment in Public Housing and rethinking the design concept*

On the overall, investment by government and private sector in the provision of public housing to bridge the existing gap in housing shortage witnessed in Nigeria has been on the rise. Consequently the delivery of large scale proto-type core housing and apartments in state capitals and satellite towns. Several existing government policies and practices have supported the public housing approach in housing delivery system. However, the failure of previous housing policies (Ikejiofor, 1999), more so that it is attributed to culture exclusion (Ibem et al., 2011; Jiboye, 2004) necessitates the new approach of research into user transformed layouts in searching for solutions to deteriorating housing problems. In this regard this study examined users' experience in public housing space transformation relating it to the root so as to establish the space use in attribution to cultural backgrounds. This is to further reveal the inseparable cultural values inherent in inhabitants' association with their dwellings. This is significant in rethinking the design concept as it would direct layout conception.

2.4 Design Implication and the need for cultural character integration

Stuck at a crossroad with inconsistency of provisions and requirements, Public housing designs require a cultural paradigm that will ensure its sustainability. Thus recent public housing studies are focused on the importance of cultural character in buildings (Chiu, 2004; Maina, 2013). Therefore, the comprehension of cultural character in space use and evaluation of standards to accommodate it becomes unavoidable. Design as solutions to problems associated with housing needs, should comprehend details of these needs in order to proffer solutions that accommodate user's efficacy. The consequence is the critical review of design options adopted for public housing estates. Interestingly, cultural perspective in housing design relates the need to comprehend contextual human behavior in space usage (Berry et. al., 1992). Doing, this will assure the consideration of indigenous situations in sustainability stance in the development of housing as emphasized by Isah and Khan (Isah and Khan, 2015). According to Isah et. al., (2015b), designs that results from the transformation process are influenced by the lifestyle of the households particularly with regards to family structure and social activities. This approach assures user participation which is regarded as significant in sustainable housing development (Isah, 2012).

2.5 Spatial Paradigm: Between Homogeneity and Heterogeneity

The existing principles adopted in public housing design at the study settings produces homogenous products presumed to be completed before occupation. However, the design being inconsistent with time as the needs and desires of potential inhabitants rapidly changes due to inflicted user initiated transformation, therefore undermining the continuous initial presumption of completeness in the formation of the units. Moreover, inhabitants' desire grows and changes overtime which also requires changes to be made to spatial configurations of the home as well. This Tipple et al. (2004), refers to as "varieties out of uniformity", where uniform designs translates into a heterogeneous forms due to growing changes in the house, households size, occupants, tenure, use, house value and housing cost.

Accordingly, overtime the configurations depict users' desires, reflecting the required housing consumption based on family norms and culture. Inevitably, households utilises the resources at their disposal to create living spaces that satisfies their needs, irrespective of the formation which in most cases does not retain the initial homogeneous design. Consequently, the heterogeneous compositions attained reflect several factors that also distinguish the households from one another. Invariably, the phenomenon evokes the changing urban spatial paradigm in developing and culturally sensitive communities that can no longer be ignored. In attaining this usually, the link with the root combined with their long time engagement with urban environment and peer group's influence directs the layout configuration in a technologically driven era (Isah et. al., 2015a).

2.6 Etic and Emic Paradigm, the search for design solutions

In a growing momentum, social scientists have criticized the spatial ordering of spaces by professional designers who emphasis on formal and visual aspects that are devoid of concentration on the relationship between spatial devices and the lives of inhabitants (Lym, 1980). As a result, the wisdom and benefits of indigenouness are seldom discouraged with associated negative perception resulting in the lack of understanding of the content and its acceptance (Asomani-Boateng,

2011). In effect the act poses the greatest challenge to the development of indigenous forms. Fundamentally, socio-cultural factors governing social settlements that has shaped vernacular physical and spatial environments have conflicted with contemporary housing styles (King, 1983) in urban settings as cities evolves and inhabitants retaining strong link with their roots (Mberu, 2005). Accordingly, recent housing research has witnessed a persistent demand for indigenous culture consideration in urban housing design. Invariably, initial housing composition and later transformations are characterized as reproduction of cultural relations in a progressive housing civilization (Franklin, 2006).

So, people search and observe their environment in obtaining useful information about their surroundings (Kaplan and Kaplan, 1982) that reshapes their spatial character. Although both in the etic and emic concepts of housing space use adopted by designers, they intuitively focus on developing an enduring space experience of potential building inhabitants; the indigenous laymen designers realize spatial orders by embarking on lifelong journeying, concentrating on spatializing inhabitants' livability while the professional designers emphasize on the formal and visual aspects of building architecture (Lym, 1980). Therein lies' the conflict that led to the emergence of culture responsive spatial paradigm to meets users' housing consumption and a void that requires professional perfection, which this study advocates and attempts to fill by examining users experience in transforming public housing designs to include their cultural desires. Thus, it necessitates the need for harmonizing cultural demands and urban ideals in the search for solutions to housing problems. A paradigm presumed to provide sustainability to dwellings in culture sensitive communities.

2.7 Knowledge gap and research direction

Arguably, the above literature analysis has demonstrated that mainstream values of communities need to be integrated in public housing to maintain sustainability. Inversely, inhabitants make temporary or dismountable adjustment in estates built for leasing, while upon occupation and possession rapid adjustments are embarked upon by owners who occupy bought estates leading to heterogeneous formations. Yet authorities often ignore the benefits users derive in housing transformation process, therefore undermining the values therein. The review has also shown that expert designers seem to promote formal and visual preference in design. Similarly, authorities emphasize adherence to standards while ignoring users' responsiveness to cultural livability. Although they emphasize standards, their passiveness in enforcement allows for uncontrolled transformation leading to chaotic formations. The persistence of the situation is worrisome and considered a path to harness by this research.

Therefore this study adopts the evaluative approach by directing harmonious synthesis of cultured spatial character and urban design standards in housing forms. This approach follows Tipple's acknowledgement of concentrating on both general processes and city specific issues related to transformation so as to account for convergences and divergences in the diversities of cities and its people. Thus the following assertions are deduced from the forgone discussion. Housing consumption in homogenous settings is devoid of households' norms and culture.

Reflecting indigenouness in design has been demanded by both researchers and community dwellers. Lay designers and professionals conceive the concept of livability differently, hence a need for

harmonious synthesis of cultured spatial character and urban design standards in housing forms.

In light of the above, the study attempt to uncover core space use values from mainstream that address the situation in order to improve design and optimize inhabitants operation, housing values and performance. The above literature analysis has shown that long time history and values such as witnessed in Africa, continuously connect urban inhabitants with their origin. Therein lay the desired meaning and symbol of culture with trio dimension to housing concept. First, it enables the understanding of the conflict between vernacular and contemporary housing styles. Second, it identifies the gap between provision and desire for spaces whose solution does not exist in other cultures. Third, housing transformation has provided improvement in the efficacy of households' livability.

This study belongs to the third dimension and subsequently the research strand is essentially considered to achieve two objectives. First, to identify core values behind space layouts in the mainstream root. Then, to examine how they exist in the transformed layout as reflected at communal origins. Hence, to search for design themes and layout patterns can be the possible applications afterwards.

3. Methodology

Using a purposive approach, this study examined forty two (42) houses in selected public housings across 5 states reflecting the six major ethnic groups in northern Nigeria namely, Hausa, Fulani, Kanuri, Nupe, Gbagyi, and Tiv (Mustapha, 2006). The research process involved two stages corresponding to the two objectives; first stage included identifying core space use attributes at the dwellings in the mainstream at countryside through micro-ethnography. The second stage adopted qualitative techniques through comparative analysis followed by development of themes in order to search for spatial patterns of transformed units that is rooted in the mainstream.

3.1 Stages

3.1.1 First Stage: Micro-ethnography

Identifying core indicators of space use in dwellings common to the major ethnic groups: This stage comprised of micro-ethnography intended to identify the core cultural indicators of space use in dwellings in the countryside, and the associated space use attributes common to the major ethnic groups in the study area. This was achieved through researchers' engagement with the setting as participant observer.

3.1.2 Second stage: Qualitative analysis

Examining how cultural indicators exist in the transformed layouts: In order to further evaluate the impact of cultural indicators as well search for design themes and patterns in the transformed layout, the second stage of the research assessed the transformed layouts in the urban setting in relation to the communal space use identified at the first stage.

3.2 Basic Elements for Comparison

Space uses patterns in typical compounds inhabited at the root as well as in transformed layouts were observed focusing on domestic chores as households relate with their dwelling spaces. The essence was to enable

Table 1 Basic elements for comparison

Dimensions	Description of measures	Comparable Spaces in	
		Dwellings at Root	Transformed layouts
Core Spaces	Central areas that are the nucleus of houses usually public spaces that socially integrate households	Reception, Outdoor relaxation space	Porch
Linkages	Connections between core spaces and ancillary spaces	Courtyards (Outer, Inner)	Lobbies/ Corridors, Inner Courtyard
Ancillary Spaces	Usually (but not limited to) private spaces that provide habitation tendencies to households	Bedrooms, Kitchen, and Toilets	

research process to qualitatively observe and compare the spatial relationships in the configurations. The observation was illustrated using the principles of gamma diagram to qualitatively delineate space uses. Three dimensions were thus adopted as measures and thus presented below as well as in Table 1.

Gamma Diagram that measures relationships between social life and built environment using spatial configurations approach was adopted to explore relationship between social behavior and space. The principle of Gamma Diagram introduced by Hillier and Hanson (1984) nullifies the effect of size and shape of the spaces, and focuses on the connection between them in order to look for hierarchy, connectedness, and depth of the spaces. Focus was on network of activities as it reflects level of space integration related to access, movement and function. Typical layout configuration, two each from the ethnic root and from the urban transformed layouts were presented as below.

4. Examples of dwellings from Root and from Urban transformed layouts

4.1 Examples of Layouts of dwellings at the root

Analytically, the root's spatial layout was characterized with a pattern that included unordered outdoor area bounded by the entrance at one end and an arbitrary line with the street at the other end (Figure 1). Then a symbolic entrance hall that opens to a forecourt as the first habitation and an inner court as the next habitable area. Families' spaces comprise of rooms for sleeping, cooking, storage all opening to a courtyard where domestic activities are carried out (Figure 2). Gamma diagram (Figure 3) shows the connectedness and depth of the spaces. There seems to be a reflection of the three dimensions with the configuration reflecting the social lifestyle of its inhabitants.

Similar example from another group, i.e Tiv, is illustrated in the following figures. Figure 4 shows the layout, Figure 5 shows the inner spaces, and Figure 6 shows the Gamma diagram of the spaces.

4.2 Examples of typical transformed layout of urban public housing

Undoubtedly, transformation practice in these public housing initiated by governments was observed as salient issue that was being ignored. Inhabitants found out that initial units could not conform to the domestic chores of inhabitants, hence they embarked on transformation. Across the housing neighborhoods studied



Figure 1: Layout of a Gbagyi house.



Figure 2: A Gbagyi indigenous house in Kpamuko-Maitumbi Minna, Nigeria. (a) Outer courtyard, (b) Formal Entrance, (c) Inner courtyard

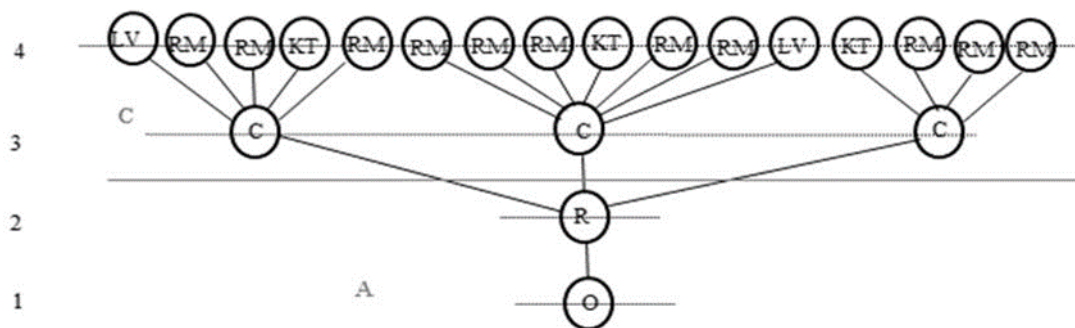

Legend: A: Core space, C: Ancillary Space, RM: Room, SH: Shower, LV: Lavatory, C: Courtyard, O: Outdoor, KT: Kitchen, R: Reception

Figure 3: Gamma diagram of a typical Gbagyi house

concentration was on activities and the space use pattern as initial designs were compared with transformed layouts. Two examples out of the 42 transformed houses studied were illustrated in order to show the space linkages in the transformed layouts. The two instances (Figure 7) significantly show enclosed functional spaces around a courtyard, which were carved out during transformation. In particular, the adjustment shown in second case in Figure 10b include fencing the compound which enabled the creation of fore courtyard, inner courtyard and a side entrance describing movement and flow pattern within the compound. These provisions in the transformed layout can be related to the

situation at the root. Therefore, the outcome relates the significance of social lifestyle in space use pattern.

5. Findings

Consequently, Outdoor relaxation, Sleeping rooms, Cooking activity, Domestic chores were the elements seen to have been given high significance by the transformers as these attributes of social lifestyle of inhabitants commonly found at the root were compromised in the initial provisions. Spatial pattern analysis revealed through gamma



Figure 4: Layout of a Tiv house



Figure 5: A Tiv compound in Makurdi, Nigeria: (a) Formal Entrance (b) Courtyard (c) Sit out area

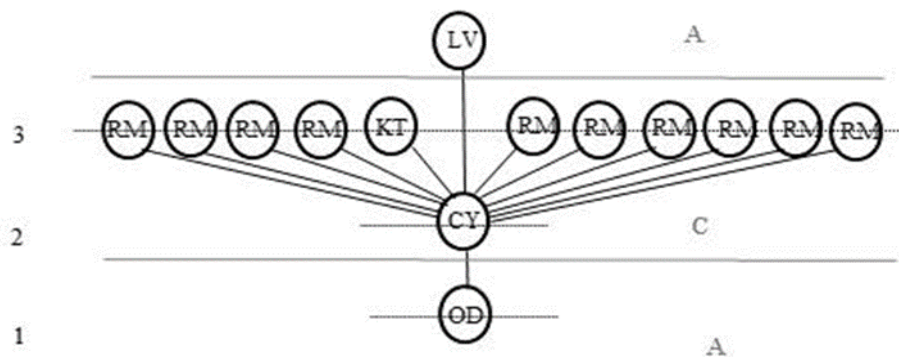

Legend: A: Core space, C: Ancillary Space, RM: Room, SH: Shower, LV: Lavatory, C: Courtyard, O: Outdoor, KT: Kitchen, R: Reception

Figure 6: Gamma diagram of a typical Tiv house

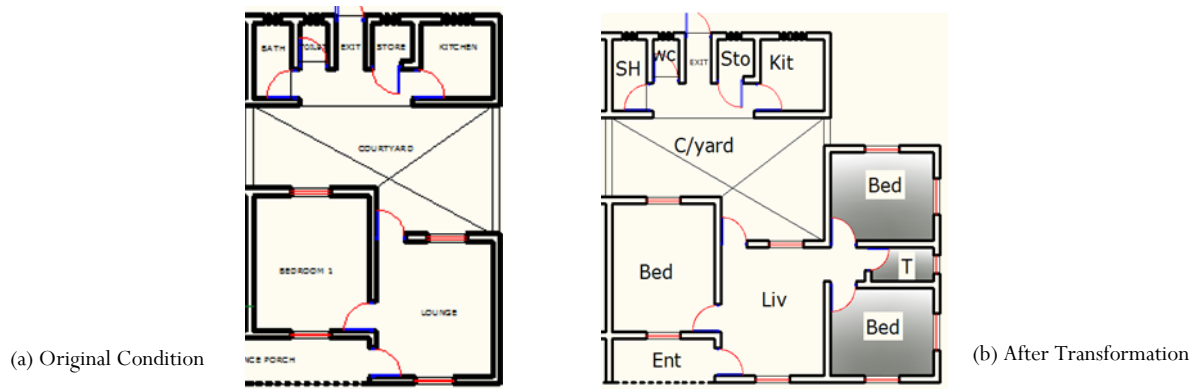

Figure 7: Layout of a typical one-bedroom public housing unit



Figure 8: View of the unit

diagrams showed that the distinguishable public and private spaces, as well as the linkages appeared after transformation. These features with common conceptual outlook exhibited consistency across the samples studied, hence tangible for generalization. Consequently, these illuminated two major outcomes for the study in terms of specificity of space usage, and certain philosophical concepts that signified the particular patterns of transformations. In effect functional space use pattern at the root re-surfaced portraying the significance of the transformation process. We can look back at those components again.

5.1 Major Re-emergences

a. Courtyard(s)

The transformed layout had courtyards introduced as part of the transformation process. Courtyards are the most significant part at the residential unit. In the root, it is still the single most important space. This is the space where family members traditionally intermingle, as well as perform different household activities. However the study found that the initial public housing design layouts did not provide courtyard, and as a result, the users has to improvise the layout by themselves as shown in (Fig 7b). Even some of them managed to get two courtyards in one unit (Fig 10b), with the outer one mainly dedicated for males, and the internal courtyard are mainly for female and children, reminiscent to the root culture. That affirms the spatial link of urban dwellers with their house that was however been ignored in the initial design layout of urban public housings. The re-emergence of courtyards in urban public housing layout signified the importance of spaces which activities related as a practiced at the root.

b. Reception

The reception areas in the root are mainly for public usage, where usually the males interact socially. The outdoor relaxation spaces are also located over there for males to gather around (Fig 2c, 5c). The urban public housing units initially did not provide any such space, but the users seem to recreate and re-modified the space by using boundary walls (Fig 7b, 10b) and integrating it with the fore courtyard. It seems that the resident did try their best to enforce this option because the value of males gathering means a lot in their social life. In fact it shows the gender preference in spaces usage which is inherent in the social lifestyle of the inhabitants. In this regard, the space provided for male visitors' reception, gathering during social occasions and male inhabitants' outdoor relaxation. Usually this is traditionally linked with the living room which provides spaces for the indoor performances of these functions.

5.2 Significance of Transformation practices

It is not only in one or two occasions, but significantly in most examples the re-emergences occurred. The transformed layouts showed consistency in the patterns that re-introduced forecourt, entrance reception area, side exit, inner court, service enclosures such as kitchen detached from main building and opening to the inner court, separation of older boys apartment, additional family living rooms, and attachment of private toilets to rooms are modified and harmonized space uses that characterize evolving indigenous urban housing architecture. Though it was not easy to provide all of them in every occasion due to the limitations of the site, but the re-emergence of courtyard and receptions seemed inevitable.

The value underlying the cultural reflection of urban housing lies in the unbroken linkage of urban residents with their roots (Mberu, 2005), a common model practiced in culturally centered settlements is therefore discovered. In this regard transformed housings appear with unintentional layout patterns that depict a common direction as seen at the root. Therefore, this outcome is indicative of the significance in the cultural character of dwellings to its inhabitants.

The study uncovered the significance of socio-cultural attributes in influencing transformation decision. Hence, a formal practice that streamlines housing delivery mechanism with the mainstream values of inhabitants. Inhabitants' values are critical features in sustainable housing delivery that should therefore be promoted. This is vital as initial design configuration greatly hindered the successful practice of transformation thereby relegating the quality of the transformed product. Perhaps accounting for the reason why the benefits are not comprehended despite the persistence shown by the inhabitants. Essentially, the inevitability of transformation and the useful benefits inherent can no longer be ignored in attaining sustainable public housing design.

6. Conclusion

Apparently, cultural space uses in Public housings were astonishingly observed to be modified by inhabitants in order to reflect the root space concepts. The findings of the research have applicable usability to various purposes. First, it identified peculiarities in the evolving structure appearing as attributes reflecting culture responsive dwelling features. Second, urban architectural spatial layout forms that advances indigenous housing features emerges, and would encourage policies and aid developers to create innovative culture responsive public housing designs as a mechanism in housing delivery scheme.

The quest for culture responsive design has been acknowledged, but the perfection and sustainability remains undiscovered. The model in the transformed product of public housing adjustment if improved with professional outlook and supported by policies, will resolve urban housing quality and improve housing consumption while easing the delivery mechanism. The contextual cultural character that evolves would reflect in the housing units redirecting transformation practices towards positive outcomes rather than pronounced negativity. Such is the indigenous urban house promoted by the outcome of this study. Further research could therefore focus on the standardization of transformation attributes and products in advancing the perfection of the process.

Acknowledgements:

The authors sincerely acknowledge Research Management Center (RMC) of Universiti Teknologi Malaysia (UTM), and the Ministry of Education (MOE) of the Government of Malaysia for the funding of this research through research grant no. Q.J130000.2421.03G20, Q.J130000.2509.07H37, and R.J130000.7909.4S104.

References

Asomani-Boateng, R. (2011). Borrowing from the past to sustain the present and the future: indigenous African urban forms, architecture, and sustainable urban development in contemporary Africa. *Journal of Urbanism: International Research on Placemaking and Urban Sustainability*, 4(3), 239-262.

- Berry, J. W., Poortinga, Y. H., Segall, M. H. and Dasen, P. R. 1992. *Cross-cultural Psychology*. Cambridge: Cambridge University Press.
- Chiu, R. L., (2004). Socio-cultural sustainability of housing: a conceptual exploration. *Housing, theory and society*, vol. 21,65-76.
- Clark, W. A., & Ledwith, V. (2006). Mobility, housing stress and neighbourhood contexts: Evidence from Los Angeles. *Environment and Planning A*, 38(6):1077-1093.
- Davis, H. (2000). *The culture of building*. Oxford University Press.
- Franklin, B. (2006). *Housing Transformation: Shaping the Space of Twenty First century Living*. (Vol. Volume 17) London; NewYork: Routledge.
- Glasser, W.(1998). *Choice theory: A new psychology of personal freedom*. New York:Harper Collins Publishers.
- Hillier, B. and Hanson, J. (1984) *The social logic of space*, Cambridge, Cambridge University Press.
- Ibem, E. O., Anosike, M. N. and Azuh, D. E. (2011). Challenges in public housing provision in the postindependence era in Nigeria. *International Journal of Human Sciences*. 8(2), 421-443.
- Ikejiofor, U. (1999). The God that Failed: A Critique of Public Housing in Nigeria, 1975–1995. *Habitat International*. 23(2), 177-188.
- Jiboye, A. (2004). The socio-cultural responsiveness of household size on housing quality in Osogbo, Nigeria. *Anthropologist*. 6(3), 169-174.
- Isah, A. D. (2012). Social Organisation And Spatial Configuration of Mass Housing in Nigeria: A Study of Intermediate Housing Estate in Minna, Nigeria. *Interdisciplinary Journal of Contemporary Research in Business*. 4(2), 795-805.
- Isah, A.D., Khan T. H. and Ahmad, A. S. (2014). Exploring Socio-Economic Design Implications of Public housing Transformation; The Nigerian Experience. *Applied Mechanics and Materials* Vols. 584-586, pp 211-216.
- Isah, A.D. and Khan T. H. (2015). Sustainable public housing transformation in the Convergence of Emic and Etic Paradigms. *Jurnal Teknologi*. 77(14), 33-39.
- Isah, A.D., Khan T. H. and Ahmad, A. S. (2015a). Design Implications: Impact of Socio-Physical Setting on Public Housing Transformation in Nigeria. *Journal of Management Research*. 7(2),55-70.
- Isah, A. D., Khan T. H. and Davis, H. (2015b). Identifying Contextual Attributes as Predictors of User Satisfaction: A study in Transformed Public Housings in Nigeria. *Asian Social Science*. 11(25),165-178.
- Kaplan, S. and Kaplan, R. (1982). *Cognition and Environment: Functioning in an Uncertain World*. New York: Praeger.
- Khan, T. H. (2014a). *Houses in Transformation Search for the Implicit Reasons*. Cham Heidelberg New York Dordrecht London: Springer.
- Khan, T. H. (2014b). *Living with transformation: Self-built housing in the city of Dhaka*. Cham Heidelberg New York Dordrecht London: Springer
- Khan, T. H., Isah, A. D., Anjomshoa, E. and Sabri, S. (2015). Users' Perceptions on Pedestrian Prioritized Neighborhoods: a study on Terrace Row Housing Estates in Malaysia. *International Journal of Built Environment and Sustainability*. 2(1), 29-38.
- King, A. (1983). Culture and the political economy of building form. *Habitat International*. 7(5–6), 237-248.
- Lym, G. R. (1980). *A psychology of building: how we shape and experience our structured spaces*. Englewood Cliffs: Prentice-Hall.

- Maina, J. J., (2013). Uncomfortable prototypes: Rethinking socio-cultural factors for the design of Public housing in Billiri, north east Nigeria. *Frontiers of Architectural Research*. vol. 2, 310-321.
- Mberu, B. U. (2005). Who moves and who stays? Rural out-migration in Nigeria. *Journal of Population Research*. 22(2), 141-161.
- Mustapha, A. R. (2006). Ethnic structure, inequality and governance of the public sector in Nigeria. United Nations Research Institute for Social Development.
- Olotuah, A. O. and Bobadaye, S.A. (2011). Sustainable housing provision for the urban poor: a review of public sector intervention in Nigeria. *The Built & Human Environment Review*. vol. 2, 51-63.
- Prussin, L. (1974). An introduction to indigenous African architecture. *Journal of the Society of Architectural Historians* 33(3), 182-205.
- Rapoport, A. (1983). Development, culture change and supportive design. *Habitat International*. 7(5), 249-268.
- Rapoport, A. (2000). Theory, culture and housing. *Housing, theory and society*. 17(4), 145-165.
- Rusalic, D. (2009). Making the Intangible tangible: the new Interface of Cultural heritage. (Vol. 63) Institute of Ethnography Sasa, Sanu: Belgrade.
- Seek, N. (1983). Adjusting housing consumption: improve or move. *Urban Studies*. 20(4), 455-469.
- Tipple, G. (2000). *Extending Themselves: User Initiated Transformations of Government-built Housing in Developing Countries*. Liverpool University Press.
- Tipple, A. G., Owusu, S. E. and Pritchard, C. (2004). User-initiated extensions in government-built estates in Ghana and Zimbabwe: Unconventional but effective housing supply. *Africa Today*. 51(2), 79-105.