This item was submitted to [Loughborough's Research Repository](#) by the author.
Items in Figshare are protected by copyright, with all rights reserved, unless otherwise indicated.

Human effect on twin antenna on-body for three diversity techniques at 2.4 GHz

PLEASE CITE THE PUBLISHED VERSION

PUBLISHER

IEEE © EurAAP

VERSION

AM (Accepted Manuscript)

PUBLISHER STATEMENT

This work is made available according to the conditions of the Creative Commons Attribution-NonCommercial-NoDerivatives 4.0 International (CC BY-NC-ND 4.0) licence. Full details of this licence are available at: <https://creativecommons.org/licenses/by-nc-nd/4.0/>

LICENCE

CC BY-NC-ND 4.0

REPOSITORY RECORD

Al-Saffar, Dina A.H., R.M. Edwards, Oluwaseun A. Ojerinde, C.J. Panagamuwa, and R.D. Seager. 2019. "Human Effect on Twin Antenna On-body for Three Diversity Techniques at 2.4 Ghz". figshare. <https://hdl.handle.net/2134/17585>.

Human effect on Twin Antenna On-body for Three Diversity Techniques at 2.4 GHz

D. Al-Saffar¹, R. M. Edwards¹, O. Ojerinde¹, C. J. Panagamuwa¹ and R. D. Seager¹

¹ Center for Mobile Communication Research, Loughborough University, UK, r.m.edwards@lboro.ac.uk

Abstract—Since the user is generally in the near field On-body antennas are accepted as more complex to optimise than their free space counterparts. Use of the body as a platform for wearable electronics is a topical subject. Omnidirectional antennas are thought to be useful for antennas in body area networks. However, the desirable properties of omnidirectional radiation patterns close to humans are severely diminished due to the lossy load nature of biological matter and high levels of scattering due to shadowing and mismatch. To alleviate these problems two or more antennas can be used on the body. In this paper, two on body antennas are used with three different combination techniques in order to evaluate the diversity performance and then compared with their free space equivalents. Three diversity techniques are used – Selective, Maximal Ratio and Equal Gain.

The frequency of operation was 2.4GHz.

Index Terms—*on-body channels, SIMO, Body Area Networks, SC, EGC, MRC.*

I. INTRODUCTION

Omnidirectional antennas are a desirable type of on-body transducer. However, antennas close to the body suffer severe perturbations to their characteristics such as quality factor, efficiency and resonant frequency. These perturbations are caused by reflections from skin, absorption of energy in matter and reactive coupling of the antenna and the body via the electromagnetic fields generated by radiating elements. The body appears as a close lossy load to any body mounted antenna system [1]. This loading and loss destroys any pattern symmetry for on-body antennas.

A partial solution is to have multiple antennas on the body allowing better omnidirectional field strength due to the superposition of element patterns. Nevertheless, as humans move, the propagation paths from all or any antennas can still be blocked by limbs [2]. Therefore deep fades due to obstruction are more likely for antennas worn close to the body. It is less likely however that two will be blocked at the same time. The use of more than one antenna allows the use of diversity techniques. This paper considers on and off-body twin antenna diversity techniques[3][4] and concludes to whether or combining techniques are useful for inter-body communications. Three environments were measured, an office, a laboratory and a corridor. Two positions for the receive antennas are considered, at the shoulder and at the waist. These results concern receive diversity.

Selective combining is a simple diversity technique. In this technique, the strongest signal from the diversity branch is selected at the receiver. The more branches the lower the

probability of a deep fade and the higher the probability of a better signal at the receiver [5] [6]. Maximal Ratio Combining (MRC) obtains the weight that maximizes the output Signal to Noise Ratio (SNR), that is, it is optimal in terms of SNR. In Equal Gain Combining (EGC) all of the weights have the same magnitude, but a phase opposite to that of the signal in the respective branch [7]. Since the electronic concerned with implementing each technique are different it is worth considering all three. In this work, a two-branch diversity system will be considered.

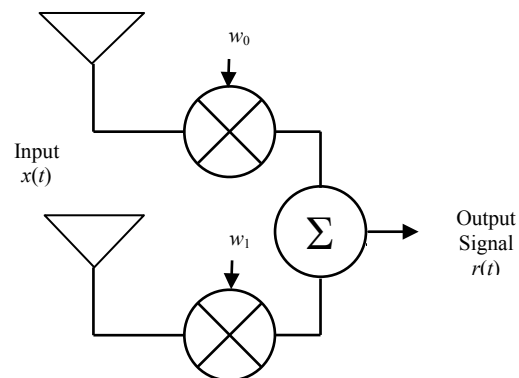

Fig. 1 Two-antenna receiver model for selection combining used in equation 9.

II. ANALYSIS FOR DIVERSITY

In [6] to allow the comparison of our results against a bench mark an analytical form of selection combining has already been discussed. In this paper an MRC analytical form will be used to provide a benchmark performance for a diversity system. The model used is $N=2$ version of the general treatment given in [7]. The diagram in Fig. 1 shows the weighting of the branches before combination. This model assumes that each sample is an independent sample of the fading process and that the fading process is slow, flat and Rayleigh in nature. This method will be used to illustrate the baseline expectation for a two antenna SIMO system using MRC.

Over one period T_s the power in the signal for any single path is given by:

$$\begin{aligned}
 p &= \frac{1}{T_s} \int_0^{T_s} |h_n(t)|^2 |u(t)|^2 dt \\
 &= |h_n(t)|^2 \frac{1}{T_s} \int_0^{T_s} |u(t)|^2 dt = |h_n|^2
 \end{aligned} \tag{1}$$

Where $h_n(t)$ represents the channel and $u(t)$ the unit power signal transmitted.

The simplification of (1) is achieved by assuming to $|h_n(t)|$ to be constant over the period T_s and $u(t)$ to have unit power. Letting $E\{|n_n(t)|^2\} = \sigma^2$ where E is time averaging operator and σ^2 is the variance, the instantaneous SNR for any path can be written as:

$$\gamma_n = \frac{|h_n|^2}{\sigma^2} \quad (2)$$

For Rayleigh fading the path $h_n = |h_n| e^{j\angle h_n}$ in which $\angle h_n$ has a uniform distribution over 0 to 2π and $|h_n|$ has a Raleigh fading probability density function.

$$|h_n| \approx \frac{2|h_n|}{P_0} e^{-|h_n|^2/P_0} \quad (3)$$

$$\gamma_n \approx \frac{1}{\Gamma} e^{-\gamma_n/\Gamma} \quad (4)$$

$$\Gamma = E\{\gamma_n\} = \frac{P_0}{\sigma^2} \quad (5)$$

Where Γ is the average SNR of a single element and P_0 is the statistical average of $|h(n)|^2/2$ [3][5].

MRC obtains the weights that maximise the output SNR. Therefore with reference to Fig. 1 by writing the received signal at the array elements as a vector $x(t)$, and the output signal as $r(t)$ [5][7]

$$x(t) = h(t)u(t) + n(t) \quad (6)$$

$$h = [h_0, h_1, \dots, h_{N-1}]^T, \quad (7)$$

$$n = [n_0, n_1, \dots, n_{N-1}]^T \quad (8)$$

$$r(t) = w^H x = w^H h u(t) + w^H n \quad (9)$$

By using Cauchy–Shwarz inequality, this maximum when w is linearly proportional to h , that is

$$w = h \quad (10)$$

$$y = \sum_{n=0}^{N-1} \gamma_n \quad (11)$$

$$P_{out} = 1 - e^{-\frac{y_s}{\Gamma}} \sum_{n=0}^{N-1} \left(\frac{y_s}{\Gamma}\right)^n \frac{1}{n!} \quad (12)$$

The output SNR is, therefore, the sum of the SNR at each element.

For conciseness the results of [3] are not repeated here. However for a reliability of 99% (chosen arbitrarily), we use those results as a benchmark concluding that for two antennas with mutual coupling not worse than 0.7 in free space the gains for SC, MRC and EG are 15dB, 18dB and 17dB respectively.

III. PROCEDURE FOR MEASUREMENTS

The antenna sets constructed for the on-body measurement consisted of two identical quarter-wavelength monopole antennas on an isolated circular ground plane. The circular ground plane minimized unwanted surface corner reflections due to a finite ground plane size. Isolation was achieved using a ROHACELL disk that lifted the antenna a repeatable distance off the skin above the clothing by a distance of approximately 1cm. The antennas were designed and built to resonate at 2.4GHz. Comparisons on and off the body showed little variation in S_{11} . An antenna with its ROHACELL radome is shown in Fig. 2.

The (Rx) antennas were connected to a Serial Data Analyzer (LeCroy SDA 18000) using 3m long RG316 cables. Channels 1 and 2 were set to respond to a maximum frequency of 6GHz. The sampling rate was as 500kS/s. An adjustable rig was constructed to allow the antennas to be positioned at shoulder and waist height in a repeatable fashion. The experiment was carried out at 2.4GHz. An HP 8350 signal generator set to 10.5dBm was used to transmit power to a horn antenna (Tx). With the horn antenna radiating, the SDA is set to measure the received power in the two-monopole antennas attached to channel 1 and channel 2 simultaneously.

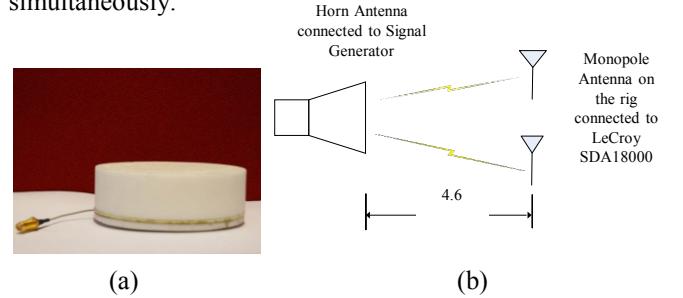

Fig. 2. (a) Quarter wave monopole on a circular groundplane, (b) Schematic of the transmitting and receiving antennas.

Note that the horn antenna main beam is approximately in the null of the patterns for the received monopoles, which would be the worst case for the LOS measurements. Since the horn and antennas were not in the near field it is reasonable to assume that it was the scattered component of the wave that was being measured. These measurements are for static humans and shadowing was not considered.

The measured data was then post processed in Matlab. Fig. 3 shows a volunteer with 2 antennas in place. The photo shows the shoulder configuration. The range between the transmitter and receivers was 4.6m for all experiments. The measurements took place in three locations. The communications laboratory (LAB), the corridor and the Centre for Mobile Communications Research (CMCR). The width of the lab is 7.16 m while the length was 8.31 m, the distance between floor and ceiling is approximately 3m. Contents are assorted office furniture. Open ended corridor length and widths were 30.8m and 2.2m respectively and the same distance between floor and ceiling as in the lab environment. The corridor was empty. The office width was 5.1m has a length was 15.2m ceiling with a height of 3m

approximately. Its contents were of assorted tables and four-side desks.

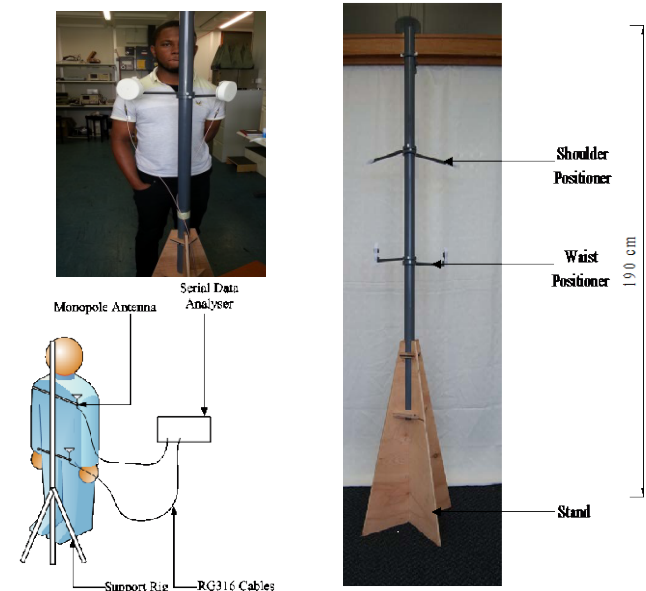

Fig. 3. Top left: Procedure for an on-body measurement; Bottom Left: Cable arrangements; Right.: Plastic Experimental rig.

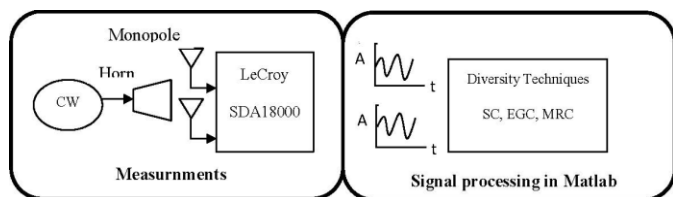

Fig. 4. System diagram for Diversity combining Techniques measurement and analysis.

The system diagram is shown in Fig. 4. In our research we first looked at 300 seconds worth of data for self similarity and found that subsets of 6 seconds were adequate to reproduce the mean and variance. Measurements were therefore taken for two scenarios, one with the antennas on a human and one without. Every care was taken to make sure the antennas were in the same place relative to the environment but also that the antennas were as close to the surface of the volunteer when in place. The antenna stand was made of non-conducting plastic and was present in both on and off the body measurements. Any effect therefore is present in all results.

Each measurement was taken for 300 seconds giving 15,000 power points in each channel. All other elements with the experiment were unchanged and therefore it is reasonable to assume that any improvement or worsening of diversity result in terms of average received power is due to human effect. The two receive antennas were 50cm apart, which were approximately 4 wavelengths at 2.4GHz. Fig. 3 shows the experimental rig and the connections to the data analyzer. Care was also taken to ensure the polarity of the antennas and antenna cabling was consistent on and off the body and that symmetry was maintained.

Cable chokes were not used in our experiments, however the match for our antennas both on and off the body was very

similar and we therefore feel it reasonable to assume that the effects of cable on the received signal were minimal.

IV. RESULTS

The paths and scenarios measured are shown in Table 1. All on-body measurements were duplicated off body in all three test environments. The combination antenna positions were shoulders and waist.

TABLE I. RESULTS FOR ON AND OFF BODY CHANNELS. RESULTS IN TABLE 1 ARE IN dBm ROUNDED TO 1 DECIMAL PLACE. SC=SELECTIVE COMBINING, EGC=EQUAL GAIN COMBINING AND MRC =MAXIMAL RATIO COMBINING.

	<i>Right ON</i>	<i>Right Off</i>	<i>Left ON</i>	<i>Left Off</i>	<i>SC On</i>	<i>SC Off</i>	<i>EGC On</i>	<i>EGC Off</i>	<i>MRC On</i>	<i>MRC Off</i>
Waist										
Lab	-51.3	-55.9	-51.4	-61.6	-48.2	-52.8	-45.2	-52.3	-45.0	-51.5
Office	-57.2	-64.8	-61.5	-68.3	-51.8	-55.1	-51.1	-55.3	-50.5	-54.5
Corridor	-59.0	-72.3	-42.7	-41.6	-42.7	-41.3	-41.5	-40.3	-41.0	-40.0
Shoulder										
Lab	-49.0	-60.8	-58.5	-64.4	-48.4	-55.1	-47.3	-55.1	-46.6	-54.4
Office	-66.9	-66.9	-58.5	-67.2	-53.9	-56.0	-53.0	-56.1	-52.3	-55.3
Corridor	-62.0	-47.9	-62.0	-46.5	-51.3	-44.2	-51.4	-41.2	-50.4	-40.9

Three representative sets of results are shown in Fig. 5, 6 and 7. The figures show SC, EGC and MRC for on and off body scenarios. To obtain the gain values results of the received signal strength samples were post processed using Matlab.

TABLE II. RESULTS FOR COMBINING TECHNIQUES GAINS.

	<i>SC Gain On</i>	<i>SC Gain Off</i>	<i>EGC Gain ON</i>	<i>EGC Gain Off</i>	<i>MRC Gain On</i>	<i>MRC Gain Off</i>
Waist						
Lab	3.1	3.1	6.1	3.8	6.3	4.4
Office	5.4	9.7	6.1	9.5	6.7	10.3
Corridor	0	0.3	1.2	1.3	1.6	1.6
Shoulder						
Lab	0.6	5.7	1.7	5.7	2.4	6.4
Office	4.6	10.9	5.5	10.8	6.2	11.6
Corridor	10.7	2.3	11.4	5.3	11.6	5.6

With reference Fig 5, the results for waist placed antennas in a Lab are presented. The data for these channels is in Table 2, The antennas are at the midpoint of the body. The Lab should be considered as a rich scattering environment. The MRC and EGC gains of on-body almost the same which improved by 2 dB and 3dB respectively on off- body. In Fig. 6 Selection, Maximal ratio and Equal gain combining results for on and off shoulders antennas were taken in the office. The results show that on-body SC is better than off-body SC by approximately 2 dB but on-body MRC is better than off- body MRC by 3 dB. Referring to Table 2, we see that when referenced to the best channel mean at CDF 99% reliability with MRC and EGC gain improved off-body by almost 11 dB and on-body by 6 dB. This compares to the 18dB possible predicted by the Rayleigh fading analysis

which is discussed in [3], [7]. This measurement set took place in an office. Using the rig shown in Fig. 3 an antenna was positioned on each shoulder of a volunteer and the left and right branches were measured. The left and right off-body branches were then measured again without the volunteer. Also the office is a rich scattering environment. The Rx power is similar for three channels and approximately 8dB better for the left on body channel.

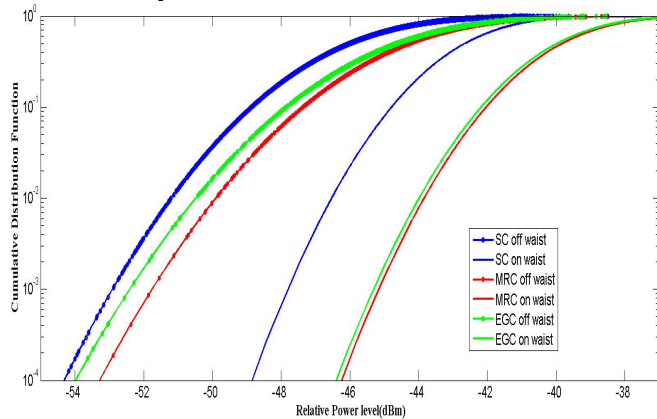

Fig. 5. Selection, Maximal Ratio and Equal gain combining gain results for on and off the waist in a laboratory.

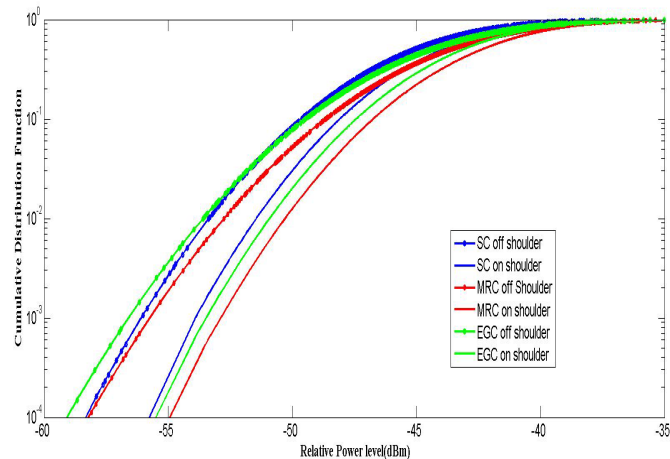

Fig. 6. Selection, Maximal Ratio and Equal gain combining gain results for on and off the shoulder antennas in an office.

Lastly in Fig. 7 the results for SC, MRC and EGC on and off the body, for antennas on the shoulders are shown for a corridor environment. The antennas are high off the ground. The corridor should be considered a poor scattering environment.

By referring to Table 1, for the channel data. In this environment the two sets of branches are roughly similar to one another but approximately 18dBs worse for the on-body system. The best set of branches was seen to be the off-body combination. From Table 1 and Table 2, the general channel conditions for the on-body branches were better. Only one corridor environment with shoulder positioned antennas had a better off body figure in terms of overall performance.

For MRC gain the off-body branch combination was generally either equal or better than the on-body branch combination. Overall the on-body MRC provides the best branch combination.

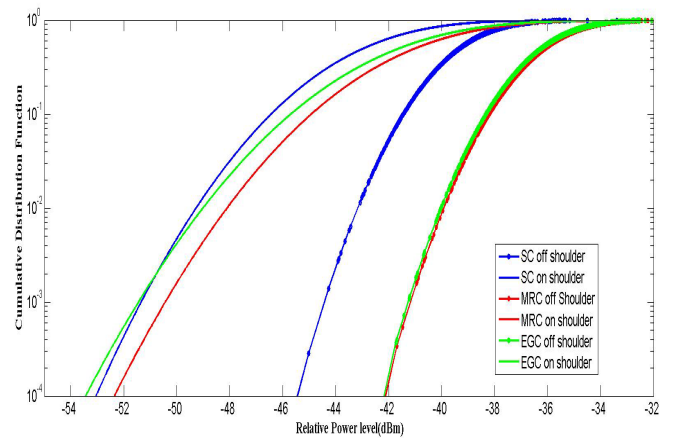

Fig. 7. Selection, Maximal Ratio and Equal gain combining gain results for on and off the shoulder in a corridor.

V. CONCLUSIONS

In this paper, we have used three diversity combining techniques to extend a technique to aid the understanding of how a human volunteer changes the channel for body worn single input multiple antenna output systems. Two receive antennas were considered here, but the technique and analysis are applicable to experiments for more than two antennas. It has been seen that despite the complex fading environments studied general trends can be identified.

Overall MRC was always beneficial and at 2.4GHz in these common environments can provide significant gain over the selective combining and EGC. However, SC may be simpler and perhaps cheaper to implement due to reduced complexity in manufacture.

REFERENCES

- [1] R. M. Edwards, "Wireless Body Area Network Channels," in *LTE-Advanced and Next Generation Wireless Networks: Channel Modelling and Propagation*, vol. 2012, John Wiley & Sons, 2012, p. 568.
- [2] S. L. Cotton and W. G. Scanlon, "Channel Characterization for Single and Multiple-Antenna Wearable Systems Used for Indoor Body-to-Body Communications," *IEEE Trans. Antennas Propag.*, vol. 57, no. 4, pp. 980–990, Apr. 2009.
- [3] R. Janaswamy, *Radiowave Propagation and Smart Antennas for Wireless Communications*, vol. 599. Boston: Kluwer Academic Publishers, 2002, ch. 7, sec. 3, pp. 189–203.
- [4] I. Khan, P. S. Hall, A. A. Serra, A. R. Guraliuc, and P. Nepa, "Diversity Performance Analysis for On-Body Communication Channels at 2.45 GHz," *IEEE Trans. Antennas Propag.*, vol. 57, pp. 956–963, 2009.
- [5] Abbasi, Q. H., M. M. Khan, S. Liaqat, M. Kamran, A. Alomainy, and Y. Hao, "Experimental Investigation Of Ultra Wide-Band Diversity Techniques For On-Body Radio Communications" *Progress In Electromagnetics Research C*, Vol. 34, 165–181, 2013.
- [6] D. Al-Saffar, E. Habbab, R.M. Edwards and O. Ojerinde, "Human effect on On-body Selective Combining at 2.4GHz" *Loughborough Antennas & Propagation Conference (LAPC)*, 2014
- [7] R. K. Mallik, M. Z. Win, J. W. Shao, M. S. Alouini, and A. J. Goldsmith, "Channel capacity of adaptive transmission with maximal ratio combining in correlated Rayleigh fading," *IEEE Trans. Wirel. Commun.*, vol. 3, pp. 1124–1133, 2004.