

Intelligent Railway Cross Level Gates and Signaling System using Fuzzy Logic Control Technique

¹Olaniyi* O. M., ²Abdullahi, I. M., ³Maliki, D., ⁴Lasore T.M.

¹²³⁴Department of Computer Engineering

Federal University of Technology, Minna, Niger State Nigeria

[*mikail.olaniyi@futminna.edu.ng](mailto:mikail.olaniyi@futminna.edu.ng), amibrahim@futminna.edu.ng, maliki.danlami@futminna.edu.ng,
oluwatosin1234@gmail.com

Abstract— Current manually operated gates at the railway cross levels of developing countries are stressful and time wasting. This has exposed pedestrians to high rate of accident resulting to loss of lives and drastic reduction of the country's economy. Different systems have been developed to prevent rail accidents at the level crossing but they are not effective and in most cases are too expensive to implement. This study presents a prototype model of an intelligent railway cross level gates and signaling system using Mamdani fuzzy logic control technique. The intelligent system has the ability to detect the arrival/departure of a train and close/open the cross level gates respectively. The system response was evaluated with respect to time. The results after the evaluation of the developed system showed that the system with fuzzy intelligent control technique has a high response with respect to time compared to a system without an intelligent technique. The large scale implementation of the developed intelligent railway cross-level gate and signaling system can be used to prevent avoidable accident occurrence at the level crossings and thus, reduces loss of lives as well as improvement of the nation's economy through efficient delivery of goods and services in Africa.

Keywords — *Signaling System, Cross levels Gates, Fuzzy Logic, Railway, and Intelligence.*

I. INTRODUCTION

Transportation is the movement of people, good and services from one geographical location to another. Different modes of transportation include air, land and water. Transportation enables trade between persons and this is essential for the development of civilization [1]. Since road transportation system could not ascertain safety and its accident could not be accurately prevented, the railway transportation system is the most suitable and cheapest mode of transportation for heavy traffic flows with its greatest carrying capacity in overland transport modes and freight movement within different parts of the country [2].

In Nigeria, over eighty percent of rail accident occurs on railway crossings [3]. In the light of this, the high rate at which derailment occur at the railway cross levels had caused loss of lives, goods, services which had degraded the Nigeria's economy [4]. Common manually operated gates in Nigeria at cross levels include: Okuku-Oshogbo, Iddo-Apapa, Agbado-Ijoko, Agege and Ikeja, Lagos State, Nigeria. This operational method has a lot of bottlenecks including stress and energy

consumption on the attached workforce and high cost of manpower management involved for opening and closing of such cross level gates.

An intelligent system capable of emulating these properties of imprecision and vagueness in some aspects of human intelligence at cross level gates could be adapted to effectively monitor and control railway cross level gate and signalling signs for pedestrians. This technological development will provide preventive measures for motorists, and pedestrians against train-motorists and train-pedestrians accident especially at the cross levels. In rail network, signalling is globally seen as the backbone to safety and efficiency.

In this paper, the concept of Fuzzy Logic Controller designs in Fuzzy expert system development is used to develop an intelligent prototype model of cross level gates and signaling systems for effective management of motorist and pedestrians at railway cross levels. The develop model is capable of controlling motorists and pedestrians passage at cross levels through prior alerts, audible warning sound and closure of gates. The large scale adaptation of the developed intelligent railway cross-level gate and signaling system at developing countries railway is expected to prevent avoidable accident occurrence at the level crossings and thus, reduces loss of lives as well as improvement of the nation's economy through efficient delivery of goods and services.

The remaining section of the paper is organized into: Section 2 provides review of related works; Section 3 gives system mathematical modelling; Section 4 presents System design and development Methodology; Section 5 gives the Results; Section 6 Conclusion and scope for future improvements.

II. RELATED WORKS

A number of related works have been reported in the development of railway cross level gates for the prevention of accident at the level crossing thereby enabling safety of lives and property.

In the approach of [5], load cells were used as pressure sensors to detect the arrival of the incoming trains through the exertion of trains on the load cells. This process was used control the operation of cross level gates. The approach enjoyed fair efficiency and ease of implementation. The

limitation of this work lies in its cost of implementation. Also, load cells are highly affected by environmental condition like temperature.

Similar Field Programmable Grid Array (FPGA) based System on Chip (SoC) was developed in [6]. In this work, FPGA-SoC was used to prevent accident on railway cross levels. The system uses two Radio Frequency (RF) transceivers for communication between the incoming train and the cross levels. The SoC was used to prevent accident at the cross levels based on the communication of the two RF transmitters. The system enjoyed better wireless data communication to avert possible railway cross level accident. The developed system of [6] was, however, expensive to implement. Besides, obstruction of Fresnel Zone could result in accident in the system design. The design consideration in [6] attempt was not resource friendly. Only five out of four hundred and seventy five pin was used for system development. RF transceiver can be affected by other Signal generating devices and thus, lead to fatal accident at cross levels.

In [7], a microcontroller based railway gate and crossing control system based on magnetic sensors was developed. The magnetic sensors were used to detect the trains to control the operation of the cross level gates. The system was capable of reducing high level of human involvement at cross levels. The system is, however, flattered by high power consumption and very high delay in the process of cross level gate closure. This much longer delay could lead to unnecessary road traffic at the cross levels. Also in [8], Programmable Logic controller for automatic level crossing that uses sensors to detect the arrival and departure of trains and use of many devices to control the operation of the gates was developed. Flexibility and efficient operation are the strength of this work. The system suffers from design complexity which could lead fatal and unexpected accident at the crossing levels. It is not economical because it is too expensive to implement.

Similar system developed around vibration sensors in obstacle detection in railway network was developed in [9]. The vibration sensors are used to detect the arrival of trains and signals are sent to Infrared sensor so that the gates at the cross levels are operated based on the received signals. This work enjoyed good performance, human involvement and errors reduction. High-level human expertise is needed in the mounting orientation of the vibration sensors.

Also authors in [10] developed an automatic railway gate control system using a microcontroller. This system uses inductive sensors to detect the arrival of trains to control the operation of the gates at the cross levels. The strength of this system lies in low power consumption and its efficient operation. However, the system cannot detect obstacles and thus could lead to high rate of accident at the level crossings. The system design proposition is time wasting at cross levels which could lead to high traffic congestion at the cross levels.

In this paper, we improved on these baseline related works by developing intelligent system capable of detecting the arrival/departure of a train on the rail track to control the operation of the cross level gates using Mamdami Fuzzy logic control technique. Fuzzy Logic addresses the ambiguity in human thinking in perceptions and interpretations by its ability to mimic human reasoning using a small number of rules and

still produces a smooth output. The developed system has the capacity to reduce high human involvement, errors, time wasting and unnecessary traffic congestion at the level crossings. It is very easy to implement and prevent accident at the cross levels thereby ensuring safety of lives and property as well as efficient delivery of goods and services for the improvement of the country's economy.

III. SYSTEM MATHEMATICAL MODEL

The main focus of this study is effective control of accidents through closure and opening of gates at the level crossing by the use of DC motors. The Fuzzy Logic Control of this control environment is shown in Figure 1.

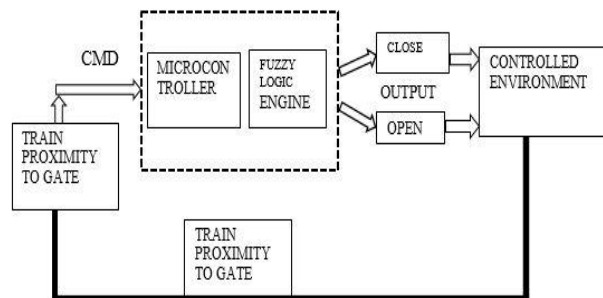

Fig.1. Fuzzy logic control environment

Where:

CMD = Targeted train proximity

Train proximity to gate = Feedback from sensor in the controlled environment

Output = Close, Open

Fig.1. Fuzzy Logic Controller for the Intelligent System

From Figure 1, the behavior of DC motor output was modelled and used to evaluate the system response in gate control. The motor consists of the armature, inductor powered by applied voltage (V_a). Torque, back e.m.f. and armature current are generated when the motor is powered by the applied voltage. The mathematical modelling of both electrical and mechanical system of Figure 2 is as follows:

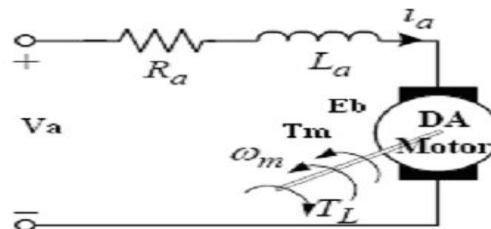

Fig. 2. Modelling diagram of gate control of the intelligent Railway system

For the Electrical System

$$V_a(t) = R_a i_a(t) + L_a \frac{di_a(t)}{dt} + E_b(t)$$

$$Va(s) = RaIa(s) + LaSIa(s) + Eb(s) \quad (1)$$

$$Tm(s) = K_t ia(t)$$

$$Tm(s) = K_t Ia(s)$$

$$Ia(s) = \frac{Tm(s)}{K_t}$$

For the Mechanical System

Torque:

$$Tm(s) = (JmS^2 + BmS)\theta m(s) \quad (3)$$

Back e.m.f.:

$$Eb(t) = Kb \frac{\partial \theta m(t)}{\partial t}$$

$$Eb(s) = KbS\theta m(s) \quad (4)$$

From Equation (1)

$$Va(s) = RaIa(s) + LaSIa(s) + Eb(s)$$

Substitute Equation (2) into Equation (1)

$$Va(s) = Ra \frac{Tm(s)}{K_t} + LaS \frac{Tm(s)}{K_t} + Eb(s)$$

$$Va(s) = \frac{RaTm(s) + LaSTm(s)}{K_t} + Eb(s)$$

$$Va(s) = \frac{Tm(s)[Ra + LaS]}{K_t} + Eb(s) \quad (5)$$

Substituting Equation (3) into Equation (5)

$$Va(s) = \frac{(JmS^2 + BmS)(Ra + LaS)\theta m(s)}{K_t} + Eb(s) \quad (6)$$

Removing back e.m.f $Eb(s)$

Substituting Equation (4) into Equation (6)

$$Va(s) = \frac{(JmS^2 + BmS)(Ra + LaS)\theta m(s)}{K_t} + KbS\theta m(s)$$

$$Va(s) = \frac{(Ra + LaS)(JmS^2 + BmS)\theta m(s)}{K_t} + KbS\theta m(s)$$

$$Va(s) = \frac{(Ra + LaS)(JmS + Bm)S\theta m(s)}{K_t} + KbS\theta m(s)$$

Factorising out $S\theta m(s)$

$$Va(s) = S\theta m(s) \left(\frac{(Ra + LaS)(JmS + Bm)}{K_t} + Kb \right)$$

$$G(s) = T.F. = \frac{Output}{Input} = \frac{\theta m(s)}{Va(s)}$$

$$G(s) = \frac{1}{S \left(\frac{(Ra + LaS)(JmS + Bm)}{K_t} + Kb \right)}$$

$$G(s) = \frac{1}{S \left(\frac{(Ra + LaS)(JmS + Bm) + K_t K_b}{K_t} \right)}$$

$$G(s) = \frac{K_t}{S((Ra + LaS)(JmS + Bm)) + K_t K_b}$$

Where:

Ra = Armature resistance

La = Armature Inductance

Jm = Motor inertia

K_b = Back e.m.f constant

G_s = Transfer function

I_a = Armature current

V_a = Applied Voltage

Tm_s = Motor Torque

K_t = Torque Constant

The following values were obtained based on the proposed DC motor to be used for the intelligent system.

TABLE 1: SOME PARAMETERS VLAUES

Parameter	Value
Kt	2NM/Amp
Kb	1 V/rad/sec
B	16.25 MN/rad sec
J	4 Kg/m2
Ra	0.35Ω
L	0.4H

Substituting the following values into the transfer function:

We have:

$$G(S) = \frac{2}{2S^3 + 7S^2 + 6S + 2} \quad (6)$$

IV SYSTEM DESIGN AND DEVELOPMENT

The intelligent prototype of cross level gates and signaling systems was developed around Mamdani's Fuzzy Inference system modelled and simulated in MATLAB 2013a. The system with Mamdani Fuzzy Logic Controller gave high response with respect to time compared to a system without an intelligent technique. This significantly improves the performance of the system because intelligent techniques are important tools for decision making. Arduino IDE software was used for the programming of the Atmega2560 microcontroller chip, the fuzzy engine, which aids the effectiveness and efficient control of the entire working of the system

A. Hardware Subsystem Development Considerations

The hardware subsystem consists of five different units namely: Power Supply Unit, Gate Control Unit (Servo motors), Signaling Unit in Liquid crystal Display (LCD),

Lighting system in Light Emitting Diode {LED}, Buzzer), Fuzzy Control Unit (ATMEGA 2560) and the Sensing Unit using Passive Infra-red (PIR)). Figure 3 describes overall system block diagram.

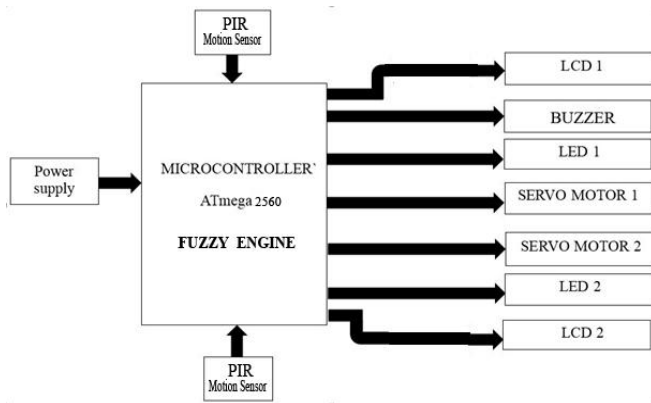

Fig.3. Overall System Block Diagram

In developed system, the Passive Infrared Sensors detect both the arrival and departure of a train and sends a signal to the Atmega2560 microcontroller which enables the Buzzers, LCD and LED's to display safety control measures to all road users and the Servo Motor to open or close the gates at the railway level crossing. Figure 4 shows the inter-operability of each electronic device in the overall circuit diagram of the developed system.

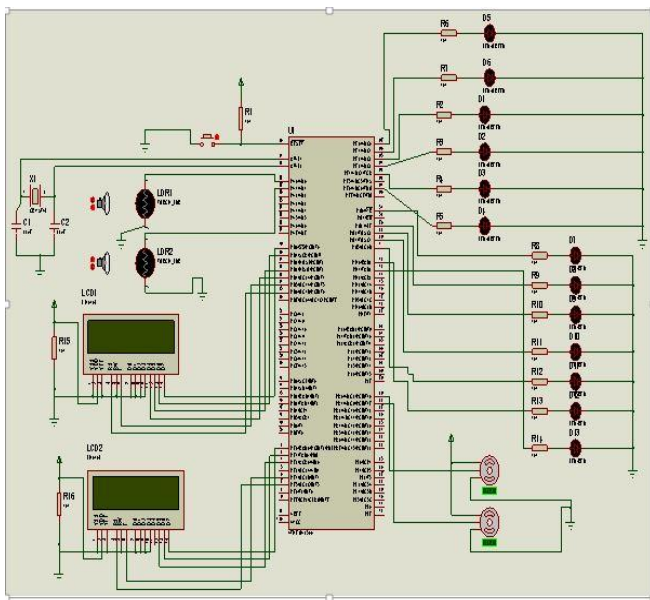

Fig. 4: System Circuit Diagram

B. Software Design consideration: Fuzzy Logic Controller Design

For the design of controller for the intelligent railway cross level gates and signaling system, input and output variables that affect the operation of the cross level gate were

taken into consideration. These input and output variables were further defined by means of membership functions. The input variables are speed and distance while the output variable is the gate control. The five stages of Mandami's Fuzzy inference system in Fuzzification, Fuzzy rules combination, consequence, aggregation of output and defuzzification were modelled in MATLAB 2013a Fuzzy Logic Toolbox. The speed input variable was fuzzified from crisp input into linguistic variable of Low, Average and High. Usually the speed of Railway is from zero to sixty five kilometer to cross level. This universe of discourse (0-65km) was used to assign linguistic values to fuzzified linguistic speed variables as follows: Low (10.75 0), Average (10.75 32.5) and High(11.04 65) using Gaussian Membership function as shown in Figure 5.

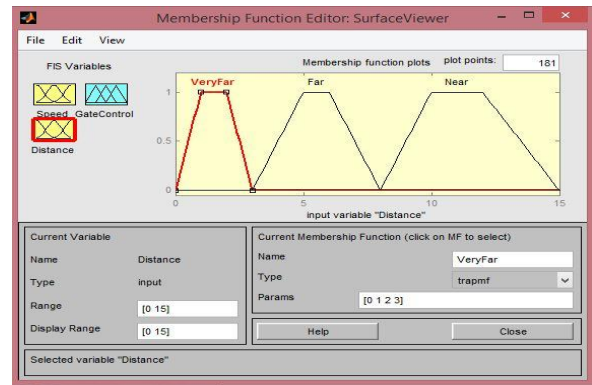

Fig.5. Speed Membership Function

Consequently, the distance (PIR Sensor Sensing distance) input variable was fuzzified from crisp input into linguistic variable of Very far, Far and Near. Usually the distance of Railway is from zero to fifteen meter to Cross level. This universe of discourse (0-15m) was used to assign linguistic values to fuzzified linguistic distance variables as follows: Very far (0 1 2 3), Far (3 5 6 8) and Near (8 10 12 15) using Triangular Membership function as shown in Figure 6.

Also, the output (Cross Leve Gate opening/closure) variable was fuzzified from crisp input into linguistic variable of Fast, Moderate and Slow. Usually the optimum time to open and close the Railway gate at cross level is from zero to twelve seconds. This universe of discourse (0-12s) was used to assign linguistic values to fuzzified linguistic distance variables as follows: Fast (0 2 4), Moderate (4 6 8) and Slow (8 10 12) using Triangular Membership function as shown in Figure 7.

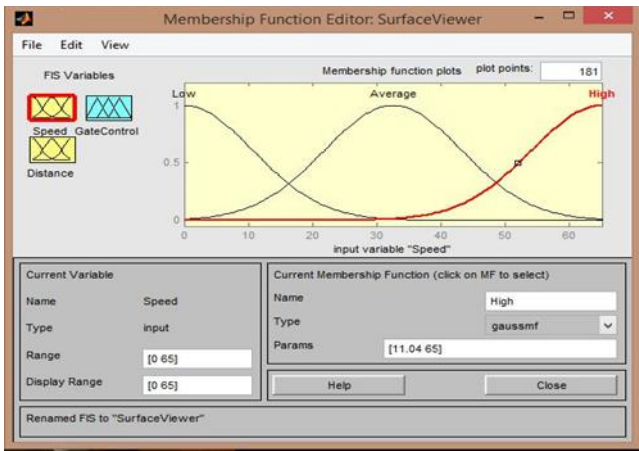

Fig. 6. Distance Membership Function

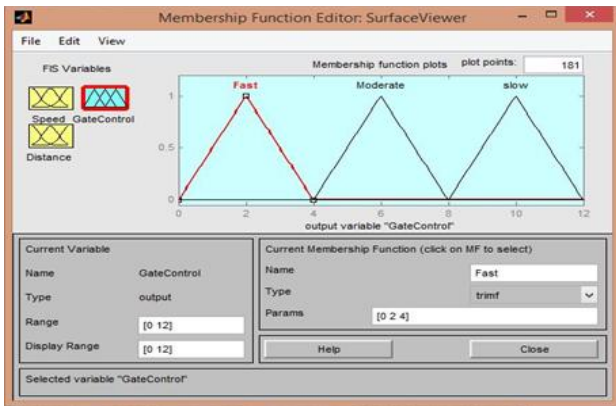

Fig.7. Gate Control Membership Function

The fuzzy rule for the intelligent system was modelled based on these fuzzified input and output variables using IF and Then statement related in Table 2.

Table 2: Railway cross level and signaling system linguistic rules

Rule No	Rule statement
Rule 1	If the Speed is low and the distance is very far, gate operation is slow
Rule 2	If the Speed is average and the distance is very far, gate operation is slow
Rule 3	If the Speed is high and the distance is very far, gate operation is fast
Rule 4	If the Speed is low and the distance is far, gate operation is slow
Rule 5	If the Speed is average and the distance is far, gate operation is moderate
Rule 6	If the Speed is high and the distance is far, gate operation is fast

Rule 7	If the Speed is low and the distance is near, gate operation is fast
Rule 8	If the Speed is average and the distance is near, gate operation is fast
Rule 9	If the Speed is high and the distance is near, gate operation is fast.

Using the rule editor in Figure 8, the linguistic rules

in Table 2 was used to map input space to output space to control the entire system. The rule editor determines the overall operation of the system. The Linguistic rule consists of two antecedent block (IF and THEN) and these two is joined with the “AND” statement.

The execution of the rule that fires a specific output was designed in a way to match the desired output. The rules used are based on the fuzzified input of the speed and distance and their range. Consequently, a 3x3 matrix of nine rules was developed and these inputs were capable of giving desired output of the system as shown in Figure 10. The output is the probability that the gate control will be (S) slow, Speed, (M) moderate and (F) fast.

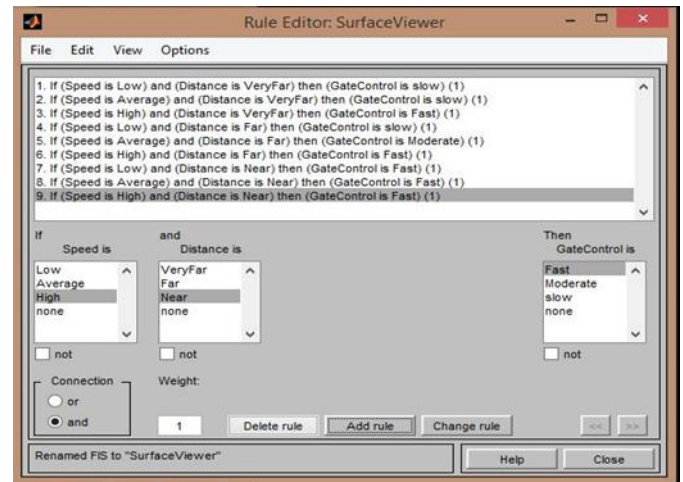

Fig. 9. Rule Structure using MATLAB fuzzy rule editor

		Speed		
		L	A	H
Distance	V.F	1 S	2 S	3 M
	F	4 S	5 F	6 F
	N	7 F	8 F	9 F

Figure 10: Fuzzy Rule Matrix of the Intelligent System

There is an evident equilibrium to the matrix after the conclusion had been transferred from the nine rules to the matrix. The column side represents the speed while the row side represents the distance. The system flow chat is represented by Figure 11. The system is always in the “Safe Mode”, when a train is detected “Unsafe Mode” it triggers the gates to close. The system returns back to “Safe Mode” at the departure of the train.

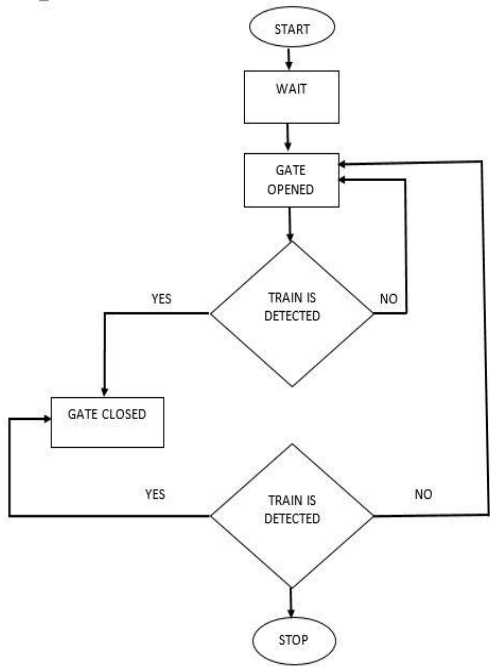

Fig.. 11. The intelligent Railway System Flowchart

Figure 12 shows the Simulink representation of the intelligent system fuzzy logic controller design in sections 4.3 with the transfer function of the developed mathematical modelling of controlling motors in equation 6.. The result of the system response with and without Fuzzy logic Controller is reported in section 5.

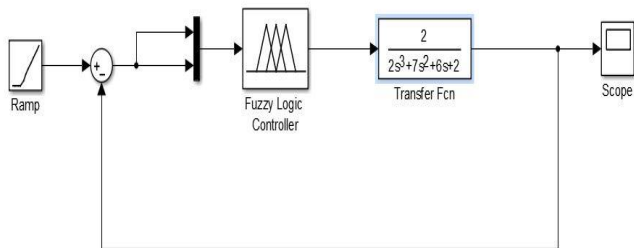

Fig.12.. Matlab Simulink Diagram for the investigation of System Response

V RESULTS AND DISCUSSIONS

Figure 13 shows the surface viewer, the result of the functionality of the developed system in terms of the relationship of the speed, distance and the gate control membership functions. On the surface viewer plot, X-axis represents speed, Y-axis represents Distance and the Z-axis

represents the Gate Control. The Fuzzy Logic Controller ensures that both membership Function and the rule matrix were carefully taken into consideration for the control of the gates at the railway cross levels.

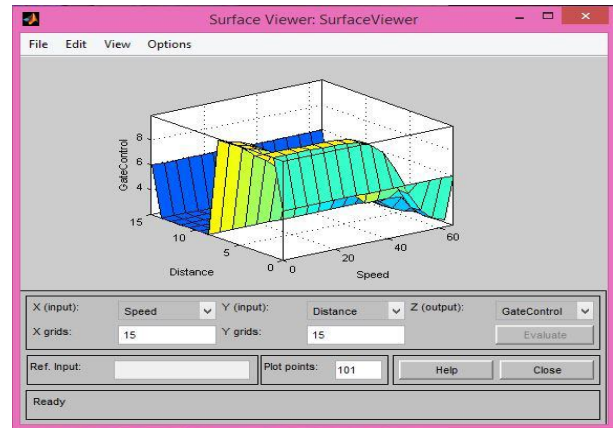

Fig.. 13. Surface Viewer of Input and Output Relationship

Considering Figure12, two different outputs were obtained to justify the use of fuzzy Logic control in evaluating the system response. First, system output response without the implementation of Fuzzy Logic Controller is represented by figure 14. Fuzzy Logic controller block in Figure 12 was removed. The absence of fuzzy logic controller within the system as shown in Figure 14 makes the performance of the system unstable

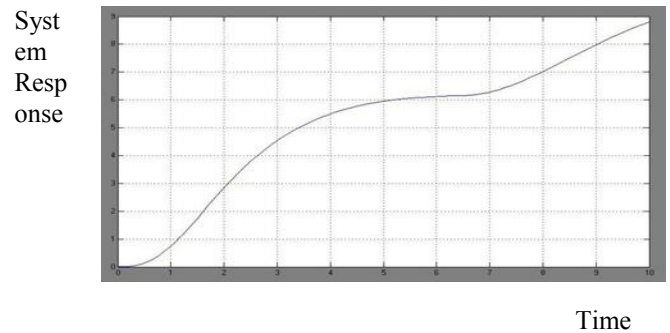

Fig. 14. System response without FL controller

However when the Fuzzy Logic controller was added to Figure 12, the system instability was reduced to the lowest minimum and better system performance was achieved as shown in Figure 15.

The overall prototype diagram of the developed intelligent Railway cross level gates and signaling systems is shown in Figure 16.

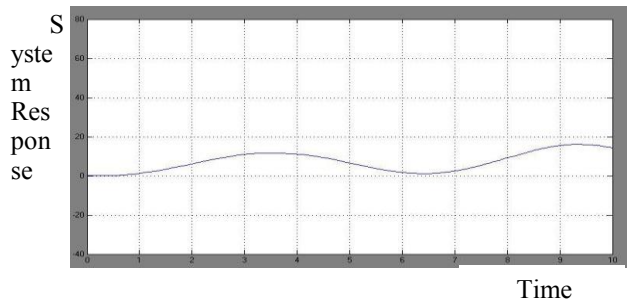

Fig. 15. System response with fuzzy logic controller



Fig. 16: Developed prototype of an Intelligent Railway Cross level gates and signalling System

VI. CONCLUSIONS AND SCOPE FOR FUTURE RESEARCH

In this paper, we have presented the design and development of prototype model of an intelligent railway cross level gate and signalling system using fuzzy logic control technique. The qualitative testing of the developed system showed that it is efficient in the prevention of accident at the cross levels. The developed prototype of the intelligent system is capable of detecting both the arrival and departure of a train and control automatically the operation of the railway cross level gates. Also, appropriate signage and audible measures were integrated to display and control road users at the level crossing thereby reducing high human involvement, time wastage and heavy traffic flow at the level crossings. The system's low cost of implementation and high response proved that the performance at various conditions is preferable when compared to existing systems. The large scale implementation of the developed intelligent railway cross-level gate and signaling system can be used to prevent avoidable accident

occurrence at the level crossings and thus, reduces loss of lives as well as improvement of the nation's economy through efficient delivery of goods and services in Africa.

The following scopes are suggested for future research endeavours:

1. Sensing design and development of the system could be investigated with an analogue accelerometer or a magnetometer for improved performance of the Intelligent Railway System.

2. Investigation of other artificial intelligent techniques such as Particle Swarm Optimization (PSO), Genetic Algorithm (GA) to evaluate the performance of different intelligent techniques and make recommendations based on the results obtained.

REFERENCES

- [1] D. A. Amba, A. Daniel, Danladi and Jonathan D. , An Appraisal of the Nigerian Transport Sector: Evidence from the Railway and Aviation Sub-Sectors, *Journal of Economics and Sustainable Development*, Vol. 4 No. 10, 2013, pp. 161-162.
- [2] E. K. Agbaeze and I. O. Onwuka, Boosting Railway System Infrastructure in Nigeria: The Public-Private Partnership Option, *Journal of Business Administration and Management Sciences Research*, Vol. 3, No 3, 2012, pp 039-048.
- [3] Rasheed, Railway Revival Raises Accident Rate. *The Punch*, Retrieved from <http://www.punchng.com>, March 8 2013.
- [4] O. Shoewu. And S. O. Olatinwo (2013), Design and Implementation of a Microcontroller Based Automatic Gate, *African Journal of Computing & ICT*, Vol. 6 No 1, 2013, pp 21-32
- [5] G. Kim, and K. Kang, Railway Gate Control System at Railroad-Highway Grade Crossing in Korea, A paper prepared presented at the 82nd Annual Meeting of the Transportation Research Board, Washington, August, paper No. A3A05-03- 3027, 2002
- [6] R. J. Ramachandran and J.P.Thomas, "FPGA Based SOC for Railway Level crossing Management System", *International Journal of Soft Computing and Engineering (IJSCE)*, Vol. 2 No 3, 2012. Pp 2231-2307
- [7] S.M.Ahmed S.M and Al-Zuhairi , Automatic Railway Gate and Crossing Control based Sensors and Microcontroller, *International Journal of Computer Trends and Technology (IJCTT)*, Vol. 4 , No 7, 2013, pp. 2134-2140
- [8] M. Kornaszewski. Programmable Logic Controllers for systems of automatic of the level crossing. *Advances in Electrical and Electronic Engineering* 5.1-2 2006: 143.
- [9] Ramasamy. N. , Automatic Obstacle Detection in Railway Network Using Embedded System", In *Proc. Of IRF International Conference ,Chennai, 2014, pp 93-95. Available online: http://iraj.in/up_proc/pdf/63-139773034493-95.pdf.*
- [10] N.Y. Hnin, M.T. Zaw and M.T. Hla, Automatic Railway Gate Control System Using Microcontroller, *International Journal of Science, Engineering and Technology Research (IJSETR)*, Vol. 3 No 5, 2014, pp 1547-1551.