

Design and Implementation of a Low Cost Digital Bus Passenger Counter

Adamu Murtala Zungeru^{1*}, Maidawa Kemba Deborah², Ambafi James Garba², Omokhafa James Tola²

1. School of Electrical and Electronics Engineering, University of Nottingham, Jalan Broga, 43500 Semenyih, Selangor Darul Ehsan, Malaysia.
2. Department of Electrical and Electronics Engineering, Federal University of Technology, Minna, Nigeria

* E-mail of the corresponding author: adamuzungeru@ieee.org

Abstract

Accountability is an important issue when buses are to be use for transport purposes. This research is principally aimed at the design and implementation of a simple and effective digital bus passenger counter. The work is mainly the design and construction of an electronics counter, counts the number of passengers going into or out of a bus or the number of cars going into or out of a gate. The set of methods and principles used in achieving the circuit are called the top-down methodology. The actual state of the entrance which coincides with the exit was noted. Two-switch system was employed in order to avoid double counting, thus, counting is done in one direction. The switches are connected in such a way that a pulse is sent only when they are triggered in one direction, this results to the introduction of a transistor for its switching ability. The output of the transistor is connected to the display driver, which in turn is connected to the seven segment display. The circuit counts a maximum of 999 after which it resets to zero. The real implementation of the devise is done on this work.

Keywords: Decade Counter, Timing Circuit, Bus Passenger, Seven Segment Display, Electronic Circuit Design

1. Introduction

The rapid development of today's technology is as a result of the enormous expansion in the field of electronics and the future has no apparent restrictions over it. In keeping with this technological advancement, electronics has grown out uniquely to make human endeavor in many facets of life more meaningful.

Digital devices operated automated are very important such that, they are useful in providing accuracy as well as saving human beings from constant monitoring of a given process of a system. Hence electronic indicators are useful without which, life of today's man would encounter a serious setback, though it is said, the human brain was the first processor and still reigns supreme, later version of synthetic processors only aid, and presumably at a faster rate, but still very much dependant on the brain.

Generally, electronics have come a long way over the past century to add to the development of man. In virtually every area of human endeavor electronics have found its place; reducing tedious work practices, saving working time, increasing efficiency with productivity and accomplishing jobs, that would otherwise have taken a life time to completely execute.

In accounting for instance, computation and record keeping can be done using computer and ordinary calculator. Furthermore, records of actual figures can also be taken at a particular time and stored for referencing and record keeping. In most developing countries, electronics is fast finding its way into every home, office, even within the transport system employed by various individuals and corporate bodies. For example, the number of passengers that use a bus and the number of vehicles going into a parking lot within a period of time can be easily known with the use of electronic counter.

In this work, the actual number of passengers that use a commercial transport scheme and or a parking lot over a specified period of time is gotten. This can aid its accounting department in getting the actual figure

to serve as a reference for the income generated over a set period, and the management of a parking lot to know the maximum number of vehicles a parking lot can take. The Federal University of Technology Minna bus transport scheme for instance, employs the use of tickets sales, through which money is remitted to the school. Most passengers prefer to pay cash for the bus service whenever needed. In this way funds go unaccounted for, hence the reduction in the actual income to be generated. In order to solve this problem this research comes to be. The electronic circuit primarily counts the number of passengers that use the bus, which compels personnel's response to revenue collection to balance income with the number of passengers that used the bus. By this, even the normal collection of money by the driver assistance can be employed.

For clarity and neatness of presentation, the article is outline in to five (5) sections. The First Section gives a general introduction of low cost digital bus passengers counter. Work related to the topic of the research is presented in Section Two. In Section Three, we outline the design and implementation procedures. Section Four presents the experimental results. In Section Five, we conclude the work with some recommendations. Finally, the references are presented at the end of the paper.

2. Related Work

This section provides the theory behind the design of our low cost digital bus passenger counter along side with some work related to this our work. It will also be notice in this section that several effort have been made in the design of counting systems for different purpose, but the cost, durability and effectiveness needs to be considered.

2.1 Related Work

One would not truly appreciate the electronic means of counting that is all around us today, if there is no knowledge of how counting evolved. Man actually was the first counting machine that existed, from his basic small counting he discovered that the number of thing i.e. needed to number increased. This is why he needed help. The first counting equipment made is believed to be the Abacus. The Abacus is an ingenious counting device used on the relative positions of two sets of beads moving on parallel strings, the first set contains five beads on each string and allows counting from 1 to 5, while the second set has only two beads per string representing the numbers 5 and 10. The Abacus system seems to be based on a radix of five. Using a radix of five makes sense since humans started counting objects on their fingers

Presently, not much has been done using a normal electronic counter in the area of passengers monitoring and information collection. But in several ways basic electronic counters are used (Giogio-hill, 2000; Hollerith, 2012; Jones, 2012). An automation room light here once a person enters the room and the circuit registers a count (increments) it enables the light while if that same person leave, meaning there is no person in the room, the counters data is decreased by one and causes the light to switch off (Jobs, 2010). In most cases one switch is used because there is an entry separate from the exit door or the number of persons within a location at anytime is desired, therefore an up/down counter is used. But if restricted to one door for entry and exit some modification-has to be done. Like in this case two switches were used in place of one .both connected through different pins of a switch which decide whether the counter should count or not. In this way it is needless to count every person at the time of entry and exit then divide by two to get the number of passengers.

The advantages of this circuit above existing ones (if any) is that, it is designed with full knowledge of the prevalent factors affecting the bus (People moving in and out of the bus while bus is idle and waiting for full load). Possibility of double counting is reduced to very near zero.

2.2 Theoretical Background

In this subsection, we shall discuss the theory related to our work and the major components that we shall use during the design process.

Generally speaking, the research centers on how passengers are counted as they make use of the buses themselves. To achieve this, component ranging from simple resistors to small scale integrated circuits, neatly arranged to give a count for each passenger. For a good understanding of the circuit to be discussed in the next section, there is need to know the theory behind the various component used to achieve it.

2.2.1 Counters

Almost any complex digital system contains several counters. A counter's job is the obvious one of counting events or period of times or putting events into sequence. Counters also do some not so obvious jobs like dividing frequency, addressing and serving as memory units. Counters are basically of two types (Hughes, 1995; Hurowitz et al., 1995, 1998) which we shall look at one after another. Firstly, ripple counters. These counters are the simplest type of binary counters, since they require the lowest components to produce a given counting operation. They do, however, have one major drawback, which is caused by their basic principle of operation; each FF is triggered by the transition of the preceding FF because of the inherent propagation delay time (T_{pd}) of each FF; this means that the second FF will not respond until a time T_{pd} after the first FF receives an active clock transition (that is a complete cycle, two pulses), the third will not respond until a time $2 * T_{pd}$ after a clock transition and so on. In other words, the propagation time of the FF accumulates so the FF will not respond until a time $2 * T_{pd}$ after the clock transition occurs. The above operation can be seen through the truth table.

2.2.2 Transistors

Transistors are active components used basically as amplifiers and switches. The two main types of transistors are; the bipolar transistors whose operations depends on the flow of both minority and majority carriers and the unipolar of field effect transistors (called FETs) in which current is due to majority carriers only (either electrons or holes). The transistor as a switch operates in a class 'A' mode. In this mode of bias the circuit is designed such that current flows without any signal present. The value of bias current either increased or decreased about its mean value by input signals (if operated as an amplifier), or ON and OFF by the input signal if operated as a switch Figure 1 shows the transistor as a switch.

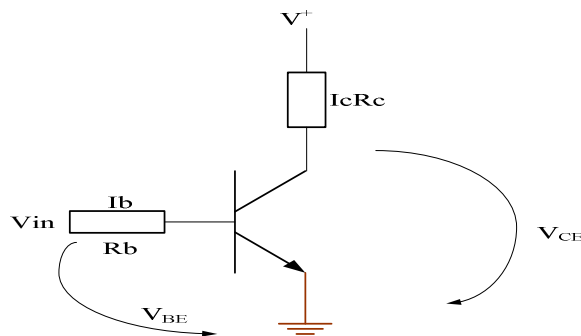

Figure 1. Transistor as a switch

For the transistor configuration, since the transistor is biased to saturation

$V_{CE} = 0$, when the transistor is ON,

This implies that,

$$V_+ = I_c R_c + V_{CE} \quad (1)$$

$$V_{in} = I_b R_b + V_{BE} \quad (2)$$

$$\frac{I_c}{I_b} = h_{fe} \quad (3)$$

$$R_b = \frac{V_{in} - V_{BE}}{I_b} \quad (4)$$

Where

I_c = collector current, I_b = base current, V_{in} = input voltage, V_+ = Supply voltage, V_{CE} = collector emitter voltage, H_{fe} = current gain, and V_{BE} = Base emitter voltage.

3. System Design and Analysis

In this section, the design of the various units of the system build up and the theory of operations of the entire system are considered. The design is also based on the availability and cost implication of components to be used for the realization of this research. This section will discuss the design procedure and how it was implemented. The realization of the main objectives of counting the numbers of passengers received in business over a period of time by the Federal University of Technology bus scheme is illustrated below.

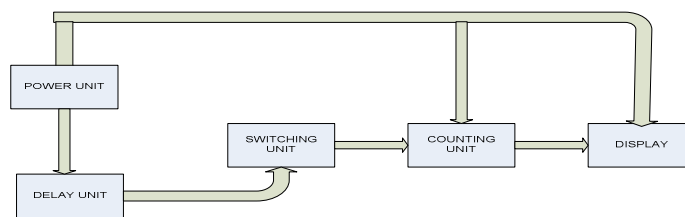

Figure 2. Modular representation of the bus passenger/vehicle counter

The modules (units) will be explained in details in the coming subsection, after which the actual circuit diagram will be looked at. Designing of a prototype for an in house demonstration has some constrains. This will induce some modification of the circuit from the actual operation of the circuit in the bus. The modular description is explained thus.

3.1 Power Unit

This unit consists of the following; car battery, a voltage regulator, and a power delay circuit. A normal bus battery is 24V with current rating of 110 to 200 amperes. This is far much more than is needed for a simple electronic circuit, therefore, the need to reduce the incoming power according to the circuit requirement. The battery is connected to voltage regulator as shown in Figure 3 below.

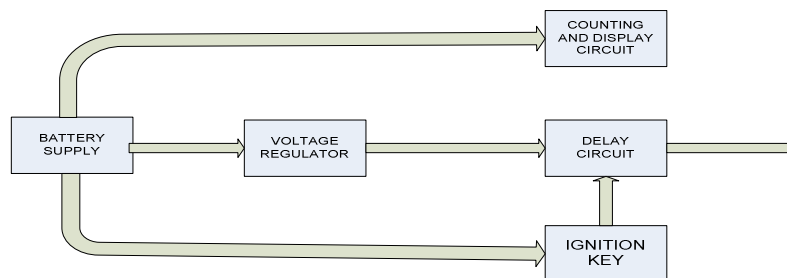

Figure 3. Practical Application of Power Unit in the Bus

The voltage regulator reduces the voltage to 5V and keeps it constant at that point, dissipating the excess power as heat (Reason for the reduction of voltage to 5V was a result of inability to get a CMOS driver for the display unit restricting the circuit to TTL), from this point supply is connected to two different points. The first is to the counting and displaying unit. This is to ensure that the data stored in the counter is not lost when the parts of the circuit is turned OFF. While the other goes to a delay circuit that has its trigger as the ignition key, the output thereof is connected to the main circuit,

Another means of realizing this power unit (particularly for in-house presentation) requires little modifications.

A transformer is used to step-down the supply mains of 240, 50Hz to 12V, 50Hz supply. (The transformer employed is a 240/12V 1000mA),

The 12V AC supply is then passed through a rectifier circuit which normally comes in the form of a single chip of 4 pins. The rectifier converts the AC to DC of equivalent voltage (except for the 0.6V reduction due to the forward voltage drop of a diode.) This now is connected to a filter circuit, in this case is in parallel with the resistive load (main circuit). The type of filter employed is a series-connections filter which uses a large capacitor in parallel with the resistive load. All stages in the project uses 12V d.c, the power supply stage is a linear power supply type and involves a step-down transformer, a filter capacitor, and voltage regulator. To calculate the approximate value of the capacitor that will give a ripple factor of less or equal to the desired value.

$$C = \frac{I \times dt}{\Delta V} \quad (5)$$

Where I_{ve} = the total current to the resistive load

$$F = \text{Frequency} = \frac{1}{T}$$

Y = ripple factor

V = Circuit operating voltage.

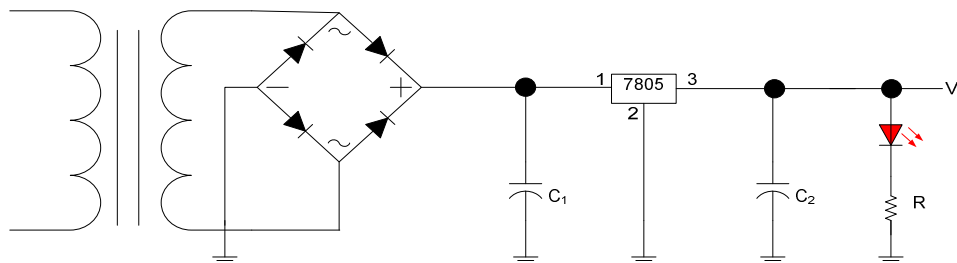

Figure 4. Power supply stage

For this circuit, we would require a 7805 voltage regulator as shown in the figure above which gives a required output of +5V. The voltage regulator regulates above its required output voltage, if the voltage is below, its required output voltage would be passed out without been regulated. For example for a 7805, if the unregulated input voltage is greater than 5V, it will be regulated to 5V, but if it's less than 5V, for example 3V, the 3V unregulated will be outputted.

3.1.1 Design Analysis

If the unregulated input of the 7805 is greater than the required output by a factor of 4, that is $5+4=9$, the voltage regulator IC, starts getting hot and will be damaged. Hence we will need an input into the 7805 to be approximately 9V.

Since, the diode drops 0.6V and we have 4 rectifying diodes forming the full wave bridge, the voltage drop

will then be $0.6 \times 4 = 2.4V$

For a peak voltage of $9+2.4=11.4V$ peak.

$$\text{For the r.m.s voltage} = \frac{18.4}{\sqrt{2}} = \frac{18.4}{1.4} = 13.143V$$

Hence a transformer of a preferred value of 15V was employed. i.e 220V/15V transformer

Assuming a ripple voltage of 15%

$$dv = \frac{15}{100} \times 18.4V = 2.76$$

$$dt = \frac{1}{2f} = \frac{1}{100} = 0.01$$

$$C_1 = \frac{1 \times 0.01}{2.76} = 3.623 \times 10^{-3}F$$

$$C_1 = 3300\mu F$$

A preferred value of 3300 μF was however employed. To reduce the ripple left, a compensating capacitor C_2 was used and a 4065 μF was employed.

3.2 Delay Unit

The delay unit comprises of the following, a push button (normally closed) switch, a 555 timer and combinational simple circuit of a capacitor-resistor as shown in Figure 5.

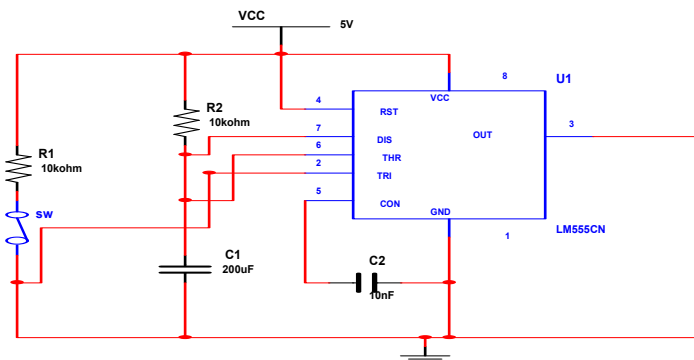

Figure 5. The delay circuit

The diode is placed in between the 555 timer and the capacitor for two reasons; to act as a protective device for 555 timers, and to force the capacitor to discharge in one direction, offering very high resistance in the other direction.

3.3 Switching Unit

This unit is the centre of this whole circuit, which I call the decision section. *Here* it is expected to differentiate between a pulse that should be counted and those that should not. Looking at the characteristic

of an AND gate that is high (1) when the two inputs are high (1) that can be seen in Table 1.

Table 1. Truth Table of an AND gate

A	B	OUTPUT
0	0	0
0	1	0
1	0	0
1	1	1

By varying the time of each pulse reaching the AND gate, one can discriminate between the input A and B being high or alternating. This variation was achieved through the use of a transistor. Here the transistor acts as a switch. Working in a common emitter mode with input current (base current) coming from the delay circuit and a shape pulse coming from a push button switch connected to the collector terminal. It could be seen in Figure 6 that, the duration of the pulse that comes from the switch S is much shorter than that which comes from the input of the base terminal. In this way once the 200uF capacitor is charged it begins to discharge gradually through the transistor to the ground. But if during that discharge a pulse comes from the collector, only then will an output be seen at V_{out} . This is to say if the switch S is pushed first; the pulse comes into the collector and goes to the ground because there is no base current to complete the switching process. Whereas if the switch in the 555 timer is triggered first then it charges the delay circuit that will hold enough charge to complete the switch at the arrival of the collector current.

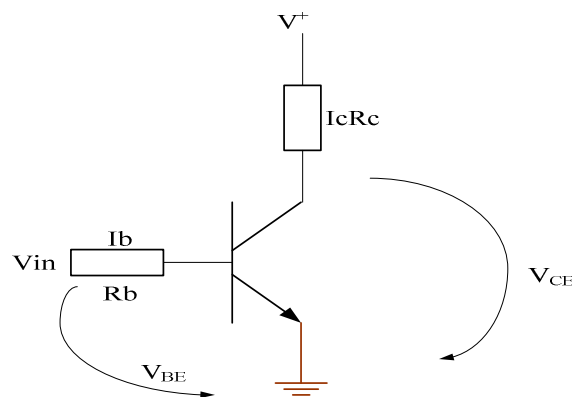

Figure 6. A Transistor Switch

The resistor $R_2 = 330$ ohms acts as a pull down resistor dropping the internal voltage of the counter to less than 0.8 from its original value of 1.6V,

3. 3 Counting Unit

It is expected to keep track of event, in this case every pulse that comes out of V_{out} of the transistor. To achieve this, three counters were employed; primarily to give a *three* digit count (up to 999). the basic blocks of the counting unit involves, the 74LS90 decade counter, 74LS47 BCD-to-seven-segment decoder/driver, and Light emitting diode (LED) display of the common anode type.

The 74LS90 is a high speed, monolithic decade counter consisting of four dual-rank Master-slave flip-flops internally interconnected to provide a divide-by-two counter and a divide by five counters. The 74LS90

circuit is negative edge triggered. From the pin layout below, it can be seen that the device has two clock inputs Ai and Bi and output are QA, QB, QC, and QD. The 7490 counter has four reset leads, Ro (1), Ro (2), R9 (1) and R9 (2). When the Ro leads are logic 1 together the counter output resets to decimal 0 or QDQCQBQA = 0000. On the other hand, making the R9 leads logic 1 causes the output to reset to decimal 9 or QDQCQBQA= 1001. Those leads can be used to change the count sequence.

The 74LS47 integrated circuit is a standard decoder/driver. Its outputs are buffered to a voltage rating of 15V and current of 20mA to enable it drive a LED display directly. From the pin layout, it can be seen that the decoder has four inputs A, B, C, and D where D is the most significant bit. There are seven output leads marked a through g. It has three control leads, RB₁ is ripple-blanking input, and RB₀ is for ripple blanking output and LT Lamp test. The 74LS47 is designed to drive the common anode LED when using it to drive the common cathode LED, the outputs are inverted.

The display uses an array of seven light-emitting diodes to form numbers in the range from 0 to 9 and another diode to provide the decimal point. To operate the common anode LED display, all anode terminals must be supplied by a positive voltage of 5V, for a number to light; the correct cathode lead must be connected to ground. Usually, a resistor should be connected in series with each segment to limit the current in the respective diode segment. Below is the connection of the complete counting unit.

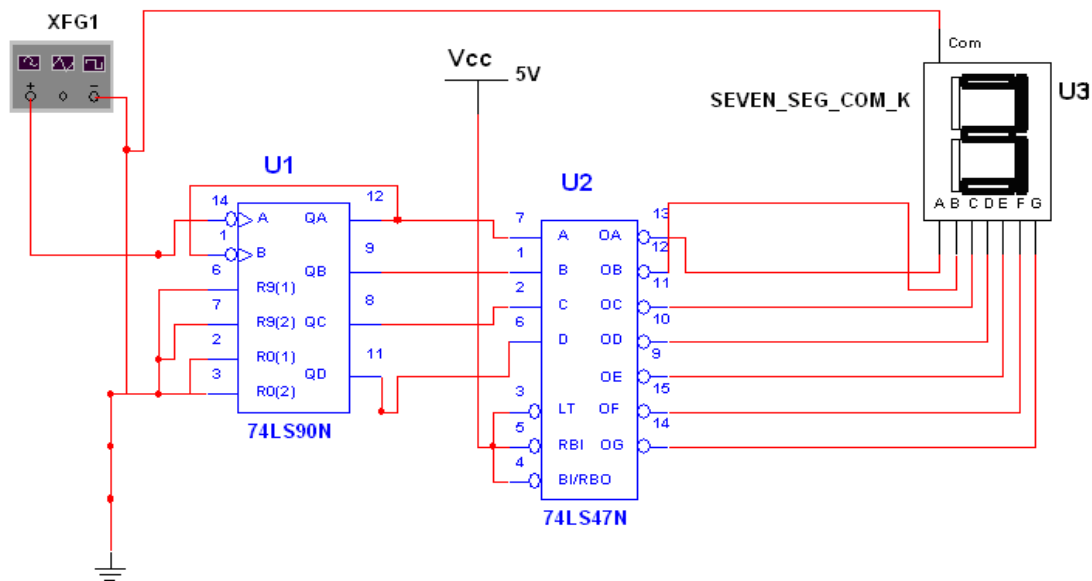

Figure 7. Pin connections of the complete counting unit

3. 3.1 Design Calculation of the Counting Unit

Across the 555 timer,

Total external resistance = 10k + 10k = 20k

Voltage across the resistor = 5V

Therefore, current flow to the 555 timer, $I_1 = V / R$

$I_1 = 5 / 20k = 0.25m A$.

The current drop across the pull down resistor of 330 ohm, for a voltage drop of 1.6V,

$$I_2 = 1.6/330 = 4.848\text{mA}$$

The current drop across one of the resistor connecting the output of the decoder to the anode of seven segment display receiving a voltage drop of 5V is

$$I_3 = 5/330 = 0.015\text{ A.}$$

Since there are seven connected in such a manner for each of the two decoder (meaning R x 14).

$$I_{3T} = I_3 \times 14 = 0.015 \times 14 = 0.212\text{A, and } I_{3T} = 212\text{mA.}$$

Being that the TTL, 1C family requires low milliwatts to operate. Current through the 1C is negligible.

Hence, total current within the circuit I_T will be given as:

$$I_T = 212\text{mA} + 4.845\text{mA} + 0.25\text{mA} = 217.095\text{mA.}$$

With the knowledge of the expected circuit current consumption, the filter capacitor to be used is calculated using the formula given below:

$$C = \frac{I_{DC}}{4\sqrt{fV_{IF}}} \quad (6)$$

$$= 241.8\text{mA} / (4\sqrt{3 \times 50 \times 5 \times 0.07}) = 1.994 \times 10^{-3}$$

For which 220uF was chosen

Recap:

1. The choice of 10k resistor between Pin 7 and source for the 555 alongside the

98.7×10^{-3} F was to achieve a delay of one second in the conducting part:

$$T = 1.1 \times 10\text{k} \times 98.7 \times 10^{-3} = 1.0857\text{ sec.}$$

2. The delay made by the resistor-capacitor circuit will offer a delay of $T = R \times C$. where, $R = 20\text{kohms}$ and $C = 1 \times 10^{-4}$ F

Therefore, $T = 20\text{k} \times 10^{-4} = 2\text{ seconds.}$

4. Experimental Results and Discussions

In this section, we itemized the steps and stages of procedure taken to verify the mathematical calculated results through the real time experimental results.

4.1 Testing

The physical realization of the project is very vital. This is where the fantasy of the whole idea meets reality. The designer will see his or her work not just on paper but also as a finished hardware. After carrying out all the paper design and analysis, the project was implemented and tested to ensure its working ability, and was finally constructed to meet desired specifications. The process of testing and implementation involved the use of some measuring equipments.

Table 2. Components Test results

Component	Test	Result	Remark
555 timer 1C	Multimeter (V)	4.22	Good
Diode	Multimeter (V)	3.55	Good
Counter	Multimeter (V)	1.7	Good

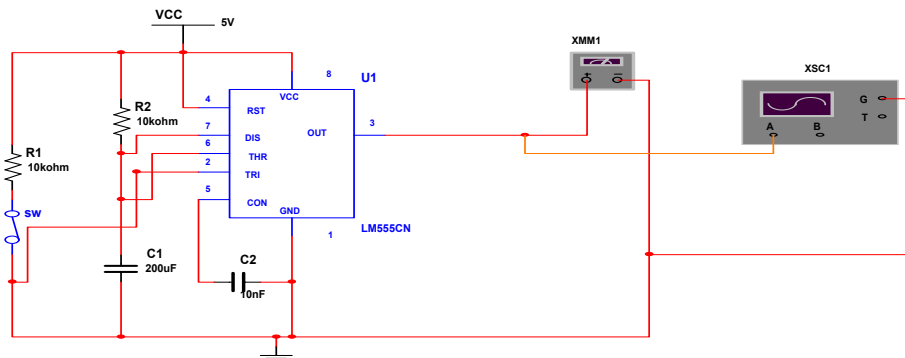

Figure 8. Simulation of the timer circuit

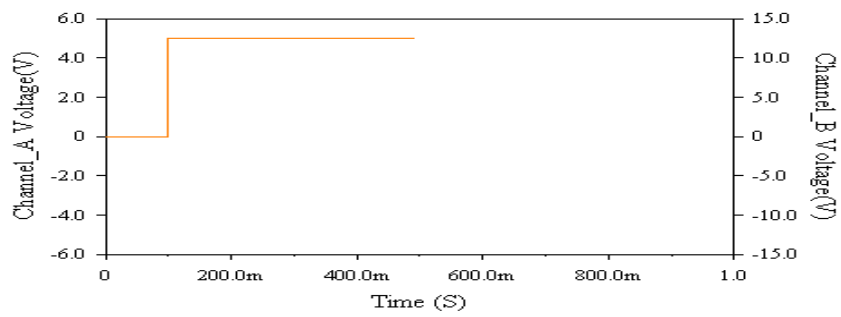

Figure 9. Graph of the one shot timer circuit

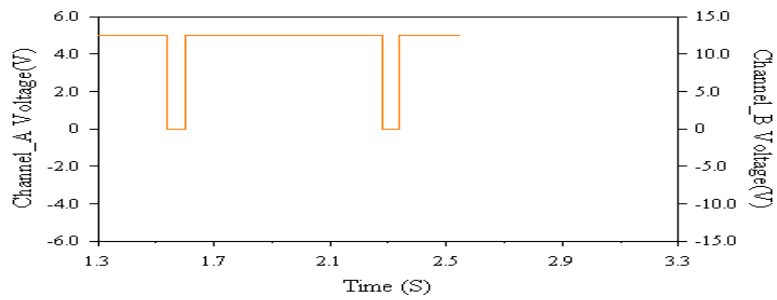

Figure 10. Graph showing the one second (1s) triggers pulse

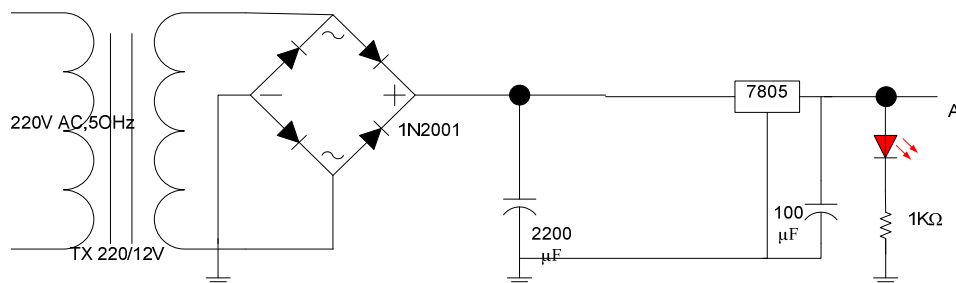

Figure 11. A complete power supply unit

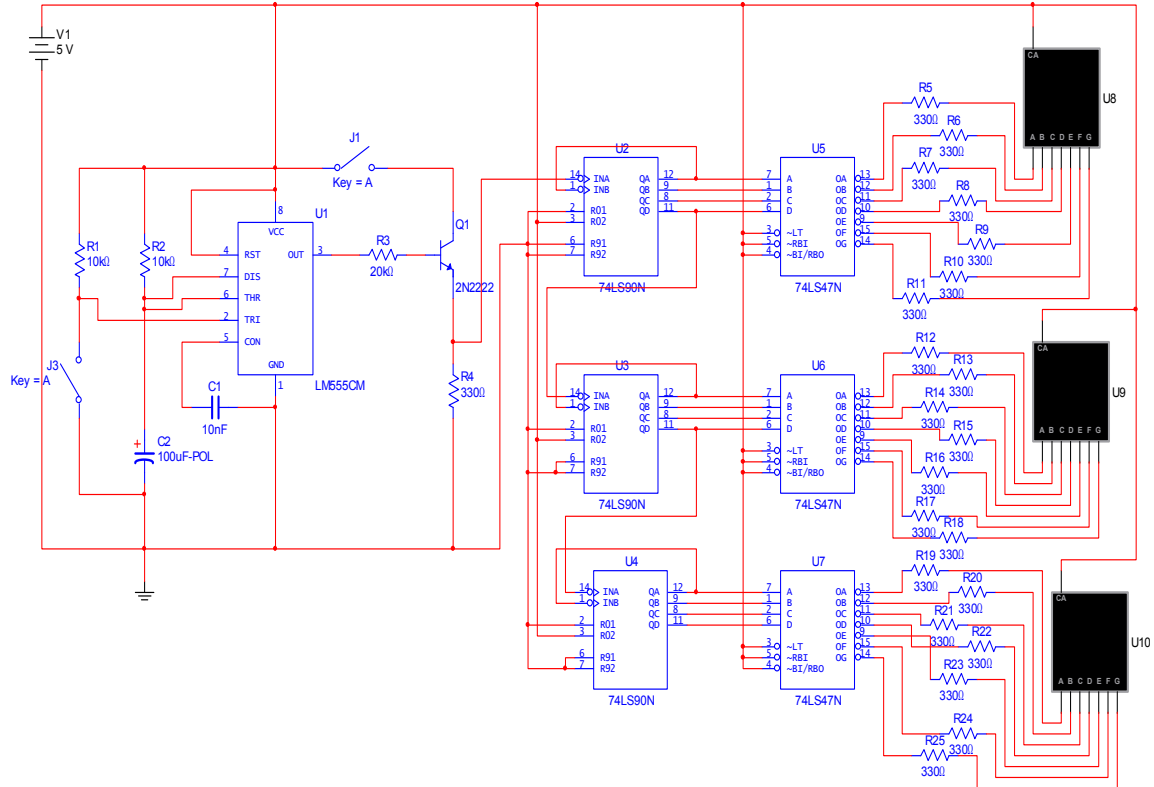

Figure 12. A complete circuit diagram of the digital bus passenger system

4.1 Packaging

For the purpose of a small in-house presentation, a wooden frame was chosen. An illustration of the physical appearance of the prototype is shown in Figure 13.

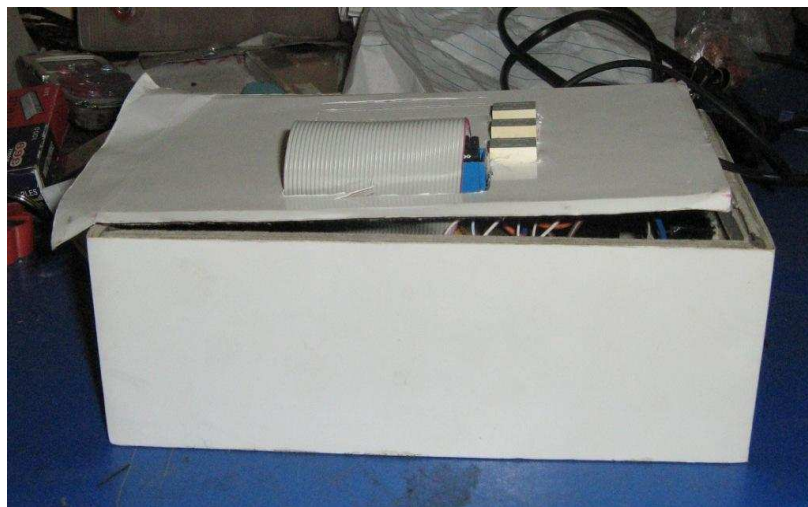

Figure 13. Physical appearance of the prototype

The packaging is made up of eight exterior parts, which are indicated by the thick lines and dimensions. The flat plywood is used for the external coating, and is held firmly to a structure of wood connected along the edge perpendicular to the horizontal ground. Air vents are provided for ventilation, to avoid over-heating due to extreme temperature prevalent in this period of the year.

The display on the other hand was put at the right side of the prototype; mainly to ease presentation and to avoid exposed wires connecting the display to the firmly fixed display drivers mounted on the Vero board.

5. Conclusion

This research was aimed at design and implementation of a low cost digital bus passenger counter system. The results obtained are presented and fully discussed. After carrying out the necessary test, it was observed that the aim of the work was achieved. Initially, the idea that counting the number of passengers that enter the bus can only be achieved with complex circuit due to all its constraints have been proven wrong. The fact that there is only one door for entry and exit of the bus, passengers at times behave radically (entering only to leave the next minute), and cannot be properly counted have also been proven wrong. It is possible to achieve an accurate count of all the passengers that enter the school bus, and thereby, provide data upon which proper accounting can be effected. Given the constraint upon which this work was carried out, some additional features can be included to give better and more precise count. In the switching unit, a delay can be connected to the ignition to start the switch some minutes after the bus starts moving, a delay to be connected also to the ignition to stop the flow of energy to the switch and switching unit, the addition of a de-bouncer to avoid any form of skipping is also necessary, of which is our next point of target. Finally, I will recommend the use of this device only when workers are properly remunerated at when due, and a proper reward system is put in place for the benefit of all stakeholders.

References

- Darkwarriorblake, (Accessed 2012), "Transformers", www.transformer-wikipedia.thefreencyclopedia.htm
- Electronic Circuits (2011), Projects, Electronics design, Circuit Diagrams, Electronics Hobby Kits and Schematics, online available at: <http://www.electronic-circuits-diagram>.
- Giorgio-Hill, (2000), "Principle of Electrical Engineering", McGraw-Hill higher Education, Ohio, 360-392
- Hollerith, H. (Accessed 2012), "An electric tabulating system", Online Available at: <http://www.columbia.edu/acis/history/hh/index.html/>
- Hughes, E. (1995), "Electrical Technology", Addison Wesley Longman Limited, England, 198-206.
- Hurowitz, P. Hill, W. (1988), "The art of Electronics", Cambridge University press, New York, 342-349
- Hurowitz, P. Hill, W. (1995), "The art of Electronics", The Press syndicate of the University of Cambridge, Australia, 269-277.
- Integrated circuits (Chips), (Accessed 2012), online available at: www.kpe.freeuk.com/components/ie.htm
- Jobs S. (Accessed 2010), <http://www.computerhistory.org/sitemap.html>.
- Jones, O.R. (Accessed 2012), <http://www.es.wowa.edu/jones/roling/>
- Ronald, J. Tocci, Widmer, N. Moss, G. (1998), "Digital Systems Principles and Application", Prentice-Hall International Inc., New Jersey, 182-341.
- Theraja, B. L. Theraja, A.K. (1999), "The Textbook of Electrical Technology", S. Chand and Company Ltd, New Delhi, 919- 1953
- Tokeim, (2004), "Digital Electronics, Principles and Applications", sixth Edition, McGraw-Hill Publishing company Limited, New-Delhi, 378-504.
- Tony V.R. (Accessed, 2012), "555 Timer tutorials", available online at: www.555timer-oscillatortutorial.htm